

**ORDINANCE 2023-17**

**AN ORDINANCE OF THE SOUTH WEBER CITY COUNCIL ADOPTING TITLE 2 CHAPTER 3 IMPACT FEES, AMENDING MULTIPLE SECTIONS OF TITLE 10, REPLACING TITLE 11, AND AMENDING DEVELOPMENT, DESIGN, AND CONSTRUCTION STANDARDS**

**WHEREAS**, the South Weber City Council wishes to make changes to the subdivision ordinance pursuant to state law; and

**WHEREAS**, the South Weber City Council desires to facilitate consistent development review processes; and

**WHEREAS**, the replacement of Title 11 to reflect changes to state code necessitates other code changes; and

**WHEREAS**, a public hearing was held before the Planning Commission on the 12<sup>th</sup> day of October, 2023; and

**WHEREAS**, after careful review the Planning Commission unanimously recommended approval of these zoning and subdivision amendments; and

**WHEREAS**, the City Council after considering the information available along with the recommendation finds the amendments satisfactory;

**NOW, THEREFORE, BE IT ORDAINED** by the City Council of South Weber City, State of Utah:

**Section 1. Adoption:** Title 2 Chapter 3 Impact Fees of South Weber City Code is hereby adopted as attached in **Exhibit 1**.

**Section 2. Amendment.** Title 10 Chapter 2 Section 7 Adoption and Amendments shall be amended as follows:

A. **Adoption:** The planning commission shall provide notice and hold a public hearing on a proposed land use ordinance or zoning map and prepare and recommend to the city council a proposed land use ordinance and zoning map that represents the planning commission's recommendation for regulating the use and development of land within all or any part or area of South Weber City. The city council may adopt or reject the proposed land use ordinance or zoning map either as proposed by the planning commission or after making any revision that the city council considers appropriate.

B. **Amendments:** The City Council may, from time to time, amend the number, shape, boundaries or areas of any zone, or any regulation of or within such zones or any other provisions of this title, but such amendments shall not be made or become effective unless the same shall have been proposed by or be first submitted to the Planning Commission for its recommendation. The City Council may adopt or reject the proposed land use ordinance or zoning map either as

proposed by the Planning Commission or after making any revision that the City Council considers appropriate.

**Section 3. Amendment.** Title 10 Chapter 14 Section 5 Sensitive Lands Submittal and Approval Process For Building Permits and Site Plans shall be amended as attached in **Exhibit 2.**

**Section 4. Replacement.** Title 11 shall be replaced in its entirety and will now be read as attached in **Exhibit 3.**

**Section 5. Amendment.** Development, Design, and Construction Standards for South Weber City shall be amended as shown in **Exhibit 4.**

**Section 6. General Repealer.** Ordinances in conflict with this ordinance are hereby repealed to the extent of such conflict.

**Section 7. Effective Date.** This ordinance shall take effect on the 1st day of January, 2024, following its approval and subsequent notification in accordance with legal requirements. Applications duly received before this date shall be processed in conformity with the procedural standards and regulations applicable at the time of their complete submission.

**PASSED AND ADOPTED** by the City Council of South Weber, Davis County, on the 28<sup>th</sup> day of November, 2023.

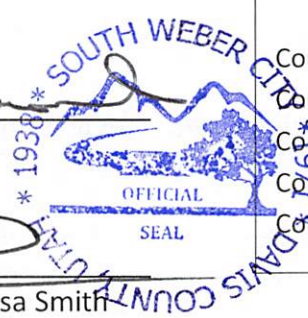
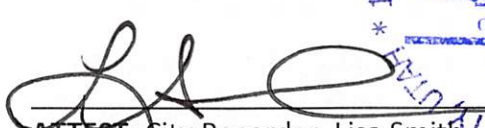
 <b>MAYOR: Rod Westbroek</b>		Roll call vote is as follows:		
		Council Member Halverson	<input checked="" type="radio"/> FOR	<input type="radio"/> AGAINST
		Council Member Alberts	<input checked="" type="radio"/> FOR	<input type="radio"/> AGAINST
		Council Member Petty	<input checked="" type="radio"/> FOR	<input type="radio"/> AGAINST
		Council Member Dills	<input checked="" type="radio"/> FOR	<input type="radio"/> AGAINST
	Council Member Soderquist	<input checked="" type="radio"/> FOR	<input type="radio"/> AGAINST	
 <b>ATTEST: City Recorder, Lisa Smith</b>				

**CERTIFICATE OF POSTING**

I hereby certify that Ordinance 2023-17 was passed and adopted the 28th day of November, 2023 and that complete copies of the ordinance were posted in the following locations within the City this 29th day of November, 2023:

1. South Weber Elementary, 1285 E. Lester Drive
2. South Weber Family Activity Center, 1181 E. Lester Drive
3. South Weber City Building, 1600 E. South Weber Drive

  
 \_\_\_\_\_  
**Lisa Smith, City Recorder**

# **EXHIBIT 1**

## **TITLE 2 CHAPTER 3 - IMPACT FEES**

**CHAPTER 3  
IMPACT FEES**

**2-3-1: FINDINGS AND PURPOSE:**

The City Council hereby finds and determines:

- A. There is a need for public facilities for new developments which have not been constructed and are required to be consistent with the City's general plan and to protect the public's health, safety, and welfare.
- B. The rapid and continuing growth of South Weber City necessitates the imposition and collection of impact fees pursuant to law that require development to pay its fair share of the cost of providing public facilities occasioned by the demands and needs of the development project at service levels necessary to promote and preserve the public health, safety, and welfare.
- C. The impact fees established by this chapter are based upon the costs which are generated through the need for new facilities and other capital acquisition costs required, incrementally, by new development within the City.
- D. The impact fees established by this chapter do not exceed the reasonable cost of providing public facilities occasioned by development projects within the City.

**2-3-2: IMPACT FEES LEVIED:**

- A. Impact fees are hereby imposed as a condition of the issuance of a building permit by the City for any development activity which creates additional demand and need for public facilities in the following City systems: culinary water, sewer, storm drainage, transportation, parks, recreation, and public safety fire station
- B. The City shall also collect the Central Weber Sewer District and Weber Basin Water Conservancy District's treated water impact fee for developments creating additional demand on that system and remit the same to each respective district.
- C. Impact fees are hereby levied for the City service area for the systems identified in this section as set forth in the City's consolidated fee schedule.
- D. All impact fees shall be paid prior to the City issuing a building permit.

**2-3-3: SERVICE AREA:**

The entire area of the City and any areas outside of the City served by such systems are designated and established as one service area with respect to the City's culinary water, sewer, storm drainage, transportation, parks, recreation, and public safety fire station systems, including the Central Weber Sewer District and Weber Basin Water Conservancy District's Treated Water System.

**2-3-4: ADJUSTMENT OF IMPACT FEE:**

- A. The City may adjust the impact fees imposed pursuant to this chapter as necessary in order to:
  - 1. Respond to unusual circumstances in specific cases;
  - 2. Ensure that the impact fees are imposed fairly;
  - 3. Permit the adjustment of the amount of the fee based upon studies and data submitted by an applicant as approved by the City Council in order to ensure that the fee represents the proportionate



share of the costs of providing such facilities which are reasonably related to and necessary in order to provide the services in question to anticipated future growth and development activities; and

4. Allow credits against impact fees for dedication of land for improvement to or new construction of any system improvements as defined by the Utah Impact Fees Act.

B. The City Manager shall have the authority to make such adjustments based upon information submitted by an applicant and any recommendations from the City Engineer.

C. The City Manager may adopt policies consistent with this chapter and any resolutions passed by the City Council to assist in the implementation, administration, and interpretation of this chapter.

D. If the applicant, person or entity is not satisfied with the decision of the City Manager, an appeal may be made to the City Council under the procedures set forth in section [2-3-5](#) of this chapter.

E. Each applicant shall be entitled to a credit or refund, if applicable, for any impact fees previously paid for the same building permit or development activity.

**2-3-5: ADMINISTRATIVE CHALLENGES AND APPEALS PROCEDURE:**

Any person or entity required to pay an impact fee who believes the fee does not meet the requirements of law may file a written request for information with the City as provided by the Utah Impact Fees Act and any other relevant information relating to the impact fee.

A. Any person or entity residing in or owning property within the City who believes the fee does not meet the requirements of the law or wishes to challenge the fee shall file a written appeal within thirty (30) calendar days after payment of any impact fee with the City Recorder setting forth in detail all factual and legal grounds in support of the appeal. Upon receipt of the appeal, the City Manager shall make a recommendation to the City Council and schedule a public hearing before the City Council on the appeal for the purpose of receiving input from all interested persons. The City Council shall thereafter render its decision on the appeal no later than thirty (30) days after the date the appeal was filed.

B. Any person or entity who has failed to comply with these administrative remedies may not file or join an action challenging the validity of any impact fee.

C. Any person or entity who was a party to an appeal under this section who is adversely affected by the decision of the City Council may petition the District Court for a review of the decision within ninety (90) days of a decision upholding an impact fee by the City Council or within one hundred twenty (120) days after the date the challenge to the impact fee was filed, whichever is earlier. Such a declaratory judgment action or petition for review challenging the validity of the fee shall be filed in the District Court for Davis County.

D. In the event a petition is filed with the court, the City shall transmit to the reviewing court the record of its proceedings, including the minutes, findings, orders and, if available, a true and correct transcript of its proceedings.

E. If the proceeding was audio recorded, a transcript of that audio recording is a true and correct transcript for the purposes of subsection D of this section.

F. If there is a record:

1. The District Court review is limited to the record provided by the City; and

2. The court may not accept or consider any evidence outside the City record unless that evidence was offered to the City and the court determines that it was improperly excluded by the City.

G. If there is an inadequate record, the court may call witnesses and take evidence.

H. The court shall affirm the decision of the City if the decision was supported by substantial evidence in the record.

I. The Judge may award reasonable attorney fees and costs to the prevailing party in any action brought under this section.

**2-3-6: ACCOUNTING, EXPENDITURE AND REFUND OF IMPACT FEES:**

The impact fees collected pursuant to this chapter shall be deposited into a separate interest-bearing ledger account and may only be used for capital improvements for which the fees were collected. The accounting, expenditure, and refund of all such impact fees collected shall be handled in accordance with the provisions of the Utah Impact Fees Act.

## **EXHIBIT 2**

# **TITLE 10 CHAPTER 14 SECTION 5 SENSITIVE LANDS SUBMITTAL AND APPROVAL PROCESS FOR BUILDING PERMITS AND SITE PLANS**

**10-14-5: SENSITIVE LANDS SUBMITTAL AND APPROVAL PROCESS FOR BUILDING PERMITS AND SITE PLANS:**

Each step should be followed in the order outlined.

A. A meeting may be requested to determine the feasibility of the development and review the sensitive lands overlay map from the general plan to determine if the site is in the sensitive lands area and if it is, what hazards are associated with the site. If the site is outside of the sensitive lands area, the process outlined in title 11, "Subdivision Regulations", of this code will be followed. If it is subsequently determined that the site is within the sensitive lands area or the site has geologic hazards that are not shown on the map the review process will be pursuant to this chapter.

B. All building permits on single lots, which are in the sensitive lands' areas, will follow the outline through this section up to subsection D of this section after which the building permit may be issued administratively after it is determined that the lot can be developed in accordance with the intent of this chapter.

If the only hazard associated with the site is high liquefaction, then the applicant must submit a soils report with recommendations for control of subsurface water as well as footing and foundation design after which the proposal will follow the process outlined in title 11 of this code.

C. All applications required in this section shall first be submitted for review by the City Planner or designee and the City Engineer or designee. The following items are required to be submitted with the application for site plan:

1. Location of the proposal, with identification of abutting streets;
2. A plan showing the average "slope" (as defined in section [10-14-8](#) of this chapter) of the proposed site broken down into homogenous slope zones, generally with no more than a five percent (5%) difference in slope within each slope zone and with each zone no smaller than ten thousand (10,000) square feet;
3. The number of lots;
4. The location and size of proposed lots;
5. Location, width, and grade of all proposed streets or hard surfaced areas, and radius of any cul-de-sac;
6. Soil/geologic report that addresses all items in the scope of work as approved by the committee and, if applicable, recommendations by a qualified geotechnical engineer. Reports shall be site specific and identify all geologic hazards, whether on or off site, if it affects the particular property including the following hazard(s):
  - a. Flood history and potential; proximity to known canals, lakes, streams, and alluvial fan flooding;
  - b. Definition of any zones of deformation with respect to active faults and recommended setbacks therefrom;
  - c. Evidence for other mass movement of soil and rock (landslides, debris flows, rockfalls);
  - d. Evaluation of the site for global and local instabilities;
  - e. Identification of anomalies of the terrain or characteristics of the geological materials which would have any potential impact upon the use of site;

f. Determination of characteristics including any contamination that may be present in the groundwater or soil;

g. The report shall contain written recommendations for construction of structures and avoidance or mitigation of the hazards;

h. Report on soil characteristics. Data regarding the nature, distribution, and strength of soils within the project area. The soil report shall include a unified classification of all soils with an estimate of susceptibility to erosion, plasticity index, liquid limit, shrink-swell potential, and general suitability for development;

i. Estimate of the likely highest level of the water table considering the long-term effects of development and irrigation.

D. After the application is received, the geologic and soil report will be reviewed by the City Planner or designee and the City Engineer or designee and, if geologic hazards exist, other geotechnical advisors which may include the Utah geologic survey (UGS). If after review, the committee concurs with the geologic and soil report submitted by the applicant, the item will be forwarded to the planning commission for review for preliminary plan or site plan approval. If the submitted information does not provide sufficient data for recommendation of approval, the City may require additional studies to be performed.

A determination by the City Planner or designee and the City Engineer or designee that the site plan cannot be developed may be appealed by the applicant to the appeal authority by filing of a written notice of appeal within thirty (30) days of the action.

## **EXHIBIT 3**

# **TITLE 11 SUBDIVISION REGULATIONS**

**TITLE 11**

**SUBDIVISION REGULATIONS**

**11.01 GENERAL PROVISIONS**

**11.01.01 TITLE:** This Title shall be entitled as the **SUBDIVISION ORDINANCE OF SOUTH WEBER CITY, UTAH, and may be so cited.**

**11.01.02 Purpose**

Promote the health, safety, convenience, and general welfare of the inhabitants of the City in the matter of Subdivisions or matters affected by Subdivisions through provisions designed to:

1. To promote the health, safety, convenience, and general welfare of the residents of the City;
2. To ensure the efficient and orderly subdivision and development of land within the City;
3. To prevent the uncontrolled division and development of real property, which may be done without considering the rights and best interests of adjoining property owners and the City as a whole;
4. To avoid subdivisions and developments that:
  - a. Do not comply with the City general plan or ordinances,
  - b. Cannot be adequately served by existing utilities or public services,
  - c. May prove to be dangerous or unsafe due to design, natural or man-made hazards existing prior to or created by the subdivision and development,
  - d. May cause an undue burden on existing traffic or transportation services, or
  - e. May require the future expenditure of public funds to correct problems caused by the subdivision and development;
5. To provide design standards for public improvements, facilities, and utilities to provide for reasonable access to public rights-of-way, parks, trails, or open spaces, to provide for the dedication of land and streets deemed necessary for the proper development of the subdivision, and to provide for easements or rights-of-way that are necessary to service the properties created by the subdivision.

**11.01.03 Scope**

1. This Title is designed to inform the Subdivider and public of the requirements and conditions necessary to obtain approval of a Subdivision. Because each parcel of real property has unique site/situational characteristics (whether natural or man-made), there may be some aspects of subdivision development that cannot easily be articulated. For this reason, it is not possible to cover every possible contingency. Therefore, the Administrative Land Use Authority has the authority to impose reasonable conditions for the subdivision and development in addition to those expressly required, provided that:
  - a. The conditions are not arbitrary or capricious;
  - b. The conditions do not conflict with any local, state, federal law.

2. This Title shall apply to lots or parcels where public rights of way are dedicated, and public improvements and infrastructure are installed regardless of whether the land is subdivided.

#### **11.01.04 Definitions – Process Related**

**Administrative Land Use Authority.** The appointed board, consisting of the City Manager and/or City Planner, Public Works Director, City Engineer, two Council Members as available and appointed by the Mayor, and others as assigned, are responsible for reviewing applications and land use decisions arising from subdivision applications. The Planning Commission shall be the Administrative Land Use Authority for the approval of the Preliminary Plat only. The process is administered and overseen by the City Planner or designee. The City Council shall be the Administrative Land Use Authority for the approval of vacating a street, right of way, or easement only.

**Applicant or Subdivider or Developer.** A person or persons making an application to create a subdivision.

**City:** South Weber City, Utah

**City Engineer:** The city engineer of South Weber City or any individual or firm retained or designated by South Weber City as the city engineer for the purpose of performing engineering duties.

**City Planner:** The director of the Community Development department of South Weber City.

**Complete Application.** A Subdivision Application shall be considered complete as defined in each Application Section.

**County:** Davis County, Utah

**Development, Design, and Construction Standards:** The Public Works Standards referred to in this Title and adopted by Title 9-7-1.

**Geological Hazard.** The restrictions and requirements of the review cycle do not apply to the review of subdivision applications affecting property within identified geological hazard areas (property identified to be within the city's "Sensitive Lands" – see Title 10-14).

**Improvements:** All infrastructure improvements, such as water, sewer, storm drain, land drain, secondary water, curbs, gutters, sidewalk, grading, streetlights, paving, landscaping, fencing, electric power, natural gas, communication lines, and all other elements required by this Title and the Public Works Standards.

**Planning Commission:** The South Weber City Planning Commission.

**Review Cycle.** There shall be no more than four (4) total review cycles. A review cycle shall be considered complete when:

1. Complete Application is submitted to the Administrative Land Use Authority;
2. The Administrative Land Use Authority Review is complete;
3. The Applicant Response to Review is complete; and
4. The Administrative Land Use Authority provides a written statement to the Applicant stating completion of the review cycle and next required steps for approval.

#### **Review Cycle, Exceptions.**

1. Additional Review Cycle(s). May be required when a modification or correction is necessary to protect public health and safety or to enforce state or federal law when a change or correction



is necessitated by the Applicant's adjustment to a plan set or an update to a phase plan that adjusts infrastructure needed for the specific development.

2. Additional Time for Review. If the Applicant does not submit a revised plan within twenty (20) business days after the Administrative Land Use Authority requires a modification or correction, the Administrative Land Use Authority shall have an additional twenty (20) business days to respond.
3. Other Land Use Applications. The Review Cycle as defined in this Title applies only to single family, townhome, and twin-home land use applications. Review times and cycles may vary for multifamily, commercial, industrial, institutional, and other non-residential land use applications.

**Subdivision Improvement Plans.** Civil engineering and design plans associated with required infrastructure and City owned/operated utilities required for a Subdivision.

**Subdivision Ordinance Review.** A review to verify that an application for a Subdivision meets the criteria of the applicable City Ordinance(s). The Administrative Land Use Authority shall notify the Applicant in writing of the deficiency in the application and the right to appeal the determination to a designated Appeal Authority as stated in Title 10-4.

**Subdivision Plan Review.** A review of the Applicant's Subdivision improvement plans and other aspects of the Subdivision application to verify that the application complies with all ordinances and applicable standards and specifications, including the current Public Works Standards for Development, Design, and Construction.

#### **11.01.05      Validity**

If any section, subsection, sentence, clause, or phrase of this Title is, for any reason held to be invalid, such holding shall not affect the validity of the remaining portion of this Title.

### **11.02   ADMINISTRATION**

#### **11.02.01      Final Platting and Recording Required**

1. **Terms.** Any division of real property within the City is subject to the terms of this Title. The division of real property includes the sale, gift, transfer, conveyances, split, or other division that results in changing the boundaries or legal descriptions of a given parcel of real property and results in the creation of a new parcel of real property.
2. **Unlawful Subdivision.** No land which is located wholly or in part in South Weber City may be subdivided, the plat be filed and recorded in the County Recorder's Office, nor lots be sold unless such Subdivision has been created pursuant to and in accordance with the provisions of this ordinance.
  - a. **Exception.** Joining a lot or lots to an existing parcel does not constitute a Subdivision nor does it require a Subdivision plat amendment.
3. **Final Plat Approval.** Lots shall not be transferred or sold, nor shall a building permit be issued for a structure thereon, until the final plan of a Subdivision is approved, and the final plat is recorded in accordance with this Title and the provisions of state law, and until the

improvements and infrastructure required in connection with the Subdivision have been constructed or guaranteed as provided herein.

4. **Sales of Land Parcels.** No person shall sell or exchange or offer to sell or exchange any parcel of land which is in any part of a Subdivision or a larger tract of land or offer for a recordation in the County Recorder's Office, any deed conveying such a parcel of land or any interest therein, unless such Subdivision has been created pursuant to, and in accordance with, the provisions of this Title.
5. **Building Permits.** Building permits shall not be issued prior to approval and recordation of the final plat.

#### **11.02.02 Work to be Done by Registered Professional**

All plans must be prepared and stamped by licensed and/or certified professionals in the State of Utah including, but not limited to, architects, landscape architects, land planners, engineers, surveyors, geotechnical engineers, transportation engineers or other professionals as deemed necessary by the City.

#### **11.02.03 Approval Procedure**

1. **Approval Process.** The approval process for a Subdivision shall be in sequential order consisting of no more than four (4) review cycles:
  - a. Concept Plan (optional)
  - b. Preliminary Plat Review
  - c. Preliminary Improvement Plan Review
  - d. Final Plat and Improvement Plan Review
2. **Expiration.** Each Subdivision application review cycle shall be valid for a period of not more than one (1) year. At the request of the Subdivider, the Administrative Land Use Authority may grant up to two (2) six-month (6) extensions if substantial progress has been demonstrated by the Applicant. Expired applications shall be deemed null and void and require the Subdivider to start the Subdivision approval process over.

#### **11.02.04 Phasing**

Subdivisions may be done in phases. Each phase shall follow the Approval Procedure as outlined in 11.02.03.

1. The Preliminary Plat shall include all ground anticipated to be subdivided. The phases shall be shown as part of the Preliminary Plat and submitted with the Preliminary Plat.
2. Development shall be organized such that the phases will be contiguous, and the required improvements and infrastructure will be continuous as deemed feasible and desirable by the Administrative Land Use Authority.
3. Less desirable or expensive aspects of the Subdivision should not be delayed to the final phases of development.
4. The Administrative Land Use Authority may require a pro-rated portion of the improvements and infrastructure be developed, or guaranteed in escrow, in earlier phases.

5. Where it is prudent to install improvements and infrastructure that extend into the next phase, such work may be done when it is shown on the plans and approved accordingly.

**11.02.05 Rezone of Property**

If rezoning the property is required, the Applicant must first obtain rezone approval as required in City Code, prior to subdividing.

**11.02.06 Development Agreements**

Any Development Agreement proposed by the Applicant, or the City shall be approved prior to subdividing.

**11.02.07 Public Hearings**

The Planning Commission shall hold public hearings for the general plan, zoning map changes, and any other Land Use Ordinances, applications, and amendments for which a public hearing is required by statute. See, Utah Code Annotated 10-9a-103, 10-9a-404, 10-9a-502, 10-9a-503, 10-9a-602, and 10-9a-608. A public hearing shall not be held for administrative decisions except for conditional use applications.

**11.02.08 Application Requirements and Review Process**

Notwithstanding the specific requirements outlined in this Section for each Application, all proposed Subdivisions shall show compliance with all applicable laws and standards. Poorly drawn, incomplete, or illegible drawings shall be cause for denial. The Administrative Land Use Authority may waive certain informational and design requirements when they clearly do not apply and are irrelevant to a proposed Subdivision and shall state such waiver as part of the review cycle.

**11.03 CONCEPT PLAN**

1. **Purpose.** Prior to submitting a formal application, a prospective Applicant may request a meeting with city staff to obtain initial feedback and information. This meeting shall be optional, non-binding, and considered separate from and independent of the required Subdivision approval review cycles.

**11.04 PRELIMINARY PLAT AND IMPROVEMENT PLANS**

1. **Purpose.** For the Administrative Land Use Authority to complete an initial Subdivision Ordinance Review and an initial Subdivision Plan Review.
2. **Application Required.** The Applicant shall submit the required Preliminary Subdivision Plat Application for review and approval by the Administrative Land Use Authority.
  - a. **Exception.** When a proposed Subdivision does not involve the development of new public infrastructure, an exception may be granted by the City Engineer to waive, in writing, the need for the review of the Preliminary Improvement Plans.
3. **Complete Application.** An application shall not be considered complete and the first review cycle shall not begin unless and until the Applicant has submitted the following items:
  - a. A completed Preliminary Subdivision Plat Application as provided by the City.
  - b. Additional studies and information as listed on the application form and as necessary to show feasible compliance with applicable codes and regulations (see 11.07.01.4).
  - c. A signed Owner-Agent Affidavit (if the Owner is being represented by another party).

- d. Current Davis County ownership plat depicting property proposed for subdivision and all contiguous property around land proposed to be subdivided.
- e. A recent Title Report covering the proposed subdivided property identifying ownership, easements of record, liens or other encumbrances and verifies payment of taxes and assessments.
- f. Will serve letters from all applicable service providers.
- g. A digital copy of the preliminary plat as outlined in the Public Works Standards.
- h. A digital copy of the preliminary improvement plans to include at a minimum the following:
  - i. Grading and drainage plan.
    - A. Storm Drain calculations
    - B. Low Impact Design (LID) analysis and Water Quality Report
  - ii. Utility plan.
- i. Payment of fees as stated in the City's current adopted Fee Schedule.

**4. Time Frame.**

- a. **Location is Not Within 100 Feet of Water Conveyance Facility.** Within fifteen (15) business days after the receipt of the completed application, the Applicant shall receive written comments from the Administrative Land Use Authority.
  - i. After the Applicant's complete Response is received the Applicant will be placed on the agenda of the next regularly scheduled meeting of the Planning Commission for approval. The Planning Commission shall review the subdivision relative to the general plan and the provisions of this Title.
  - ii. Approval from the Planning Commission shall complete the Review Cycle.
- b. **Location is Within 100 Feet of Water Conveyance Facility.** Within twenty (20) calendar days after the receipt of the completed application, the City shall notify in writing the Water Conveyance Facility Owner(s) of the Application and request comments related to the following aspects of the water conveyance facility: access, maintenance, protection, safety, and any other issues related.
  - i. Within fifteen (15) business days after the twenty (20) calendar days comment period, whether comments are received from the Water Conveyance Facility Owner(s) or not, the Applicant shall receive written comments from the Administrative Land Use Authority. Total time frame shall not exceed forty (40) calendar days.
  - ii. After the Applicant's complete Response is received the Applicant will be placed on the agenda of the next regularly scheduled meeting of the Planning Commission for approval.
  - iii. Approval from the Planning Commission shall complete the Review Cycle.

- c. **Water Conveyance Facility.** Shall mean a ditch, canal, flume, pipeline, or other watercourse used to convey water used for irrigation or storm water drainage and any related easement for the ditch, canal, flume, pipeline, or other watercourse. *See State Code 73-1-15.5-1b.*

#### 11.05 FINAL PLAT AND IMPROVEMENT PLANS

1. **Purpose.** For the Administrative Land Use Authority to complete Final Subdivision Plat and Improvement Plans Review.
2. **Application Required.** The Applicant shall submit the required Final Subdivision Plat and Improvement Plans Application for review and approval by the Administrative Land Use Authority.
3. **Complete Application.** An application shall not be considered complete and the review cycle shall not begin unless and until the following items are submitted:
  - a. Preliminary approval by the Planning Commission.
  - b. Completion of all requirements from previous Review Cycle.
  - c. A completed Final Plat and Improvement Plans Application as provided by the City.
  - d. Additional studies and information as listed on the application form and as necessary to show feasible compliance with applicable codes and regulations (see 11.09.01.4).
  - e. A signed Owner-Agent Affidavit (if the Owner is being represented by another party).
  - f. Proof of tax clearance indicating that all taxes, interest, and penalties owing on the land have been paid.
  - g. Approval letter from secondary water provider(s).
  - h. Written approval from other agencies as applicable (e.g., Army Corps of Engineers, Utah Department of Transportation, Davis County Surveyor).
  - i. A digital copy of the final plat and improvement plans as revised and updated from the previous review cycle.
  - j. Plan and profile drawings for all existing and proposed infrastructure.
  - k. Final covenants, conditions, and restrictions (if applicable) which shall be recorded with the final plat.
  - l. Final agreements (if applicable) executed by all parties.
  - m. Engineer's Cost Estimate for all improvements and infrastructure that includes quantities, units, and costs for all improvements and infrastructure required.
  - n. Payment of fees as stated in the City's current adopted Fee Schedule.
4. **Signors of Plat**

- a. Mayor (as a non-discretionary and ministerial act for the acceptance of land and public improvements that may be proposed for dedication to the City);
  - b. City Recorder (attesting the Mayor’s signature);
  - c. City Planner;
  - d. City Engineer;
  - e. City Attorney;
  - f. Each Landowner on record as described on the plat – Owner’s Dedication as shown on the plat and notarized;
  - g. A surveyor who prepares the plat shall certify that the surveyor holds a license in accordance with State Code Title 58-22 and has completed a survey of the property, verifying all measurements, or has referenced a record of survey map of the existing property boundaries shown on the plat, and verified the locations of the boundaries and has placed monuments as represented on the plat.
5. **Review Cycle and Approval.** The Administrative Land Use Authority may complete up to three (3) final review cycles, as deemed necessary. After the Applicant has responded to either the fourth or final review cycle, and the Applicant has complied with each modification requested in the Administrative Land Use Authority’s previous review cycle, no additional reviews are required if the Applicant has not materially changed the plan – other than those changes in response to the requested modifications or corrections.
6. **Time Frame.** Within twenty (20) business days after the receipt of the completed application, the Applicant shall receive written comments from the Administrative Land Use Authority.
- a. **Appeal of Improvement Plans Approval.** If, on the fourth or final review, the Administrative Land Use Authority fails to respond within the time frame, the Applicant may make a formal request for a decision to approve or deny the final revised set of plans.  
  
Within ten (10) days of this request, the City shall assemble an appeal panel consisting of one (1) licensed engineer designated by the City, one (1) licensed engineer designated by the Applicant, and one (1) licensed engineer agreed upon and designated by the engineers selected by the City and the Applicant. No member of the panel may have any interest in the application that is the subject of the appeal.  
  
The Applicant shall pay fifty percent (50%) of the cost of the appeal review and the City’s fee as stated in the current adopted Consolidated Fee Schedule.  
  
The decision by the appeal panel shall be final, subject to a petition being filed within thirty (30) days of the decision in the District Court.
7. **Final Plat Approval – Notice Required.** Within thirty (30) days after approving a final plat, the municipality shall submit an electronic copy of the final approved plat to the Utah Geospatial Resource Center for inclusion in the unified statewide 911 emergency services database.

## 11.06 IMPROVEMENTS AND INFRASTRUCTURE

**11.06.01 General Requirements**

All improvements and infrastructure related to a Subdivision shall be installed according to the requirements of the City Code and the Public Works Standards. The Subdivider shall be responsible for extending all utilities and improvements and infrastructure to the Subdivision if they are not already adjacent to or on the site including curb, gutter, and sidewalk on streets operated by the Utah Department of Transportation. When the City is to take ownership of public infrastructure and improvements, the City shall require the Subdivider to install such improvements in a manner that does not cause excessive liability or maintenance costs for the City at the convenience or advantage of the Subdivider.

**11.06.02 Utilities Required**

The following utilities are required to be provided by the Subdivider to each lot:

1. **Culinary Water.** The water source shall be provided by South Weber City unless an alternative permanent source is approved by the City Engineer and the Davis County Health Department.
2. **Sewer.** The sewer service shall be provided by South Weber City through gravity collection lines. Public sewer lift stations are generally not permitted.
  - a. Public sewer lift stations may be granted by exception by the Administrative Land Use Authority and the City Engineer when a lift station is deemed clearly preferable to the interest of the City and gravity sewer is not feasible.
  - b. As determined by the Administrative Land Use Authority and the City Engineer, some property may not be developed if gravity sewer cannot be reasonably provided.
3. **Secondary Water.** Secondary water service shall be provided by the Davis and Weber Counties Canal Company, South Weber Irrigation Company, South Weber Water Improvement District, Weber Basin Water Conservancy District, or an alternative permanent source as approved by the City.
4. **Land Drain.** The land drain system must be installed in areas with shallow groundwater. If basements are eliminated and the geotechnical report can provide sufficient documentation that groundwater levels (including historical) are deep enough to eliminate the need for the land drain system, the Administrative Land Use Authority and the City Engineer may allow this requirement to be waived.
5. **Electrical Power.** The electrical power will be provided by Rocky Mountain Power (RMP), or their successors and all installations must follow RMP Standards.
6. **Natural Gas.** The natural gas service will be provided by Dominion Energy, or their successors, and all installations must follow Dominion Energy Standards.

**11.06.03 Storm Water**

Storm water plans shall meet the requirements of the Public Works Standards and the City Code. The City Engineer shall determine the appropriate implementation strategy for meeting the City's storm water-related standards, using the current Capital Facilities Plan as a guide; this may include decisions regarding ownership and access to storm water ponds, and where and how the water shall flow as part of the City's overall storm water system.

**11.06.04 Inspections**

All improvements and infrastructure shall receive inspections by the City Engineer and/or City Public Works Department as required in the Public Works Standards and as necessary to verify conformance with the City Code and the Public Works Standards. Failure to obtain the necessary inspections shall result in a fine as outlined in this Title. Failure to obtain the necessary inspections may also necessitate removal and re-installation of the improvements and infrastructure at the Subdivider's sole cost, as such removal and re-installation are determined by the City Engineer and/or Public Works Department.

#### **11.06.05 Fee in lieu of Actual Improvements**

Subdivisions adjacent to a rural road or another road where the surrounding area is lacking public improvements and infrastructure may request the option to pay a fee in lieu of constructing the required improvements and infrastructure. The Administrative Land Use Authority and City Engineer may also require payment of the fee in lieu to make improvements as a part of a larger future project. An Agreement approving the payment of the fee in lieu may be approved during the Preliminary Improvement Plans Application phase by the Administrative Land Use Authority and City Engineer. Fee in lieu Agreements should only be approved when it is unreasonable or undesirable for the improvements and infrastructure to be installed with the development. The Agreement should include:

1. A calculation of the cost of the improvements not being installed.
2. For areas where the future project date is known, inflation costs at a maximum of 3% per year may be used up to the project year. For areas where the future project date is not known, inflation costs may only be included at a maximum of 3% per year for 5 years.
3. For areas where off-site improvements have already been constructed and excess capacity exists that was paid for by the city, Subdividers may "buy in" to the existing improvements to meet their requirements. A determination of available excess capacity and cost will be evaluated by the City Engineer.

### **11.07 ENGINEERING AND DESIGN REQUIREMENTS**

#### **11.07.01 General Requirements**

1. **Access.** All lots shall be accessed by a fully improved city street and shall meet the frontage requirements as stated in Title 10, Zoning Regulations. It shall be the responsibility of the Subdivider to provide proper road access to the Subdivision as required in the City Code, the Public Works Standards, and (where applicable) the Utah Department of Transportation. The mere existence of a public road or right-of-way to the proposed Subdivision does not mean that adequate access exists. It shall be the Subdivider's responsibility to construct and dedicate all public roads required by the City to provide access to the Subdivision.
2. **Design Standards.** All Subdivisions shall comply with the current adopted design standards set forth in the City Code and in the Public Works Standards.
3. **Public Infrastructure and Improvements.** The City Engineer shall have authority to require adjustments to the utility plan associated with a proposed Subdivision including adjustments to the type, manner, and location of utilities. Such adjustments to the utility plan may be required to provide connectivity among developments, provide for public safety, and minimize public infrastructure maintenance and liability.
4. **Additional Reports and Studies.**



- a. Geotechnical reports as required by the Public Works Standards and the City Engineer.
  - b. A traffic study may be required by the City Engineer depending on his/her judgment regarding the size of the Subdivision, complex traffic movements involved with the proposal, interaction of streets with State roads, new traffic patterns, traffic volume in or near the Subdivision, history of crashes or expected crashes in the area, general safety, or anticipated traffic delays due to the Subdivision.
  - c. Storm water pollution protection as required by the Public Works Standards and City Code.
  - d. Wetland delineation and mitigation may be required as determined by the City Engineer.
5. **Preservation of Natural Conditions.** The design and development of Subdivisions shall preserve insofar as possible the natural terrain, natural drainage, existing topsoil, and trees as determined by the Administrative Land Use Authority for the Preliminary Subdivision Applications.
6. **Hazards.** Land subject to hazardous conditions such as slides, mud flows, rock falls, faults, snow avalanches, possible mine subsidence, shallow water table, open quarries, floods, and polluted or non-potable water supply shall not be subdivided until complete mitigation of the hazards has been properly identified and included in the Subdivision Improvement Plans (see also Title 10-14).

#### **11.07.02 Street Layout and Access**

1. **General.** All streets shall conform, as much as practicable, to the adopted General Plan, Transportation Master Plan, and the Public Works Standards.
2. **Approval.** Overall street layout and access shall be reviewed and approved as part of the Preliminary Subdivision Applications. The Administrative Land Use Authority shall have authority to require stub roads, additional access into the development, and adjustments to the street layout, street cross-section, and right of way widths. Such adjustments to the Subdivision plan may be required to provide connectivity among developments, provide for public safety and emergency access, minimize public infrastructure maintenance and liability, and align with the General Plan and adopted transportation plans.
3. **Required Ingress/Egress Access.**
  - a. Developments where the number of residential building units exceeds thirty (30) along a single street shall have a minimum of two (2) ingress/egress routes which are two (2) fully improved City rights-of-way. Thirty (30) residential units shall include all proposed residential units and all existing single-family buildings and lots, empty building lots, and each apartment unit located along a single road up to and including the nearest intersection with two (2) existing means of ingress/egress.
  - b. A development that extends more than one thousand eight hundred feet (1,800') from a connecting street must provide a second ingress/egress.
4. **Exceptions.** The Administrative Land Use Authority for the Preliminary Subdivision Applications may waive these access requirements for more than thirty (30) residential units with one point of improved ingress/egress when unique topographic circumstances or "landlocked" (physically restrained from other access points) from adjacent, existing

developments circumstances exist. A waiver of these regulations may require additional development requirements to ensure public safety standards are met.

5. **Private Rights-Of-Way.** Private rights-of-way may be used for development purposes in all zoning districts subject to the following conditions:
  - a. Private rights-of-way shall be designed and built as per the South Weber City Public Works Standard Drawings.
  - b. Private rights-of-way shall meet the provisions of the zoning district.
  - c. Private rights-of-way shall not be permitted for any portion of road that is contained on the South Weber City Transportation Map.
  - d. Private rights-of-way shall not be permitted if the road serves to connect other rights-of-way or subdivisions.
  - e. Private rights-of-way shall meet all requirements of the international fire code, appendix D.
  - f. All development on private rights of way of two (2) lots or more shall establish a homeowners' association or similar organization that will be responsible for the care and maintenance of any common property or utilities. A complete set of covenants, conditions, and restrictions (CC&Rs) shall outline the care and maintenance of all private utilities, street improvements and common spaces. The CC&Rs shall also set forth the funding mechanism for that maintenance. The CC&Rs shall be recorded and run with the land.
  - g. An easement for all public utilities shall be provided and dedicated to the city.
  - h. Private Rights-Of-Way; Maintenance: The City will not be responsible in any way for maintenance or upkeep of surface improvements for private rights-of-way and does not guarantee services like mail or garbage collection will extend to the residences on such streets.

#### **11.07.03 Trails**

1. **Required.** Where a proposed Subdivision includes or adjoins an existing or planned public trail system as specified in the City's General Plan or Trails Master Plan the Subdivision plat shall include and provide for the development of a public trail infrastructure in accordance with said Plan.
2. **Improvements.** Trails shall be developed in accordance with applicable AASHTO standards with sufficient width, and to safely accommodate two-way bicycle and pedestrian traffic along the trail corridor. In absence of applicable AASHTO standards, the Davis County Trails Standards are hereby adopted and applied.
  - a. The Administrative Land Use Authority, when feasible, may allow the trail right-of-way to be a substitute for required sidewalk and park strip area on one side of the street right-of-way dedicated within the Subdivision.
  - b. All trail improvements shall be dedicated to the City or an agreed upon non-profit third party, for the operation and maintenance after final acceptance.

#### **11.07.04 Fencing**

1. **Purpose.** Provide increased safety from potential dangers due to agricultural activities, water courses, high-speed traffic, and other potential dangers or hazards by requiring a barrier between potentially incompatible land uses.
2. **Requirement.** Fencing shall be required under the following conditions:
  - a. **Bordering Agricultural Land.** A six foot (6') high fence is required between the subdivision (any zone) and any land that is zoned Agricultural (A).
    - i. Fencing material shall be chain link unless otherwise approved according to 11-07-04-3.
  - b. **Bordering Canals.** A six foot (6') high fence is required where the subdivision borders a canal, canal right-of-way / easement, or canal property whereon the canal is located.
    - i. Fencing material shall be chain link unless otherwise approved according to 11-07-04-3.
  - c. **Bordering Interstate.** A six foot (6') high fence is required where building lots for any land use are adjacent to Interstate 84. The fence shall be installed along the I-84 right-of-way line.
    - i. The fencing material shall be masonry unless otherwise approved according to 11-07-04-3.
  - d. **Buffer Yard.** An eight foot (8') high fence/wall as required by Title 10-15-14.
    - i. Fencing/wall material shall be masonry unless otherwise approved according to 11-07-04-3.
  - e. **Multiple Conditions.** In the case where one or more of the fencing conditions listed above exist in the same location, the more restrictive requirement shall govern.
3. **Other Fencing Materials.** The listed material shall be required unless a different type of fencing material matches the look and feel of other adjacent fencing materials as requested by the applicant and approved by the Administrative Land Use Authority. In no case can the quality or purpose be less than the listed size and material.
4. **Authority.** The Administrative Land Use Authority shall have authority to implement reasonable fencing requirements for conditions other than those stated above where potential dangers are currently present or will be present after the development of the subdivision. The Administrative Land Use Authority shall also have the authority to waive the fencing requirement where its removal will not compromise safety or does not accomplish the intent of the fence.

**11.07.05 Street Lighting**

1. The subdivider shall pay for all outdoor street lighting fixtures.
2. The placement and installation of street lighting shall be in accordance with the adopted Development, Design, and Construction Standards.
3. The subdivider shall be required to get power installed into the subdivision and notify the City when power is available.

4. The City is responsible for ordering the streetlights. The streetlights shall then be installed and maintained by the City's authorized contractor.

**11.07.06 Easements**

1. **General Utility Easements.** A minimum ten foot (10') general utility easement shall traverse the frontage(s) of each lot. The Administrative Land Use Authority may require additional easements to accommodate utility planning and future access.

**11.07.07 Lots and Parcels**

1. The lot arrangement, design and shape shall be such that lots will provide satisfactory and desirable sites for structures and be properly related to topography and conform to requirements set forth herein. Side lines of lots shall be approximately at right angles, or radial to the street line whenever possible and desirable.
2. Lots shall not contain peculiarly shaped elongations solely to provide necessary square footage or frontage, which would be unusable for normal purposes.
3. For Subdivisions containing more than two (2) residential building lots, no lots shall directly access an arterial or collector street.
4. All lots shown on the final plat must conform to the minimum requirements of the zoning code for the zone in which the Subdivision is located, except for remainder parcels as follows:
  - a. May be used for agricultural purposes but shall not be eligible for habitation, commercial uses, or primary structures.
  - b. May not be eligible for building permits and may not be eligible for other permitted uses. All limitations and restrictions shall be clearly noted on the final plat.
  - c. Shall be described on the final plat; however, an exception may be granted by the City Engineer.
5. Each lot shall have frontage on an improved public road as required in the zoning code and the Public Works Standards unless a permanent access easement and shared driveway has been approved.
6. All remnants of land left over after subdividing, shall be attached to adjacent lots or made part of the common area governed by a Community/Homeowners Association, rather than allowed to remain as unusable parcels. All lands within the boundaries of the Subdivision shall be accounted for, either as lots, right of way, or as remainder parcels.
7. Lots having double frontage shall not be approved except where necessitated by topographic or other unusual conditions or where the lots are adjacent to a road that does not permit direct access (exception: corner lots).
8. Contiguous parcels owned by different parties may be embraced in one final plat, provided that all Owners join in the dedication and acknowledgments.
9. A lot shall not be divided by a city limit or county limit line. Such boundary lines shall be made at lot lines.

**11.07.08 Utilities to be Underground**

1. All utilities, including those that are normally overhead shall be placed underground in all Subdivisions. The Subdivider shall establish final utility grades prior to utilities being placed underground.
  - a. Exception: wireless communication equipment or where underground connection is not permitted by the Provider.

**11.08 DEVELOPMENT ACTIVITY PRIOR TO PLAT RECORDING**

1. **Pre-Construction Meeting.** Upon completion of the Final Plat and Improvement Plans Review Cycle and prior to commencing any construction activity, the Applicant shall schedule and attend a pre-construction meeting as required in the City's Public Works Standards for Development, Design, and Construction.
  - a. If the General Contractor changes at any time during construction, an additional pre-construction meeting shall be held before additional work commences.
2. **Inspections.** All construction shall be subject to inspections as required in the City's Public Works Standards for Development, Design, and Construction.
3. **Improvement Completion Assurance.** At any time after receiving final approval, the Applicant may post an improvement completion assurance as outlined in 11.02.09 for:
  - a. Completion of one hundred percent (100%) of the required public improvements or infrastructure; or
  - b. If the City has inspected and accepted a portion of the public improvements, one hundred percent (100%) of the incomplete or unacceptable public improvements or infrastructure.

**11.08.01 Subdivision Plat Recording**

1. After the plat has been acknowledged, certified, and approved, the City Recorder shall record the plat in the office of the County Recorder.

**11.08.02 Improvements Completion Assurance and Guarantee of Performance**

1. **Purpose.** To assure the completion of required improvements and infrastructure as required by the approved plans, Public Works Standards, and all applicable ordinances, the Subdivider shall establish a Cash Escrow account or Letter of Credit guarantee with a federally insured financial institution.

This completion assurance shall be established prior to recording the Subdivision plat. If the Subdivider installs the infrastructure and improvements and such infrastructure and improvements are inspected and approved by the City prior to recording the plat, then only warranty portion of the completion assurance shall be required.

The provisions of this section do not supersede the terms of a valid Development Agreement, an adopted phasing plan, or the State Construction Code.

2. **Cost Estimate.** The Subdivider shall submit an updated Engineer's Cost Estimate for all improvements and infrastructure required within the Subdivision. The cost estimate shall

include quantities, units, and costs for all improvements and infrastructure required, and shall indicate which items have already been installed.

The City Engineer shall review and approve the cost estimate and may adjust the costs to meet current industry standards. Those items that are deemed “direct costs” shall be removed from the escrow and shall be accounted for separately.

3. **Guarantee Amount.** The guarantee shall be equal to one hundred ten percent (110%) of the cost estimated and approved by the City Engineer.
  - a. One hundred percent (100%) shall be for the cost of those improvements and infrastructure not yet installed; and
  - b. Ten percent (10%) shall be for a required one-year (1) warranty period (see Subsection 11.09-4). The warranty amount calculated shall be based upon the total cost of all required improvements and infrastructure.
4. **Liability.** The Subdivider and/or contractor shall indemnify and hold harmless the City and its officers, directors, members, partners, agents, employees, and consultants from all claims, damages, losses, and expenses, including attorney’s fees, arising out of, or resulting from the installation of the required improvements and infrastructure. The indemnity required hereby shall be included in the applicable Escrow Agreement.
5. **Default.** In the event the Subdivider is in default with any provision of this Section, or fails or neglects to satisfactorily install the required improvements and infrastructure within two (2) years from the date of approval of the final plat, or to pay all liens in connection therewith, or to correct deficiencies or damages to the improvements and infrastructure required for final acceptance (see Subsection 10 hereof), the City may declare the escrow forfeited and the City may install, repair, or cause the required improvements and infrastructure to be installed or repaired, using the proceeds from the collection of escrow to defray the expense thereof.

The City may apply all sums deposited in escrow against the cost of completing all required improvements and infrastructure and to pay all expenses, including, but not limited to, all unreimbursed engineering expenses related to the development, a ten percent (10%) administration fee for the securing of contracts, and court costs and attorney fees. The default provisions required hereby shall be included in the applicable Escrow Agreement.

6. **Release of Funds.** The Subdivider shall be responsible for the quality of all materials and workmanship. If improvements and infrastructure are properly installed and verified via City inspections and testing, liens are paid, and other conditions are found to be satisfactory, then the City’s Escrow Agent shall authorize the money held in escrow for the specific improvement completed (except for the 10% held during the hereinafter described warranty period) to be released. If the conditions of material or workmanship show unusual depreciation, or do not comply with the acceptable standards of durability, or if required inspections or testing have not been done, or if any outstanding liens are not paid, then the City may withhold releasing the money and the City may declare the Subdivider in default. The City shall have exclusive control over the release of the escrow funds, and they may be released only upon written approval by the City.
7. **Direct Costs.** The Subdivider shall pay the following direct costs at the time they establish the required Improvements Completion Assurance. The funds collected for each item will be used

for the construction and installation of said items by the city; thus, removing the Subdivider's responsibility for the installation of these items as part their development:

- a. Half percent (0.5%) of the total construction cost shall be to cover administrative costs.
- b. Funds for the current Public Works Standard seal coat treatment. The amount shall be established by the City Engineer in accordance with recent bid prices received for similar treatment(s).
- c. Funds for current Public Works Standard Streetlights and all associated infrastructure costs.
- d. Funds for current Public Works Standard Street Signs.
- e. Funds for mailbox combination boxes, if Subdivider would like them to be installed by the city (optional).
- f. Funds associated with any cost agreement(s) with the city that was established as a condition of approval.

#### **11.09 DEVELOPMENT ACTIVITY AFTER PLAT RECORDING**

1. **Improvements and Infrastructure Required for Building Permit.** No building permit shall be issued by the City unless all required improvements are installed, inspected, and approved, with the exception of sidewalk, asphalt pavement, streetlights, and street signs.
2. **Improvements and Infrastructure Required for Occupancy.** No occupancy permit shall be issued by the City unless all required improvements are installed, including the sidewalk along the frontage of the building lot in question, but with the exception of streetlights and street signs.
3. **Conditional Acceptance of Improvements and Infrastructure.** The City Engineer shall issue conditional acceptance upon the following:
  - a. Completion of all required improvements and infrastructure.
  - b. The site has been left in an orderly and clean condition following construction. Construction waste, debris, excess fill material, or any other similar material shall not be left or abandoned on the site or on other nearby properties.
  - c. The final plat has been recorded.
  - d. The Subdivider makes a written request for inspection of improvements and infrastructure for the purpose of conditional acceptance.
    - i. The city will generate a written punch list of items needing repair, replacement or yet to be completed.
  - e. Improvements and infrastructure are inspected by the City and found to be acceptable and in compliance.
    - i. Completion of all items identified on the punch list.
  - f. Reproducible as-built drawings have been submitted to and accepted by the City Engineer.

4. **Warranty Period.** Upon receipt of Conditional Acceptance, all required improvements and infrastructure shall be warranted by the Subdivider for a period of one (1) calendar year.
5. **Final Acceptance.** Following the completion of the Warranty Period, the Public Works Director shall issue final acceptance of the Subdivision improvements and infrastructure when:
  - a. The Subdivider makes a written request for inspection of improvements and infrastructure for the purpose of Final Acceptance.
    - i. The city will generate a written punch list of items needing repair or replacement.
  - b. Improvements and infrastructure are inspected by the City and found to be acceptable and in compliance.
    - i. Completion of all items identified on the punch list.
6. **Release of Remaining Escrow.** Upon acceptance by the City Engineer, the City's Escrow Agent shall authorize the release of all remaining escrow monies.

## **11.10 VARIANCES AND APPEALS**

### **11.10.01 Variances and Appeals Generally**

Any Person may petition for a variance or appeal a decision pertaining to this Title to the Appeal Authority as established in Title 10-4, Appeal Authority.

### **11.11 PENALTY**

1. Any Person, who shall transfer or sell, or cause to be transferred or sold, any lot or land in a Subdivision, which Subdivision has not been approved by the City, and recorded in the office of the County Recorder, shall be guilty of a Class B misdemeanor for each lot or parcel of land so transferred or sold, and the description of such lot or parcel of land by metes and bounds in the instrument of transfer, or other document used in the process of selling or transferring, shall not exempt the transaction from such penalties or from the remedies provided in this Title. The City may enjoin such transfer or sale or agreement by action for injunction brought in any court of equity jurisdiction, or may recover the penalty by civil action in any court of competent jurisdiction, together with costs and attorney fees incurred in enforcing this Title.
2. Any Person violating any of the provisions of this Title shall be guilty of a Class B misdemeanor.
3. Any Person violating any of the provisions of this Title or the Public Works Standards or failing to obtain the necessary inspections and tests required for public improvements and infrastructure shall be assessed a fine as stated in the City's current adopted Consolidated Fee Schedule. Fines may be applied daily and separately for each violation.
4. The City may bring an action against an Owner to require the property to conform to the provisions of this Title, the zoning ordinance, or any other applicable Law. The action may include an injunction, abatement, merger of title, or any other appropriate action or proceedings to prevent, enjoin, or abate the violation. The City need only establish the violation to obtain the injunction.

## **11.12 VACATING OR ALTERING A SUBDIVISION FINAL PLAT, VACATING A STREET, RIGHT OF WAY, OR EASEMENT, AND PARCEL ADJUSTMENTS**



**11.12.01 Vacating, Altering, or Amending a Final Plat**

1. Vacating, altering, or amending a final plat shall be done in accordance with Utah Code Annotated 10-9a-608, or its successor statute. This includes changing a Subdivision boundary, dedicated right of way, the number or layout of lots, easements, the Subdivision name, and any other aspect of a recorded final plat. If an amendment proposes significant changes to the existing Subdivision, then the Administrative Land Use Authority may require the changes to be made through the vacation of the existing final plat and/or approval of the changes being done through the process required for new Subdivisions; this should be done to ensure that significant changes receive proper review and adequate fees are obtained to cover costs to the City.
2. The Administrative Land Use Authority for vacating, altering, or amending a final plat shall be the same as that for the final plat application.

**11.12.02 Vacating a Street, Right of Way, or Easement**

1. Vacations shall be done in accordance with Utah Code Annotated 10-9a-609.5 or its successor statute.
2. The Administrative Land Use Authority shall be the City Council.
3. Adjusting or modifying an existing street, right of way, or easement while not eliminating the street, right of way, or easement, and while still maintaining access, does not constitute a vacation.

**11.13 EXEMPTIONS FROM PLAT; PARCEL AND LOT LINE ADJUSTMENTS**

**11.13.01 Purpose**

1. The purpose of this chapter is to outline the requirements and procedures for parcel line adjustments and lot line adjustments in accordance with Utah State Code and local land use regulations. The intent of this chapter is to allow owners of real property to adjust common property lines while minimizing delay and expense without the need of a subdivision plat.

**11.13.02 Parcel Boundary Adjustments Not in a Recorded Subdivision**

1. **Approval Required.** Prior to the recording of a parcel line adjustment between adjoining properties not located within a platted subdivision, the adjustment must first be approved by the Administrative Land Use Authority if the any of the properties involved includes a dwelling unit.
  - a. **Exemption:** Approval is not required prior to recording of a parcel line adjustment if the properties involved do not contain a dwelling unit.
2. **Review.** Application and the review of a proposed parcel line adjustment shall follow the procedures listed below:
  - a. **Application.** An applicant, either an owner of one of the properties or a representative of the owners, shall submit a complete application which shall include:
    - i. Property owner(s) affidavit acknowledging the consent of each party for the proposed adjustment.

- ii. Property survey(s) with all existing improvements to the properties;
  - iii. A legal description of the proposed parcel line and of each parcel after the boundary line is changed;
  - iv. A site plan or exhibit serving as a visual depiction of the parcel line adjustment;
  - v. Any necessary improvement plans, agreements, or additional materials needed for review as determined by the Administrative Land Use Authority.
- b. **Review Procedure.** Upon receipt and payment of a complete application, the Administrative Land Use Authority shall commence the review of the parcel line adjustment request. The review shall be completed, with a written response returned to the applicant, within fourteen (14) business days from the date of complete application. The reviewing parties shall review the adjustment for compliance with city zoning and public works standards.
3. **Final Approval.** If the proposed parcel line adjustment complies with all city ordinances and development standards, written approval shall be provided to the applicant by the City Planner or designee.
4. **Recording.** Upon final approval from the Administrative Land Use Authority, the applicant shall record the approved documents at the office of the Davis County Recorder to complete the parcel line adjustment. The parcel line adjustment may be completed by a quitclaim deed or boundary line agreement and shall be accompanied by the following:
  - a. The written notice of approval of the parcel line adjustment by South Weber City that recites the legal descriptions of both the original parcels and the parcels resulting from the exchange of title;
  - b. The approved site plan or exhibit depicting the new parcel boundaries and adjacent properties if deemed necessary; and
  - c. Any other documents deemed necessary as part of the parcel line adjustment approval.
5. **Exception.** If the parcel line adjustment is creating a new parcel(s) for the purpose of constructing a dwelling unit, a subdivision plat must be approved, and the provisions of this title must be followed.
6. All parcel line adjustments shall comply with applicable state code regulations found under sections 10-9a-523 (property boundary adjustment) and 10-9a-524 (boundary line agreement). A parcel line adjustment shall follow the procedures provided herein unless exempted from local land use authority review as provided in the forementioned state code sections.

### **11.13.03 Lot Line Adjustments within a Recorded Subdivision**

1. **Approval Required.** Prior to the recording of a lot line adjustment between adjoining properties within a platted subdivision, the adjustment must first be approved by the Administrative Land Use Authority.
2. **Review.** Application and the review of a proposed lot line adjustment shall follow the procedures listed below:

- a. **Application.** An applicant, either an owner of one of the properties or a representative of the owners, shall submit a complete application which shall include:
  - i. Property owner(s) affidavit acknowledging the consent of each party for the proposed adjustment between the lots.
  - ii. Property survey(s) with all existing improvements to the lots and reference to the subdivision within which the properties are located including easements located on the lots;
  - iii. A legal description of each of the proposed lots after the lot line is changed including any changes to platted easements associated with the lots;
  - iv. A site plan or exhibit serving as a visual depiction of the lot line adjustment. Although not a plat, the site plan or exhibit shall sufficiently represent the new lots and include adjacent lots within the subdivision;
  - v. Any necessary improvement plans, agreements, or additional materials needed for review as determined by the City Planner, City Engineer, or designees.
- b. **Review Procedure.** Upon receipt and payment of a complete application, the Administrative Land Use Authority shall commence the review of the lot line adjustment request. The review shall be completed, with a written response returned to the applicant, within fourteen (14) business days from the date of complete application. The reviewing parties shall review the adjustment for compliance with city zoning and public works standards.
3. **Final Approval.** If the proposed lot line adjustment complies with all city ordinances and development standards, written approval shall be provided to the applicant by the City Planner or designee.
4. **Recording.** Upon final approval from the Administrative Land Use Authority, the applicant shall record the approved documents at the office of the Davis County Recorder to complete the lot line adjustment. The lot line adjustment may be completed by quitclaim deed or boundary line agreement and shall be accompanied by the following:
  - a. The written notice of approval of the lot line adjustment by South Weber City that recites the legal descriptions of both the original lots and the lots resulting from the exchange of title;
  - b. The approved site plan or exhibit depicting the new lot boundaries along with adjacent lots within the subdivision; and
  - c. Any other documents deemed necessary as part of the lot line adjustment approval.
5. **Exception.** If the lot line adjustment is creating a new lot(s) or parcel(s) for the purpose of constructing a dwelling unit, a subdivision plat must be approved, and the provisions of this title must be followed.
6. All lot line adjustments shall comply with applicable state code regulations found under section 10-9a-608 (5). A lot line adjustment shall follow the procedures provided herein unless an amended plat is required per state statute.

## **11.14 EXEMPTIONS FOR BONA FIDE AGRICULTURAL AND UTILITY SERVICE PURPOSES**

### **11.14.01 Purpose and Intent**

Utah Code 10-9a-605(2) exempts agricultural lands from plat requirements under the certain conditions therein.

### **11.14.02 Qualifications of Land for Agricultural Purposes**

Agricultural land may be divided or partitioned under this Chapter only under the following circumstances:

1. The property must have been solely for agricultural use and actively devoted to agricultural use as defined by Utah Code 59-2-502 and must continue to be used solely for agricultural use in the future.
2. All of the lots or parcels must meet the minimum lot size requirements of the applicable zoning district.

### **11.14.03 Agricultural Partition Parcels as Buildable Lots**

An agricultural partition lot is buildable for only bona-fide agricultural purposes. A parcel created in accordance with this Chapter is not considered a buildable lot for residential, commercial, industrial, or any other non-agricultural purposes.

### **11.14.04 Public Improvements and Infrastructure**

The City shall not require any public improvements and infrastructure to be installed as a condition of approval for agricultural partitions.

### **11.14.05 Use of Property Created Under This Part for Non-Agricultural Purposes**

If a lot or parcel created by this part is used for a non-agricultural purpose, the City shall require the lot or parcel to comply with the requirements of the Subdivision and land use provisions of the City.

### **11.14.06 Utilities**

A Subdivision of land for utility purposes (unmanned facilities such as: substations, regulator stations, towers, etc.) creating a parcel(s) under eight thousand square feet (8,000 ft<sup>2</sup>) in size may be exempted by the Administrative Land Use Authority for certain provisions of this Title and/or provisions of City Code relating to lot size, frontage, setbacks, and improvements and infrastructure.

### **11.14.07 Parent Parcels**

The parent parcel from which the agricultural or utility lot(s) is created shall be labeled as a remainder parcel and shall not be part of an approved Subdivision until such time as it complies with the provisions of this Title and other relevant sections of the City Code and has received the applicable land use approval(s).

1. The property must have been solely for agricultural use and actively devoted to agricultural use as defined by Utah Code 59-2-502 and must continue to be used solely for agricultural use in the future.
2. All of the lots or parcels must meet the minimum lot size requirements of the applicable zoning district.

**11.14.03 Agricultural Partition Parcels as Buildable Lots**

An agricultural partition lot is buildable for only bona-fide agricultural purposes. A parcel created in accordance with this Chapter is not considered a buildable lot for residential, commercial, industrial, or any other non-agricultural purposes.

**11.14.04 Public Improvements and Infrastructure**

The City shall not require any public improvements and infrastructure to be installed as a condition of approval for agricultural partitions.

**11.14.05 Use of Property Created Under This Part for Non-Agricultural Purposes**

If a lot or parcel created by this part is used for a non-agricultural purpose, the City shall require the lot or parcel to comply with the requirements of the Subdivision and land use provisions of the City.

**11.14.06 Utilities**

A Subdivision of land for utility purposes (unmanned facilities such as: substations, regulator stations, towers, etc.) creating a parcel(s) under eight thousand square feet (8,000 ft<sup>2</sup>) in size may be exempted by the Administrative Land Use Authority for certain provisions of this Title and/or provisions of City Code relating to lot size, frontage, setbacks, and improvements and infrastructure.

**11.14.07 Parent Parcels**

The parent parcel from which the agricultural or utility lot(s) is created shall be labeled as a remainder parcel and shall not be part of an approved Subdivision until such time as it complies with the provisions of this Title and other relevant sections of the City Code and has received the applicable land use approval(s).

## **EXHIBIT 4**

# **DEVELOPMENT, DESIGN, AND CONSTRUCTION STANDARDS FOR SOUTH WEBER**

South Weber City Corporation

# Development, Design, & Construction Standards



December 2023

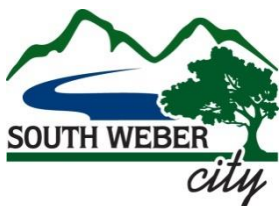

Prepared by  
**JONES & ASSOCIATES**  
*Consulting Engineers*



DEVELOPMENT, DESIGN, AND  
CONSTRUCTION STANDARDS  
for  
SOUTH WEBER CITY

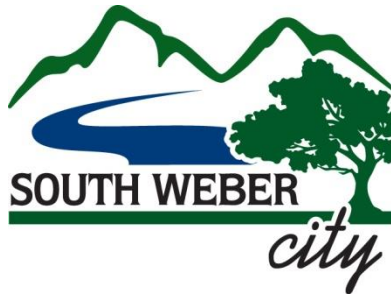

**SUBMITTED & RECOMMENDED:**

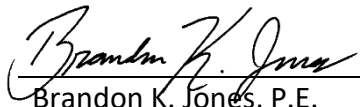
  
\_\_\_\_\_  
Brandon K. Jones, P.E.  
City Engineer

12/31/23  
Date

**APPROVED:**

\_\_\_\_\_  
Rod Westbroek  
Mayor

12/31/23  
Date

\_\_\_\_\_  
David J. Larson  
City Manager

12/31/23  
Date

\_\_\_\_\_  
Trevor Cahoon  
Community & Planning Director

12/31/23  
Date

\_\_\_\_\_  
Mark B. Larsen  
Public Works Director

12/31/23  
Date

\_\_\_\_\_  
Lisa Smith  
Attest, City Recorder

12/31/23  
Date



**TABLE OF CONTENTS**

SECTION 1 GENERAL ..... 1

    1.01 South Weber City Municipal Code Governs..... 1

    1.02 Conformance with Federal, State, and Local Laws ..... 1

    1.03 Definitions..... 1

    1.04 Acronyms ..... 2

    1.05 Modification Process..... 2

SECTION 2 DEVELOPMENT STANDARDS ..... 4

    2.01 Approval Procedure ..... 4

    2.02 Developer Responsibilities..... 4

    2.03 Subdivision Standards ..... 5

    2.04 Geotechnical Investigation ..... 5

SECTION 3 DESIGN STANDARDS ..... 6

    3.01 Required Improvements ..... 6

    3.02 Improvement Plans ..... 8

    3.03 Sanitary Sewer Design..... 10

    3.04 Water Design..... 10

    3.05 Street/Road Design ..... 11

    3.06 Storm Drain and Drainage Design..... 12

SECTION 4 CONSTRUCTION STANDARDS..... 13

    4.01 General Policies..... 13

    4.02 Pre-Construction Meeting..... 16

    4.03 Construction..... 16

SECTION 5 TECHNICAL SPECIFICATIONS ..... 20

    5.01 Technical Specifications for South Weber City ..... 20

    5.02 Order of Precedence ..... 20

SECTION 6 STANDARD DRAWINGS, PLANS, AND DETAILS..... 21

    6.01 Standard Drawings, Plans, and Details for South Weber City..... 21

    6.02 Order of Precedence ..... 21

**APPENDICES**

- A STORM DRAIN AND DRAINAGE DESIGN STANDARDS
- B GEOTECHNICAL INVESTIGATION REPORT MINIMUM REQUIREMENTS
- C MODIFICATIONS AND ADDITIONS TO MANUAL OF STANDARD SPECIFICATIONS
- D SOUTH WEBER CITY PUBLIC WORKS STANDARD DRAWINGS

## **SECTION 1      GENERAL**

### **1.01      South Weber City Municipal Code Governs**

Nothing in this document shall be construed to be contrary to South Weber City Municipal Code. Should a conflict exist between this document and the Ordinances, the Code shall govern.

### **1.02      Conformance with Federal, State, and Local Laws**

Nothing in this document shall relieve the Developer, Engineer, or Contractor from abiding by any and all Federal, State, and local laws.

### **1.03      Definitions**

- A. Title or Chapter – When “Title” or “Chapter” is written, it shall be as if “South Weber City Ordinance, Title (or Chapter)” is written.
- B. Contractor – The individual, firm, co-partnership, or corporation, and his, their, or its heirs, executors, administrators, successors, and assigns, or the lawful agent of any such individual firm, partnership, covenantor, or corporation, or his, their, or its surety under the contract bond, constituting one of the principals to the contract and undertaking to perform the Work.
- C. Drawings – The City-approved construction drawings, the South Weber City Public Works Standard Drawings, and/or the Manual of Standard Drawings, as applicable.
- D. Developer – The person sponsoring construction of the improvements.
- E. Development – The subject subdivision, minor subdivision, or building.
- F. Improvements – See “Work.”
- G. Improvement Plans – See “Drawings.”
- H. Inspector – The authorized representative of the City or City Engineer assigned to make all necessary inspections of the Work performed or being performed, or of materials furnished or being furnished by the Contractor.
- I. Work – All types of work necessary to provide safe access and utility service to and within proposed subdivision or site, including, but not limited to, site grading, utility installation, and street construction. Work includes all labor, services, and documentation necessary to produce such construction; furnishing, installing, and incorporating all materials and equipment into such construction; and may include related services such as testing, start-up, and commissioning.<sup>1</sup>
- J. See also the South Weber City Municipal Code, Title 11 Subdivision Regulations. Where definition conflicts arise between City Ordinance and this document, the definitions in this document shall take precedence when in reference to this document.

---

<sup>1</sup> From EJCDC® C-700, Standard General Conditions of the Construction Contract.

**1.04 Acronyms**

- A. BMP – Best Management Practice
- B. CFP – Capital Facilities Plan
- C. DDW – Division of Drinking Water
- D. DWQ – Division of Water Quality
- E. DWRi – Division of Water Rights
- F. FEMA – Federal Emergency Management Agency
- G. HOA – Homeowners’ Association
- H. LID – Low Impact Development
- I. RCP – Reinforced Concrete Pipe
- J. SWC – South Weber City
- K. UAC – Utah Administrative Code
- L. UDEQ – Utah Department of Environmental Quality
- M. UDOT – Utah Department of Transportation
- N. UPDES – Utah Pollutant Discharge Elimination System
- O. USACE – United States Army Corps of Engineers

**1.05 Modification Process**

- A. Whenever, in the opinion of the City Public Works Department, the City Engineer, or the Superintendent having jurisdiction, a literal enforcement of these regulations may work an undue hardship or a literal enforcement of the provisions may be unnecessary to meet the goals and standards of the City, the City may modify those standards in the following manner:
- B. Modifications may be granted when there are practical difficulties involving carrying out the provisions of the Public Works Standards and Technical Specifications, and a panel consisting of the City Manager, City Planner, City Engineer, and the Public Works Director or their Representative determine that granting of a modification for an individual case will meet the goals and requirements of the City without unduly jeopardizing the public and the individual’s interest.
  - 1. The City shall first receive a written request for a modification to the standards from any interested party.
  - 2. Upon receipt of the request, the panel discussed above shall find that a special individual reason makes the strict letter of the standard impractical, and shall find the modification is in conformance with the intent and purpose of the standards and shall find that such modification does not in any way lessen the integrity of the standards.

3. When such findings of fact are made, the panel may grant such modification as it deems appropriate. The details of any action granted as modification by this panel shall be recorded and entered in the files of the City, with the specific reasons for the granting of said modification.

## **SECTION 2      DEVELOPMENT STANDARDS**

### **2.01    Approval Procedure**

See Title 11 – Subdivision Regulations of the South Weber City Municipal Code

### **2.02    Developer Responsibilities**

- A. Required Improvements and Guarantees – see Title 11 of South Weber City Municipal Code.
- B. Permits and Approvals
  - 1. Developer is responsible for obtaining all necessary permits and approvals for the construction of the Improvements. Copies of all applications and approved permits shall be submitted to the City. Agencies/permits that may be required include, but are not limited to:
    - a. DDW Plan Approval (pre-construction)
    - b. DDW Operating Permit (post-construction)
    - c. UPDES NOI and NOT
    - d. DWRi Stream Alteration
    - e. DWRi Dam Safety
    - f. EPA 404 Wetlands
    - g. FEMA CLOMA and/or CLOMR
    - h. UDOT
    - i. Others as applicable
- C. Improvements
  - 1. The required improvements shall include all street improvements in front of all lots along all dedicated streets to a connection with existing improvements of the same kind or to the boundary or the subdivision nearest existing improvements. Design must provide for future extension to adjacent development and to be compatible with the contour of the ground for proper drainage. All water lines, sewer lines, and any other buried conduit shall be installed to the boundary lines of the subdivision. See Municipal Code, Title 11.06 for more information.
  - 2. Upsizing based on CFPs – The Developer will be required to construct/install infrastructure sized in accordance with the City’s currently adopted CFPs. The City will be responsible for paying the difference in cost between the master planned infrastructure size and the minimum infrastructure size required for the development.
  - 3. Seal Coat – The Developer is responsible to pay for the seal coat, but the City is responsible for the timing and installation of the seal coat (See Municipal Code, Title 11.08.02-7b).

4. Street Lighting – The Developer is responsible to pay for the required street lighting, but the City is responsible for the timing and installation of the streetlights (See Municipal Code, Title 11.08.02-7c).
5. Street Signage – The Developer is responsible to pay for the required street signs. The city is responsible to order the signs. The Developer is required to install the street signs. (See Municipal Code, Title 11.08.02-7d).
6. Materials and Construction Testing – Developer shall be responsible for all materials and construction testing. Testing must be performed by a properly licensed and qualified testing agency. The results shall be provided to the City’s inspector.
7. Survey of New Improvements – Developer shall reimburse City for time spent by the City Engineer to update the city’s GIS database with the new improvements. This is done through field data collection and entering the data into the city’s database.

**2.03 Subdivision Standards**

- A. The general standards for subdivision layout and development are found in Title 11 – Subdivision Regulations.
- B. See also Section 3 – Design Standards and Section 4 – Construction Standards of this document.

**2.04 Geotechnical Investigation**

- A. A geotechnical investigation should be conducted for the following:
  1. All new residential subdivisions;
    - a. Exception: The restrictions and requirements of a Subdivision Review Cycle do not apply to the review of subdivision applications affecting property within identified geological hazard areas (See Municipal Code, Title 10-14 and State Code 10-9a-604-2-2)
  2. All commercial subdivisions and sites;
  3. Any subdivision that includes public infrastructure improvements;
  4. Any development in Sensitive Lands (see Title 10-14); and
  5. Upon request of the City.
- B. The geotechnical investigation should be complete in nature, and its findings shall be summarized in a Geotechnical Report. The Geotechnical Report shall be signed and sealed by a licensed Professional Engineer with expertise in the field of geotechnical engineering.
- C. See Appendix B for requirements regarding the Geotechnical Report, including minimum testing requirements and design parameters.

## SECTION 3 DESIGN STANDARDS

### 3.01 Plat Requirements

All plats shall contain, at a minimum the information as shown on Sheet DEV1 in the Drawings and the following specific to the Review Cycle in the approval process.

#### A. Preliminary Plat (See Municipal Code, 11.04)

1. The information on the preliminary plat shall include, at a minimum:
  - a. Name of Subdivision, True North Arrow, Basis Thereof, and Date
  - b. Township, range, section, and quarter section as applicable.
  - c. Names of the Owner(s) of record, the Surveyor of the Subdivision, and the Owner of the land immediately adjoining the land to be subdivided.
  - d. Boundary Description with the acreage carried to three (3) decimal places and the square footage rounded to the nearest whole number.
  - e. The number and square footage of each lot rounded to the nearest whole number.
  - f. Graphic scale with bar.
  - g. Ties to a minimum of two (2) section corners with bearings and distances.
  - h. Street layout with centerlines and widths dimensioned.
  - i. Phasing delineated.
  - j. Easements plotted with widths shown.
  - k. Open Space shown, if applicable.

#### B. Final Plat (See Municipal Code, 11.05)

1. The information on the final plat shall include, at a minimum:
  - a. Same information required on the Preliminary Plat.
  - b. Survey monuments.
  - c. Signature blocks for:
    1. The Owner(s) dedication
    2. The City Planner
    3. The City Engineer
    4. The Mayor
    5. The City Recorder (attesting the Mayor's signature)
    6. The City Attorney

7. Easement Approval from utility provider(s)
  - d. Prepared, and certification made as to its accuracy by a registered Land Surveyor licensed to do such work in the State of Utah.
  - e. Parcels not contiguous shall not be included in one (1) final plat, neither shall more than one (1) final plat be made on the same sheet. Contiguous parcels owned by different parties may be embraced in one (1) final plat, provided that all owners join in the dedication and acknowledgments.
2. Language conveying to the Community Association items as required in State Code Title 57.
3. Measurements and Dimensions
  - a. Scale: One inch (1") equals one hundred feet (100') or larger.
  - b. Lengths shall be shown to hundredths of a foot.
  - c. Angles and bearings shall be shown to seconds of arc.
  - d. For all curves, sufficient data shall be given to enable the re-establishment of the curves on the ground. The curve data shall include the radius, central angle, tangent, and arc length.
  - e. Bearings and dimensions shall be given for all lot lines, except that bearings and lengths need not be given for interior lot lines where the bearings and lengths are the same as those of both end lot lines.
  - f. The acreage of the development carried to three (3) decimal places, and the area of the lot rounded to the nearest whole number.
4. Clearly Identify
  - a. Survey monuments
    1. Surveys shall tie to a minimum of two (2) duly established section corners. Additional ties may also be required to the State grid system or other publicly recorded control system as required by the County Surveyor or County Recorder.
  - b. All public lands and streets shall be clearly identified.
  - c. Right-of-way lines of each street and the width of proposed or existing dedications.
  - d. Widths and locations of adjacent streets and other public properties within 150' of the subdivision shown with dashed lines.
  - e. Streets shall be identified by coordinate numbers, approved by the County Recorder, that conform to the City's addressing system.
  - f. All easements shall be designated as such, and dimensions given.



- g. Setback dimensions from proposed property boundaries to existing structures.
- h. Excepted and remainder parcels shall be marked, "Not included in this Subdivision."
- i. Notes and restrictions, shown as an "R" on each Lot, that includes applicable information regarding:
  - 1. Specialized development standards.
  - 2. The existence of CCR's (where applicable).
  - 3. Special utility or district requirements.
- j. Any other restrictive language or notes approved by the City to give notice to prospective buyers and others of special terms, restrictions, and conditions related to the Subdivision.

### **3.02 Required Improvements**

- A. See Municipal Code, Title 11.06 and 11.07 for information on the required improvements.
- B. See also Section 5 – Technical Specifications and Section 6 – Standard Drawings, Plans, and Details of this document for additional information.

### **3.03 Improvement Plans**

- A. Engineered drawings, including typical cross-sections and plans and/or written statements regarding the width and type of proposed streets; location, size and type of proposed water mains, sanitary sewers, or other sewage disposal facilities; storm drainage facilities; detention basins; and other proposed improvements and infrastructure.
- B. Lot layout and data tables showing the number of lots/units, buildable area for each lot, percentage of landscaping/open space, and density of units per acre.
- C. The required improvements shall include the location, width, and other dimensions of all existing or final platted streets, all street improvements in front of all lots along all dedicated streets to a connection with existing improvements of the same kind, or to the boundary or the subdivision nearest to existing improvements.
- D. The location, width and other dimensions of proposed alleys, shared driveways, easements, parks and other open spaces, with proper labeling of spaces to be dedicated to the public, or to be reserved for common use and benefit of Subdivision residents.
- E. All lands within the boundaries of the Subdivision shall be accounted for, either as lots, walkways, streets, or as remainder parcels.
- F. Indicated by solid-line contours superimposed on dashed-line contours of existing topography.

- G. The general locations of existing trees over six inches (6") in diameter measured at four and one-half feet (4.5') above the ground, and in the case of heavily wooded areas, an indication of the outline of the wooded area and location of trees which are to remain.
- H. Other important features which shall include but are not limited to, watercourses, areas within one hundred (100) year flood plain, exceptional topography such as wetlands, marshy areas, swamps, or any other flood-prone area, slopes that are 30% and greater, structures within the tract, existing sanitary sewers, storm drains, water supply mains, bridges, and other utilities within the tract, or within two hundred feet (200') thereof. Subdivision Design shall must provide for future extension to adjacent development and shall to be compatible with the contour of the ground for proper drainage. All water lines, sewer lines, and any other buried conduit shall be installed to the boundary lines of the subdivision. See Chapter 11.04 for more information.
- I. Complete and detailed, and signed and sealed (in accordance with Utah Code 58-22-602) construction plans and drawings of improvements shall be submitted to the City for the review by the City Engineer prior to receiving final plat approval and prior to commencing construction. No construction shall begin until plans have been checked and approved by the Administrative Land Use Authority.
- J. The following instructions are for the purpose of standardizing the preparation of drawings to obtain uniformity in appearance, clarity, size, and style. The plans and designs shall meet the standards defined in the specifications and drawings hereinafter outlined. The minimum information required on the drawings for improvements is as follows:
  - K. All drawings and/or prints shall be clear and legible and conform to industry standard engineering and drafting practices.
  - L. Drawings shall be legible and to a common scale when printed on 11"x17" paper.
  - M. Both plan view and centerline profile must be shown. On subdivisions along steep cross slopes, profiles for each side of the street may be required to be shown.
  - N. Plan and profiles shall indicate design and/or existing grades a minimum of 200 feet beyond the limits of the proposed project.
  - O. All wet utilities (water, sewer, storm drain, irrigation) shall be shown in plan and profiles views.
  - P. Each set of plans shall be accompanied by a separate sheet of details for special structures which are to be constructed and are not covered by the City Standards. All structures shall be designed in accordance with the minimum South Weber City Standards and approved by the City Engineer.
  - Q. Separate drawings of elements of the South Weber City Standards shall not be required to be redrawn and submitted with the construction drawings unless specific deviations from the standards are requested for approval; however, the construction drawings shall refer to the specific items of the Standards that are to be incorporated into the Work.

- R. The plan and profile construction plans shall be submitted in portable document format (“pdf”). Upon approval, the developer’s engineer shall provide the City Engineer with electronic files of the final plat and improvement plans in AutoCAD or other City Engineer approved format. A hard copy of the approved construction plans bearing the signature of the City Engineer shall be kept available at the construction site. Prior to final acceptance by the City, the developer, developer’s representative, contractor, or project engineer shall submit to the City Engineer a set of "as built" drawings for permanent City file record.

**3.04 Sanitary Sewer Design**

- A. All design shall be in accordance with Utah Administrative Code R317.
- B. Changes in pipe size shall occur in a manhole. Match 0.8 depth point of sewer lines. (R317-3-2-H)
- C. All terminating sewer mains shall end with a city standard manhole.
- D. Service lateral connection shall not be allowed in sewer manholes.
- E. All sewer shall be gravity unless otherwise approved by the City.
- F. Collection lines shall be located in public rights-of-way or private road rights-of-way. Collection lines shall not be located on private property (easements) without the express written permission from the City. If such case is granted, easement shall be a minimum width of 20’ and shall be dedicated to the City of South Weber.
- G. All sanitary sewer systems shall be public and shall connect to a public sewer line. Private sanitary sewer systems may be permitted on singularly owned property provided they discharge directly to a public sewer system and obtain the express written permission from the City.

**3.05 Water Design**

- A. All design shall be in accordance with Utah Administrative Code R309.
- B. Valves are required on all branches of tees and crosses. On unbroken lengths of water line, the maximum valve spacing is 1000-ft.
- C. At dead end lines, including temporary dead ends, provide fire hydrant at termination point.
- D. Where a water line crosses surface water, designer/engineer shall contact the DDW and the City prior to final design.
- E. All fire lines shall meet public works standards but shall remain privately owned and maintained.
- F. Fire hydrants
  - 1. Fire hydrants are to be installed in locations as required by the fire code and approved by the Fire Marshal and City Engineer, with a minimum spacing of 500-ft.
  - 2. Fire hydrants shall not be located within 10-ft of any sanitary sewer line or manhole.

**3.06 Street/Road Design**

- A. Streets shall be designed in accordance with these Standards, standard engineering practices, and AASHTO and MUTCD guidelines.
- B. Local (residential) streets shall have not less than 333' radius curves<sup>2</sup>
- C. No changes of grade in excess of 1.5% shall be permitted without a vertical curve.
- D. Sight triangles shall be shown at the request of the City Engineer.
- E. Horizontal points of curvature shall not be located closer than 150' from the center of an intersection.
- F. Intersections
  - 1. Roadway centerlines shall intersect at 90-degrees. Where a 90-degree angle is not feasible, the intersection angle may be reduced to as low as 80-degrees with the City Engineer's concurrence. In no case shall the angle be less than 80-degrees.
  - 2. Intersections shall be no closer than 500-ft to one another, as measured from centerline to centerline.
- G. Cul-de-Sacs
  - 1. Length of cul-de-sac shall not exceed 400-ft as shown in the Standard Drawings.
- H. Pavement / Pavement Section
  - 1. Developments
    - a. Pavement section shall be designed by the developer's geotechnical engineer and included in the Geotechnical Report submitted to the City. See Appendix B of this document for the Geotechnical Report Minimum Requirements, including testing requirements and design parameters.
  - 2. City Projects
    - a. Pavement section shall be included in the Project plans.
  - 3. See Appendix D, Sheet R1 for minimum pavement section and notes.
  - 4. Both Development and City Projects must meet the minimum pavement section thicknesses. Where geotechnical pavement design thicknesses exceed the standard minimums, the geotechnical pavement design thicknesses shall govern.
- I. Temporary Turnarounds
  - 1. When turnaround cannot be constructed outside of subdivision, it shall be located on a portion of the subdivision lots (as needed) with the developer placing in escrow an

---

<sup>2</sup> AASHTO A Policy on Geometric Design of Highways and Streets (2018): Table 3-13, 30mph,  $e = -2.0\%$ .

amount of money sufficient to complete the street improvements to the subdivision boundary. These funds will be used at such time the street is extended.

- J. The lot(s) on which the turnaround is constructed shall be restricted as follows:
  - 1. Platted as "R" (restricted lot).
  - 2. This lot cannot be sold or building permits issued until the road is extended beyond the subdivision boundary, complete with curb, gutter, and sidewalk.
  - 3. Drainage onto adjacent property must be by written approval (easement) of adjacent property owner.
  - 4. When a temporary turnaround is required at the end of a road where the road and the extension of the road are parts of an approved phased development, in lieu of constructing a paved temporary turnaround in accordance with the Standard Drawings:
  - 5. When extension of the road is expected to begin construction within 12 months of conditional acceptance of the road and associated temporary turnaround, Developer may construct 12-inch thick untreated base course temporary turnaround (dimensions per the Standard Plans) and place in escrow the cost of asphalt paving.
  - 6. If construction of the extension of the road has not begun within 12 months of conditional acceptance of the road and associated temporary turnaround, City may, at its discretion, utilize the monies in escrow to pave the temporary turnaround.
- K. Landscaping
  - 1. When landscaping is required to be designed/installed, refer to the Standard Drawings.
- L. UDOT
  - 1. Roadway intersections with UDOT controlled streets shall be in accordance with UDOT standards. A copy of the approved UDOT Access Permit shall be submitted to the City.
- M. Streetlights
- N. Street Signs

### **3.07 Storm Drain and Drainage Design**

- A. See Appendix A for Storm Drain and Drainage Design Standards.
- B. Low Impact Development (See Appendix A)
- C. 80<sup>th</sup> Percentile Storm Retention (See Appendix A)

## SECTION 4 CONSTRUCTION STANDARDS

### 4.01 General Policies

#### A. General Conditions

1. Permit/License: When the work is in progress, Contractor shall have at the work site a copy of the permit and his contractor's license number.
2. Private access: Temporary all-weather roadways, driveways, walks, and rights-of-way for vehicles and pedestrians shall be constructed and continuously maintained where required.
3. Street excavation in winter: Excavation of City streets during the winter months (herein defined as November 15 to April 1) will be allowed only if the work is a new service connection, required maintenance or emergency, or otherwise approved by the Public Works Department. Permanent patching of City streets excavated in the winter may be delayed until April 1 with the following provisions: Within five working days from the completion of the excavation, the permittee provides/maintains a 1-1/2" thick temporary winter asphalt surface until such time as the permanent asphalt surface is installed; the permittee shall provide/maintain a temporary untreated base course surface until such time as the temporary winter asphalt surface is installed. These provisions apply regardless of whether the permittee or City crews are performing the permanent resurfacing.
4. Existing utilities: The contractor shall use extreme caution to avoid a conflict, contact, or damage to existing utilities, such as power lines, sewer lines, storm drains, streetlights, telephone lines, cable television lines, water lines, gas lines, poles, or other appurtenances during the course of construction of this project. Any such conflict, contact, or damage shall be immediately communicated to said utility company and the Public Works Department. All projects shall be "Blue Staked" prior to construction.
5. Preconstruction pictures of existing public way improvements: The permittee may secure pictures of the conditions of the existing public way improvements such as curbing, sidewalk, landscaping, asphalt surfaces, etc. In the event that public way improvements are damaged and no pictures are taken, the Public Works Department will assume the correction of the damage is the responsibility of the permittee.

#### B. Licensing

1. Contractor (including all sub-contractors) must be licensed with the State of Utah: It is the policy of South Weber City that contractors desiring to perform work in the City's public way shall be properly licensed in the State of Utah. The acceptable licenses shall be in accordance with UAC R156-55a-301.

- a. Exceptions: A license shall not be required by the City when the permittee is a public utility company. However, subcontractors for utility companies shall have a valid contractor's license.

C. Permits

1. Developer/Contractor is responsible for obtaining all necessary permits for the construction of the Improvements prior to commencement of said Improvements. Agencies/permits required may include, but are not limited to:
  2. Encroachment (City)
    - a. South Weber City's Department of Public Works issues permits to control any excavation and construction operations in the public right-of-way. All contractors, sub-contractors, and utility companies proposing to construct, repair, or replace any facility within the public right-of-way shall contact the South Weber City Building Department and complete all permit requirements prior to commencing proposed work.
    - b. Work by utility companies and their contractors in constructing facilities in new subdivision streets shall be required to post a bond with the City and will be subject to City inspection and compliance with all requirements.
    - c. Emergency Work
      - (i) Maintenance of pipelines or facilities in the public way may proceed without a permit when emergency circumstances demand the work be done immediately provided a permit could not reasonably and practicably have been obtained beforehand.
      - (ii) In the event that emergency work is commenced on or within any public way of the City, the Public Works Department shall be notified within one-half hour when the work commences or as soon as possible from the time the work is commenced. Contact shall be made to the City's "on call" personnel. If emergency work is commenced during off business hours, the Public Works Department will be notified within one (1) hour of the start of work on the first regular business day of which City offices are open after such work commences, and, at the discretion of the Public Works Department, a permit may be issued which shall be retroactive to the date when the work was begun. Before commencing the emergency work, all necessary safety precautions for the protection of the public and the direction and control of traffic shall be taken. None of the provisions of these regulations are waived for emergency situations except for the prior permit requirement.
    - d. Enforcement: Violators of these regulations of working within the Public Way shall be subject to the provisions of the applicable South Weber City Municipal Code.
3. USACE/DWRi Stream Alteration – Stream Alteration

4. UPDES
  5. Dam Safety (DWRi)
  6. UDOT
  7. Davis County Surveyor's Monument
- D. Excavation Operations
1. Blue Stakes: Before commencing excavation operations, the permittee shall call "Blue Stakes" at 1-800-662-4111 or 811.
  2. Traffic control devices: Traffic control devices such as construction signs, barricades, and cones must be in place before excavation begins.
  3. Protection of paved surfaces outside of excavation area: In order to avoid unnecessary damage to paved surfaces, backhoes, outriggers, tracked equipment, or any other construction equipment that may prove damaging to asphalt shall use rubber cleats or paving pads when operating on or crossing said surfaces.
  4. Open trench limits: Open trenches will be limited to one block at a time or 660 feet, whichever is less.
  5. In the event of a planned road closure, Contractor shall notify the City, Fire Department, emergency services dispatch, US Postal Service, and Davis School District a minimum of 24 hours prior to the closure. In the case of an emergency, the above listed agencies will soon be notified at the soonest possible time.
- E. Environmental Controls
1. Dust and debris: The permittee or contractor shall keep dust and debris controlled at the work site at all times. If necessary, a container shall be provided for debris and dusty areas shall be wet down. The permittee or contractor shall be responsible for the cleanup of mud or debris from public roads deposited by vehicles or construction equipment exiting the work site. The City Engineer reserves the right to shut down the work or issue a citation if dust is not controlled.
  2. Noise: The permittee or contractor shall keep neighborhood free of noise nuisance in accordance with the Noise Ordinance.
  3. Cleanup: The permittee or contractor shall remove all equipment, material, barricades, and similar items from the right-of-way. Areas used for storage of excavated material will be smoothed and returned to their original contour. Vacuum sweeping or hand sweeping shall be required when the Building Department determines cleaning equipment is ineffective.
  4. Storm Water: All Contractors working within the boundaries of South Weber City shall conform to all requirements and regulations as outlined by the South Weber City Storm



Water Management Plan. Copies of the plan are available in the South Weber City Offices.

**4.02 Pre-Construction Meeting**

- A. The pre-construction meeting shall not be held until the City Engineer has approved and signed the construction plans.
- B. A preconstruction meeting shall be held before any excavation or other work is begun in the subdivision or Project. The meeting will include:
  - 1. City Engineer
  - 2. Developer or Project Manager
  - 3. Subdivision or Project Engineer
  - 4. All contractors and subcontractors involved with installing the subdivision or project improvements
  - 5. Representatives of affected South Weber City Departments
  - 6. Representatives of local utility companies as may be required by South Weber City.
- C. Items pertaining to the construction and inspection of the subdivision or Project improvements will be discussed.

**4.03 Construction**

- A. Specifications
  - 1. Contractor shall be responsible for constructing all improvements in accordance with the Technical Specifications, per Section 5 of this document.
  - 2. Deviations from such shall be reviewed and authorized by the City Engineer on a case-by-case basis.
- B. Plans and Details
  - 1. Contractor shall be responsible for constructing all improvements in accordance with the Drawings, Plans, and Details, per Section 6 of this document.
  - 2. Deviations from such shall be reviewed and authorized by the City Engineer on a case-by-case basis.
  - 3. In the event that as-built conditions of the improvements are found to be out of compliance with the approved improvement plans and tolerances contained in these Standards, it shall be the contractor's responsibility to remove those improvements and replace them with improvements that comply with the approved improvement plans, and are within the given tolerances. Adjacent improvements may also require replacement in order to bring all improvements into compliance.

C. Sequence/Timing

1. All underground utility work shall be completed prior to placement and compaction of the roadway base course. Utilities, including service lines, not installed prior to roadway construction shall be bored as approved by the Public Works Director.
2. All concrete collars shall be installed within fourteen (14) days of asphalt placement.

D. Inspection

1. All construction work involving the installation of improvements in the subdivision or project shall be subject to inspection by the City. It shall be the responsibility of the person responsible for construction to insure that inspections take place where and when required. Certain types of construction shall have continuous inspection, while others may have only periodic inspections.
2. Requests for Inspections
  - a. Requests for inspections shall be made to the Public Works Department by the person responsible for the construction.
  - b. Requests for inspection on work requiring continuous inspection shall be made three (3) working days prior to the commencing of the work.
  - c. Notice shall also be given one (1) day in advance of the starting of work requiring periodic inspection, unless specific approval is given otherwise by the City Engineer, or his duly authorized representatives.
3. Continuous Inspection
  - a. May be required on (but not limited to) the following types of work:
    - (i) Laying of street surfacing
    - (ii) Placing of concrete for curb and gutter, sidewalks, and other structures
    - (iii) Laying of sewer pipe, irrigation pipe, drainage pipe, water mains, water service laterals and testing.
    - (iv) On construction requiring continuous inspection, no work shall be done except in the presence or by permission of the City Engineer or authorized city representative.
4. Periodic inspections
  - a. Shall be required on (but not limited to) the following types of work:
    - (i) Street grading and gravel base
    - (ii) Excavations for curb and gutter and sidewalks
    - (iii) Excavations for structures
    - (iv) Trenches for laying pipe

- (v) Forms for curb and gutter, sidewalks and structures
- 5. Substantial and Final Completion Inspections
  - a. A substantial completion inspection shall be requested by the Contractor and made by the City Engineer or authorized representative after all construction work is completed. Any faulty or defective work shall be corrected by the persons responsible for the work within a period of thirty (30) days of the date of the City Engineer's or authorized representative's Punchlist defining the faulty or defective work.
  - b. A final completion inspection shall be requested by the Contractor and made by the City Engineer or authorized representative after all faulty and defective work has been corrected.
- 6. Testing
  - a. Development Projects
    - (i) Developer/Contractor shall select a properly licensed and qualified testing agency.
    - (ii) Developer/Contractor shall be responsible for coordinating all testing in accordance with the Technical Specifications per Section 5 of this document.
    - (iii) Testing reports shall be submitted to City weekly for review. Areas with failed tests shall be corrected and retested.
    - (iv) Failure to have improvements tested as they are constructed may be cause for work stoppage or rejection by City.
  - b. City Projects
    - (i) Contractor shall select a properly licensed and qualified testing agency.
    - (ii) Contractor shall be responsible for coordinating all testing in accordance with the Technical Specifications per Section 5 of this document.
    - (iii) Testing reports shall be submitted to City weekly for review. Areas with failed tests shall be corrected and retested. Contractor may be required to pay for retesting.
  - c. Failure to have improvements tested as they are constructed may be cause for work stoppage or rejected by City.
- 7. Safety
  - a. Contractor is solely responsible for jobsite safety.
  - b. Contractor shall comply with all local, state, and federal rules and regulations regarding jobsite safety.

- c. City and/or its authorized representatives shall have the authority to shut down a job when unsafe working conditions are found.

## **SECTION 5      TECHNICAL SPECIFICATIONS**

### **5.01      Technical Specifications for South Weber City**

- A. Adoption of Divisions 01 through 34 of the Manual of Standard Specifications, as published by Utah LTAP Center, Utah State University, Logan, Utah, current edition, with all published amendments.
- B. Modifications and Additions to Manual of Standard Specifications (see Appendix C)

### **5.02      Order of Precedence**

- A. Approved project-specific specifications (when applicable)
- B. Modifications and Additions to Manual of Standard Specifications
- C. Manual of Standard Specifications, current edition, with all published amendments

## **SECTION 6      STANDARD DRAWINGS, PLANS, AND DETAILS**

### **6.01      Standard Drawings, Plans, and Details for South Weber City**

- A. South Weber City Public Works Standard Drawings, current edition (See Appendix D)
- B. Adoption of Manual of Standard Plans, published by Utah LTAP Center, Utah State University, Logan, Utah, current edition, with all published amendments.

### **6.02      Order of Precedence**

- A. Approved project-specific drawings and details (when applicable)
- B. South Weber City Public Works Standard Drawings, current edition
- C. Manual of Standard Plans, current edition, with all published amendments, when not covered by one of the aforementioned items

## **APPENDIX A – STORM DRAIN AND DRAINAGE DESIGN STANDARDS**

## APPENDIX A

### STORM DRAIN AND DRAINAGE DESIGN STANDARDS

#### TABLE OF CONTENTS

A1.	General Provisions .....	1
A2.	Definitions and Acronyms .....	1
A3.	Rainfall Hydrology .....	4
A4.	Storm Drain System .....	6
A5.	Detention and Retention Basins .....	7
A6.	Water Quality .....	11
A7.	80 <sup>th</sup> Percentile Storm Retention .....	11
A8.	Low Impact Development .....	12

#### EXHIBITS

1. NOAA Point Precipitation Frequency Estimates – Intensity
2. NOAA Point Precipitation Frequency Estimates – Depth
3. Summary of Allowable LID BMPs



**A1. General Provisions**

- A. This document represents the reporting, design and construction standards for private and public design and construction as it relates to storm drainage within the City.
- B. A Storm Water Report is required for all new development and redevelopment projects.
- C. Implementation of LID measures and 80<sup>th</sup> percentile storm retention does not reduce or eliminate the requirement for detention/retention as contained in this document, but may be included within the designed detention/retention volumes calculated.

**A2. Definitions and Acronyms**

The following terms shall be defined as follows in this document related to storm water:

- A. 80<sup>th</sup> Percentile Storm – The rainfall event whose precipitation total is greater than or equal to 80 percent of all storm events over a given period of record.
- B. Best Management Practices (BMPs) – Construction practices and control measures necessary to protect against pollution generated by construction sites.
- C. Common Plan of Development – "Common plan of development or sale" means one plan for development or sale, separate parts of which are related by any announcement, piece of documentation (including a sign, public notice or hearing, sales pitch, advertisement, drawing, plat, blueprint, contract, permit application, zoning request, computer design, etc.), physical demarcation (including contracts) that identify the scope of the project. A plan may still be a common plan of development or sale even if it is taking place in separate stages or phases, is planned in combination with other construction activities, or is implemented by different owners or operators.<sup>1</sup> Common plans of development may be residential, commercial, or industrial in nature.
- D. Detention Basin – A water storage pond designed to store a volume of water that reduces the post-development peak runoff of a storm to the pre-development runoff rate or other rate as defined by the governing body. This is accomplished by the use of an outlet which controls the rate of flow out of the pond into the receiving storm drain or water body. Detention ponds contain an inlet, outlet, and spillway; the inlet and outlet may be one and the same. The detention basin is intended to drain the storm water within a period of time to make the volume available for the next storm event.
- E. Development – Any man-made change to unimproved land, including but not limited to site preparation, excavation, filling, grading, paving, and construction of buildings or other structures.

---

<sup>1</sup> General Permit for Discharges from Small Municipal Separate Storm Sewer Systems (MS4s); State of Utah Department of Environmental Quality, Division of Water Quality; May 12, 2021.

- F. Disturb – To alter the physical condition, natural terrain or vegetation of land by clearing, grubbing, grading, excavating, filling, building or other construction activity.
- G. Drain Inlet – A point of entry into a sump, storm water basin, or storm drain system.
- H. Drinking Water Source Protection Zone – Zones determined by geo-hydrology designed to protect groundwater aquifers of a well in a culinary water system.
- I. DWQ – Acronym for Division of Water Quality, a division of the UDEQ.
- J. Freeboard – The vertical distance between the emergency spillway and the top of the basin embankment.
- K. General Permit for discharges from MS4 (Permit) – Authorization for a municipal separate storm sewer system to discharge storm water into waters of the United States.
- L. Hardscape – Generally impervious areas, typically streets, sidewalks, driveways, parking areas, and roofs.
- M. Infiltration – The movement of water through the soil surface and into the soil;<sup>2</sup> the movement of water downward from the ground surface through the upper soil.<sup>3</sup>
- N. Infiltration Rate – The rate at which water actually enters the soils during a storm.<sup>2</sup>
- O. Infiltration System (storm water) – A system which is designed to return storm water runoff into an underground aquifer.
  - 1. Bioretention facilities, rain gardens, and tree boxes that are designed to slow down and hold storm water runoff for biological treatment and use by vegetative uptake are not considered to be infiltration systems if they are not isolated from groundwater. Groundwater isolation may be achieved with impermeable liners or an underdrain that does not discharge into a dug, bored, drilled or driven well, improved sinkhole or other subsurface fluid distribution system.
  - 2. The discharge of storm water piping below grade for the purpose of infiltration is considered a Class V injection well facility.
- P. Injection Well, Class V – As defined in Utah Administrative Code R317-7-2:
  - 1. A bored, drilled, or driven shaft whose depth is greater than its largest surface dimension, OR
  - 2. A dug hole whose depth is greater than its largest surface dimension, OR
  - 3. An improved sinkhole, OR
  - 4. A subsurface fluid distribution system.

---

<sup>2</sup> Linsley/Franzini/Freyberg/Tchobanglous. (1992). *Water Resources Engineering and Environmental Engineering*. New York: McGraw-Hill Inc.

<sup>3</sup> Lindeburg. (2003). *Civil Engineering Reference Manual*. Belmont, CA: Professional Publications, Inc.

- Q. Low Impact Development (LID) – An approach to land development (or re-development) that works with nature to more closely mimic pre-development hydrologic functions, reduces or minimizes the quantity of storm water runoff, and protects or improves water quality in receiving water bodies.
- R. LID Analysis and Report – A written analysis of a development or redevelopment site that (1) identifies appropriate methods to reduce storm water runoff, (2) identifies the pollutants to target for each drainage area, and (3) selects appropriate structural controls to implement on the site.
- S. Municipal Separate Storm Sewer System (MS4) – The storm water conveyance system owned by the City which includes streets, catch basins, curbs, gutters, ditches, man-made channels, or storm drains. For a full definition, see UAC 317-8.
- T. Outlet – The discharge mechanism of a detention basin, typically a pipe containing a head gate or orifice to control the release of water out of the basin.
- U. Percolation – The movement of water through the subsurface soil layers, usually continuing downward to the groundwater table,<sup>3</sup> measured by a Standard Percolation Test in units of minutes per inch.
- V. Pollutant – Chemicals, sediment, trash, disease-carrying organisms, and other contaminants picked up by storm water which is conveyed into rivers, streams, and other water bodies.
- W. Redevelopment – Alteration of a property that change the footprint of a site or building.
- X. Retention Basin – A water storage pond designed to store the runoff volume of a storm and dispose of water through percolation, infiltration, and evaporation within a period of time to make the volume available for the next storm event. A retention basin contains an inlet and spillway, but no structural outlet.
- Y. Softscape – Generally pervious areas, such as native vegetation and landscaped areas.
- Z. Spillway, Emergency – A storm drain basin feature that controls and guides storm water as it spills over the basin’s embankment.
- AA. Spillway, Internal – A storm drain basin feature that allows excess water to leave the basin through discharge piping which is set at an elevation below the emergency spillway.
- BB. Storm Drain System – The system of conveyances (including but not limited to catch basins, detention basins, retention basins, infiltration galleries, curbs, gutters, ditches, cross drains, roads, man-made channels, sumps, pipes, etc.) owned and operated by the City, which is designed and used for collecting and/or conveying storm water.
- CC. Storm Water Pollution Prevention Plan (SWPPP) – A written plan that evaluates and minimizes the impact of pollutants on storm water through the use of control measures and activities that target pollution sources. A SWPPP template can be found on the UDEQ Water Quality website.
- DD. Storm Water Report – A written analysis of a development or redevelopment site that

estimates the volume and rate of storm water runoff generated by the proposed improvements. The report details rationale and calculations for establishing the sizes of storm water piping and storage facilities in compliance with this document. This Report shall also contain the calculations for determining the 80<sup>th</sup> Percentile Storm volume and methods evaluated and selected to manage the rainfall on-site.

1. This Report may be combined with the LID Analysis and Report.
- EE. Storm Water Runoff – Precipitation that is not intercepted or otherwise captured at a site which eventually enters into natural water bodies such as rivers, streams, and lakes.
- FF. Subsurface Fluid Distribution System – An assemblage of perforated pipes, drain tiles, or other similar mechanisms intended to distribute fluids below the surface of the ground. (i.e. infiltration galleries, underground retention)
- GG. UAC – Acronym for Utah Administrative Code.
- HH. UDEQ – Acronym for Utah Department of Environmental Quality.

### **A3. Rainfall Hydrology**

- A. All storm drain systems shall be designed to carry the 100-year storm, unless otherwise stated.
- B. Storm Specifications
  1. Local storm drain piping shall be designed for the 10-year storm, where the road or other above ground conveyance will carry the difference to the 100-year storm.
  2. Storm drain piping connecting two (2) streets through private property shall be designed for the 100-yr storm.
  3. Local detention basins, including all piping into the basin from the nearest point of entry shall be designed to accommodate a 10-year storm event with a maximum discharge of 0.1 cubic feet per second (cfs).
  4. Local retention basins, including piping into the basin from the nearest point of entry, shall be designed to accommodate the 100-year 2-hour storm.
  5. Regional detention basins, including all piping into the basin from the nearest point of entry, shall be designed to accommodate the 100-year storm event.
  6. The storm duration used for the sizing of basins shall be based upon the worst-case scenario. The time of concentration shall be calculated and shown.
  7. See Exhibits 1 and 2 for rainfall data.
- C. Hydrologic Methodology
  1. Parameters

- a. Hardscape – Proposed streets and sidewalk areas plus the estimated hardscape areas (roofs, driveways, patios, walkways etc.) determined by using a recent subdivision with similarly sized lots, or calculated area as measured from approved site plan.
  - b. Softscape – The remaining area of the subdivision not hardscape.
2. Developments less than 20 acres
- a. The Rational Method may be used. A computer model may also be used. See paragraph 3 for more information.
  - b. Rainfall Intensity – When using the Rational Method, use the rainfall intensity table provided in Exhibit 1 of this document.
  - c. Runoff Coefficients – The following C-values shall be used when using the Rational Method:
    - i. Hardscape – 0.90
    - ii. Softscape (open space, landscaping) – 0.25
    - iii. Values from published sources may be used when pre-approved by the City Engineer.
3. Developments larger than 20 acres
- a. A City Engineer-approved computer model shall be used.
  - b. Rainfall Pattern and Depth – The following rainfall pattern shall be used. This pattern is based on the Farmer-Fletcher Distribution. This pattern is for a 1-inch unit storm and must be multiplied by rainfall depth for storms of other magnitudes, as provided in Exhibit 2.

**Farmer-Fletcher Distribution**

**Unit Storm**

Time (Min.)	Depth (inches)	Time (Min.)	Depth (inches)	Time (Min.)	Depth (inches)	Time (Min.)	Depth (inches)	Time (Min.)	Depth (inches)	Time (Min.)	Depth (inches)
1	0	11	0.004	21	0.033	31	0.052	41	0.012	51	0.005
2	0	12	0.005	22	0.034	32	0.045	42	0.011	52	0.005
3	0.002	13	0.008	23	0.035	33	0.04	43	0.01	53	0.004
4	0.002	14	0.009	24	0.038	34	0.035	44	0.009	54	0.004
5	0.002	15	0.009	25	0.039	35	0.03	45	0.009	55	0.004
6	0.002	16	0.013	26	0.045	36	0.022	46	0.008	56	0.003
7	0.002	17	0.017	27	0.052	37	0.02	47	0.006	57	0.003
8	0.002	18	0.02	28	0.054	38	0.018	48	0.006	58	0.002
9	0.003	19	0.024	29	0.054	39	0.016	49	0.005	59	0.002
10	0.003	20	0.029	30	0.054	40	0.014	50	0.005	60	0.001

**A4. Storm Drain System**

## A. Independent System

1. Storm waters shall not be conveyed in irrigation ditches.
2. Irrigation waters shall not be conveyed in storm drain systems.

## B. Groundwater

1. Where adverse groundwater conditions exist, the City may allow the installation of a subsurface land drain system. Laterals may be installed to each lot for clear groundwater only (surface water may be permitted only upon approval from the City Engineer). Subsurface lines shall be installed with a slope adequate for proper drainage. A backflow control device may be required at the confluence of the land drain system and storm drain system, as determined by the City Engineer.

## C. Piping

## 1. Storm Drain Lines

- a. All storm drain lines that are considered to be part of the City's storm drain system shall be reinforced concrete pipe (RCP), of appropriate class when installed in the public right-of-way.
- b. Minimum size for storm drain mains shall be 15-inch diameter.
- c. Public storm drain pipes shall not be curved.
- d. See Section A3 for sizing requirements.

## 2. Land Drain Lines

- a. All land drains shall be PVC or RCP.
- b. Minimum size for land drain mains shall be 8-inch diameter.
- c. Minimum size for land drain laterals shall be 4-inch diameter.

## 3. Pipe specifications are included in Section 5 of the Public Works Standards.

## 4. Reimbursement / Pioneering Agreements – Where determined by the City Engineer and/or the Storm Drain Capital Facilities Plan, larger drain lines shall be installed to accommodate future development. The cost to provide adequate storm drainage for a development shall be paid for by the Developer. Upsizing will be coordinated at the time of development. The cost of upsizing will be the responsibility of the City or as defined in the agreement.

## D. Access – Storm drain lines shall have cleanout boxes, inlets, or manholes installed at all changes in grade or alignment, with a maximum distance of 400 feet between accesses. Structures shall be installed in accordance with the standard specifications and Standard Drawings.

**E. Sumps**

1. Sumps are not allowed in the City's storm drain system, except as approved by the City Engineer on a case-by-case basis.
2. Sumps shall not be permitted within zones 1, 2, or 3 of any Drinking Water Source Protection Zone of any drinking water source.
3. Class V Injection Well permitting is required.

**F. Grates**

1. Grates shall be provided at all entrances/exits of the storm drain system, and on the upstream end of all culverts greater than 50-ft in length.
2. Grates shall be provided on catch basins, junction boxes, control structures, etc.
3. Bar spacing shall be designed for location, function, and safety. (Generally, bar spacing should not exceed three (3) inches.)

**A5. Detention and Retention Basins****A. When Required**

1. Storm drainage basins are required for all development; however, residential developments less than one (1) acre are not required to have detention or retention, except when determined by the City Engineer.
2. In an effort to increase the City's ability to more easily manage storm events, Regional Detention Basins shall be constructed wherever possible, as shown in the City's Storm Water Capital Facilities Plan.
3. As shown in the City's Storm Water Capital Facilities Plan, Developer may be required to participate in the construction of a new regional detention basin or the upgrading of an existing detention basin that is designated as a regional detention basin in lieu of onsite detention within the proposed development, if the development is located within a regional detention basin's drainage subbasin.

**B. Basin Property, Easement, and Access**

1. Public Basins – Public basins shall be located on a separate parcel dedicated to the City with frontage along a public roadway. The developer shall provide the City permanent access to any public basin.
2. Private Basin – Private basins serving multiple lots shall be located on a separate parcel, owned by the home-or land-owners association. Private basins serving a single lot shall be located within the lot. The City shall be provided an easement to, around, and across the basin for emergency access, operation, and/or repair for a private basin.
3. Access – Each basin shall be constructed with sufficient, all-weather, drivable access to all structures from a public street. A turnaround area shall be provided at the termination of the access road.

### C. Maintenance and Ownership

Actual ownership and responsibility shall be specifically defined in the Owner's Dedication, Certificates, Development Agreements, or by Deed.

1. Local Basins – Local basins shall be constructed by the developer. Following conditional acceptance of the construction, the operation and maintenance shall be conveyed to the City when applicable.
2. Regional Basins – Regional basins shall be owned and maintained by the City, constructed according to the criteria herein, and approved of the City Engineer.
3. Private Basins
  - a. Single Lots (Non-residential only) – When approved, private basins shall be owned and maintained by the property owner.
  - b. Multiple Lots – When approved, private basins shall be owned and maintained by the Homeowners' Association.
  - c. Access may be provided from a private street provided an access easement is granted to the City providing access to/from the basin from a public street.
  - d. For all private basins, Developer is required to enter into a Long-Term Storm Water Maintenance Agreement with the City.

### D. Basin Volume

1. All basin designs and calculations shall be included in the Storm Water Report and submitted to and reviewed by the City Engineer for approval.
2. Volume shall be measured to the internal spillway (overflow) elevation.
3. Volume in pipes, ditches, or roadside swales shall not be considered in the volume calculation for detention and retention basins.
4. Above-grade storage of water shall not be allowed in parking lots.

### E. Allowable Discharge Design

1. See Section A3.B for storm specifications.
2. Discharge shall not exceed the lesser of:
  - a. Pre-development runoff with pre-development, meaning the condition of the land prior to settlement, or
  - b. The discharge rate determined by using the standard rate of 0.1 cubic feet per second per total acre.

Show all calculations or provide spreadsheet or program file.

3. Calculations shall be based on the total acreage of the development draining to the basin.



4. Pass-through of offsite drainage through the development must be considered and will be allowed.
- F. Detention and Retention Basin Elements
1. Depth – Basins should not exceed three (3) feet in depth as determined from its lowest point to the overflow or spillway, unless otherwise approved by the City.
  2. Side slopes – Side slopes shall not be steeper than 4:1 (horizontal to vertical).
  3. Bottom Slope – The basin floor shall be designed so as to prevent the permanent ponding of water. The slope of the floor of the basin shall not be less than 1% to provide drainage of water to the outlet grate and prevent prolonged wet, soggy, or unstable soil conditions.
  4. Freeboard – At least one (1) foot of freeboard is required (berm above the high water mark).
  5. Spillways
    - a. The spillway shall be designed to carry the 200-year storm flow minus the 100-year storm flow which is handled by the outlet control structure.
    - b. Spillways shall introduce flows back into the pipe or stream downstream of the outlet control.
    - c. Spillways shall include a maintained swale and drainage easement to a safe location.
    - d. The spillway shall be designed to prevent erosion.
    - e. All spillways shall be designed to protect adjacent embankments, nearby structures, and surrounding properties.
  6. Ground Covers – The surface area of the basin shall be sodded. Use seed mixture found in the Technical Specifications. A minimum of four (4) inches of top soil must be installed prior to sod placement. A sprinkler irrigation system is also required for all grassed basins. Developer/contractor is responsible for establishing vegetation.
  7. Embankment (Fill) Construction – If a raised embankment is constructed for a basin (constructed with granular materials), it shall be provided with a minimum of 6-inches of clay cover on the inside of the berm to prevent water passage through the soil.
  8. Excavation (Cut) Construction – If the basin is constructed primarily by excavation, then it may be necessary to provide an impermeable liner and land drain system when constructed in the proximity of basements or other below grade structures as determined by a geotechnical evaluation.
  9. Multi-Use Basins – Basins may be designed as multi-use facilities when appropriate precautions are incorporated into the design. If amenities such as pavilions, playground equipment, volleyball courts, etc. are to be constructed within the water detention area of a basin, they shall be designed appropriately. Structures shall be designed for saturated soil conditions and bearing capacities are to be reduced accordingly. Restrooms shall not be located in areas of inundation. Inlet and outlet structures should be located as far as possible from all facilities. No wood chips or floatable objects may be used in the area that will be inundated.

10. Fencing – A conveniently-located access gate, appropriately sized for entrance by maintenance vehicles and equipment, shall be provided for fenced basins. Fencing should not be located at the top of the basin embankment where maintenance equipment, vehicles, and personnel need access. Fencing shall be a minimum of 6-ft tall, with material in accordance with these Public Works Standards and City Zoning Requirements.
- G. Detention Basins
1. Percolation – No reduction due to percolation for detention basins volumes shall be permitted.
  2. Outlet Control
    - a. Private detention basins may have a calculated fixed orifice plate mounted on the outlet of the basin.
    - b. Public detention basins shall have movable, screw-type head gates set at the calculated opening height with a stop block required to carry the maximum allowable discharge.
  3. Low Flow Piping – The inlet and outlet structures may be located in different areas of the basin, requiring a buried pipe to convey any base flows that enter and exit the basin. (Cross gutters and surface flows are prohibited.) The minimum pipe size and material for the low flow pipe shall be 15-inch RCP or as otherwise specified by the City Engineer.
  4. Oil/Sediment Separators
    - a. Sizing and design of oil/sediment separators shall be reviewed by the City Engineer and City Personnel prior to installation.
      - i. Manufacturer’s recommendations for sizing must be followed with calculations submitted to the City.
      - ii. Consideration must be given to frequency and ease of maintenance of the structure
      - iii. Separator should be installed upstream of detention basin and appropriately sized for such location.
    - b. Any site dealing with large parking lots or particularly dirty parking lots such as auto repair and maintenance will be required to have an oil separator
    - c. Private basins shall have contracts in place with a local sewer company to periodically clean the Separator (at least annually).
- H. Retention Basins (excludes 80<sup>th</sup> Percentile Storm Retention, See Section A7)
1. Retention basins must be specifically approved by the City Engineer.
  2. Retention basins shall not be permitted within zones 1, 2 or 3 of any Drinking Water Source Protection Zone of any drinking water source.
  3. An approved oil/sediment separator shall be installed upstream of retention basin.
  4. Retention Basin Criteria – Retention basins may be permitted if the following conditions apply:
    - a. The distance between the nearest City storm drain and the boundary of the development is greater than:

- i. For residential development: 500 feet or 50 feet times the number of lots in the entire development (whichever is greater);
      - ii. For commercial development: 20 feet times the number of parking stalls on site.
    - b. The basin is not located within a Hazardous Area (such as a steep slope ) or some other sensitive area (such as a Drinking Water Source Protection Zone).
    - c. Site is topographically incapable of draining to the City system.
    - d. Recommendation by the City Engineer.
  5. Percolation Rate for Retention Basins
    - a. A percolation test shall be performed by a licensed tester. The percolation test shall be performed at the elevation of the proposed grade of the bottom of the retention basin.
    - b. Due to degradation of soils ability to percolate over time, only 80% of the percolation rate shall be used in the calculations for the retention basins.
  6. Retention basins shall be designed to completely drain within 48 hours of the primary storm event.
- I. Subsurface Fluid Distribution Systems
1. Subsurface Fluid Distribution Systems are allowed for private basins only.
  2. See Paragraph H for requirements related to Percolation Rate for Retention Basins.
  3. A Class V injection well permit is required.
  4. An approved oil/sediment separator shall be installed upstream of subsurface fluid distribution system.
  5. Subsurface Fluid Distribution Systems are not allowed for storm water disposal if located in Zone 1 or 2 of a drinking water source. They may be allowed in Zone 3 or 4 of a drinking water source if they are equipped with appropriate pretreatment and approved by the City Engineer.
  6. Examples of Subsurface Fluid Distribution Systems include but are not limited to: ADS StormTech® systems, ACF Environmental R-Tanks® and similar; perforated pipe infiltration galleries, etc.

#### **A6. Water Quality**

- A. Long-term Best Management Practices (BMPs) shall be used to maintain, to the maximum extent practical, the quality of the water to the pre-developed condition.
- B. Construction BMPs shall be implemented per the City's Storm Water Management Plan.

#### **A7. 80<sup>th</sup> Percentile Storm Retention**

- A. All new development and redevelopment projects equal to or greater than one (1) acre, or projects that are less than one (1) acre that are part of a larger common plan of development or sale, shall be required to manage rainfall on-site, and prevent the off-site discharge of the precipitation from all rainfall events less than or equal to the 80<sup>TH</sup>

percentile rainfall event [storm]. This objective must be accomplished by the use of practices that are designed, constructed, and maintained to infiltrate, evapotranspiration, and/or harvest and reuse rainwater. If meeting this retention standard is technically infeasible, a rationale shall be provided on a case-by-case basis for the use of alternative design criteria. The project must document and quantify that infiltration, evapotranspiration, and rainwater harvesting have been used to the maximum extent technically feasible and that full employment of these controls are infeasible due to site constraints.<sup>3</sup>

- B. In South Weber City, the 80<sup>th</sup> percentile storm has been determined to be 0.43 inches of depth.
- C. The intent is to manage water as close as possible to the point at which it falls.
- D. Calculations and implementation rationale must be contained in the Storm Water Report.
- E. LID measures should be implemented to meet the 80<sup>th</sup> Percentile Storm requirements.
- F. Implementation of this retention standard does eliminate the requirement for detention/retention basins as described in Section A5, but may be included within the designed detention/retention volumes calculated.

#### **A8. Low Impact Development**

All new development and redevelopment projects equal to or greater than one (1) acre, or projects that are less than one (1) acre that are part of a larger common plan of development or sale, shall be required to evaluate Low Impact Development (LID) approaches to infiltrate, evapotranspiration, and/or harvest and use storm water from the site to protect water quality.<sup>4</sup>

- A. Structural controls may include green infrastructure practices such as:
  - 1. Rainwater harvesting (e.g. rain barrels)
  - 2. Rain gardens
  - 3. Permeable pavement or pavers (not permitted on public streets)
  - 4. Vegetated swales
  - 5. Preservation of vegetation (non-disturbance)
  - 6. Xeriscaping
  - 7. Others as approved by the City Engineer
- B. LID approaches must be evaluated and detailed in a LID Analysis and Report, which shall be submitted to and approved by the City Engineer.

---

<sup>4</sup> Adapted from General Permit for Discharges from Small Municipal Separate Storm Sewer Systems (MS4s); State of Utah Department of Environmental Quality, Division of Water Quality; May 12, 2021.

- C. If an LID approach cannot be utilized, the Applicant must document an explanation of the reasons preventing this approach and the rationale for the *chosen alternative controls* on a case by case basis for each project.<sup>3</sup>
- D. Implementation of LID measures does not eliminate the requirement for detention/retention basins as described in Section A5 but may be included within the designed detention/retention volumes calculated.

**EXHIBIT 1 – NOAA POINT PRECIPITATION FREQUENCY ESTIMATES - INTENSITY**



NOAA Atlas 14, Volume 1, Version 5  
 Location name: Ogden, Utah, USA\*  
 Latitude: 41.1331°, Longitude: -111.9381°  
 Elevation: 4511.67 ft\*\*  
 \* source: ESRI Maps  
 \*\* source: USGS



**POINT PRECIPITATION FREQUENCY ESTIMATES**

Sanja Perica, Sarah Dietz, Sarah Heim, Lillian Hiner, Kazungu Maitaria, Deborah Martin, Sandra Pavlovic, Ishani Roy, Carl Tryppaluk, Dale Unruh, Fenglin Yan, Michael Yekta, Tan Zhao, Geoffrey Bonnin, Daniel Brewer, Li-Chuan Chen, Tye Parzybok, John Yarchoan

NOAA, National Weather Service, Silver Spring, Maryland

--- Intensity ---

[PF\\_tabular](#) | [PF\\_graphical](#) | [Maps & aeriels](#)

**PF tabular**

PDS-based point precipitation frequency estimates with 90% confidence intervals (in inches/hour) <sup>1</sup>										
Duration	Average recurrence interval (years)									
	1	2	5	10	25	50	100	200	500	1000
5-min	1.73 (1.50-2.02)	2.17 (1.90-2.54)	2.95 (2.56-3.46)	3.67 (3.16-4.31)	4.84 (4.06-5.71)	5.93 (4.82-7.08)	7.21 (5.68-8.70)	8.74 (6.62-10.8)	11.2 (8.04-14.2)	13.6 (9.24-17.6)
10-min	1.31 (1.13-1.54)	1.65 (1.45-1.94)	2.25 (1.94-2.63)	2.80 (2.40-3.28)	3.68 (3.08-4.35)	4.51 (3.67-5.38)	5.48 (4.31-6.62)	6.65 (5.04-8.19)	8.54 (6.11-10.8)	10.3 (7.03-13.4)
15-min	1.08 (0.936-1.27)	1.36 (1.19-1.60)	1.86 (1.61-2.18)	2.31 (1.98-2.71)	3.04 (2.55-3.60)	3.72 (3.03-4.45)	4.53 (3.56-5.47)	5.50 (4.16-6.77)	7.06 (5.05-8.96)	8.52 (5.81-11.1)
30-min	0.730 (0.632-0.854)	0.918 (0.802-1.08)	1.25 (1.08-1.46)	1.56 (1.33-1.82)	2.05 (1.72-2.42)	2.51 (2.04-3.00)	3.05 (2.40-3.68)	3.70 (2.80-4.56)	4.75 (3.40-6.03)	5.74 (3.91-7.46)
60-min	0.452 (0.391-0.529)	0.568 (0.496-0.668)	0.773 (0.670-0.906)	0.962 (0.826-1.13)	1.27 (1.06-1.50)	1.55 (1.26-1.85)	1.89 (1.49-2.28)	2.29 (1.74-2.82)	2.94 (2.11-3.73)	3.55 (2.42-4.62)
2-hr	0.294 (0.259-0.338)	0.367 (0.324-0.422)	0.474 (0.416-0.544)	0.575 (0.499-0.663)	0.742 (0.630-0.863)	0.896 (0.742-1.05)	1.08 (0.865-1.28)	1.30 (1.00-1.57)	1.65 (1.20-2.06)	1.97 (1.37-2.53)
3-hr	0.226 (0.203-0.256)	0.279 (0.250-0.317)	0.348 (0.310-0.395)	0.414 (0.365-0.470)	0.520 (0.450-0.595)	0.619 (0.524-0.716)	0.739 (0.610-0.867)	0.881 (0.705-1.05)	1.12 (0.848-1.39)	1.33 (0.971-1.70)
6-hr	0.152 (0.139-0.168)	0.186 (0.170-0.206)	0.224 (0.204-0.248)	0.259 (0.234-0.288)	0.312 (0.278-0.348)	0.356 (0.313-0.400)	0.409 (0.353-0.466)	0.469 (0.395-0.542)	0.586 (0.477-0.702)	0.692 (0.547-0.861)
12-hr	0.097 (0.089-0.107)	0.119 (0.108-0.131)	0.143 (0.130-0.158)	0.164 (0.148-0.181)	0.196 (0.175-0.218)	0.223 (0.196-0.250)	0.251 (0.218-0.285)	0.282 (0.239-0.325)	0.332 (0.273-0.391)	0.373 (0.299-0.448)
24-hr	0.060 (0.056-0.064)	0.073 (0.068-0.079)	0.087 (0.081-0.094)	0.099 (0.092-0.107)	0.115 (0.106-0.124)	0.127 (0.118-0.137)	0.140 (0.129-0.151)	0.153 (0.140-0.165)	0.170 (0.155-0.198)	0.189 (0.165-0.227)
2-day	0.036 (0.033-0.039)	0.044 (0.041-0.047)	0.052 (0.048-0.056)	0.059 (0.055-0.064)	0.068 (0.063-0.074)	0.075 (0.070-0.081)	0.083 (0.076-0.089)	0.090 (0.082-0.097)	0.099 (0.090-0.108)	0.107 (0.096-0.116)
3-day	0.026 (0.024-0.028)	0.032 (0.030-0.035)	0.038 (0.036-0.041)	0.044 (0.041-0.047)	0.051 (0.047-0.054)	0.056 (0.052-0.060)	0.062 (0.057-0.067)	0.067 (0.062-0.073)	0.075 (0.068-0.081)	0.081 (0.073-0.088)
4-day	0.022 (0.020-0.023)	0.026 (0.025-0.028)	0.032 (0.029-0.034)	0.036 (0.033-0.039)	0.042 (0.039-0.045)	0.046 (0.043-0.050)	0.051 (0.047-0.055)	0.056 (0.051-0.061)	0.063 (0.057-0.068)	0.068 (0.061-0.074)
7-day	0.015 (0.014-0.016)	0.018 (0.017-0.020)	0.022 (0.020-0.023)	0.025 (0.023-0.026)	0.029 (0.027-0.031)	0.032 (0.029-0.034)	0.035 (0.032-0.038)	0.038 (0.035-0.041)	0.042 (0.038-0.046)	0.045 (0.041-0.050)
10-day	0.012 (0.011-0.013)	0.015 (0.014-0.016)	0.017 (0.016-0.019)	0.020 (0.018-0.021)	0.022 (0.021-0.024)	0.025 (0.023-0.026)	0.027 (0.025-0.029)	0.029 (0.026-0.031)	0.031 (0.029-0.034)	0.033 (0.030-0.036)
20-day	0.008 (0.007-0.008)	0.010 (0.009-0.010)	0.011 (0.011-0.012)	0.013 (0.012-0.014)	0.014 (0.014-0.015)	0.016 (0.015-0.017)	0.017 (0.016-0.018)	0.018 (0.017-0.019)	0.019 (0.018-0.021)	0.020 (0.019-0.022)
30-day	0.006 (0.006-0.007)	0.008 (0.007-0.008)	0.009 (0.009-0.010)	0.010 (0.010-0.011)	0.012 (0.011-0.012)	0.013 (0.012-0.013)	0.014 (0.013-0.014)	0.014 (0.013-0.015)	0.015 (0.014-0.017)	0.016 (0.015-0.017)
45-day	0.005 (0.005-0.006)	0.007 (0.006-0.007)	0.008 (0.007-0.008)	0.009 (0.008-0.009)	0.010 (0.009-0.010)	0.011 (0.010-0.011)	0.011 (0.011-0.012)	0.012 (0.011-0.013)	0.013 (0.012-0.014)	0.014 (0.013-0.015)
60-day	0.005 (0.004-0.005)	0.006 (0.005-0.006)	0.007 (0.006-0.007)	0.008 (0.007-0.008)	0.009 (0.008-0.009)	0.009 (0.009-0.010)	0.010 (0.009-0.011)	0.011 (0.010-0.011)	0.011 (0.010-0.012)	0.012 (0.011-0.013)

<sup>1</sup> Precipitation frequency (PF) estimates in this table are based on frequency analysis of partial duration series (PDS). Numbers in parenthesis are PF estimates at lower and upper bounds of the 90% confidence interval. The probability that precipitation frequency estimates (for a given duration and average recurrence interval) will be greater than the upper bound (or less than the lower bound) is 5%. Estimates at upper bounds are not checked against probable maximum precipitation (PMP) estimates and may be higher than currently valid PMP values. Please refer to NOAA Atlas 14 document for more information.

[Back to Top](#)

**PF graphical**

PDS-based intensity-duration-frequency (IDF) curves

Latitude: 41.1331°, Longitude: -111.9381°

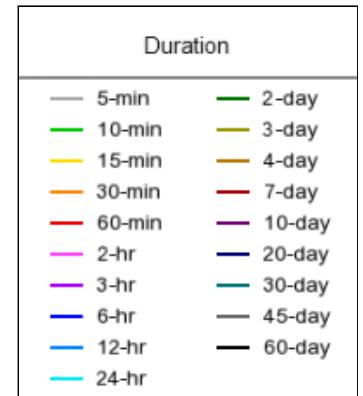
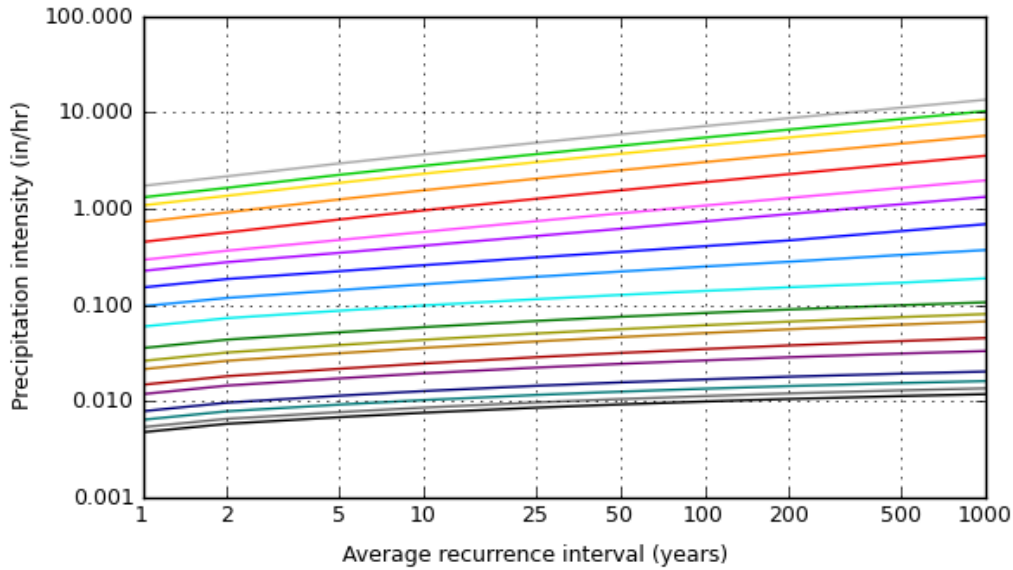
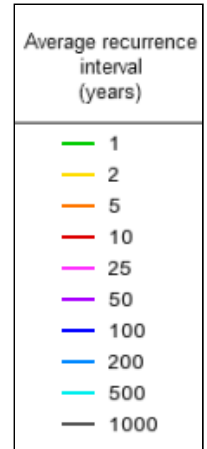
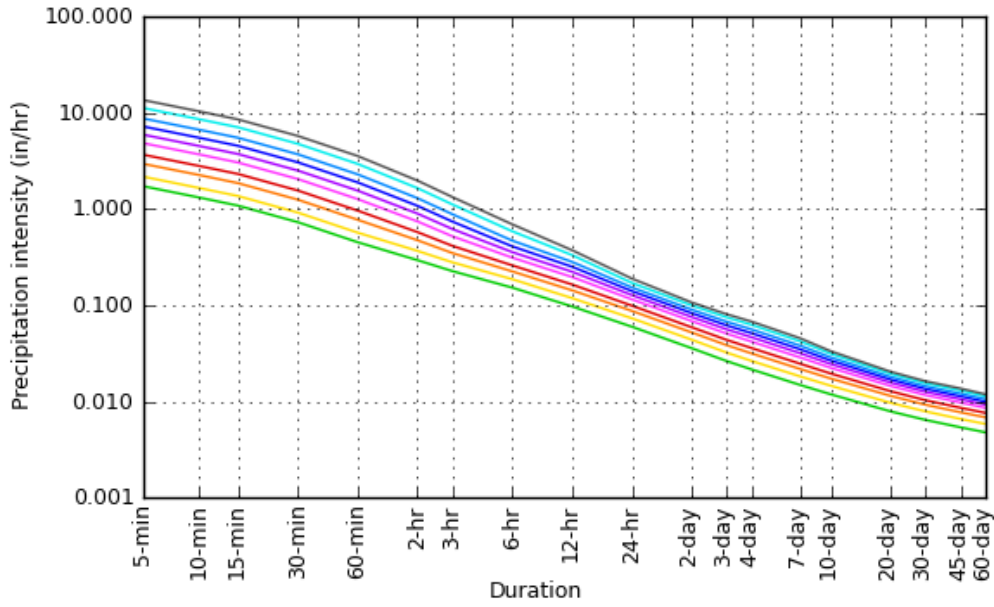

[Back to Top](#)

**Maps & aerials**

**Small scale terrain**



## **EXHIBIT 2 – NOAA POINT PRECIPITATION FREQUENCY ESTIMATES - DEPTH**



NOAA Atlas 14, Volume 1, Version 5  
 Location name: Ogden, Utah, USA\*  
 Latitude: 41.1331°, Longitude: -111.9381°  
 Elevation: 4511.67 ft\*\*



\* source: ESRI Maps  
 \*\* source: USGS

**POINT PRECIPITATION FREQUENCY ESTIMATES**

Sanja Perica, Sarah Dietz, Sarah Heim, Lillian Hiner, Kazungu Maitaria, Deborah Martin, Sandra Pavlovic, Ishani Roy, Carl Tryppaluk, Dale Unruh, Fenglin Yan, Michael Yekta, Tan Zhao, Geoffrey Bonnin, Daniel Brewer, Li-Chuan Chen, Tye Parzybok, John Yarchoan

NOAA, National Weather Service, Silver Spring, Maryland

--- Depth ---

[PF\\_tabular](#) | [PF\\_graphical](#) | [Maps & aeriels](#)

**PF tabular**

<b>PDS-based point precipitation frequency estimates with 90% confidence intervals (in inches)<sup>1</sup></b>										
Duration	Average recurrence interval (years)									
	1	2	5	10	25	50	100	200	500	1000
5-min	0.144 (0.125-0.168)	0.181 (0.158-0.212)	0.246 (0.213-0.288)	0.306 (0.263-0.359)	0.403 (0.338-0.476)	0.494 (0.402-0.590)	0.601 (0.473-0.725)	0.728 (0.552-0.897)	0.935 (0.670-1.19)	1.13 (0.770-1.47)
10-min	0.219 (0.189-0.256)	0.275 (0.241-0.323)	0.375 (0.324-0.439)	0.466 (0.400-0.546)	0.614 (0.514-0.725)	0.751 (0.611-0.897)	0.914 (0.719-1.10)	1.11 (0.840-1.37)	1.42 (1.02-1.81)	1.72 (1.17-2.24)
15-min	0.271 (0.234-0.317)	0.341 (0.298-0.401)	0.464 (0.402-0.544)	0.578 (0.496-0.677)	0.760 (0.638-0.899)	0.931 (0.758-1.11)	1.13 (0.891-1.37)	1.37 (1.04-1.69)	1.77 (1.26-2.24)	2.13 (1.45-2.77)
30-min	0.365 (0.316-0.427)	0.459 (0.401-0.540)	0.625 (0.542-0.732)	0.778 (0.667-0.912)	1.02 (0.859-1.21)	1.25 (1.02-1.50)	1.53 (1.20-1.84)	1.85 (1.40-2.28)	2.38 (1.70-3.02)	2.87 (1.96-3.73)
60-min	0.452 (0.391-0.529)	0.568 (0.496-0.668)	0.773 (0.670-0.906)	0.962 (0.826-1.13)	1.27 (1.06-1.50)	1.55 (1.26-1.85)	1.89 (1.49-2.28)	2.29 (1.74-2.82)	2.94 (2.11-3.73)	3.55 (2.42-4.62)
2-hr	0.588 (0.518-0.675)	0.734 (0.649-0.845)	0.947 (0.832-1.09)	1.15 (0.998-1.33)	1.49 (1.26-1.73)	1.79 (1.48-2.10)	2.16 (1.73-2.57)	2.59 (2.00-3.15)	3.29 (2.40-4.12)	3.94 (2.74-5.06)
3-hr	0.679 (0.609-0.768)	0.838 (0.751-0.951)	1.05 (0.930-1.19)	1.24 (1.10-1.41)	1.56 (1.35-1.79)	1.86 (1.57-2.15)	2.22 (1.83-2.61)	2.65 (2.12-3.17)	3.35 (2.55-4.16)	3.99 (2.92-5.11)
6-hr	0.912 (0.835-1.00)	1.12 (1.02-1.23)	1.34 (1.22-1.49)	1.55 (1.40-1.72)	1.87 (1.66-2.09)	2.13 (1.87-2.40)	2.45 (2.11-2.79)	2.81 (2.36-3.25)	3.51 (2.86-4.20)	4.14 (3.28-5.16)
12-hr	1.17 (1.07-1.29)	1.43 (1.31-1.57)	1.72 (1.56-1.90)	1.98 (1.79-2.18)	2.36 (2.11-2.63)	2.68 (2.37-3.01)	3.03 (2.62-3.44)	3.40 (2.88-3.91)	4.00 (3.29-4.71)	4.49 (3.60-5.40)
24-hr	1.43 (1.33-1.54)	1.75 (1.63-1.90)	2.09 (1.95-2.26)	2.37 (2.21-2.56)	2.76 (2.55-2.97)	3.06 (2.82-3.29)	3.36 (3.09-3.62)	3.67 (3.36-3.96)	4.09 (3.71-4.76)	4.54 (3.97-5.46)
2-day	1.72 (1.60-1.85)	2.10 (1.95-2.27)	2.50 (2.33-2.70)	2.83 (2.63-3.05)	3.28 (3.04-3.53)	3.62 (3.34-3.91)	3.97 (3.64-4.29)	4.32 (3.94-4.67)	4.78 (4.32-5.19)	5.12 (4.61-5.59)
3-day	1.89 (1.76-2.04)	2.32 (2.16-2.50)	2.77 (2.58-2.98)	3.14 (2.92-3.38)	3.65 (3.38-3.92)	4.04 (3.73-4.35)	4.44 (4.08-4.79)	4.85 (4.43-5.24)	5.39 (4.88-5.85)	5.80 (5.22-6.32)
4-day	2.07 (1.92-2.22)	2.53 (2.36-2.72)	3.03 (2.83-3.25)	3.44 (3.21-3.70)	4.02 (3.73-4.31)	4.46 (4.13-4.79)	4.92 (4.52-5.29)	5.38 (4.92-5.81)	6.01 (5.45-6.51)	6.49 (5.83-7.06)
7-day	2.50 (2.33-2.68)	3.06 (2.86-3.29)	3.66 (3.41-3.92)	4.15 (3.87-4.45)	4.82 (4.48-5.17)	5.34 (4.94-5.73)	5.87 (5.40-6.30)	6.39 (5.86-6.90)	7.10 (6.45-7.71)	7.64 (6.89-8.34)
10-day	2.85 (2.66-3.05)	3.50 (3.26-3.75)	4.15 (3.88-4.44)	4.68 (4.37-5.00)	5.37 (5.00-5.74)	5.88 (5.46-6.29)	6.39 (5.91-6.85)	6.89 (6.35-7.40)	7.52 (6.89-8.12)	7.99 (7.28-8.66)
20-day	3.79 (3.53-4.05)	4.65 (4.34-4.99)	5.49 (5.13-5.88)	6.13 (5.73-6.57)	6.95 (6.49-7.43)	7.54 (7.03-8.06)	8.11 (7.54-8.68)	8.65 (8.02-9.27)	9.31 (8.60-10.0)	9.78 (9.00-10.5)
30-day	4.63 (4.33-4.95)	5.68 (5.31-6.07)	6.66 (6.23-7.12)	7.42 (6.93-7.92)	8.39 (7.82-8.96)	9.08 (8.45-9.70)	9.75 (9.04-10.4)	10.4 (9.60-11.1)	11.1 (10.3-12.0)	11.7 (10.7-12.6)
45-day	5.82 (5.43-6.24)	7.11 (6.63-7.64)	8.33 (7.78-8.94)	9.29 (8.66-9.95)	10.5 (9.79-11.2)	11.4 (10.6-12.2)	12.2 (11.4-13.1)	13.0 (12.1-14.0)	14.0 (12.9-15.1)	14.7 (13.5-15.9)
60-day	6.88 (6.42-7.35)	8.41 (7.85-9.02)	9.85 (9.21-10.5)	11.0 (10.2-11.7)	12.4 (11.5-13.2)	13.4 (12.5-14.3)	14.3 (13.3-15.4)	15.2 (14.1-16.3)	16.3 (15.1-17.6)	17.1 (15.7-18.4)

<sup>1</sup> Precipitation frequency (PF) estimates in this table are based on frequency analysis of partial duration series (PDS). Numbers in parenthesis are PF estimates at lower and upper bounds of the 90% confidence interval. The probability that precipitation frequency estimates (for a given duration and average recurrence interval) will be greater than the upper bound (or less than the lower bound) is 5%. Estimates at upper bounds are not checked against probable maximum precipitation (PMP) estimates and may be higher than currently valid PMP values. Please refer to NOAA Atlas 14 document for more information.

[Back to Top](#)

**PF graphical**

PDS-based depth-duration-frequency (DDF) curves  
 Latitude: 41.1331°, Longitude: -111.9381°

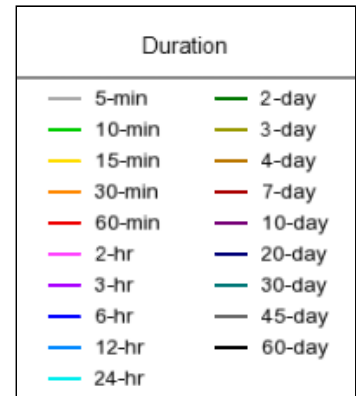
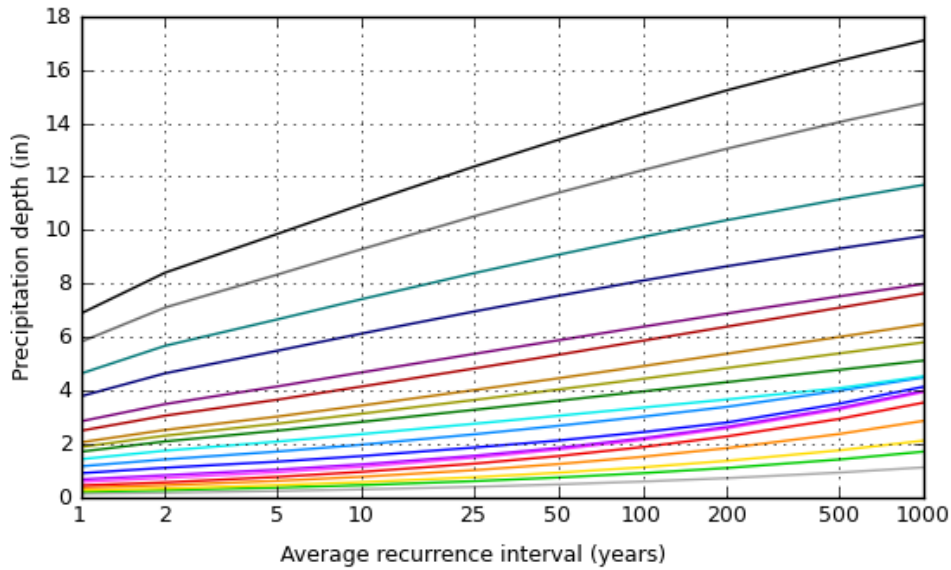
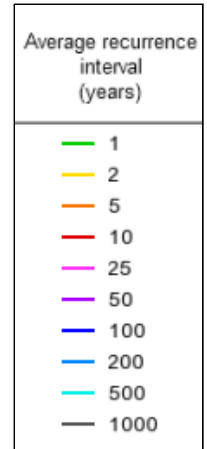
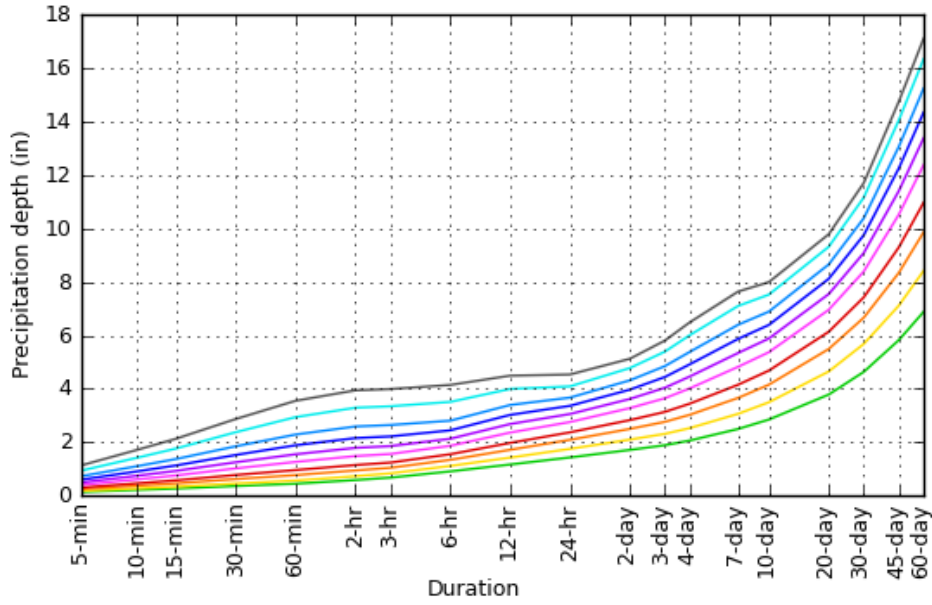

**Maps & aeriels**

Small scale terrain

## **EXHIBIT 3 – SUMMARY OF ALLOWABLE LID BMPs**

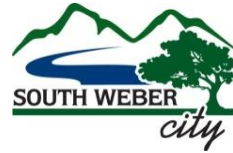

Summary of LID BMPs and Recommendations on Where to Allow  
from *A Guide to Low Impact Development within Utah*

<https://deq.utah.gov/water-quality/low-impact-development>

LID BMP Category	LID BMP Type	Fact Sheet ID	Removal Effectiveness <sup>1</sup>	Primary Functions			Maintenance Effort	Where Permitted					
				Bioretention	Volume Retention	Biofiltration		Residential - Public Roads	Residential - Private Roads	Residential - Multi-family	Commercial	Industrial	
Bioretention	Rain Garden	BR-1	high	yes	yes	yes	low-med	no	yes	yes	yes	yes	yes
	Bioretention Cell	BR-2	high	yes	yes	yes	low-med	yes	yes	yes	yes	yes	yes
	Bioswale	BR-3	medium	yes	some	yes	low	yes	yes	yes	yes	yes	yes
	Vegetated Strip	BR-4	med-high	yes	some	yes	low	yes	yes	yes	yes	yes	yes
	Tree Box Filter	BR-5	med-high	yes	varies	yes	medium	no	yes	yes	yes	yes	yes
	Green Roof	BR-6	med-high	yes	yes	yes	med-high	no <sup>2</sup>	no <sup>2</sup>	no <sup>2</sup>	yes	yes	yes
Pervious Surfaces	Pervious Surfaces	PS-1	high	yes	yes	some	low-med	no <sup>2</sup>	no <sup>2</sup>	yes	yes	yes	yes
Infiltration Devices <sup>5</sup>	Infiltration Basin <sup>3</sup>	ID-1	high	yes	yes	yes	low	yes	yes	yes	yes	yes	yes
	Infiltration Trench	ID-2	high	yes	yes	some	low	yes	yes	yes	yes	yes	no
	Dry Well <sup>3,4</sup>	ID-3	high	yes	yes	no	low-med	no	yes	yes	yes	yes	no
	Underground Infiltration Gallery <sup>3,4</sup>	ID-4	high	yes	yes	no	low-med	no	yes	yes	yes	yes	yes
Harvest and Reuse	Harvest and Reuse <sup>6</sup>	HR-1	varies	varies	yes	varies	low	no <sup>2</sup>	no <sup>2</sup>	no <sup>2</sup>	yes	yes	yes

Notes

<sup>1</sup> Sediment, Nutrients, Metals, Bacteria, Oil/Grease

<sup>2</sup> Individual homes may utilize BMP, but it will not count towards LID and retention requirement for development.

<sup>3</sup> Requires pre-treatment

<sup>4</sup> Requires UIC Class V injection well permit from State of Utah

<sup>5</sup> Other factors (e.g. drinking water source protection zone, contaminated groundwater, etc.) may limit use.

<sup>6</sup> Requires registration with DWRi

## **APPENDIX B – GEOTECHNICAL INVESTIGATION REPORT MINIMUM REQUIREMENTS**

## APPENDIX B

### GEOTECHNICAL INVESTIGATION REPORT MINIMUM REQUIREMENTS

#### B1. General Provisions

- A. All reports shall include the Minimum Testing Requirements and use the Design Parameters as detailed below.
- B. All reports shall be signed and sealed by a registered Professional Engineer licensed in Utah.

#### B2. Report Contents

- A. Geotechnical Investigation Report submitted to South Weber City shall generally include the following contents, as applicable.

##### CONTENTS

- 1.0 *Project Description/Overview*
  - 1.1 *Existing Conditions*
  - 1.2 *Proposed Improvements*
- 2.0 *Site Conditions*
  - 2.1 *Surface Conditions*
  - 2.2 *Subsurface Conditions*
  - 2.3 *Groundwater*
- 3.0 *Subsurface Investigation*
  - 3.1 *Percolation Test*
  - 3.2 *Infiltration Test*
- 4.0 *Laboratory Testing*
- 5.0 *Geologic Hazards*
  - 5.1 *Rock Fall*
  - 5.2 *Faulting*
  - 5.3 *Seismic/Ground Motions*
  - 5.4 *Lateral Spread*
  - 5.5 *Liquefaction Potential*
  - 5.6 *Landslide and Scarps*
  - 5.7 *Debris Flow/Alluvial Fan*
  - 5.8 *Expansive/Collapsible Soils*
  - 5.9 *Avalanche*
- 6.0 *Earthwork*
  - 6.1 *Site Preparation and Grading*
  - 6.2 *Temporary Excavations*
  - 6.3 *Permanent Cut and Fill Slopes*
  - 6.4 *Fill Material Composition, Placement, and Compaction*
  - 6.5 *Roadway and Embankments Fill*
  - 6.6 *Structural Fill*

- 6.7 *Utility Trenches*
  - 6.8 *Re-use of Excavated Soil Materials*
  - 7.0 *Foundations*
    - 7.1 *Foundation Recommendations*
    - 7.2 *Installation Requirements*
    - 7.3 *Estimated Settlement*
    - 7.4 *Lateral Resistance*
  - 8.0 *Static and Seismic Lateral Earth Pressures (Active, Moderately Yielding, At-Rest, and Passive Conditions)*
  - 9.0 *Floor Slabs*
  - 10.0 *Drainage Recommendations*
    - 10.1 *Surface*
    - 10.2 *Subsurface*
    - 10.3 *Foundation Drains/Subdrains*
  - 11.0 *Pavement Section*
    - 11.1 *(See Section B4)*
    - 11.2 *Exterior Concrete Flatwork*
  - 12.0 *Retaining Walls (Required for all retaining walls taller than 4 feet, when used)*
    - 12.1 *Surface and Subsurface Drainage*
    - 12.2 *Internal and Global Stability (Static and Seismic Loading)*
    - 12.3 *Dimensions and Elevations*
    - 12.4 *Settlements*
    - 12.5 *Construction Inspection*
  - 13.0 *Slope Stability (Required for slopes greater than 25%)*
  - 14.0 *References*
- Tables*
- Figures*
- A. *Project Location/Site Map*
  - B. *Boring/Test Pit Locations*
  - C. *Boring/Test Pit Logs*
  - D. *Key to Symbols for Boring/Test Pit Logs*
- Appendices, as needed*

### **B3. Minimum Testing Requirements**

- A. Borings (B) and Test Pits (TP), either known as a “hole”
  - 1. Total: Minimum 1 hole per 2 acres, rounded up
    - a. Example: 5.5 acre site:  $5.5 \div 2 = 2.75$ , round up to 3 holes
  - 2. Roadway: 1 hole + 1 hole per 500 lf of roadway (rounded up, along centerline alignment) (counts towards Total)
    - a. Example: 10.5 acre subdivision with 1,850 lf of roadway centerline
      - i. Roadway:  $1 + (1,850 \div 500) = 4.7$ , round up to 5 holes
      - ii. Total, minimum:  $10.5 \div 2 = 5.25$ , round up to 6 holes



- iii. Therefore, 6 total holes are required for subdivision, with 5 of the holes being along the roadway alignment.
3. Commercial sites: 1 hole + 1 hole per 5,000 square feet (rounded up) for buildings
  - a. Example: 13,500 sf building:  $1 + (13,500 \div 5,000) = 3.7$ , round up to 4 holes
4. Additional borings or test pits as may be required for a representative sampling of the site, as determined by the geotechnical engineer.

**B4. Minimum Design Parameters for Pavement**

- A. Local/Residential
  1. 75,000 ESALS per year
  2. 20-yr design life
  3. 3% growth factor
- B. Cul-de-Sac
  1. 50,000 ESALS per year
  2. 20-yr design life
  3. 3% growth factor
- C. Minor Collector
  1. 300,000 ESALS per year
  2. 20-yr design life
  3. 3% growth factor
- D. Major Collector / Minor Arterial
  1. Contact City for traffic requirements

## **APPENDIX C - MODIFICATIONS AND ADDITIONS TO MANUAL OF STANDARD SPECIFICATIONS**

**APPENDIX C**

**MODIFICATIONS AND ADDITIONS TO THE  
2017 MANUAL OF STANDARD SPECIFICATIONS**

as published by:  
Utah LTAP Center  
Utah State University  
Logan Utah  
2017

**TABLE OF CONTENTS**

<u>Section</u>		<u>Page No.</u>
	<b>DIVISION 03            CONCRETE</b>	
03 20 00 M	CONCRETE REINFORCING (Modified) .....	1
03 30 04 M	CONCRETE (Modified).....	2
03 30 10 M	CONCRETE PLACEMENT (Modified).....	3
	<b>DIVISION 31            EARTHWORK</b>	
31 23 16 M	EXCAVATION (Modified) .....	4
31 23 20	FILL .....	5
31 41 00 M	SHORING (Modified).....	8
	<b>DIVISION 32            EXTERIOR IMPROVEMENTS</b>	
32 01 06	STREET NAME SIGNS.....	10
32 01 13.64 M	CHIP SEAL (Modified).....	11
32 12 05 M	BITUMINOUS CONCRETE (Modified) .....	13
32 16 13 M	DRIVEWAY, SIDEWALK, CURB, GUTTER (Modified) .....	14
32 31 13 M	CHAIN LINK FENCES AND GATES (Modified) .....	15
32 31 16 M	WELDED WIRE FENCES AND GATES (Modified).....	16
32 31 23	POLY(VINYL CHLORIDE)(PVC) FENCES AND GATES.....	17
32 92 00 M	TURF AND GRASS (Modified) .....	22
	<b>DIVISION 33            UTILITIES</b>	
33 05 25 M	PAVEMENT RESTORATION (Modified).....	23
33 08 00 M	COMMISSIONING OF WATER UTILITIES (Modified).....	24
33 11 00 M	WATER DISTRIBUTION AND TRANSMISSION (Modified).....	26
33 12 16 M	WATER VALVES (Modified) .....	30
33 12 19 M	HYDRANTS (Modified) .....	32
33 12 33 M	WATER METER (Modified).....	32
33 13 00 M	DISINFECTION (Modified) .....	35

**SECTION 03 20 00 M  
CONCRETE REINFORCING (MODIFIED)**

---

**PART 3      EXECUTION**

---

**3.1      PLACING**

*Add paragraphs F and G as follows:*

- F. No steel shall extend from or be visible on any finished surface
- G. All steel shall have a minimum of 1.5-inches of concrete cover.

**SECTION 03 30 04 M  
CONCRETE (Modified)**

---

**PART 2            PRODUCTS**

---

2.4    Add paragraph F as follows:

- F.    Fiber Reinforcement: A minimum of 1.0 pounds per cubic yard of polyolefin fiber reinforcement shall be evenly distributed into the mix. Mixing shall be as recommended by the manufacturer/supplier such that the fibers do not ball up. Polyolefin fibers shall meet the requirements of ASTM C1116 and ASTM D7508.

2.5    **MIX DESIGN**

*Replace Paragraph A with the following:*

- A.    **Class:** When not specified in the plans or project specifications, use the following table to select the class of concrete required for the application:

Class	Application
5,000	Reinforced Structural Concrete
4,000	Sidewalks, curb, gutter, cross gutters, waterways, pavements, and unreinforced footings and foundations
3,000	Thrust blocks
2,000	Anchors, mass concrete

**SECTION 03 30 10 M  
CONCRETE PLACEMENT (Modified)**

---

**PART 3 EXECUTION**

---

**3.2 PREPARATION**

*Add paragraph F as follows:*

- F. No concrete shall be placed until the surfaces have been inspected and approved by the City Engineer or City Inspector.

**SECTION 31 23 16 M  
EXCAVATION (Modified)**

---

**PART 3            EXECUTION**

---

**3.3      GENERAL EXCAVATION REQUIREMENT**

*Add paragraph I as follows:*

- I.    Excavation for pipelines under existing curb and gutter, concrete slabs, or sidewalks shall be open cut. Neither tunneling nor water jetting is allowed. At the option of the City Engineer, jacking or boring under permanent facilities may be allowed based on his/her direction.



Add Section 31 23 20 Fill

**SECTION 31 23 20  
FILL**

---

**PART 1          GENERAL**

---

**1.1      SECTION INCLUDES**

- A. Non-structural fill materials.
- B. Non-structural placement and compaction.

**1.2      REFERENCES**

**A.    ASTM Standards**

- D 698      Laboratory Compaction Characteristics of Soil Using Standard Effort (12,400 ft-lbf/ft<sup>3</sup> (600 kN-m/m<sup>3</sup>)).
- D 1557     Standard Test Methods for Laboratory Compaction Characteristics of Soil Using Modified Effort (56,000 ft-lbf/ft<sup>3</sup> (2,700 kN-m/m<sup>3</sup>)).
- D 2922     Density of Soil and Soil-Aggregate in Place by Nuclear Methods (Shallow Depth).

**1.3      SUBMITTALS**

- A. When requested by ENGINEER, submit laboratory dry density and optimum laboratory moisture content for each type of fill to be used.

**1.4      QUALITY ASSURANCE**

- A. Do not change material sources without ENGINEER's knowledge.
- B. Reject material that does not comply with the requirements specified in this Section.

**1.5      STORAGE**

- A. Safely stockpile materials.
- B. Separate differing fill materials, prevent mixing, and maintain optimum moisture content of materials.

**1.6      SITE CONDITIONS**

- A. Do not place, spread, or roll any fill material over material that is damaged by water. Remove and replace damaged material at no additional cost to OWNER.
- B. Control erosion. Keep area free of trash and debris. Repair settled, eroded, and rutted areas.
- C. Reshape and compact damaged structural section to required density.

**1.7      ACCEPTANCE**

- A. General: Native material may be wasted if there is no additional cost to substitute material acceptable to ENGINEER.
- B. Lift thickness: One test per Lot.

- C. Compaction: One test per Lot. Verify density using nuclear tests, ASTM D 2922.  
Compaction and Lot sizes as follows:
  - 1. Compact to 92% Standard Proctor
  - 2. One Lot = 1500 square feet per lift

### 1.8 **WARRANTY**

- A. Repair settlement damage at no additional cost to OWNER.

---

## **PART 2 PRODUCTS**

---

### 2.1 **FILL MATERIALS**

- A. Material shall be free from sod, grass, trash, rocks larger than four (4) inches in diameter, and all other material unsuitable for construction of compacted fills.

### 2.2 **WATER**

- A. Make arrangements for sources of water during construction and make arrangements for delivery of water to site.
- B. Comply with local Laws and Regulations at no additional cost to OWNER when securing water from water utility company.

---

## **PART 3 EXECUTION**

---

### 3.1 **PREPARATION**

- A. Implement the traffic control plan requirements, Section 01 55 26.
- B. Verify material meets maximum size requirements.
- C. If ground water is in the intended fill zone, dewater.

### 3.2 **PROTECTION**

- A. Protect existing trees, shrubs, lawns, structures, fences, roads, sidewalks, paving, curb and gutter and other features.
- B. Protect above or below grade utilities. Contact utility companies to repair utility damage. Pay all cost of repairs.
- C. Avoid displacement of and damage to existing installations while compacting or operating equipment.
- D. Do not use compaction equipment adjacent to walls or retaining walls that may cause wall to become over-stressed or moved from alignment.
- E. Restore any damaged structure to its original strength and condition.

### 3.3 **LAYOUT**

- A. Identify required line, levels, contours, and datum.
- B. Stake and flag locations of underground utilities.

- C. Upon discovery of unknown utility or concealed conditions, notify ENGINEER.
- D. Maintain all benchmarks, control monuments and stakes, whether newly established by surveyor or previously existing. Protect from damage and dislocation.
- E. If discrepancy is found between Contract Documents and site, ENGINEER shall make such minor adjustments in the Work as necessary to accomplish the intent of Contract Documents without increasing the Cost of the Work to CONTRACTOR or OWNER.

#### 3.4 **SUBGRADE**

- A. Protect Subgrade from desiccation, flooding, and freezing.
- B. Before placing fill over Subgrade, get ENGINEER's inspection of subgrade surface preparations.
- C. If Subgrade is not readily compactable get ENGINEER's permission to stabilize the subgrade.

#### 3.5 **TOLERANCES**

- A. Compaction: Ninety-two (92) percent minimum relative to a standard proctor density, Section 31 23 26.
- B. Lift Thickness (before compaction):
  - 1. Eight (8) inches when using riding compaction equipment.
  - 2. Six (6) inches when using hand held compaction equipment.

#### 3.6 **CLEANING**

- A. Remove stockpiles from site. Grade site surface to prevent free standing surface water.
- B. Leave borrow areas clean and neat.

END OF SECTION

**SECTION 31 41 00 M  
SHORING (Modified)**

---

**PART 1            GENERAL**

---

**1.2     PRICE – MEASUREMENT AND PAYMENT**

A. In Trenching, Shoring:

*Revise subparagraph 1 to read as follows:*

1. A two (2) part Protective System is required if each Side of the Trench is to be shored. The use of a Trench Box shall be classified as one Protective System.

**1.4     DESIGN OF PROTECTIVE SYSTEMS**

*Add paragraphs C and D as follows:*

- C. Trenches five (5) feet deep or greater require a protective system unless the excavation is made entirely in stable rock. If less than five (5) feet deep, a competent person may determine that a protective system is not required.
- D. Trenches 20 feet deep or greater require that the protective system be designed by a registered professional engineer or be based on tabulated data prepared and/or approved by a registered professional engineer in accordance with 1926.652(b) and (c).

**1.5     SUBMITTALS**

*Revise paragraph A to read as follows:*

- A. Submit a Protective System plan:
  1. When excavation is over twenty (20) feet deep, or
  2. When requested by ENGINEER.

*Add Article 1.6 as follows:*

**1.6     REFERENCES**

- A. 29 CFR Part 1910 – Occupational Safety and Health Standards
- B. 29 CFR Part 1926 Subpart P – Excavations

---

**PART 3            EXECUTION**

---

**3.4     INSPECTIONS**

*Add paragraph C as follows:*

- C. OWNER and/or ENGINEER may order an immediate work stoppage if working conditions are thought to be unsafe. Work may resume only after proper safety precautions are implemented.

**SECTION 32 01 06 M  
STREET NAME SIGNS (Modified)**

---

**PART 1      GENERAL**

---

**1.2      REFERENCES**

*Add paragraph C as follows:*

- C.   South Weber City Public Works Standard Drawings**

**SECTION 32 01 13.64 M  
CHIP SEAL (Modified)**

---

**PART 1            GENERAL**

---

**1.2        REFERENCES****A.    ASTM Standards:**

*Add the following to paragraph A:*

- C 29            Standard Test Method for Bulk Density (“Unit Weight”) and Voids in Aggregate
- C 330          Standard Specification for Lightweight Aggregates for Structural Concrete

*Rename Article 1.5 as follows:*

**1.5        WEATHER AND CONDITIONS****D.    Temperature**

*Add subparagraph 4 as follows:*

- 4.    Do not place if forecasted temperature is expected to drop below 40 deg F within 72 hours of placement.

**B.    Moisture and Wind:**

*Add subparagraph 1 as follows:*

- 1.    Do not place chip seal coat if surface moisture is present.

---

**PART 2            PRODUCTS**

---

**2.1        ASPHALT BINDER**

*Revise paragraph B as follows:*

- A.    Emulsified Asphalt: CRS-2P or LMCRS, Section 32 12 03. Use any of the following additives to match aggregate particle charge, weather conditions, and mix design:  
(Subparagraphs 1-5 remain unchanged.)

**2.2        COVER AGGREGATE****A.    Material:**

*Revise subparagraph 2 to read as follows:*

- 2.    100% Crusher processed rotary kiln lightweight expanded shale chips (Utelite or approved equal).

Replace Table 1 with the following:

Property	ASTM	Min.	Max.
Clay Lumps and Friable Particles, percent	C142	-	2
Bulk Density Dry Loose Condition, lb/ft <sup>3</sup>	C29	-	55

B. Gradation: Analyzed on a dry weight and percent passing basis.

Replace Table 2 with the following:

Sieve	ASTM	C330 Requirement
1/2"	C136	100
3/8"		80-100
No. 4		5-40
No. 8		0-20
No 16		0-10
No. 200		0-10

Replace Article 2.3 with the following:

### 2.3 FOG SEAL/FLUSH COAT

A. Material: Use cationic emulsified asphalt grade CSS-1h, Section 32 12 03.

Add Article 2.4 as follows:

### 2.4 MIX DESIGN

- A. Select Type and grade of emulsified asphalt, ASTM D 3628.
- B. Use the following application rates, or submit mix design for approval by Engineer.
1. Emulsion: Use Table 3.

<b>Table 3 – Emulsion Application Rate</b>	
Emulsion	Application Rate (gal/sy)
CRS-2P	0.32 – 0.35
LMCRS-2	0.32 – 0.35

2. Cover Material: Use Table 4.

<b>Table 4 – Cover Material Application Rate</b>	
Emulsion	Application Rate (lbs/sy)
CRS-2P	10.0 – 12.0
LMCRS-2	10.0 – 12.0

3. Fog Seal/Flush Coat: Use 0.10 – 0.12 gal/sy at a 2:1 dilution rate.

---

## **PART 3 EXECUTION**

---

### **3.2 PREPARATION**

*Add paragraph F as follows:*

- F. Cover manholes, valves boxes, storm drain inlets, and other service utility features before placing any chip seal coat.

### **3.4 APPLICATION**

*Revise paragraph A to read as follows:*

- A. Asphalt Emulsion: Keep viscosity between 50 and 100 centistokes during application, ASTM D 2170. Keep temperature to a minimum of 145 deg F.

*Revise Article 3.6 to read as follows:*

### **3.6 FOG SEAL/FLUSH COAT**

- A. Apply asphalt seal over the chips within 24 hours of placing chips.  
 B. Keep viscosity between 50 and 100 centistokes, during application, ASTM D 2170.



**SECTION 32 12 05 M**  
**BITUMINOUS CONCRETE (MODIFIED)**  
**(Amendment 2 of the 2017 Edition APWA Specifications)**

---

**PART 1          GENERAL**

---

**1.4      SUBMITTALS**

Revise paragraph C as follows:

*Replace item 11 with the following:*

11.      Tensile Strength Ratio or Hamburg Rut Test results.

*Add the following item:*

14.      Unless otherwise specified, Road Class II shall be used for the selection of Mix Design parameters.

**SECTION 32 16 13 M**  
**DRIVEWAY, SIDEWALK, CURB, GUTTER (Modified)**

---

**PART 3            EXECUTION**

---

**3.4        CONTRACTION JOINTS**

D. Curb, Gutter, Waterway:

*Revise subparagraph 1 to read as follows:*

1. Place joints at intervals not exceeding 10 feet.

**3.5        EXPANSION JOINTS**

B. Sidewalks:

*Add subparagraph 5 as follows:*

5. Expansion joints are to be placed at 48-foot intervals (minimum) or wherever new sidewalk adjoins existing sidewalks, driveways, or aprons.

C. Curb, Gutter, Waterway:

*Add subparagraph 4 as follows:*

4. Place expansion joint where new curb and gutter adjoins existing curb and gutter.

**SECTION 32 31 13 M**  
**CHAIN LINK FENCES AND GATES (Modified)**

---

**PART 2            PRODUCTS**

---

**2.6    POSTS, CAPS, RAILS, COUPLINGS**

- A. Posts, Frames, Stiffeners, Rails: ASTM F 1043:

*Revise applicable rows of Table 1 to read as follows:*

Top Rail	1-5/8" pipe
----------	-------------

---

**PART 3            EXECUTION**

---

**3.6    INSTALLATION OF FENCE FABRIC**

*Revise paragraph A to read as follows:*

- A. Place fence fabric on roadway side of posts unless otherwise specified. Place fabric approximately 1 inch above the grounds. Maintain a straight grade between posts by excavating ground high points and filling depressions with soil.

**SECTION 32 31 16 M**  
**WELDED WIRE FENCES AND GATES (Modified)**

---

**PART 1            GENERAL**

---

**1.2      REFERENCES**

*Add paragraph D as follows:*

D. UDOT Standard Drawing

FG 2A      Right of Way Fence and Gates (Metal Post)

FG 2B      Right of Way Fence and Gates (Metal Post)

---

**PART 3            EXECUTION**

---

**3.2      INSTALLATION**

*Add paragraph N as follows:*

N. Install per UDOT Standard Drawings FG 2A and FG 2B.

*Add Section 32 31 23 Poly(Vinyl Chloride)(PVC) Fences and Gates*

**SECTION 32 31 23  
POLY(VINYL CHLORIDE)(PVC) FENCES AND GATES**

---

**PART 1            GENERAL**

---

**1.1    SECTION INCLUDES**

- A. PVC fencing, posts, gates, and appurtenances.

**1.2    REFERENCES**

A. **ASTM Standards:**

- |        |  |
|--------|--|
| D 1784 | Rigid Poly(Vinyl Chloride) (PVC) Compounds and Chlorinated Poly(Vinyl Chloride) (CPVC) Compounds |
| F 626  | Fence Fittings   |
| F 964  | Rigid Poly(Vinyl Chloride)(PVC) Exterior Profiles Used for Fencing and Railing                   |
| F 1999 | Installation of Rigid Poly(Vinyl Chloride)(PVC) Fence Systems                                    |

**1.3    SUBMITTALS**

- A. Drawings: Indicate plan layout, grid, size and spacing of components, accessories, fittings, anchorage, and post section.
- B. Data: Submit manufacturer's installation instructions and procedures, including details of fence and gate installation.
- C. Submit sample of fence fabric and typical accessories.

---

**PART 2            PRODUCTS**

---

**2.1    GENERAL**

- A. Products from other qualified manufacturers having a minimum of 5 years' experience manufacturing PVC fencing will be acceptable by the architect as equal, if approved in writing, ten days prior to bidding, and if they meet the following specifications for design, size, and fabrication. PVC Profiles, lineals, and extrusions used as components must "meet or exceed" the minimum performance guidelines laid out in ASTM 964.

**2.2    PVC FENCE**

- A. Pickets, rails, and posts fabricated from PVC extrusion. The PVC extrusions shall comply with ASTM D 1784, Class 14344B and have the following characteristics:

Specific Gravity (+/- 0.02)	1.4
Using 0.125 specimen Izod impact ft. lbs./in. notch	23.0
Tensile strength, PSI	6,910
Tensile modulus, PSI	336,000
Flexural yield strength, PSI	10,104
Flexural modulus, PSI	385,000
DTUL at 264 PSI	67°C

- B. All fence parts made from PVC shall have a minimum thickness of 0.17 in except where specified otherwise.

### 2.3 POST CAPS

- A. Molded, one piece.
- B. Cross Section: Match post or gate upright cross section.
- C. Thickness: 0.095" minimum.
- D. Configuration: Flat or four-sided as required for installation to top of posts and gate.

### 2.4 ACCESSORIES

- A. Standard gate brace, screw caps, rail end reinforcers, and other accessories as required.

### 2.5 MISCELLANEOUS MATERIALS

- A. Stiffener Chemicals: Galvanized steel structural channel. Configure channels for concealed installation within PVC rails with pre-drilled holes for drainage. Aluminum extruded channel available upon request.
1. Cross Section: 3.00" x 3.00" x 1.500" hourglass shape to grip picket.
  2. Thickness: 0.040 Gauge (minimum)
- B. Fasteners and Anchorage: Stainless Steel. All fasteners to be concealed or colored heads to match. Provide sizes as recommended by fence manufacturer.
- C. PVC Cement: As recommended by fence manufacturer.

### 2.6 GATE HARDWARE AND ACCESSORIES

- A. General: Provide hardware and accessories for each gate according to the following requirements.
- B. Hinges: Size and material to suit gate size, non-lift-off type, self-closing, glass filled nylon with stainless steel adjuster plate, offset to permit 120 degree gate opening. Provide one pair of hinges for each gate.
1. Stainless Steel, painted with carbo zinc base.
  2. Finish: Pre-painted, 2 coats "Polane."
  3. Color: Black Gravity Latch or dual access gravity latch.
- C. Latch: Manufacturers' standard self-latching, thumb latch, pre-finished steel, or stainless steel gravity latch. Provide one latch per gate.

1. Finish: Match gate hinge finish.
  - D. Hardware: Stainless Steel. Provide sizes as recommended by fence manufacturer.
    1. Finish: Match gate hinge finish.
- 2.7 **CONCRETE**
- A. Use Class 3000 concrete. Section 03 30 04.
- 2.8 **REINFORCING FOR FILLED POSTS**
- A. Steel Reinforcing:
    1. Steel Reinforcing Bars: ASTM A 615. Grade 60. Deformed (#4 or ½").
    2. Install 2 bars for each corner or gate post as specified in the drawings.

---

**PART 3 EXECUTION**

---

**3.1 PREPARATION**

- A. Locate and preserve utilities, Section 31 23 16.
- B. Excavation, Section 31 23 16.
- C. Review to ASTM F 567 and CLFMI products manual for chain link fence installation.
- D. Protect roots and branches of trees and plants to remain.
- E. Limit amount of clearing and grading along fence line to permit proper installation.

**3.2 LAYOUT OF WORK**

- A. Accurately locate and stake locations and points necessary for installation of fence and gates.
- B. General arrangements and location of fence and gates are indicated. Install except for minor changes required by unforeseen conflicts with work of other trades.

**3.3 INSTALLATION – GENERAL**

- A. Install fence in compliance with manufacturer's written instructions.
- B. PVC components shall be carefully handled and stored to avoid contact with abrasive surfaces.
- C. Install components in sequence as recommended by fence manufacturer.
- D. Install fencing as indicated on the drawings provided.
- E. Variations from the installation indicated must be approved.
- F. Variations from the fence and gate installation indicated and all costs for removal and replacement will be the responsibility of the CONTRACTOR.

**3.4 INSTALLATION OF POSTS**

- A. Excavation
  1. Drill or hand-excavate (using post hole digger) holes for posts to diameters and spacings indicated, in firm, undisturbed or compacted soil.

2. If not indicated on drawings, excavate holes for each post to a minimum diameter of 12 inches.
3. Unless otherwise indicated, excavate hole depths not less than 30 inches or to frost line.

**B. Posts**

1. Install posts in one piece, plumb and in line. Space as noted in the drawings. Enlarge excavation as required to provide clearance indicated between post and side of excavation.
2. Protect portion of posts above ground from concrete splatter. Place concrete around posts and vibrate or tamp for consolidation. Check each post for vertical and top alignment and hold in position during placement and finishing operations.
  - a. Unless otherwise indicated, terminate top of concrete footings 3 inches below adjacent grade and trowel to a crown to shed water.
  - b. Secure posts in position for manufacturer's recommendations until concrete sets.
  - c. After installation of rails and unless otherwise indicated, install reinforcing in posts in opposing corners of post as shown and fill end and gate posts with concrete to level as indicated. Concrete fill shall completely cover the reinforcing steel and gate hardware fasteners. Consolidate the concrete by striking the post face with a rubber mallet, carefully tamping around the exposed post bottom.
  - d. Install post caps. Use #8 screws, nylon washers and snap caps.
  - e. Remove concrete splatters from PVC fence materials with care to avoid scratching.

**3.5 INSTALLATION OF RAILS**

**A. Top and Bottom Rails**

1. Install rails in one piece into routed hole fabricated into posts to receive top and bottom rails, and middle where necessary. Except at sloping terrain, install rails level.
  - a. Prior to installation of rails into posts, insert concealed steel channel stiffeners in top rail, where necessary. Bottom rails shall include minimum 2- $\frac{1}{4}$ " drainage holes.
  - b. At posts to receive concrete fill, tape rail ends to prevent seepage when filling post with concrete.

**B. Middle Rails:**

1. Where necessary, install middle rails in one piece into routed hole in posts with larger holes facing down. Except at sloping terrain, install middle rails level. Secure mid rail to pickets with 2-#8 x 1- $\frac{1}{2}$ " screws evenly spaced.
  - a. At posts to receive concrete fill, tape rail ends to prevent seepage when filling post with concrete.

**3.6 INSTALLATION OF FENCE FABRIC/PICKETS**

- A. Pickets:** Install pickets in one piece as per manufacturer recommendations. Install pickets plumb.



**3.7 INSTALLATION ON SLOPING TERRAIN**

- A. At sloping terrain rails may be racked (sloped) or stepped to comply with manufacturer's recommendations.

**3.8 INSTALLATION OF GATES**

- A. Prior to installation of rails into posts, apply PVC cement into sockets per manufacturer's recommendations. Bottom rail shall include minimum 2-¼" drainage holes.
- B. Assemble gate prior to fence installation to accurately locate hinge and latch post. Align gate horizontal rails with fence horizontal rails.
- C. Install gates plumb, level, and secure for full opening without interference according to manufacturer's instructions.
- D. Gate Latch Installation. Install gate latch according to manufacturer's instructions.
- E. Allow minimum 72 hours to let concrete set-up before opening gates.

END OF SECTION

**SECTION 32 92 00 M  
TURF AND GRASS (Modified)**

---

**PART 1            GENERAL**

---

**1.3      SUBMITTALS**

*Add paragraph C as follows:*

- C. Submit seed mix if proposing alternate see mix show in paragraph 2.1.0 below.

---

**PART 2            PRODUCTS**

---

**2.1      SEED**

*Add paragraph D as follows:*

- D. Seed Mix:

<u>SEED #</u>	<u>BOTANICAL NAME</u>	<u>COMMON NAME</u>	<u>% by Weight</u>
1	Agropyron cristatum 'Fairway'	Fairway Crested Wheatgrass	15%
2	Agropyron riparium 'Sodar'	Streambank Wheatgrass	20%
3	Bromus inermis 'Manchar'	Smooth Brome	32%
4	Fescue rubra 'Fortress'	Red Fescue	25%
5	Poa compressa 'Reuben's'	Reuben's Canadian Bluegrass	6%
6	Trifolium repens	White Dutch Cover	2%

---

**PART 3            EXECUTION**

---

**3.4      SEEDING**

*Revise paragraph A to read as follows:*

- A. Apply seed at a rate of eight (8) pounds per 1,000 square feet evenly in two (2) intersecting directions. Rake in lightly.

*Add Section 33 05 12 Conductive Tracer Wire for Pipe Installation*

**SECTION 33 05 12  
CONDUCTIVE TRACER WIRE FOR PIPE INSTALLATION**

---

**PART 1            GENERAL**

---

**1.1      SUMMARY**

This section covers the requirements for installation of a conductive tracer wire with underground pipe

**1.2      SYSTEM DESCRIPTION**

Install electrically continuous tracer wire with access points as described herein to be used for locating pipe with an electronic pipe locator after installation.

---

**PART 2            PRODUCTS**

---

- 2.1      Tracer wire shall be twelve (12) gauge minimum solid copper with thermoplastic insulation recommended for direct burial. Wire connectors shall be 3M DBR, or approved equal, and shall be watertight and provide electrical continuity.

---

**PART 3            EXECUTION**

---

**3.1      ERECTION / INSTALLATION / APPLICATION AND/OR CONSTRUCTION**

A. General: Tracer wire shall be installed in the same trench and inside bored holes and casing with pipe during pipe installation. It shall be secured to the pipe as required to insure that the wire remains adjacent to the pipe. The tracer wire shall be securely bonded together at all wire joints with an approved watertight connector to provide electrical continuity, and it shall be accessible at all new water valve boxes, water meter boxes, fire hydrants, sewer manholes, and sewer cleanouts as applicable to the utility line being installed.

B. Manholes: The wire shall be installed from the exterior of the manhole to the interior by installing the wire underneath the manhole frame.

**3.2      TESTING**

CONTRACTOR shall perform a continuity test on all tracer wire in the presence of ENGINEER of ENGINEER's representative. Testing shall be performed prior to road construction.

**3.3      REPAIR / RESTORATION**

If the tracer wire is found to be not continuous after testing, CONTRACTOR shall repair or replace the failed segment of wire.

END OF SECTION

**SECTION 33 05 25 M  
PAVEMENT RESTORATION (Modified)**

---

**PART 1            GENERAL**

---

**1.2      REFERENCES**

*Replace paragraph A to read as follows:*

- A.    South Weber City Public Works Standard Drawings**

---

**PART 2            PRODUCTS**

---

**2.2      ASPHALT PAVEMENT**

*Revise paragraph A to read as follows:*

- A.    Permanent Warm Weather Asphalt Concrete: Section 32 12 05 M unless indicated otherwise.**

*Revise paragraph C to read as follows:*

- C.    Pavement Sealing:**
- 1.    Crack Seal: Section 32 01 17**
  - 2.    Chip Seal: Section 32 01 13.64 and 32 01 13.64 M.**
  - 3.    Fog Seal: Section 32 01 13.50.**

---

**PART 3            EXECUTION**

---

**3.5      ASPHALT PAVEMENT RESTORATION**

*Revise paragraphs A and B to read as follows:*

- A.    Follow South Weber City Public Works Standard Drawings.**
- B.    Match existing pavement thickness or 4-inches minimum, whichever is greater.**

**SECTION 33 08 00 M**  
**COMMISSIONING OF WATER UTILITIES (Modified)**

---

**PART 3            EXECUTION**

---

**3.5        INFILTRATION TEST**

*Revise paragraph A to read as follows:*

- A. General: 150 gallons per inch diameter per mile per day. If the ground water table is less than two (2) feet above the crown of the pipe, the infiltration test is not required.

*Revise Article 3.6 in its entirety to read as follows:*

**3.6        EXFILTRATION TEST**

A. Non-Pressurized System:

- 1. General: Air test or hydrostatic test is CONTRACTOR's choice.
- 2. Air Test:
  - a. Plastic Pipe: ASTM F 1417.
    - (i) For pipe up to 30 inches diameter, pressure drop is 0.5 psi.
    - (ii) For pipe larger than 30 inches diameter, isolated joint test is 3.5 psi maximum pressure drop is 1.0 psi in 5 seconds.
  - b. Concrete Pipe:
    - (i) ASTM C 1214 for concrete pipe 4" to 24" diameter.
    - (ii) ASTM C 1103 for concrete pipe 27" and larger.
- 3. Hydrostatic Test: Provide air release taps at pipeline's highest elevations and expel all air before the test. Insert permanent plugs after test has been completed.
  - a. Plastic Pipe: ASTM F 2497.
  - b. Concrete Pipe: ASTM C 497. Abide by Section 3 and Section 16 in the ASTM standard and applicable recommendations of manufacturer.

B. Pressurized System:

- 1. Pressure Test: All newly laid pipe segments and their valves, unless otherwise specified, shall be subjected to a hydrostatic pressure test of 225 psi or 50 psi above working pressure, whichever is higher. The hydrostatic pressure test shall be conducted after the pipe segments have been partially backfilled.
- 2. Duration of Pressure Test: The duration of each hydrostatic pressure test shall be at least two (2) hours.
- 3. Test Procedure: Each pipe segment shall be slowly filled with water and the specified test pressure, measured at the point of lowest elevation, shall be applied by means of a pump connected to the pipe in a satisfactory manner. Testing against closed valves will be allowed. The pump, pipe connection, and all necessary apparatus including gauges

and meters shall be furnished by the CONTRACTOR. CONTRACTOR shall provide all labor and equipment necessary to perform the test.

4. Expelling Air Before Test: Before applying the specified test pressure, all air shall be expelled from the pipe. To accomplish this, air release mechanisms shall be installed, if necessary, at points of highest elevation, and afterwards tightly capped.
5. Examination Under Pressure: All pipes, fittings, valves, hydrants, joints, and other hardware will be subject to examination under pressure during the hydrostatic test. Any defective pipes, fittings, hydrants, valves, or other hardware discovered in consequence of this pressure test shall be removed and replaced by the CONTRACTOR with sound material, at no expense to the OWNER, and the test shall be repeated until the ENGINEER is satisfied.
6. No piping installation will be acceptable until the leakage is less than the amount allowed by industry standards for the type of pipe material being tested. Or, if no standard prevails, than the number of gallons per hour is determined by the formula:

$$Q = \frac{LD\sqrt{P}}{148,000}$$

Where: Q = allowable leakage, gallons per hour  
L = length of pipe under test, feet  
D = diameter of pipe, inches  
P = average test pressure, psig

**SECTION 33 11 00 M**  
**WATER DISTRIBUTION AND TRANSMISSION (Modified)**

---

**PART 1            GENERAL**

---

**1.2        REFERENCES**

*Revise paragraph B to read as follows:*

**B.    South Weber City Public Works Standard Drawings**

*Add to paragraph C. AWWA Standards:*

C105	Polyethylene Encasement for Ductile Iron Pipe Systems
C110	Ductile-Iron and Gray-Iron Fittings
C111	Rubber-Gasket Joints for Ductile-Iron Pressure Pipe and Fittings
C223	Fabricated Steel and Stainless Steel Tapping Sleeves
M14	AWWA Recommended Practice for Backflow Prevention and Cross-Connection Control

*Add paragraph F and G as follows:*

**F.    ANSI/NSF Standards:**

61	Drinking Water System Components
----	----------------------------------

**G.    Utah Administrative Code**

R309	Drinking Water
------	----------------

**1.3        PERFORMANCE REQUIREMENTS**

*Replace paragraph A with the following:*

**A.    Depth of Cover:**

1. Minimum as indicated on the drawings. If minimum cannot be achieved, contact ENGINEER.
2. Maximum of 72 inches unless indicated on the plans or approved by ENGINEER.

**1.5        SITE CONDITIONS**

*Revise paragraph D to read as follows:*

- D.    Do not operate any water valve until its owner and water company's permission is secured.**

---

**PART 2 PRODUCTS**

---

**2.1 PIPES AND FITTINGS**

*Revise paragraph A to read as follows:*

- A. Provide piping materials and factory fabricated piping products of sizes, types, pressure ratings, and capacities indicated. Use only NSF 61 approved products in drinking water systems. All such products shall be appropriately stamped with the NSF logo.

*Add paragraphs E and F as follows:*

- E. Mechanical Joint Fittings: Ductile iron, Class 250
- F. Flanged Fittings: Ductile iron, Class 250

**2.3 VALVE BOX**

*Revise paragraph A to read as follows:*

- A. Buried Valves in Traffic Areas: Cast iron two (2) piece slip sleeve type, 5-1/4 inch shaft, with a drop lid, rated for HL-93 loading.

*Revise paragraph C to read as follows:*

- C. Markings: Potable water main line valves box covers shall contain the wording "SOUTH WEBER WATER."

*Add Articles 2.9 and 2.10 as follows:*

**2.9 TAPPING SLEEVE AND VALVE**

- A. AWWA C223.
- B. Sleeve shall be full circumferential seat with all stainless steel tapping sleeve.
- C. Flanged outlet with flanged by MJ valve.

**2.10 FIRE SPRINKLER/SUPPRESSION LINES**

- A. Lines:
  - 1. Ductile iron, Class 51, or as approved in writing by OWNER or ENGINEER.
  - 2. Meet all specifications for main lines.
- B. Valve:
  - 1. All fire lines shall be equipped with an isolation gate valve located at the main line.



---

**PART 3 EXECUTION**

---

**3.3 LAYOUT**

*Replace paragraph B with the following:*

- B. The Utah Division of Drinking Water must grant an exception where a potable water line crosses under a sanitary sewer line.

**3.4 INSTALLATION – PIPE AND FITTING**

- A. General:

*Add subparagraphs 3 through 7 as follows:*

- 3. Encase all buried ductile iron valves, fitting, connections, and specialties in minimum 8 mil. polyethylene sheets in accordance with AWWA C105.
- 4. Waterline shall be laid and maintained to lines and grades established by the drawings, with fittings and valves at the required locations. Deviations as approved in writing by OWNER or ENGINEER.
- 5. Lay water lines on a continuous grade to avoid high points except as shown on the plans.
- 6. Cut edges and rough ends shall be ground smooth. Bevel end for push-on connections.
- 7. Do not drop pipe or fittings into trench.

*Add paragraph I as follows:*

- I. Tie-Ins:
  - 1. All tie-ins shall be made dry and not on a day proceeding a weekend or holiday.
  - 2. OWNER requires 48-hours' notice for water turn-off.
  - 3. At least 24-hours prior to a service disruption, CONTRACTOR shall notify all affected water users.
  - 4. Where shutting down a line is not feasible as determine by OWNER or ENGINEER, CONTRACTOR shall make a wet tap using a tapping sleeve and valve.

**3.5 INSTALLATION – CONCRETE THRUST BLOCK**

*Revise paragraph A to read as follows:*

- A. South Weber City Public Works Standard Drawings.

**3.8 INSTALLATION – TAPS**

*Revise paragraph A to read as follows:*

- A. South Weber City Public Works Standard Drawings.

**3.9 INSTALLATION – SERVICE LINE**

*Revise paragraph C to read as follows:*

- C. Meter Box: South Weber City Public Works Standard Drawings.

*Add paragraph D as follows:*

- D. New Water Service Line
  - 1. 1" Service
    - a. All laterals must be of one continuous copper tube between the corp stop and the meter box. No joints or copper to copper connectors are allowed.
  - 2. 1.5" and 2" Services
    - a. All solder joints shall be 95-5 solder or better, or Mueller compression fittings.

**3.10 INSTALLATION – WATERMAIN LOOP (SYPHON)**

*Revise paragraph A to read as follows:*

- A. South Weber City Public Works Standard Drawings.

**3.12 BACKFILLING**

- B. Trenches: Section 33 05 20:

*Revise subparagraphs 1 and 2 to read as follows:*

- 1. Pipe zone backfill, South Weber City Public Works Standard Drawings.
- 2. Trench backfill, South Weber City Public Works Standard Drawings.

**3.13 SURFACING RESTORATION**

- A. Roadway Trenches and Patches: Section 33 05 25:

*Revise subparagraphs 1 and 2 to read as follows:*

- 1. Asphalt concrete patch, South Weber City Public Works Standard Drawings.
- 2. Concrete pavement patch, contact OWNER for instructions.

*Add new Article 3.14 as follows:*

**3.14 FIRE SPRINKLER/SUPPRESSION LINES**

- A. Notify OWNER 48 hours prior to installation.
- B. Unless written authorization is given by OWNER, no services shall be connected to the fire sprinkler/suppression lines.
- C. Location: As approved by OWNER.

---

**SECTION 33 12 16 M**  
**WATER VALVES (Modified)**

---

**PART 1            GENERAL**

---

**1.2        REFERENCES**

*Modify the fourth (4<sup>th</sup>) item in paragraph A to read as follows:*

C509            Resilient-Seated Gate Valves for Water Supply Service

*Add paragraph B as follows:*

**B.    South Weber City Public Works Standard Drawings**

---

**PART 2            PRODUCTS**

---

**2.1        VALVES – GENERAL**

A.    Underground:

*Add subparagraph 3 as follows:*

3.    Valves over five (5) feet in depth shall have a valve nut extension stem.

**2.2        GATE VALVES**

*Add paragraph D as follows:*

D.    Model: Mueller A-2361

*Add Article 2.10 as follows:*

**2.10      AIR/VACUUM RELIEF VALVES**

- A.    Operation: Relieve air build-up and/or allow intrusion of air to prevent vacuum conditions within pipe.
- B.    Location: Valve and vent placement location as approved by OWNER or ENGINEER.
- C.    Connection: Service saddle.

---

**PART 3            EXECUTION**

---

**3.1        INSTALLATION**

*Add paragraphs D, E, and F as follows:*

- D.    Prior to installation, inspect valves for direction of opening, freedom of operation, tightness of pressure-containing bolting, and cleanliness of valve ports and seating surfaces.
- E.    Examine all valves for damage or defects immediately prior to installation.
- F.    Mark and hold defective materials for inspection by OWNER or ENGINEER. Replace rejected materials.

---

**SECTION 33 12 19 M  
HYDRANTS (Modified)**

---

**PART 1            GENERAL**

---

**1.2    REFERENCES**

*Revise paragraph A to read as follows:*

- A. **South Weber City Public Works Standard Drawings**

---

**PART 2            PRODUCTS**

---

**2.1    DRY-BARREL FIRE HYDRANT**

*Add paragraph C as follows:*

- C. Model: Mueller Super Centurion.

**2.2    VALVES**

*Revise paragraph A to read as follows:*

- C. Gate Valve: Section 33 12 16.

**2.3    ACCESSORIES**

*Revise paragraph D to read as follows:*

- D. Valve Box, Valve Chamber: Section 33 11 00.

---

**PART 3            EXECUTION**

---

**3.2    INSTALLATION**

*Revise paragraph A to read as follows:*

- C. Install hydrant according to South Weber City Public Works Standard Drawings and AWWA M17.

*Revise paragraph H to read as follows:*

- H. Install thrust block according to South Weber City Public Works Standard Drawings.

---

**SECTION 33 12 33 M**  
**WATER METER (Modified)**

---

**PART 1            GENERAL**

---

**1.2        REFERENCES**

*Add paragraph B as follows:*

- E.    South Weber City Public Works Standard Drawings.**

---

**PART 2            PRODUCTS**

---

**2.2        METERS FOR SERVICE PIPING**

*Revise paragraph A to read as follows:*

- F.    OWNER shall supply and set all 1” meters. All other meters supplied and set by CONTRACTOR.**

**2.3        SERVICE LINE, VALVES, AND FITTINGS**

*Revise paragraph A to read as follows:*

- A.    Service Pipe: Type K Copper, Section 33 05 03, with compression copper fittings made of brass.**

*Revise paragraph B to read as follows:*

- B.    Service Valves and Fittings:**
- 1.    AWWA C800.**
  - 2.    1-Inch Service Laterals – Brass corporation stops with CC thread.**
  - 3.    1.5-Inch and 2-Inch Service Laterals – Copper or brass screw-type fittings (ball valves, strainers, nipples, tees, bends, etc.).**
  - 4.    Greater than 2-Inch – Coordinate with and obtain approval from OWNER and ENGINEER.**

*Replace Article 2.4 with the following:*

**2.4        METER BOXES**

- A.    See South Weber City Public Works Standard Drawings.**

---

**PART 3            EXECUTION**

---

**3.1        INSTALLATION**

*Revise paragraph D to read as follows:*

D. OWNER Supplied Meters: Installed by OWNER unless indicated otherwise.

*Add paragraphs E and F as follows:*

- E. Install one solid piece of copper pipe from main to meter.
- F. Install service laterals with 60-inches of cover, minimum.

---

**SECTION 33 13 00 M**  
**DISINFECTION (Modified)**

---

**PART 1 GENERAL**

---

**1.2 REFERENCES**

*Modify paragraph B to read as follows:*

- B. Utah Administrative Code  
R309 Drinking Water

*Add paragraph C as follows:*

- C. NSF/ANSI Standards:  
60 Drinking Water Treatment Chemicals – Health Effects

**1.4 SUBMITTALS**

*Delete paragraphs B, C, and D in their entirety.*

*Add Article 1.8 as follows:*

**1.8 WORK PERFORMED BY OWNER**

- A. OWNER will perform bacteriological and high chlorine sampling and testing. CONTRACTOR shall provide all other work associated with this Section.

---

**PART 2 PRODUCTS**

---

**1.1 DISINFECTANT**

*Add paragraph E as follows:*

- E. All products shall comply with NSF/ANSI 60.

---

**PART 3 EXECUTION**

---

**3.1 PREPARATION**

*Add paragraphs C and D as follows:*

- C. Notify OWNER at least 72 hours prior to any flushing or disinfecting.
- D. Install temporary connections for flushing water lines after disinfection. After the satisfactory completion of the flushing work, remove and plug the temporary connection.

**3.2 DISINFECTION OF WATER LINES**

*Revise paragraph D to read as follows:*

- D. Coordinate with OWNER to collect a bacteriological water sample at end of line to be tested. If sample fails bacteriological test, flush system and retest. Continue flushing and retesting until sample passes test.

*Revise paragraph G to read as follows:*

- G. After a passing bacteriological test sample is obtained, let the system relax for 24 hours. Flush and coordinate with OWNER to collect a subsequent bacteriological sample for testing. If the subsequent test passes, then water line is acceptable.

**3.5 FIELD QUALITY CONTROL**

- A. Bacteriological Test:

*Revise subparagraphs 1 and 2 to read as follows:*

1. Coordinate with OWNER to collect samples for testing no sooner than 16 hours after system flushing.
2. OWNER will have water samples analyzed per State of Utah requirements.

*Add Article 3.6 as follows:*

**3.6 SPECIAL PROCEDURE FOR TAPPING SLEEVES**

- A. Before a tapping sleeve is installed, the exterior of the main to be tapped shall be thoroughly cleaned, and the interior surface of the sleeve shall be lightly dusted with calcium hypochlorite powder.



## **APPENDIX D – SOUTH WEBER CITY PUBLIC WORKS STANDARD DRAWINGS**

# SOUTH WEBER CITY CORPORATION

## PUBLIC WORKS STANDARD DRAWINGS

Index of Drawings (34 Sheets)

### SUBMITTED & RECOMMENDED

  
BRANDON K. JONES, P.E.  
SOUTH WEBER CITY ENGINEER



DATE 11/28/23

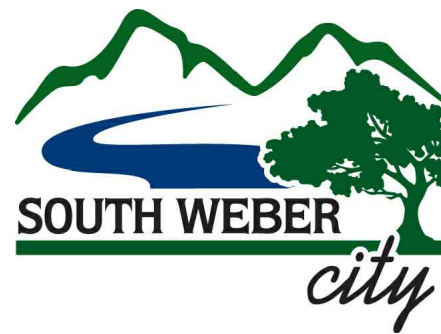

### APPROVAL

ROD WESTBROEK  
SOUTH WEBER CITY MAYOR

DATE

DAVID J. LARSON  
SOUTH WEBER CITY MANAGER

DATE

TREVOR CAHOON  
SOUTH WEBER CITY COMMUNITY & PLANNING DIRECTOR

DATE

MARK B. LARSEN  
SOUTH WEBER CITY PUBLIC WORKS DIRECTOR

DATE

LISA SMITH  
ATTEST, SOUTH WEBER CITY RECORDER

DATE

#### SPECIAL STANDARD NOTES:

A. THE CITY ADOPTS THE FOLLOWING AS STANDARDS FOR ALL ISSUES RELATED TO THE DESIGN, CONSTRUCTION, AND MAINTENANCE OF IMPROVEMENTS NOT SPECIFICALLY COVERED BY THIS MANUAL:

1. APWA: MANUAL OF STANDARD SPECIFICATIONS (CURRENT EDITION) AND ALL ADOPTED AMENDMENTS
2. APWA: MANUAL OF STANDARD PLANS (CURRENT EDITION)

B. AS TO ANY PARTICULAR ISSUE, IF A CONFLICT EXISTS BETWEEN ANY OF THE FOREGOING STANDARDS, THE CITY STANDARDS TAKE PRECEDENCE.

C. AT THE CITY'S SOLE DISCRETION, ALTERNATE METHODS OF CONSTRUCTION OR DEVIATIONS FROM THESE STANDARDS MAY BE REQUIRED OR APPROVED BY THE CITY ENGINEER AND PUBLIC WORKS DIRECTOR (OR THEIR DESIGNEE), WHEN SUCH ARE NECESSARY TO MEET THE BEST INTERESTS OF THE CITY.

#### ROAD IMPROVEMENT STANDARDS

- R1.....TYPICAL RESIDENTIAL STREET SECTION DETAILS
- R2.....SOUTH WEBER DRIVE & COLLECTOR ROADWAY TYPICAL CROSS SECTION DETAILS
- R3.....PRIVATE ROADWAY STREET CROSS SECTION DETAILS
- R4.....TYPICAL STREET INTERSECTION, UTILITY LATERAL CONFIGURATION & STREET MONUMENT DETAILS
- R5.....TYPICAL DRIVE APPROACH DETAILS
- R6.....TYPICAL ADA RAMP DETAILS
- R7.....CUL-DE-SAC & TEMPORARY TURNAROUND DETAILS
- R8.....PRIVATE ROAD CUL-DE-SAC AND HAMMERHEAD TURNAROUND DETAILS
- R9.....STREET SIGN DETAILS
- R10....TYPICAL SIDEWALK, CURB & GUTTER, CONCRETE COLLAR, AND DEFECTIVE CONC. REPLACEMENT DETAILS
- R11....UTILITY TRENCH, UTILITY POTHOLING, AND ASPHALT PATCH PLAN DETAILS
- R12....APWA PLAN 255 BITUMINOUS PAVEMENT T-PATCH

#### CULINARY WATER SYSTEM STANDARDS

- CW1....RESIDENTIAL WATER SERVICE CONNECTION DETAILS
- CW2....FIRE HYDRANT, GATE VALVE, AND AIR/VACUUM RELIEF STATION DETAILS
- CW3....TRACER WIRE INSTALLATION DETAILS
- CW4....TYPICAL WATER METER STATIONS
- CW5....PRESSURE REDUCTION STATION
- CW6....THRUST BLOCK, WATERLINE LOOP, AND MISC. VAULT DETAILS
- CW7....REDUCED PRESSURE (RP) BACKFLOW PREVENTION ASSEMBLY

#### SANITARY SEWER SYSTEM STANDARDS

- SS1....SEWER / LAND DRAIN LATERAL & MAIN LINE CONNECTION DETAILS
- SS2....SANITARY SEWER MANHOLE DETAILS

#### STORM DRAIN SYSTEM STANDARDS

- SD1....SINGLE AND DOUBLE CATCH BASIN DETAILS
- SD2....DRAINAGE INLET BOX AND GENERAL GRATE & FRAME DETAILS
- SD3....STORM DRAIN MANHOLE DETAILS
- SD4....LARGE DETENTION BASIN DETAILS
- SD5....SMALL DETENTION BASIN DETAILS

#### GENERAL CONSTRUCTION & LANDSCAPING STANDARDS

- G1.....CHAIN LINK FENCE STANDARD DETAILS
- G2.....WATER EFFICIENT LANDSCAPING

#### STREET LIGHTING STANDARDS

- SL1.....POLES AND FIXTURES
- SL2.....DEVELOPER/CONTRACTOR INSTALLATION PORTION OF STREETLIGHT STANDARDS
- SL3.....CITY CONTRACTOR INSTALLATION PORTION OF STREETLIGHT STANDARDS
- SL4.....ROCKY MOUNTAIN POWER CONNECTION DETAILS

#### LID (LOW IMPACT DEVELOPMENT) STANDARDS

- LID1....GENERAL LID (LOW IMPACT DEVELOPMENT) EXAMPLES

#### MISCELLANEOUS DEVELOPMENT STANDARDS

- DEV1....SUBDIVISION PRELIMINARY & FINAL PLAT SUBMITTALS EXAMPLE



NOVEMBER 28, 2023

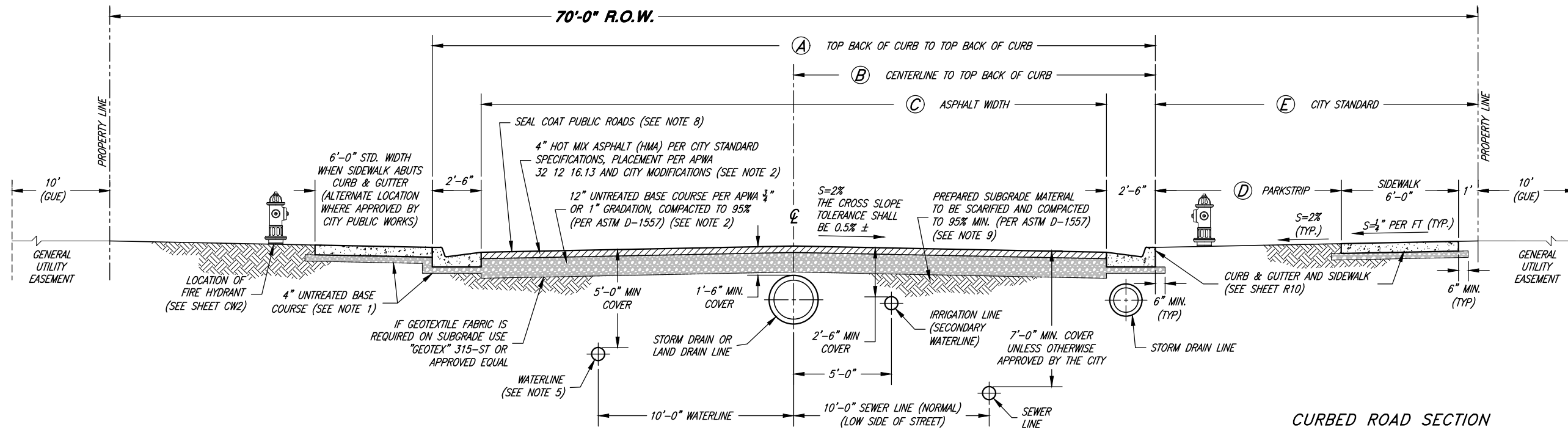

**STANDARD RESIDENTIAL STREET SECTION**

**GENERAL NOTES:**

1. PROVIDE 4" THICKNESS OF 3/4" OR 1" UNTREATED BASE COURSE UNDER SIDEWALK, DRIVEWAY APPROACHES AND CURB & GUTTER, COMPACTED TO 95%, PER ASTM D-1557.
2. THE PAVEMENT THICKNESS SHALL BE CONSIDERED AS CITY MINIMUMS AND MAY BE REQUIRED TO BE ADJUSTED WHEN A GREATER DEPTH IS NECESSARY TO PROVIDE STABILITY PER THE GEOTECHNICAL REPORT OR CITY ENGINEER. DESIGNER AND/OR DEVELOPER MAY SUBMIT AN ALTERNATIVE PAVEMENT DESIGN BASED ON A DETAILED SOILS ANALYSIS FOR APPROVAL BY THE CITY ENGINEER WHICH MAY MODIFY PAVEMENT THICKNESS, BUT IN NO CASE SHALL THE BITUMINOUS SURFACE COURSE BE LESS THAN 4" AND UNTREATED BASE COURSE LESS THAN 12" THICK.
3. ALL ROAD CUTS SHALL BE PATCHED PER SHEET R11 AND SHEET R12
4. CURB & GUTTER AND SIDEWALKS SHALL BE CONSTRUCTED USING FIBER REINFORCED CONCRETE AND IN COMPLIANCE WITH SOUTH WEBER CITY TECHNICAL SPECIFICATIONS AND THESE DRAWINGS.
5. ALL CULINARY WATER MAINS AND SERVICES MUST MAINTAIN A MINIMUM SEPARATION FROM ALL SEWER MAINS AND LATERALS OF 10'-0" HORIZONTAL AND 18" VERTICAL IN ACCORDANCE WITH THE STATE OF UTAH DIVISION OF DRINKING WATER RULES SECTION R309-550-7
6. THE 6'-0" SIDEWALK SHOWN ABOVE IS TO BE CONSIDERED THE "CITY STANDARD." OTHER LOCATIONS AND TYPES OF SIDEWALK AS REQUESTED BY THE DEVELOPER MUST BE APPROVED BY THE CITY. IF SIDEWALK IS LOCATED AGAINST THE TBC, IT MUST BE A MINIMUM OF 6 FEET IN WIDTH.
7. NATURAL GAS TYPICALLY LOCATED IN THE PARKSTRIP, POWER AND COMMUNICATION LINES TYPICALLY LOCATED BEHIND PROPERTY LINES OR IN LOT EASEMENTS.
8. "SEAL COAT" CONSISTS OF THE FOLLOWING:
  - a. CHIP SEAL PER APWA 32 01 13.64 AND CITY MODIFICATIONS, AND
  - b. FOG SEAL PER APWA 32 01 13.50.
9. IMPORTED FILL UNDER ROADWAY SHALL BE GRANULAR BORROW 2" MAX.
10. PRIOR TO THE INSTALLATION OF PAVEMENT, THE CITY INSPECTOR MUST GIVE WRITTEN PERMISSION TO PROCEED.

**GENERAL NOTES CONT.:**

11. THE SPECIAL RESIDENTIAL STREET SECTION SHALL BE USED FOR RESIDENTIAL ROADWAYS THAT QUALIFY TO BE WIDER (AS PER UTAH CODE 10-9A-508(51)). THE CITY CAN REQUIRE THE INSTALLATION OF PAVEMENT IN EXCESS OF 32 FEET FOR RESIDENTIAL ROADS THAT MEET ANY OF THE FOLLOWING CONDITIONS:
  - TO ADDRESS SPECIFIC TRAFFIC FLOW CONSTRAINTS AT AN INTERSECTION, MID-BLOCK CROSSINGS, OR OTHER AREAS;
  - TO ADDRESS AN APPLICABLE GENERAL OR MASTER PLAN IMPROVEMENT, INCLUDING TRANSPORTATION, BICYCLE LANES, TRAILS, OR OTHER SIMILAR IMPROVEMENTS THAT ARE NOT INCLUDED WITHIN AN IMPACT FEE AREA;
  - TO ADDRESS TRAFFIC FLOW CONSTRAINTS FOR SERVICE TO OR ABUTTING HIGHER DENSITY DEVELOPMENTS OR USES THAT GENERATE HIGHER TRAFFIC VOLUMES, INCLUDING COMMUNITY CENTERS, SCHOOLS, AND OTHER SIMILAR USES;
  - AS NEEDED FOR THE INSTALLATION OR LOCATION OF A UTILITY WHICH IS MAINTAINED BY THE MUNICIPALITY AND IS CONSIDERED A TRANSMISSION LINE OR REQUIRES ADDITIONAL ROADWAY WIDTH;
  - FOR THIRD-PARTY UTILITY LINES THAT HAVE AN EASEMENT PREVENTING THE INSTALLATION OF UTILITIES MAINTAINED BY THE MUNICIPALITY WITHIN THE ROADWAY;
  - FOR UTILITIES OVER 12 FEET IN DEPTH;
  - FOR ROADWAYS WITH A DESIGN SPEED THAT EXCEEDS 25 MILES PER HOUR;
  - AS NEEDED FOR FLOOD AND STORMWATER ROUTING;
  - AS NEEDED TO MEET FIRE CODE REQUIREMENTS FOR PARKING AND HYDRANTS;
  - OR AS NEEDED TO ACCOMMODATE STREET PARKING.

**CURBED ROAD SECTION**

STREET DESIGNATION	T.B.C. TO T.B.C. (A)	CENTERLINE TO T.B.C. (B)	ASPHALT WIDTH (C)	PARKSTRIP (D)	T.B.C. TO PROPERTY LINE (E)
LOCAL RESIDENTIAL	37'-0"	18'-6"	32'-0"	9'-6"	16'-6"
SPECIAL RESIDENTIAL (SEE GENERAL NOTE 11)	41'-0"	20'-6"	36'-0"	7'-6"	14'-6"

**NOTES:**

- B1. THE ROAD SECTION REQUIRED SHALL BE AS DETERMINED BY THE CITY ENGINEER BASED UPON ZONING, GENERAL PLAN, MASTER PLAN, SIZE OF DEVELOPMENT, ESTIMATED TRAFFIC VOLUME, & AMOUNT OF OPEN SPACE ASSOCIATED WITH DEVELOPMENTS, AS WELL AS THE PROXIMITY TO HIGH VOLUME ROADS OR COMMERCIAL ZONING.

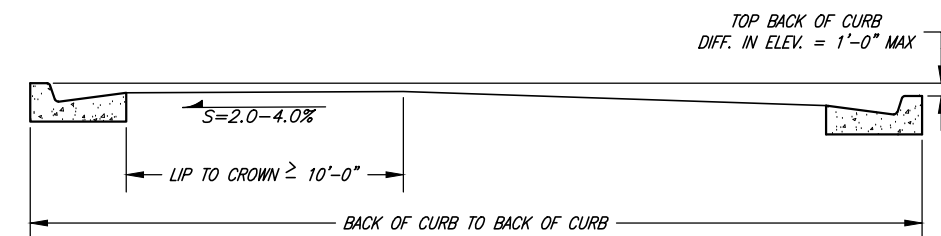

**CROWN LOCATION FOR VARIOUS CROSS SLOPES**

**CROWN NOTES:**

- A. MAXIMUM DIFFERENCE IN ELEVATION BETWEEN CURBS ON OPPOSITE SIDES OF THE STREET SHALL NOT EXCEED 1'-0" AS SHOWN IN DETAIL.
- B. ON CERTAIN STREETS APPROVED BY THE CITY COUNCIL, THE CITY ENGINEER WILL PROVIDE A PAVEMENT DESIGN. LOCATION OF SIDEWALK AND CURB & GUTTER MAY VARY PER DIRECTION OF THE CITY ENGINEER.
- C. ALL STREET CROSS SECTIONS SHALL BE AS APPROVED BY THE CITY ENGINEER.



BRANDON KENT JONES  
No. 5148758  
PROJECT ENGINEER  
11/28/2023  
DATE

REV.	DATE	APPR.

SCALE:  
N. T.S.  
DESIGNED BKJ  
DRAWN BEB  
CHECKED BKJ



**CONSULTING ENGINEERS**  
6080 Fashion Point Drive  
South Ogden, Utah 84403 (801) 476-9767  
www.jonescivil.com

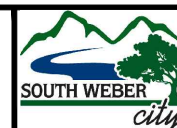

**SOUTH WEBER CITY CORPORATION**  
**PUBLIC WORKS - ROAD IMPROVEMENT STANDARDS**  
**TYPICAL RESIDENTIAL STREET SECTION DETAILS**

SHEET:  
**R1**  
OF 34 SHEETS  
0

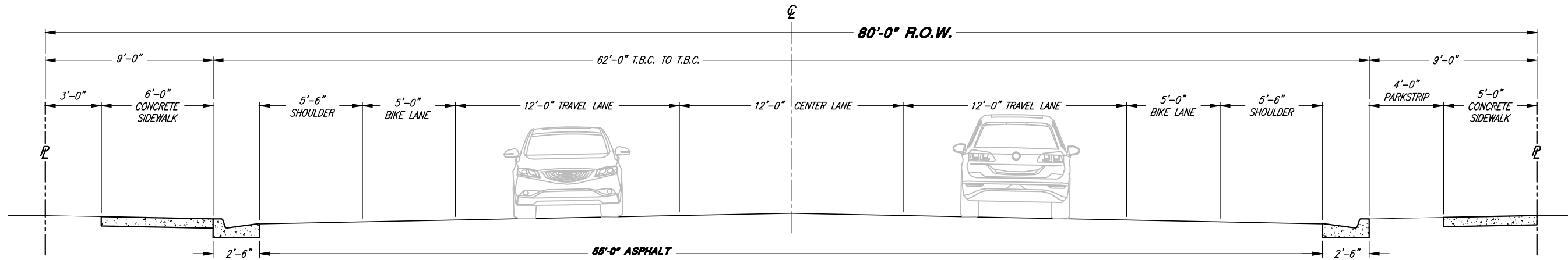

**SOUTH WEBER DRIVE R.O.W. SECTION**

THE 80'-0" ROADWAY SECTION SHOWN ABOVE IS TO BE CONSIDERED THE "CITY STANDARD" FOR SOUTH WEBER DRIVE. WHERE DESIGNATED BY THE CITY ON A CASE BY CASE BASIS IN AREAS OF PRE-EXISTING ROADWAY IMPROVEMENTS, ALTERNATE STREET CROSS SECTION DESIGNS MAY BE USED WITH PRIOR APPROVAL OF THE CITY ENGINEER AND THE CITY PUBLIC WORKS DEPARTMENT. SUBMIT ENGINEERED CONSTRUCTION PLANS TO THE CITY ENGINEER FOR REVIEW AND WRITTEN ACCEPTANCE PRIOR TO CONSTRUCTION.

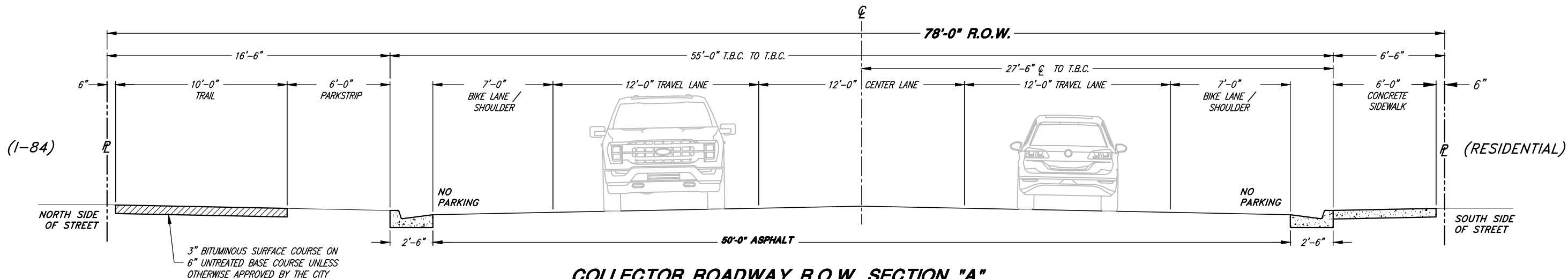

**COLLECTOR ROADWAY R.O.W. SECTION "A"**

(ADJACENT TO 1-84)

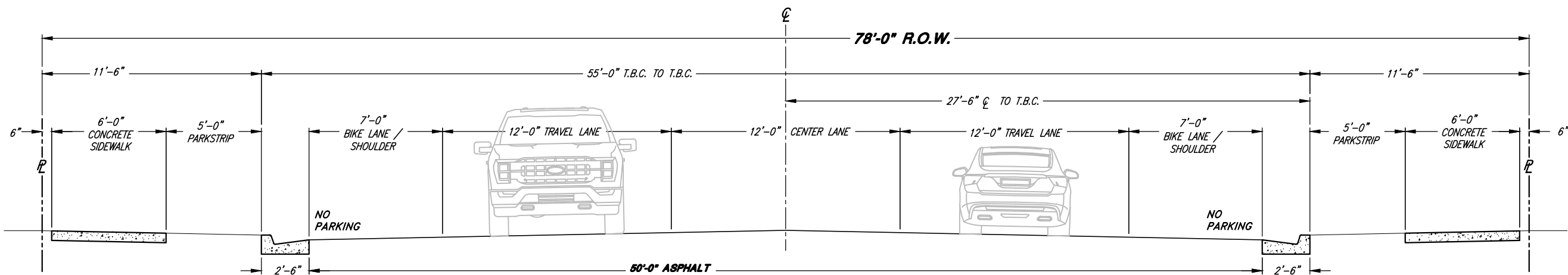

**COLLECTOR ROADWAY R.O.W. SECTION "B"**

(1-84 TO SOUTH WEBER DRIVE)



BRANDON KENT JONES  
No. 5148758  
REGISTERED PROFESSIONAL ENGINEER  
State of Utah  
PROJECT ENGINEER  
*Brandon K. Jones*  
11/28/2023  
DATE

REV.	DATE	APPR.

SCALE:  
N. T.S.  
DESIGNED BKJ  
DRAWN BEB  
CHECKED BKJ

**JA JONES & ASSOCIATES**  
CONSULTING ENGINEERS  
6080 Fashion Point Drive  
South Ogden, Utah 84403 (801) 476-9767  
www.jonescivil.com

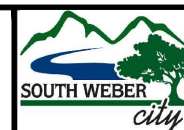

**SOUTH WEBER CITY CORPORATION**  
PUBLIC WORKS - ROAD IMPROVEMENT STANDARDS  
SOUTH WEBER DRIVE & COLLECTOR ROADWAY  
TYPICAL CROSS SECTION DETAILS

SHEET:  
**R2**  
OF 34 SHEETS  
0



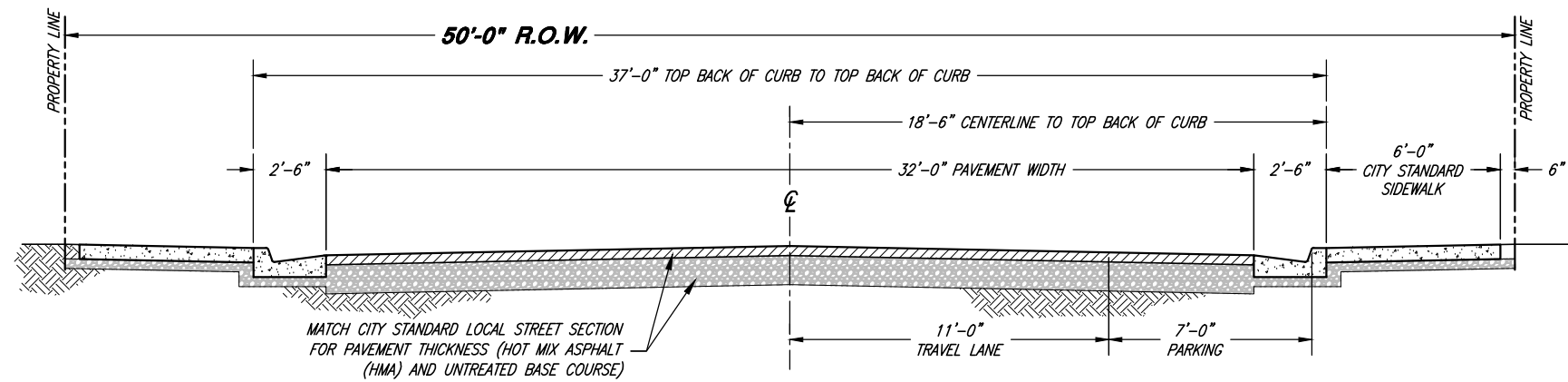

**50' RIGHT-OF-WAY  
PRIVATE ROADWAY STREET SECTION A**

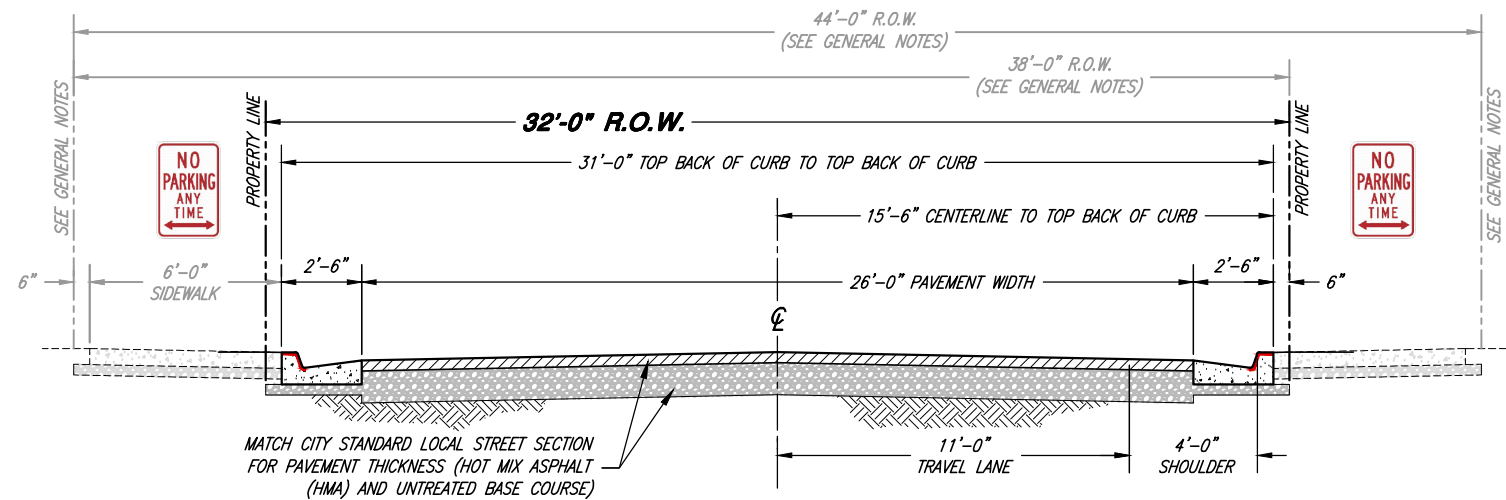

**32' RIGHT-OF-WAY  
PRIVATE ROADWAY STREET SECTION B**

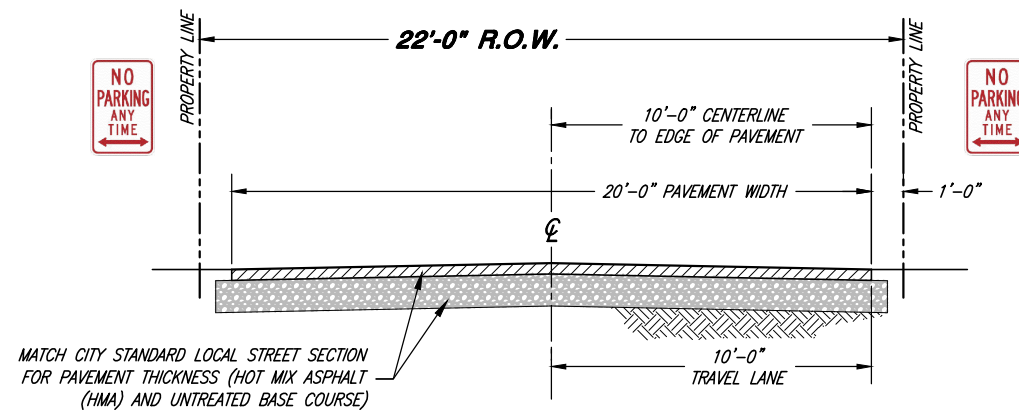

**22' RIGHT-OF-WAY  
PRIVATE ROADWAY STREET SECTION C**

**GENERAL NOTES:**

1. SIDEWALK OR PEDESTRIAN PATH MUST BE MADE AVAILABLE ON THE FRONT FACADE OF RESIDENCE AND CONNECT TO A PUBLIC RIGHT-OF-WAY WITHOUT HAVING TO CROSS A ROAD.
2. IF THE NUMBER OF AND SPACING REQUIRED FOR UTILITIES CANNOT FIT WITHIN THE PAVEMENT WIDTH, THEN THE PAVEMENT WIDTH AND R.O.W. MUST BE WIDENED TO ACCOMMODATE THE UTILITIES.



PROJECT ENGINEER  
*Brandon K. Jones*  
DATE 11/28/2023

REV.	DATE	APPR.

SCALE: N. T.S.  
DESIGNED: BKJ  
DRAWN: BEB  
CHECKED: BKJ



**CONSULTING ENGINEERS**  
6080 Fashion Point Drive  
South Ogden, Utah 84403 (801) 476-9767  
www.jonescivil.com

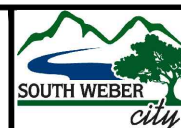

**SOUTH WEBER CITY CORPORATION**  
**PUBLIC WORKS - ROAD IMPROVEMENT STANDARDS**  
**PRIVATE ROADWAY STREET CROSS SECTION DETAILS**

SHEET: **R3**  
OF 34 SHEETS  
0

**STREET NOTES:**

- ① PRESSURIZED IRRIGATION SYSTEM LAYOUT AS APPROVED BY EITHER THE WEBER BASIN WATER CONSERVANCY DISTRICT, SOUTH WEBER WATER IMPROVEMENT DISTRICT, DAVIS AND WEBER COUNTIES CANAL COMPANY, OR THE SOUTH WEBER IRRIGATION COMPANY.
- ② EXACT LOCATION OF STREET AND REGULATORY SIGNS SHALL BE SPECIFIED BY THE PUBLIC WORKS DIRECTOR.
- ③ THE NUMBER OF VALVES REQUIRED AT EACH INTERSECTION SHALL BE DETERMINED BY THE CITY ENGINEER.

(NOTES CONTINUED BELOW)

**MAILBOX/CBU NOTES:**

- A1. MAILBOXES SHALL NOT BE PLACED IN THE SIDEWALK. NO MAILBOX OR CBU EDGES SHALL EXTEND PAST THE TBC.
- A2. PRIOR TO INSTALLATION, CONTACT THE LOCAL POSTMASTER FOR MAILBOX/CBU LOCATION APPROVAL.
- A3. FOLLOW USPS GUIDELINES & POLICIES FOR THE PLACEMENT, INSTALLATION, AND ACCESS REQUIREMENTS FOR ALL MAILBOX AND CBU UNITS.
- A4. INDIVIDUAL MAILBOXES SHALL ONLY BE PERMITTED FOR SINGLE FAMILY HOMES BUILT IN SUBDIVISIONS WITH EXISTING SINGLE MAILBOXES.



20' RADIUS FOR RESIDENTIAL;  
40' RADIUS FOR STATE ROADS  
OR AS APPROVED BY UDOT

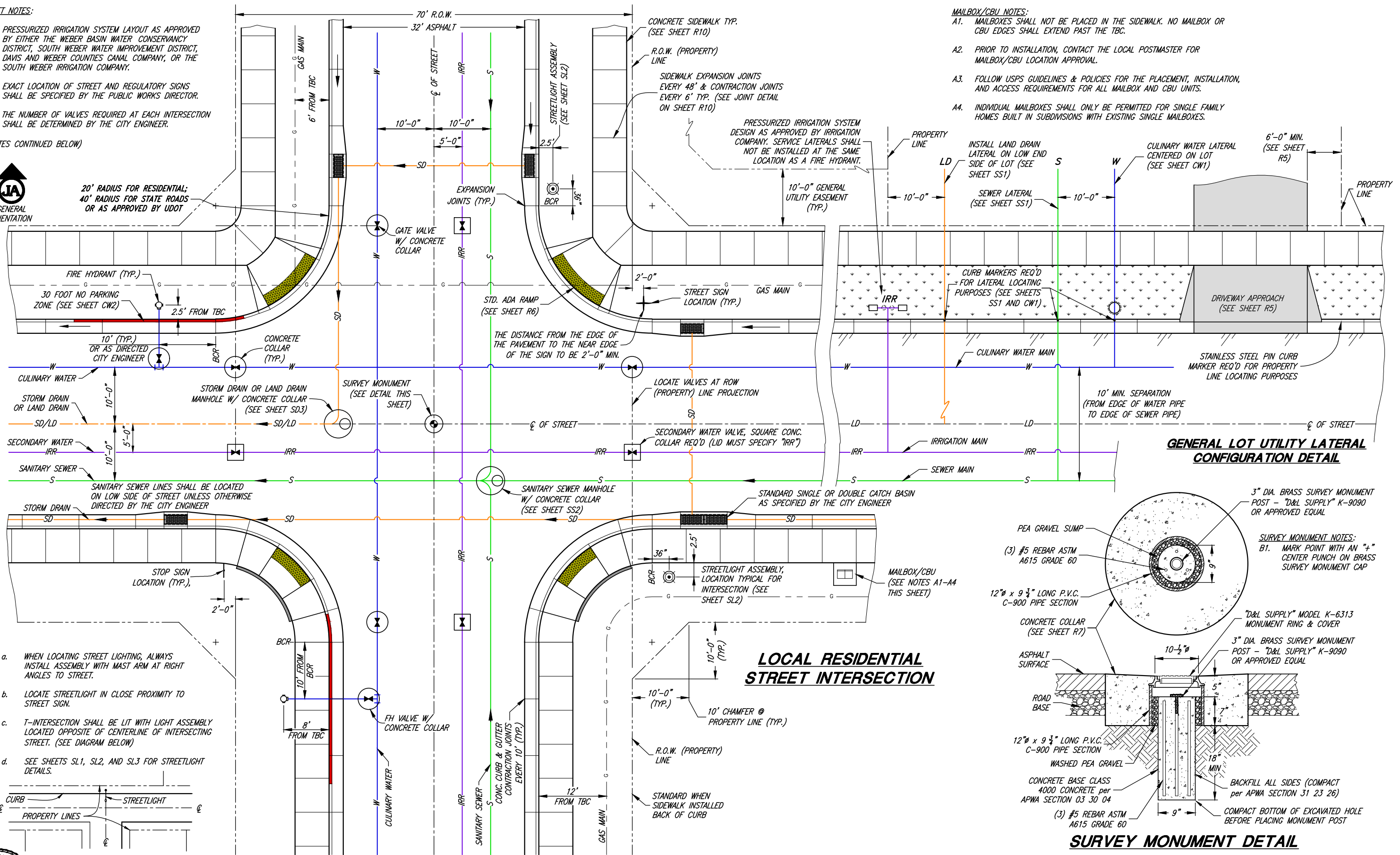

- a. WHEN LOCATING STREET LIGHTING, ALWAYS INSTALL ASSEMBLY WITH MAST ARM AT RIGHT ANGLES TO STREET.
- b. LOCATE STREETLIGHT IN CLOSE PROXIMITY TO STREET SIGN.
- c. T-INTERSECTION SHALL BE LIT WITH LIGHT ASSEMBLY LOCATED OPPOSITE OF CENTERLINE OF INTERSECTING STREET. (SEE DIAGRAM BELOW)
- d. SEE SHEETS SL1, SL2, AND SL3 FOR STREETLIGHT DETAILS.

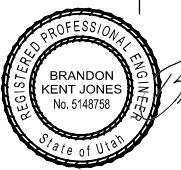
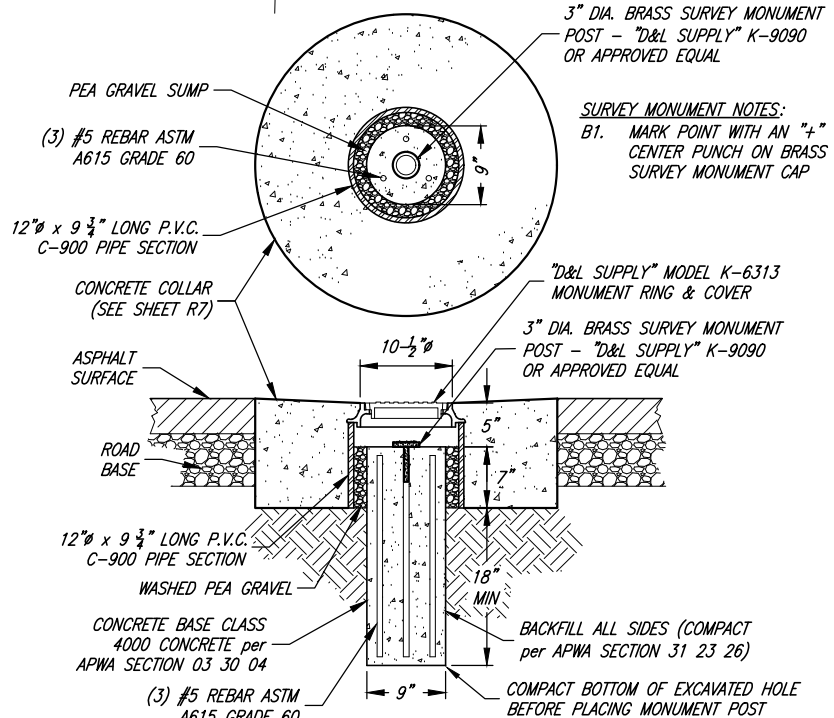
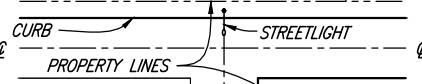

PROJECT ENGINEER	DATE	REV.	DATE	APPR.
Brandon K. Jones	11/28/2023			

SCALE:	DESIGNED	DRAWN	CHECKED
N. T.S.	BKJ	BEB	BKJ

**JA JONES & ASSOCIATES**  
CONSULTING ENGINEERS  
6080 Fashion Point Drive  
South Ogden, Utah 84403 (801) 476-9767  
www.jonescivil.com

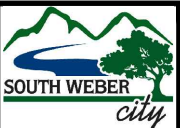

**SOUTH WEBER CITY CORPORATION**  
PUBLIC WORKS - ROAD IMPROVEMENT STANDARDS  
TYPICAL STREET INTERSECTION, UTILITY LATERAL CONFIGURATION & STREET MONUMENT DETAILS

**DRIVEWAY APPROACH NOTES:**

1. IN NEW SUBDIVISIONS WHERE FUTURE DRIVEWAY LOCATIONS ARE UNKNOWN, THE DRIVEWAY APPROACH SHALL BE MADE BY SAW CUTTING THE BACK OF THE EXISTING CURB TO THE REQUIRED DRIVEWAY WIDTH. ALL SAW CUTTING SHALL BE ACCOMPLISHED BY A CITY APPROVED LICENSED CONTRACTOR.
2. SCORE SIDEWALK 1/4 OF SIDEWALK THICKNESS AT EACH 6'-0" SECTION. EXPANSION JOINTS AT EACH 48'-0", PROVIDE ADDITIONAL CONTRACTION JOINTS ON OVERSIZED DRIVEWAYS AT 5'-0" MAX. SPACING
3. APPROACHES SHALL NOT BE ALLOWED ON CORNER LOTS WITHIN THE CLEAR VIEW AREA.
4. IF A RESIDENTIAL LOT HAS TWO FRONTAGES AND ONE OF THOSE FRONTAGES IS LOCATED ON A COLLECTOR OR ARTERIAL STREET, THE DRIVEWAY SHALL BE LOCATED ON THE RESIDENTIAL STREET ONLY. NO DRIVEWAY ACCESS WILL BE PERMITTED ONTO THE COLLECTOR OR ARTERIAL STREET.

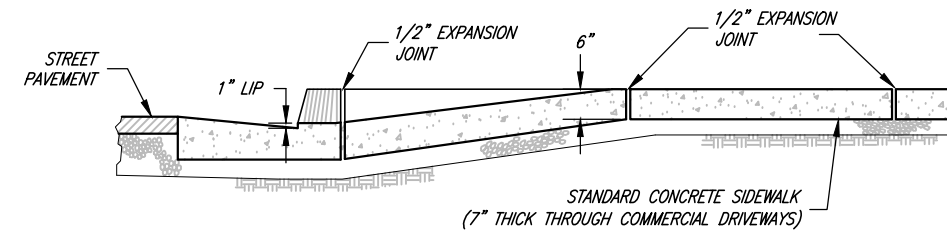

**SECTION A-A**

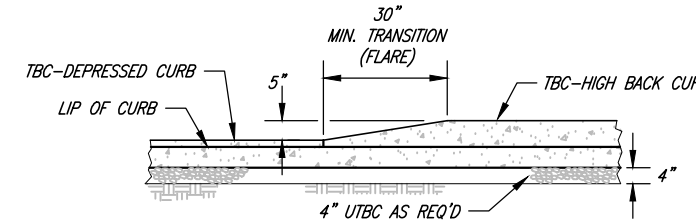

**SECTION B-B**

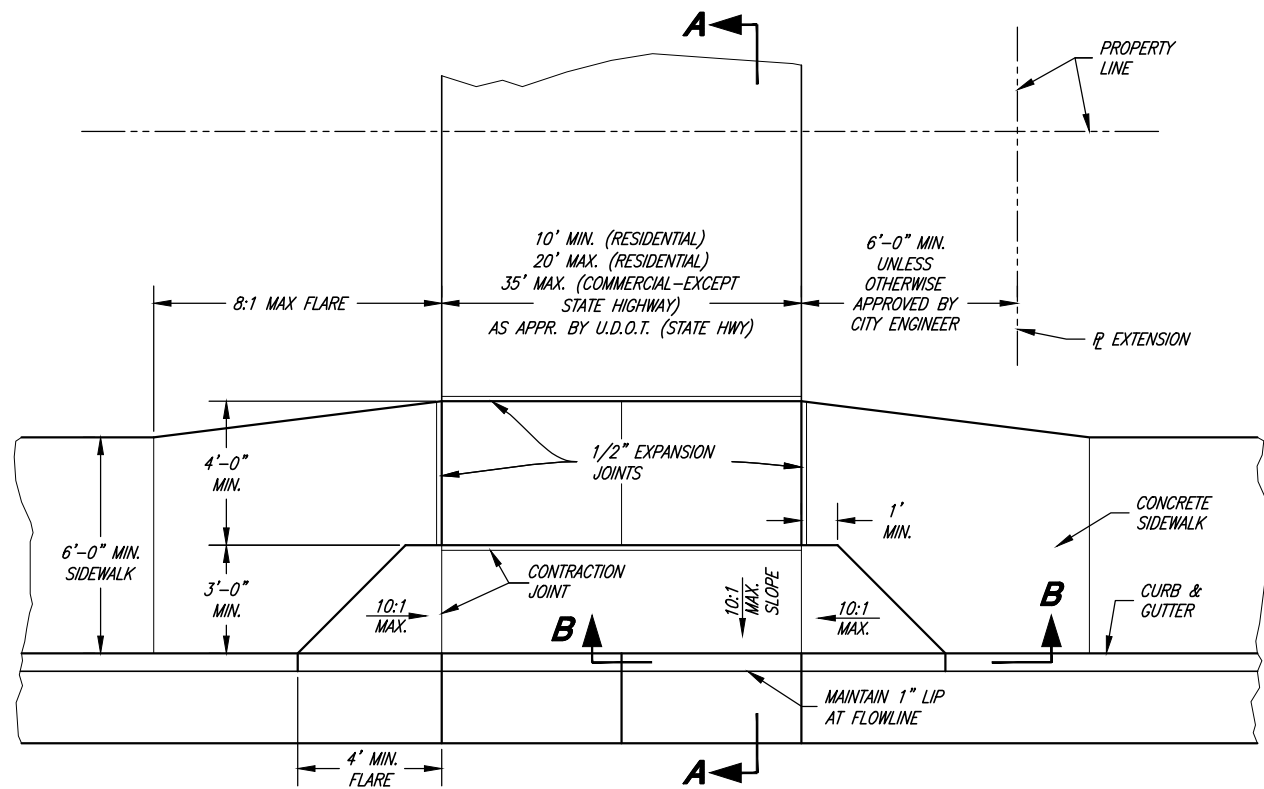

**DRIVEWAY APPROACH W/ ADJACENT SIDEWALK**

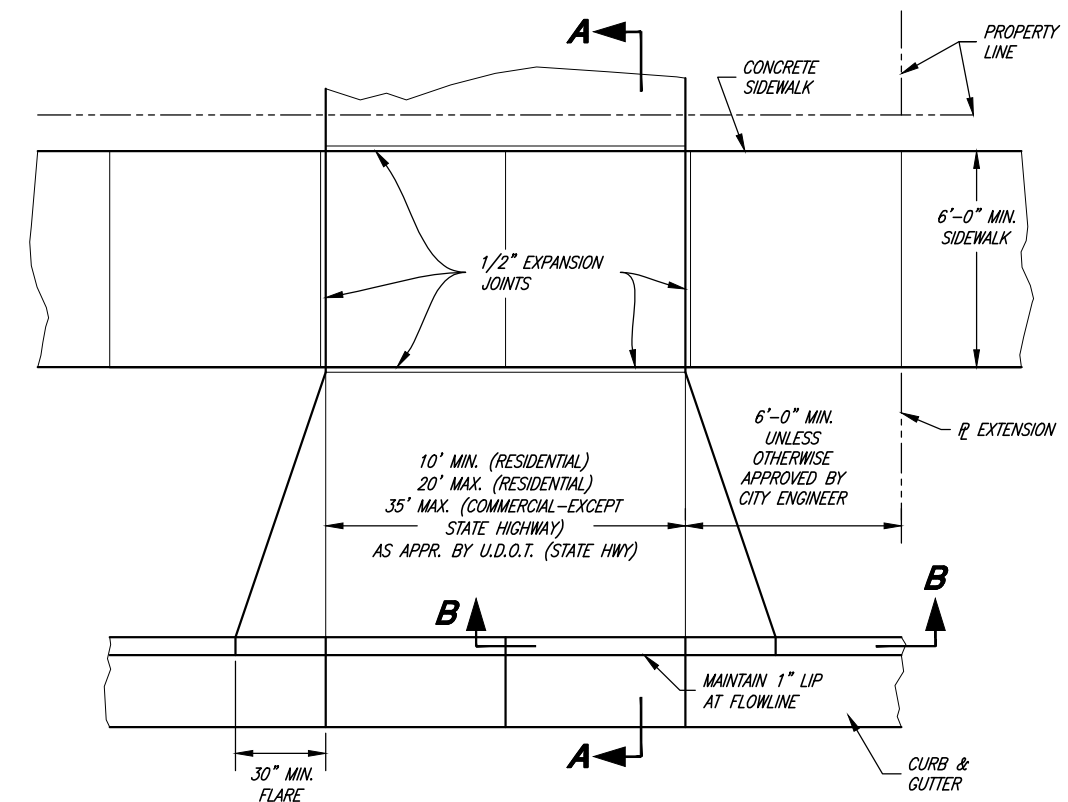

**DRIVEWAY APPROACH W/ PARKSTRIP**  
DROP DOWN STYLE (CITY STANDARD)



BRANDON KENT JONES  
No. 5148758  
PROJECT ENGINEER  
11/28/2023  
DATE

REV.	DATE	APPR.

SCALE:  
N. T.S.

DESIGNED BKJ  
DRAWN BEB  
CHECKED BKJ



**CONSULTING ENGINEERS**  
6080 Fashion Point Drive  
South Ogden, Utah 84403 (801) 476-9767  
www.jonescivil.com



**SOUTH WEBER CITY CORPORATION**  
**PUBLIC WORKS - ROAD IMPROVEMENT STANDARDS**  
**TYPICAL DRIVE APPROACH DETAILS**

SHEET:  
**R5**  
OF 34 SHEETS  
0



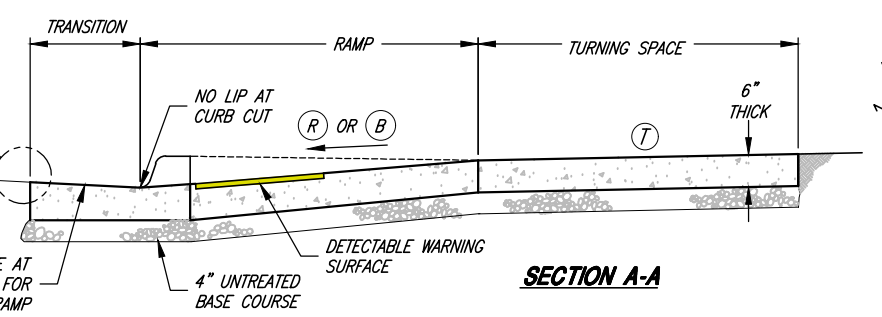
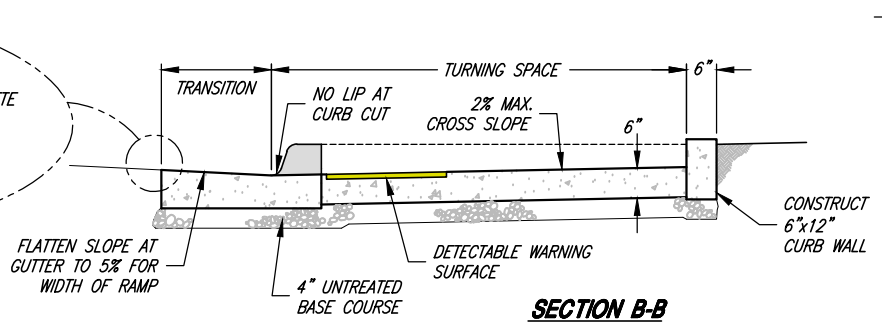
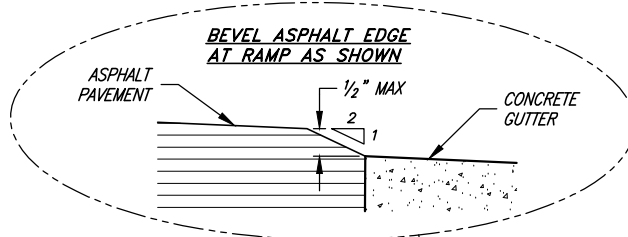

- GENERAL NOTES:**
1. INSTALLATION TOLERANCES ON CURB & GUTTER AND SIDEWALK PER APWA 32 16 13, 3.7.
  2. AS-BUILT SURVEY MAY BE REQUIRED TO VERIFY COMPLIANCE WITH TOLERANCES.
  3. GRINDING OF CONCRETE, TO MEET TOLERANCES, WILL NOT BE ALLOWED.

- DETECTABLE WARNING SURFACE NOTES:**
1. LOCATE THE DETECTABLE WARNING SURFACE SO THE OUTSIDE CORNER NEAREST THE STREET IS WITHIN 1 INCH OF THE BACK OF CURB (TBC). PROVIDE 2-FOOT MINIMUM DEPTH.
  2. PROVIDE DETECTABLE WARNING SURFACE FOR FULL WIDTH OF CURB CUT.
  3. THE DETECTABLE WARNING SURFACE DOMES SHALL BE ORIENTED SUCH THAT THE ROWS ARE PARALLEL WITH THE DIRECTION OF PEDESTRIAN TRAVEL TO THE RAMP ON THE OPPOSITE SIDE OF THE STREET.
  4. THE STANDARD COLOR FOR THE DETECTABLE WARNING SURFACE SHALL BE YELLOW OR PRE-APPROVED CONTRASTING COLOR. WHEN THE EXISTING SIDEWALK COLOR IS NOT STANDARD CONCRETE, THE COLOR OF THE DETECTABLE WARNING SURFACE SHALL BE DETERMINED BY THE CITY ENGINEER OR PUBLIC WORKS DIRECTOR.
  5. WHEN A DETECTABLE WARNING SURFACE DOME IS CUT, THE REMAINING PORTION OF THE DOME SHALL BE BEVELED TO A MAXIMUM SLOPE OF 1:2.

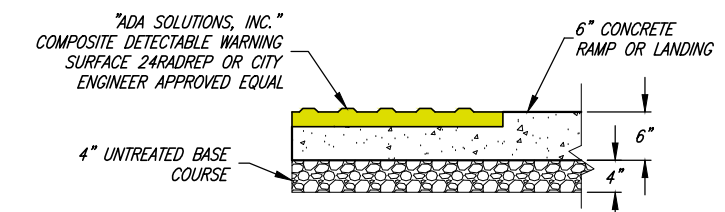

**DETECTABLE WARNING SURFACE DETAIL**

SLOPE REFERENCE TABLE			
ITEM	MAX RUNNING SLOPE*	MAX. CROSS SLOPE*	
(T) TURNING SPACE <sup>2</sup>	2% (1V:48H)	2% (1V:48H)	
(R) RAMP	8.3% (1V:12H)	2% (1V:48H)	
(S) SIDEWALK	5% (1:20) <sup>1</sup>	2% (1V:48H)	
(F) FLARE	25% (1V:4H)	--	
(B) BLENDED TRANSITION	5% (1V:20H) 2% MIN.	2% (1V:48H)	

\* RUNNING SLOPE IS IN THE DIRECTION OF PEDESTRIAN TRAVEL. CROSS SLOPE IS PERPENDICULAR TO PEDESTRIAN TRAVEL.  
<sup>1</sup> 5% MAX OR NATURAL SLOPE OF LAND  
<sup>2</sup> NOT TO EXCEED 2% IN ANY DIRECTION

- ADA RAMP NOTES:**
- WHERE DESIGNATED BY THE CITY, ALTERNATE UDOT OR APWA RAMP DESIGNS MAY BE USED WITH PRIOR APPROVAL OF THE CITY ENGINEER AND THE CITY PUBLIC WORKS DEPARTMENT. SUBMIT ENGINEERED CONSTRUCTION PLANS TO CITY ENGINEER FOR REVIEW AND ACCEPTANCE PRIOR TO CONSTRUCTION.
  - SITE CONDITIONS WILL VARY. CONFIGURATION OF RAMP, LANDING, AND TRANSITION MAY BE CHANGED, BUT THEY MUST MEET THE DIMENSIONS AND SLOPES AS SHOWN IN THE MOST RECENT EDITION OF THE U.D.O.T. STANDARDS & SPECIFICATIONS (SHEETS PA1 THROUGH PA5). THE USE OF FLARES, CURB WALLS, ETC. ARE AT THE DISCRETION OF THE ENGINEER.
  - LOCATE CURB CUT WITHIN CROSSWALK.
  - RAMP GRADE BREAK MUST BE PERPENDICULAR TO THE RUNNING SLOPE.

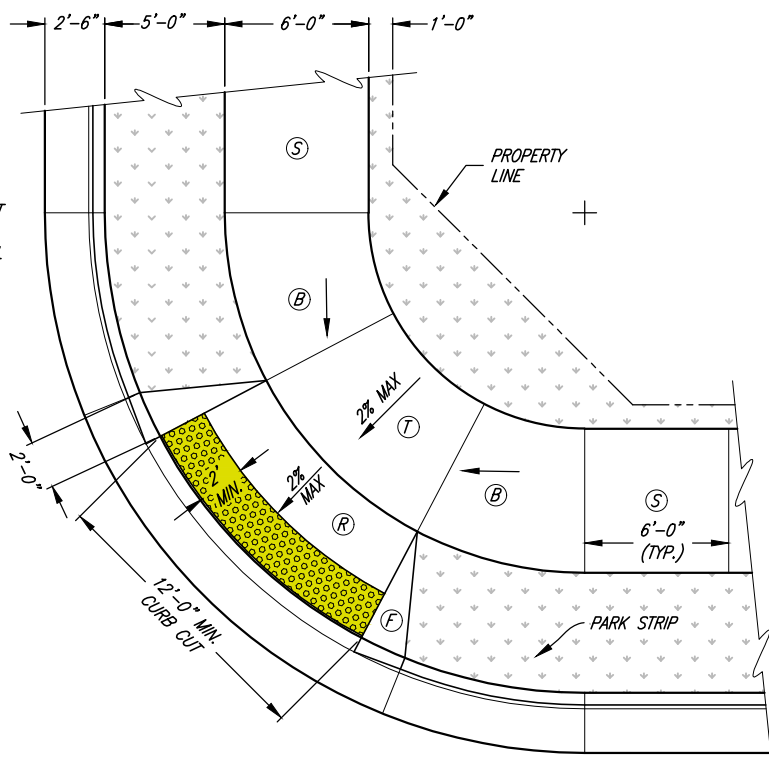

**ADA RAMP-DETAIL "D"**  
(COLLECTOR STREET SECTION)

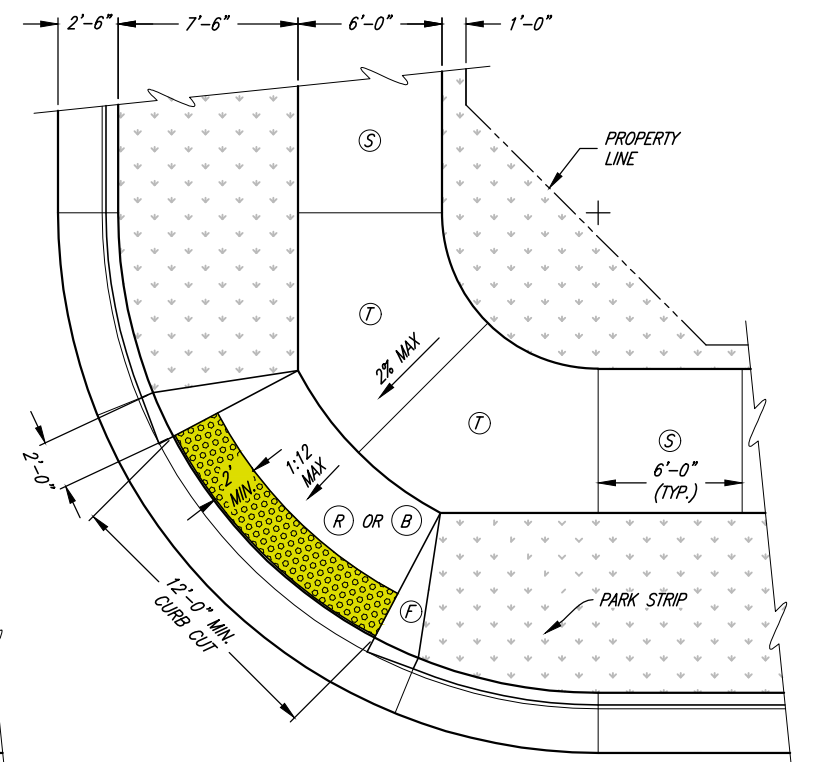

**ADA RAMP-DETAIL "C"**  
(SPECIAL RESIDENTIAL STREET SECTION)

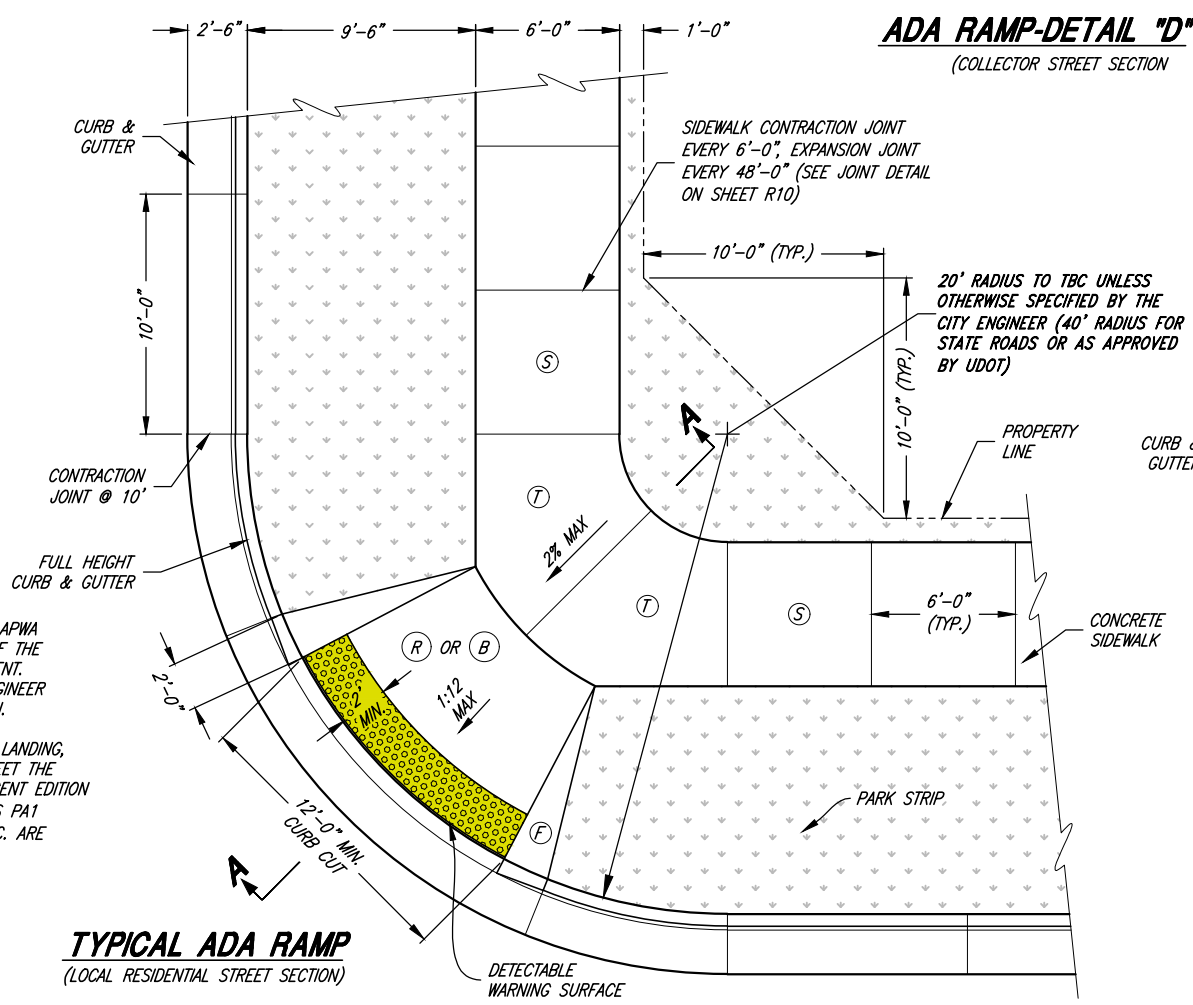

**TYPICAL ADA RAMP**  
(LOCAL RESIDENTIAL STREET SECTION)

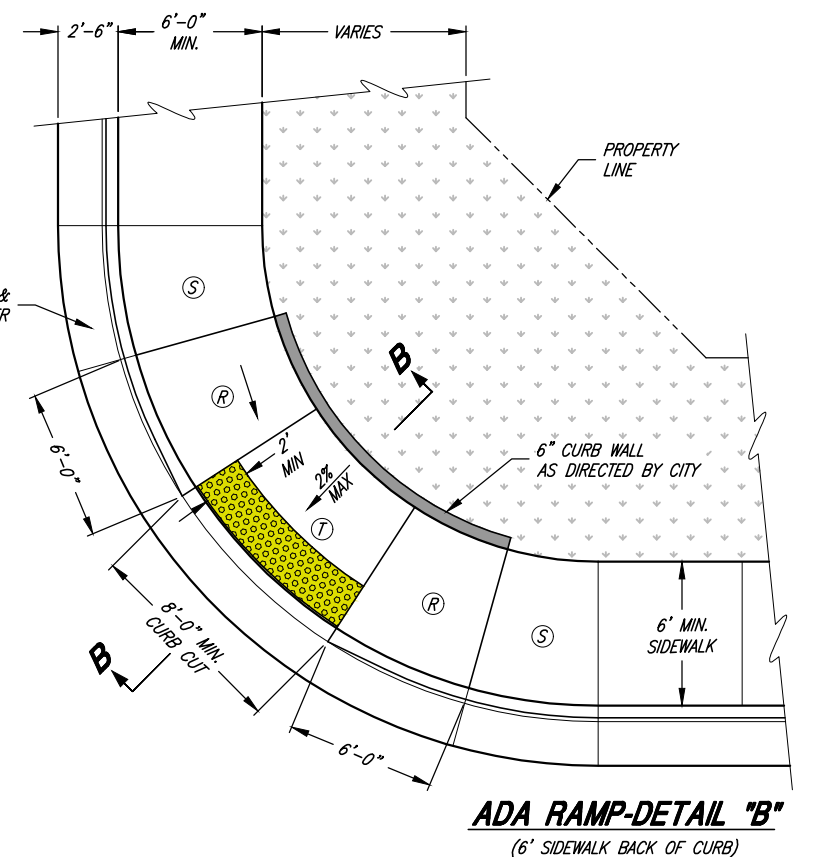

**ADA RAMP-DETAIL "B"**  
(6' SIDEWALK BACK OF CURB)



BRANDON K. JONES  
 PROJECT ENGINEER  
 11/28/2023  
 DATE

REV.	DATE	APPR.

SCALE:  
 N. T.S.  
 DESIGNED: BKJ  
 DRAWN: BEB  
 CHECKED: BKJ



**CONSULTING ENGINEERS**  
 6080 Fashion Point Drive  
 South Ogden, Utah 84403 (801) 476-9767  
 www.jonescivil.com

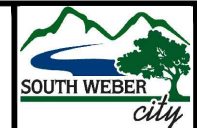

**SOUTH WEBER CITY CORPORATION**  
**PUBLIC WORKS - ROAD IMPROVEMENT STANDARDS**  
**TYPICAL ADA RAMP DETAILS**

SHEET:  
**R6**  
 OF 34 SHEETS  
 0



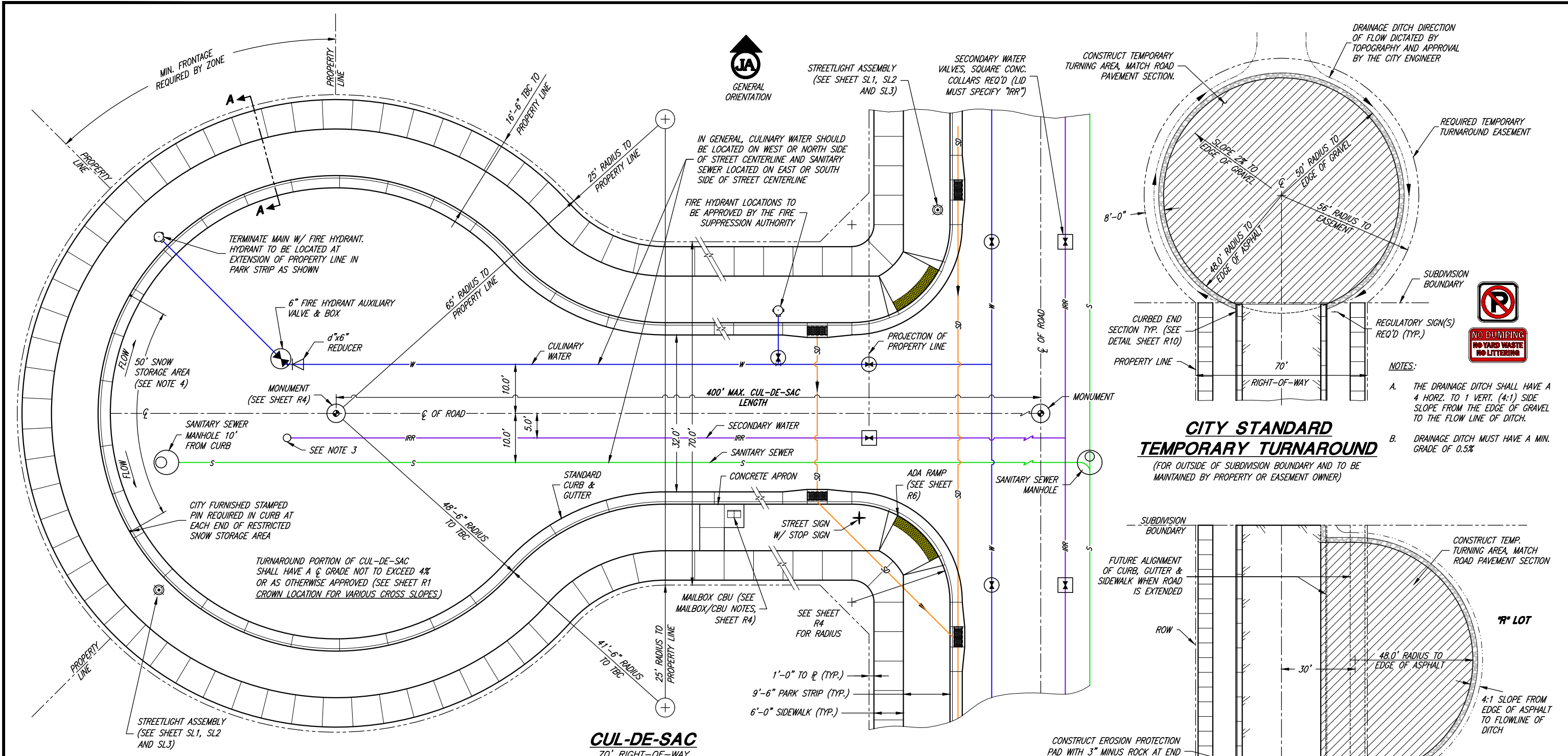

**CITY STANDARD TEMPORARY TURNAROUND**  
(FOR OUTSIDE OF SUBDIVISION BOUNDARY AND TO BE MAINTAINED BY PROPERTY OR EASEMENT OWNER)

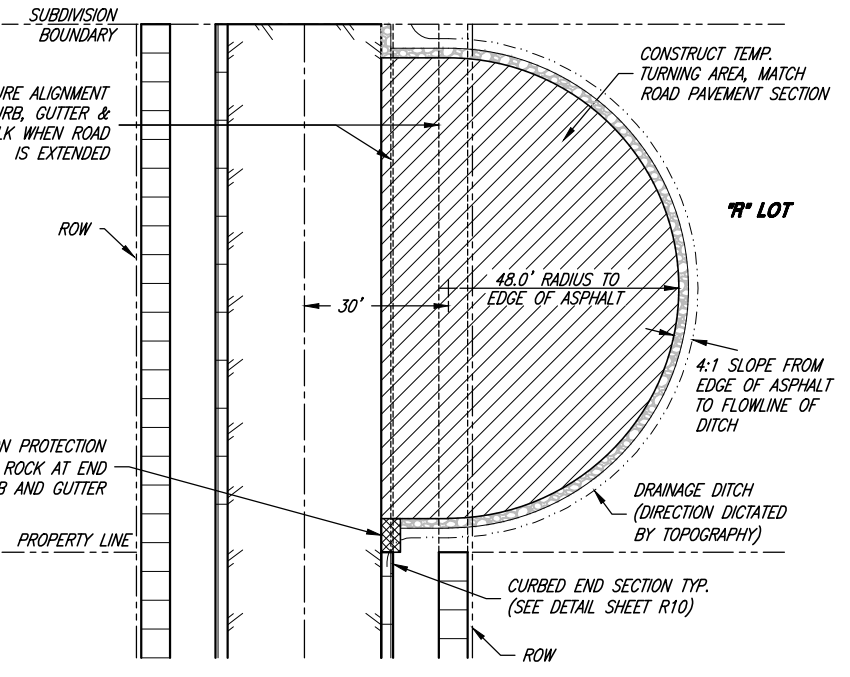

**TEMPORARY TURNAROUND**  
(FOR INSIDE SUBDIVISION BOUNDARY TO BE MAINTAINED BY PROPERTY OWNER)

**CUL-DE-SAC**  
70' RIGHT-OF-WAY

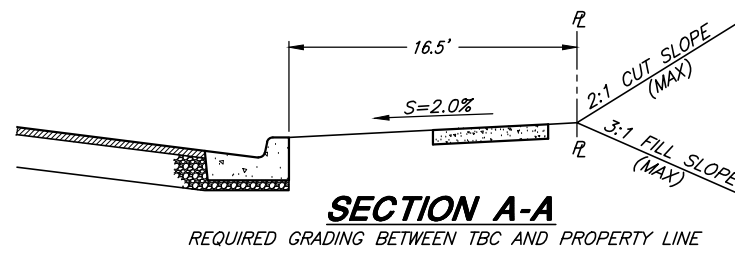

- GENERAL NOTES:**
1. THE CIRCULAR CUL-DE-SAC LAYOUT ON THIS SHEET IS THE CITY STANDARD DESIGN. OTHER ALTERNATE DESIGNS MAY BE CONSIDERED AS APPROVED BY THE CITY ENGINEER.
  2. MODIFIED CUL-DE-SACS (KNUCKLE, EYEBROW, BULB, OR HALF CUL-DE-SACS) ARE NOT PERMITTED.
  3. DEVELOPER SHALL PROVIDE AN AIR RELIEF OR BLOW-OFF AS DETERMINED BY THE SECONDARY WATER PROVIDER AND IN ACCORDANCE WITH THEIR STANDARDS AND APPROVED BY THE CITY ENGINEER.
  4. NO DRIVEWAYS, FIRE HYDRANTS, OR MAIL BOXES ARE PERMITTED WITHIN THE 50' SNOW STORAGE AREA.



BRANDON K. JONES  
PROJECT ENGINEER  
11/28/2023  
DATE

REV.	DATE	APPR.

SCALE:  
N. T.S.

DESIGNED BKJ  
DRAWN BEB  
CHECKED BKJ



**CONSULTING ENGINEERS**  
6080 Fashion Point Drive  
South Ogden, Utah 84403 (801) 476-9767  
www.jonescivil.com

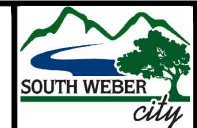

**SOUTH WEBER CITY CORPORATION**  
PUBLIC WORKS - ROAD IMPROVEMENT STANDARDS  
**CUL-DE-SAC & TEMPORARY TURNAROUND DETAILS**

SHEET:  
**R7**  
OF 34 SHEETS  
0

**GENERAL NOTES:**

1. THE CIRCULAR CUL-DE-SAC LAYOUT ON THIS SHEET IS THE CITY STANDARD DESIGN FOR PRIVATE ROADS. OTHER ALTERNATE DESIGNS MAY BE CONSIDERED AS APPROVED BY THE CITY.
2. ALL CULINARY WATER MAINS AND SERVICES MUST MAINTAIN A MINIMUM SEPARATION FROM ALL SEWER MAINS AND LATERALS OF 10'-0" HORIZONTAL AND 18" VERTICAL IN ACCORDANCE WITH THE STATE OF UTAH DIVISION OF DRINKING WATER RULES SECTION R309-550-7
3. NATURAL GAS, POWER AND COMMUNICATION LINES SHALL BE LOCATED BEHIND PROPERTY LINES OR IN LOT EASEMENTS.
4. THE PRIVATE ROAD CROSS SECTION IS NOT PERMITTED ON THROUGH ROADS.
5. ALL PRIVATE ROADS SHALL TERMINATE WITH A TURNAROUND.

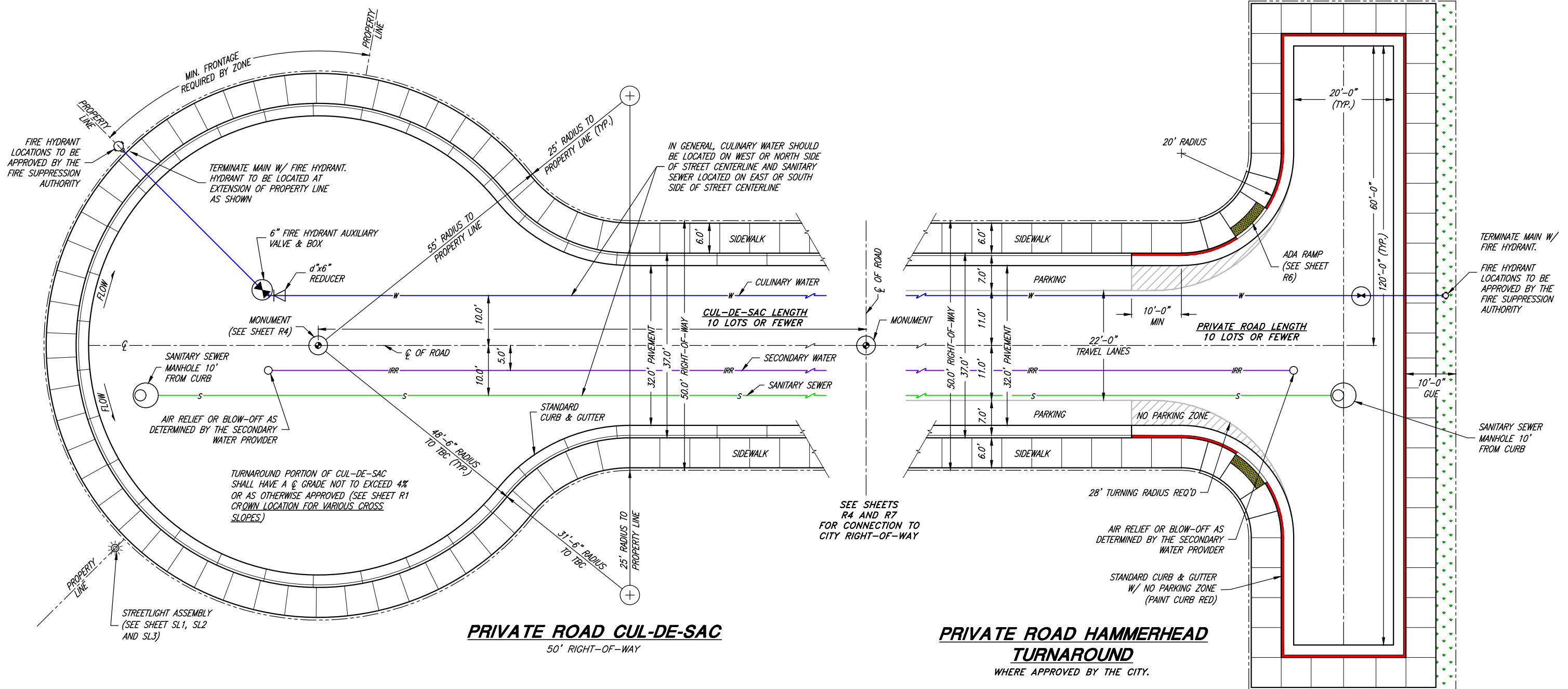

BRANDON KENT JONES  
No. 5148758  
PROJECT ENGINEER  
11/28/2023  
DATE

REV.	DATE	APPR.

SCALE:  
N. T.S.  
DESIGNED BKJ  
DRAWN BEB  
CHECKED BKJ



**CONSULTING ENGINEERS**  
6080 Fashion Point Drive  
South Ogden, Utah 84403 (801) 476-9767  
www.jonescivil.com

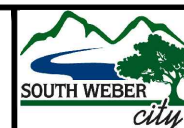

**SOUTH WEBER CITY CORPORATION**  
**PUBLIC WORKS - ROAD IMPROVEMENT STANDARDS**  
**PRIVATE ROAD CUL-DE-SAC AND HAMMERHEAD TURNAROUND DETAILS**

SHEET:  
**R8**  
OF 34 SHEETS  
0

**STREET SIGN NOTES:**

- A. STREET SIGN BACKGROUND SHALL BE REGULATORY GREEN, BOTH STREET AND TRAFFIC SIGNS SHALL BE AT THE VERY LEAST HIGH INTENSITY REFLECTIVE SHEETING (9FP-85 TYPE IIIA)
- B. LEGEND SHALL BE WHITE LETTERS (FONT: HIGHWAY C), HIGH INTENSITY REFLECTIVE SHEETING (9FP-85 IIIA)
- C. SIGN BLANK SHALL BE 6081-T6 HEAT TREATED HIGH TENSILE DEGREASED ALUMINUM W/ ALODINE 1200 FINISH-THICKNESS SHALL BE 0.08"
- D. EACH SIGN SHALL CONSIST OF TWO PLATES RIVETED TOGETHER & MOUNTED AS SHOWN
- E. SIGNS ON PRIVATE ROADS SHALL MEET ALL SPECIFICATIONS FOR STANDARD SIGNS. (PRIVATE SIGNS WILL NOT BE MAINTAINED BY THE CITY.)
- F. ALL STREETS WITH NAMES MUST ALSO SHOW COORDINATE DESIGNATION
- G. ALL SIGNS SHALL CONFORM TO THE REQUIREMENTS OF THE CURRENT "MANUAL ON UNIFORM TRAFFIC CONTROL DEVICES"

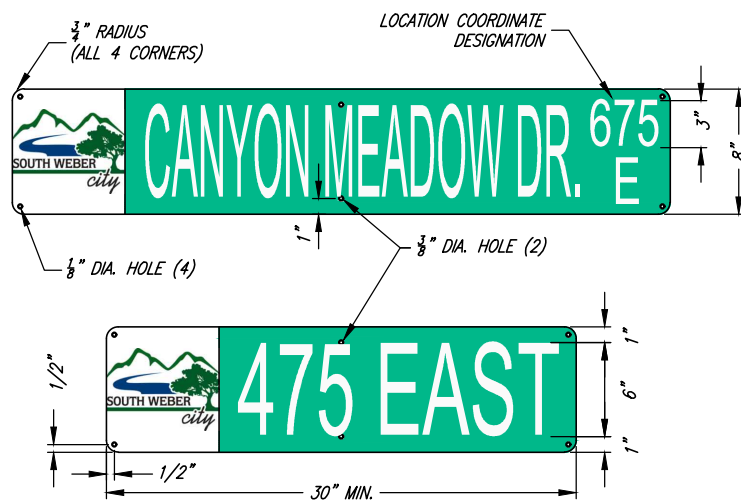

**CITY STANDARD PLATE DETAIL**



**PRIVATE ROAD PLATE DETAIL**  
(SEE STREET SIGN NOTE E THIS SHEET)

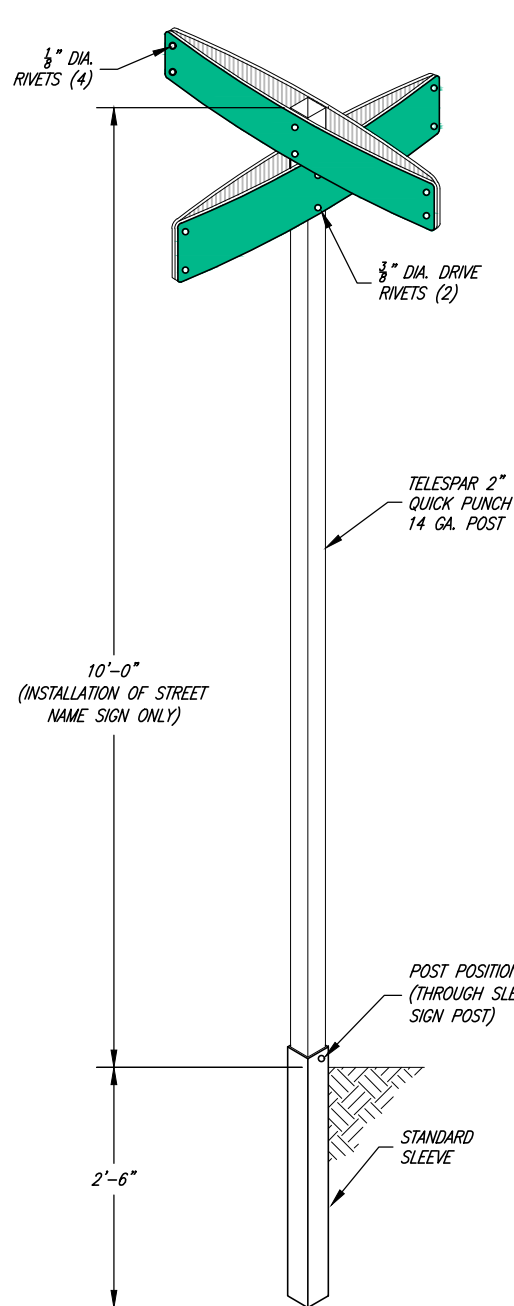

**STREET SIGN & POST**

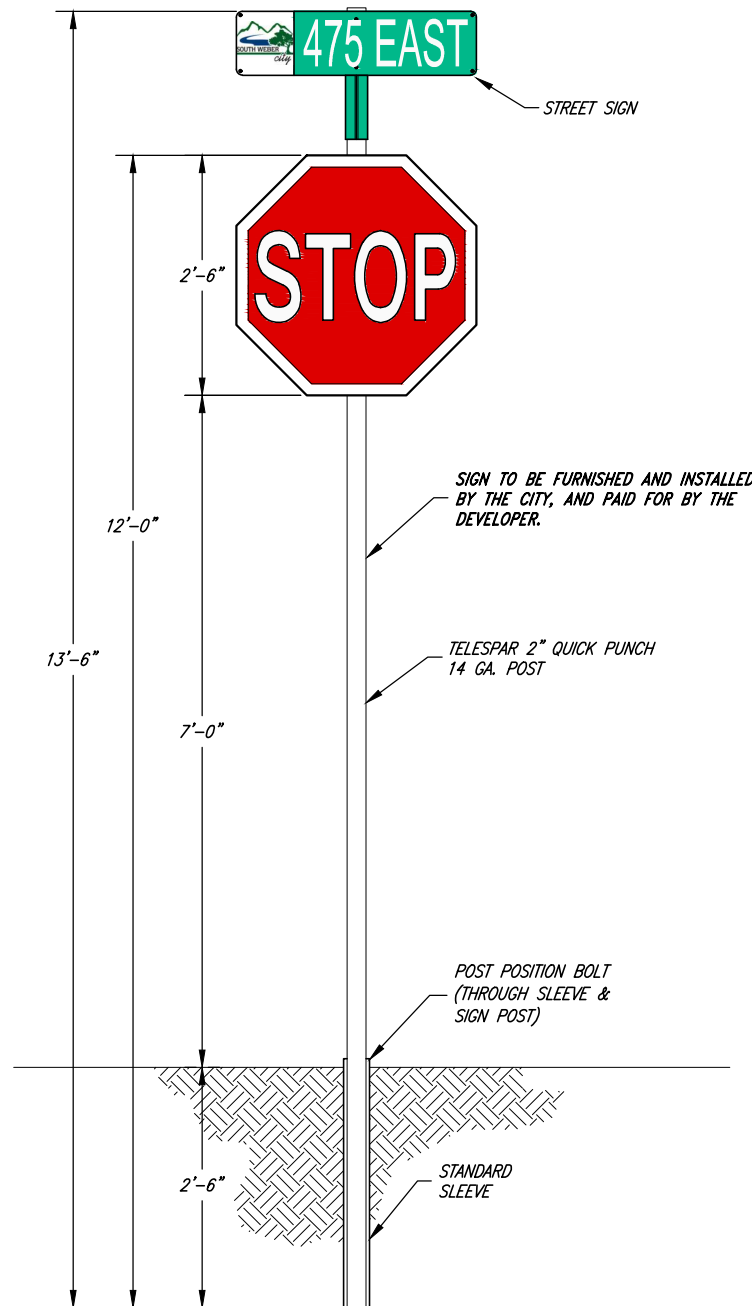

**STREET / TRAFFIC SIGN & POST**

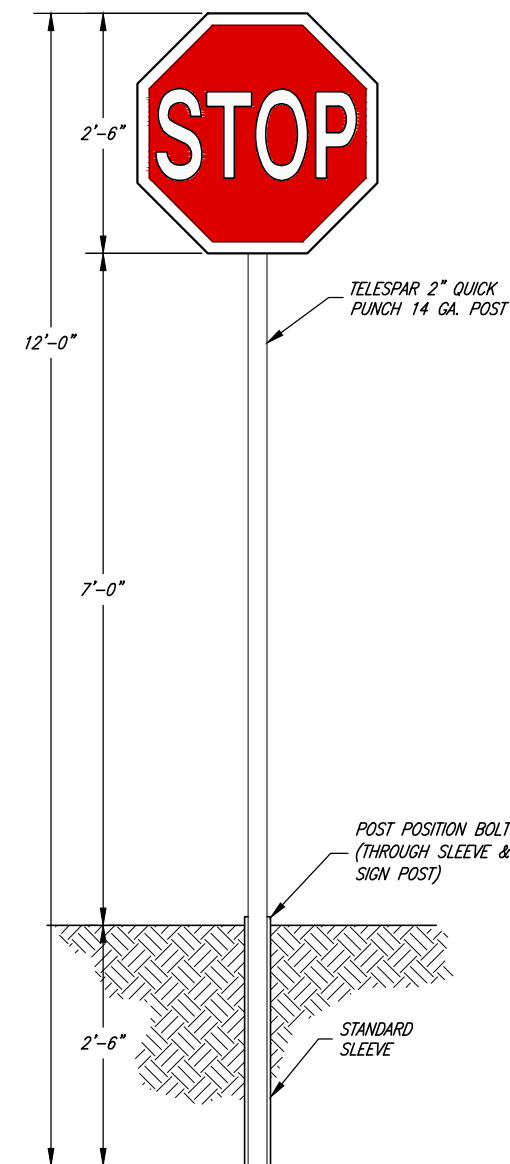

**TRAFFIC SIGN & POST**



BRANDON KENT JONES  
No. 5148758  
PROJECT ENGINEER  
11/28/2023  
DATE

REV.	DATE	APPR.

SCALE:  
N. T.S.

DESIGNED BKJ  
DRAWN BEB  
CHECKED BKJ



**CONSULTING ENGINEERS**  
6080 Fashion Point Drive  
South Ogden, Utah 84403 (801) 476-9767  
www.jonescivil.com

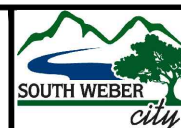

**SOUTH WEBER CITY CORPORATION**  
**PUBLIC WORKS - ROAD IMPROVEMENT STANDARDS**  
**STREET SIGN DETAILS**

SHEET:  
**R9**  
OF 34 SHEETS  
0



**CONCRETE COLLAR NOTES:**

- B1. ALL CONCRETE COLLARS TO BE INSTALLED WITHIN 14 DAYS AFTER PAVING.
- B2. COLLARS AROUND MANHOLES AND CULINARY WATER VALVES ARE TO BE ROUND.
- B3. COLLARS AROUND IRRIGATION VALVES AND MANHOLES ARE TO BE SQUARE.
- B4. FIBER MESH SHALL BE ADDED TO ALL CONCRETE (1 lb PER CUBIC YARD).

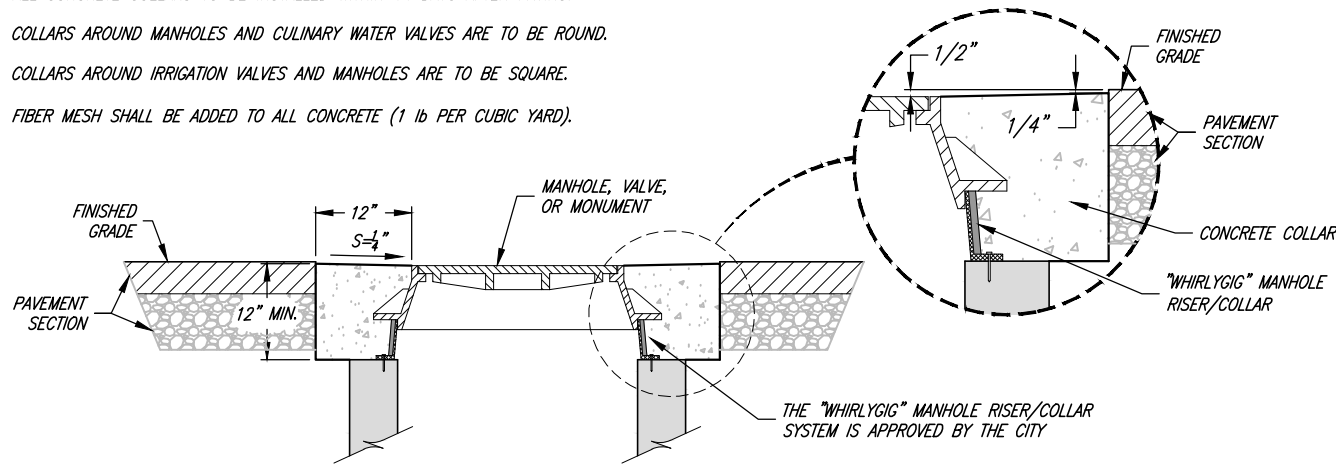

**CONCRETE COLLAR DETAIL**

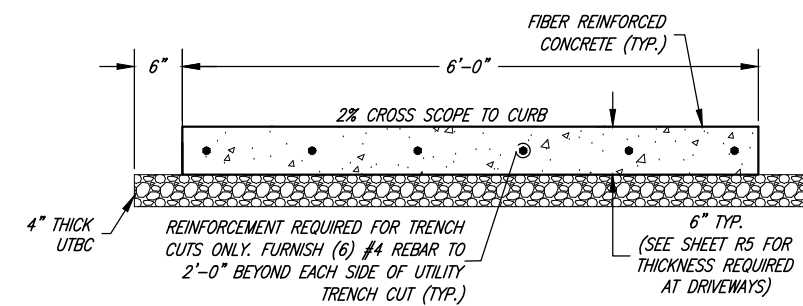

**SIDEWALK SECTION**  
(CITY STANDARD)

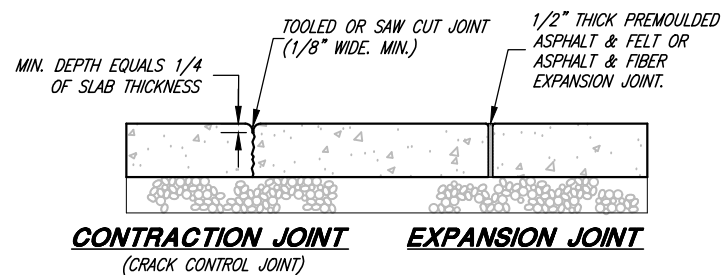

**JOINT DETAIL**

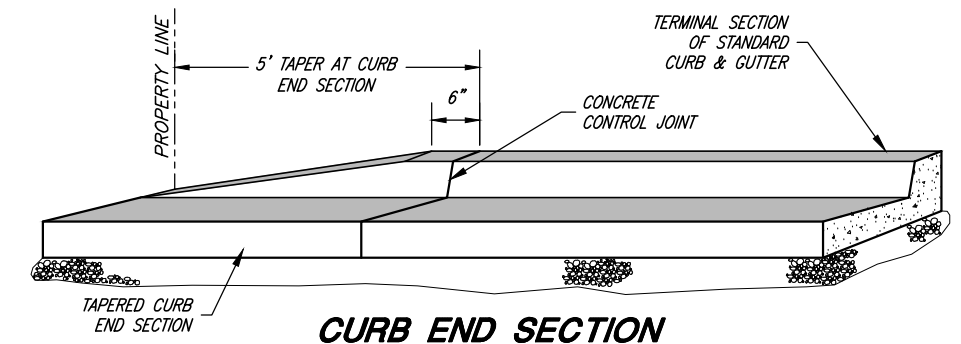

**CURB END SECTION**

**CURB END SECTION NOTE:**

CONSTRUCT CURB END SECTION FOR IMPROVED SAFETY AND TO PREVENT SNOW PLOW DAMAGE. CONTRACTOR REQUIRED TO SAW-CUT AND REMOVE TAPERED CURB END SECTION AND CONSTRUCT NEW CURB AND GUTTER WHEN CURB AND GUTTER IS EXTENDED.

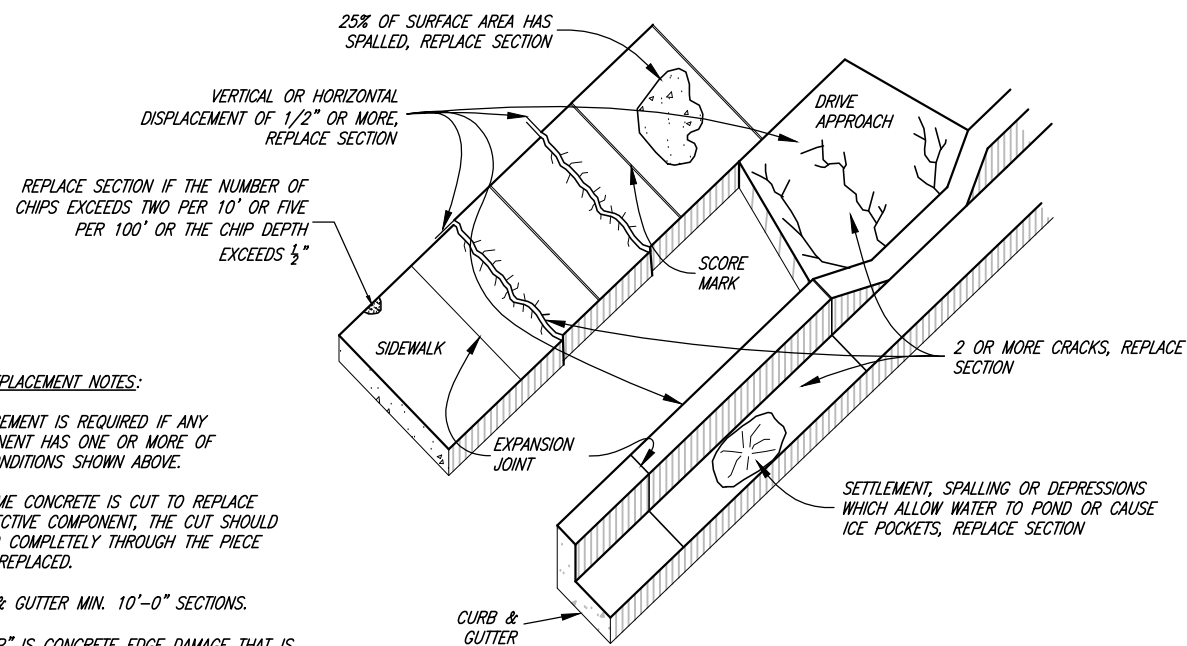

**DEFECTIVE CONCRETE REPLACEMENT CRITERIA**

**CONCRETE REPLACEMENT NOTES:**

- A. REPLACEMENT IS REQUIRED IF ANY COMPONENT HAS ONE OR MORE OF THE CONDITIONS SHOWN ABOVE.
- B. ANY TIME CONCRETE IS CUT TO REPLACE A DEFECTIVE COMPONENT, THE CUT SHOULD EXTEND COMPLETELY THROUGH THE PIECE BEING REPLACED.
- C. CURB & GUTTER MIN. 10'-0" SECTIONS.
- D. A "CHIP" IS CONCRETE EDGE DAMAGE THAT IS DEEPER THAN 1/4" AND LARGER THAN 2" DIA.

**GENERAL NOTES:**

- A1. INSTALLATION TOLERANCES ON CURB & GUTTER AND SIDEWALK PER APWA 32 16 13, 3.7.
- A2. AS-BUILT SURVEY MAY BE REQUIRED TO VERIFY COMPLIANCE WITH TOLERANCES.
- A3. GRINDING OF CONCRETE, TO MEET TOLERANCES, WILL NOT BE ALLOWED.
- A4. CONCRETE CLASS: WHEN NOT SPECIFIED IN THE PLANS OR PROJECT SPECIFICATION, USE THE FOLLOWING TABLE TO SELECT THE CLASS OF CONCRETE REQUIRED FOR THE APPLICATION.

CONCRETE CLASS	APPLICATION
5,000	REINFORCED STRUCTURAL CONCRETE
4,000	SIDEWALKS, CURB, GUTTER, CROSS GUTTERS, WATERWAYS, PAVEMENTS, AND UNREINFORCED FOOTINGS AND FOUNDATIONS
3,000	THRUST BLOCKS
2,000	ANCHORS, MASS CONCRETE

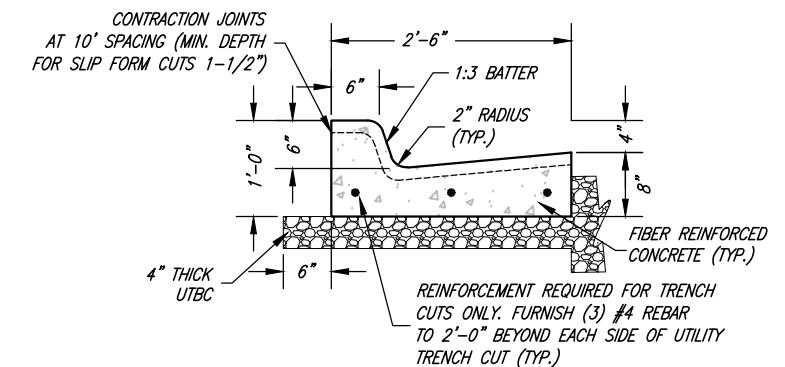

**CURB & GUTTER SECTION**  
(CITY STANDARD)

**CURB & GUTTER NOTES:**

- 1. WHEN REPLACING CURB DUE TO CONSTRUCTION ACTIVITY, NEW CURB MUST EXTEND 5' MIN. PAST TRENCH ON EACH SIDE.
- 2. CONCRETE CURB TO BE CONSTRUCTED USING SLIPFORMS, HAND FORMED OR STATIONARY FORMS ARE ONLY ALLOWED FOR CURB TIE-INS.
- 3. THE SLOPE FOR CURB & GUTTER MUST BE A MINIMUM OF 0.5%.



BRANDON KENT JONES  
No. 5148758  
PROJECT ENGINEER  
11/28/2023  
DATE

REV.	DATE	APPR.

SCALE:  
N. T.S.

DESIGNED BKJ  
DRAWN BEB  
CHECKED BKJ



**CONSULTING ENGINEERS**  
6080 Fashion Point Drive  
South Ogden, Utah 84403 (801) 476-9767  
www.jonescivil.com

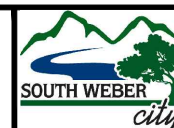

**SOUTH WEBER CITY CORPORATION**  
**PUBLIC WORKS - ROAD IMPROVEMENT STANDARDS**  
**TYPICAL SIDEWALK, CURB & GUTTER, CONCRETE COLLAR,**  
**AND DEFECTIVE CONC. REPLACEMENT DETAILS**

SHEET:  
**R10**  
OF 34 SHEETS  
0

BOND MATERIAL PROPERTIES		
PROPERTY	ASTM TEST METHOD	REQUIREMENTS
BOND STRENGTH, PSI (@ 70° F., 30 MIN. CURE)	C882	200 MIN.
COMPRESSIVE STRENGTH, PSI (@ 70° F., 60 MIN. CURE)	C109	1500 MIN.

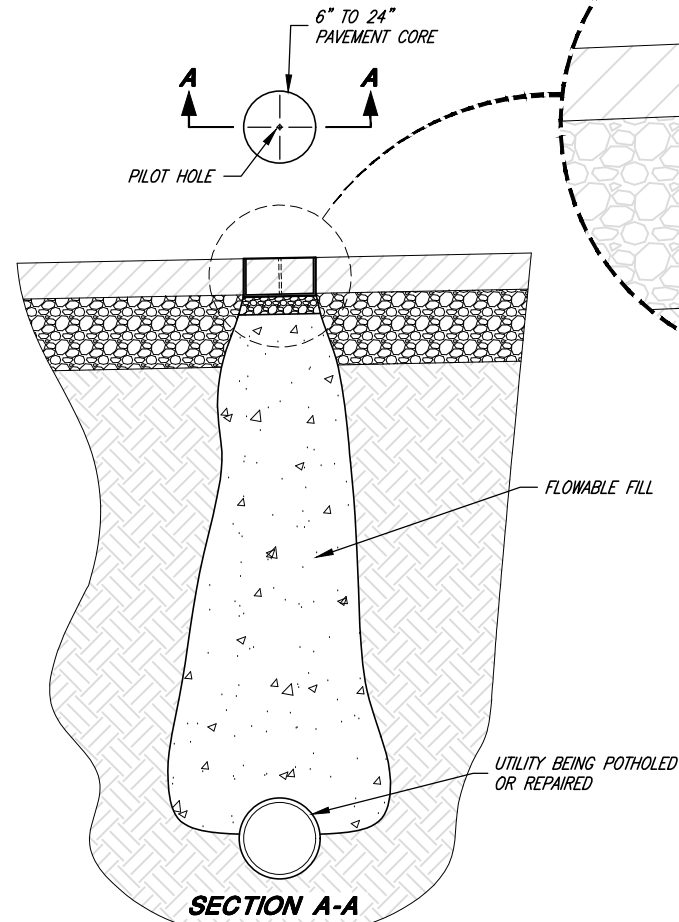

**UTILITY POTHOLES DETAIL**  
KEYHOLE METHOD

**UTILITY POTHOLES NOTES:**

- A1. CONTRACTOR SHALL PLACE A TEMPORARY PAINT MARK ON THE PAVEMENT TO ASSURE CORE IS REPLACED IN THE SAME ORIENTATION.
- A2. CORING SHALL BE COMPLETED PERPENDICULAR TO THE HORIZON (NOT THE PAVEMENT), AND SHALL EXTEND THE FULL ASPHALT DEPTH. CORING SHALL BE COMPLETED USING A KEYHOLE CORING SAW CAPABLE OF REMOVING AN INTACT CORE OF PAVEMENT.
- A3. CORES SHALL NOT BE LESS THAN 6 INCHES IN DIAMETER AND NO MORE THAN 24 INCHES IN DIAMETER.
- A4. SOIL SHALL BE REMOVED USING AIR/VACUUM EXTRACTION METHODS AND DISPOSED PROPERLY OFF SITE.
- A5. FLOWABLE FILL SHALL BE USED TO BACKFILL THE HOLE TO WITHIN ONE TO TWO INCHES OF THE BOTTOM OF THE EXISTING PAVEMENT.
- A6. COMPACTED GRAVEL IF NECESSARY SHALL BE USED TO BRING THE POTHOLE TO THE BOTTOM OF PAVEMENT GRADE. THE TEMPORARY PAINT MARK SHALL BE USED TO ALIGN THE CORE TO ITS ORIGINAL POSITION AND THE GRAVEL SHALL BE USED TO LEVEL THE CORE SO THE FINISH GRADE IS FLUSH WITH THE SURROUNDING ASPHALT.
- A7. PAVEMENT BONDING COMPOUND SHALL BE USED TO RESTORE THE CORE TO ITS ORIGINAL CONDITION COMPLETELY FLUSH WITH THE SURROUNDING ASPHALT. THE COMPOUND SHALL BE POURED IN THE POTHOLE AND THE CORE PLACE IN AFTER CAUSING THE PAVEMENT BONDING COMPOUND TO FLOW TO THE SURFACE. ALL EXCESS BONDING AGENT SHALL BE REMOVED.
- A8. CORES SHALL BE ALLOWED TO CURE PER MANUFACTURER'S RECOMMENDATIONS PRIOR TO OPENING TO TRAFFIC.

"UTILIBOND" PAVEMENT BONDING COMPOUND OR APPROVED EQUAL

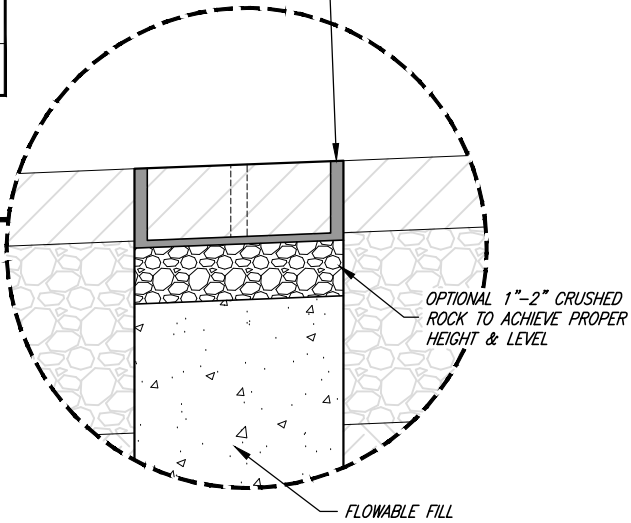

IF EDGE OF CUT IS WITHIN 5' OF LIP OF GUTTER, THE ASPHALT PATCH MUST EXTEND ALL THE WAY TO THE LIP OF GUTTER.

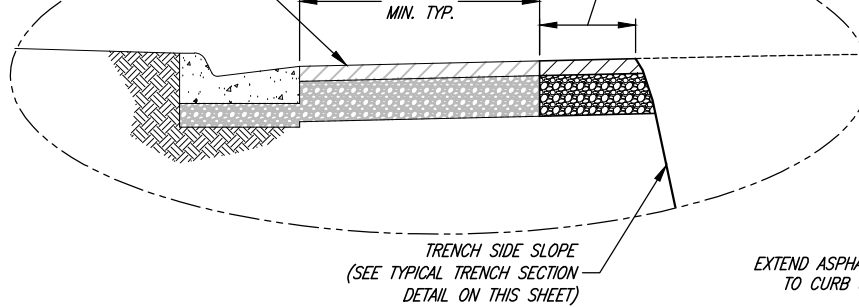

HOT MIX ASPHALT (HMA) PER CITY STANDARD SPECIFICATIONS. MATCH EXISTING PAVEMENT THICKNESS OR 4" MIN., WHICHEVER IS GREATER.

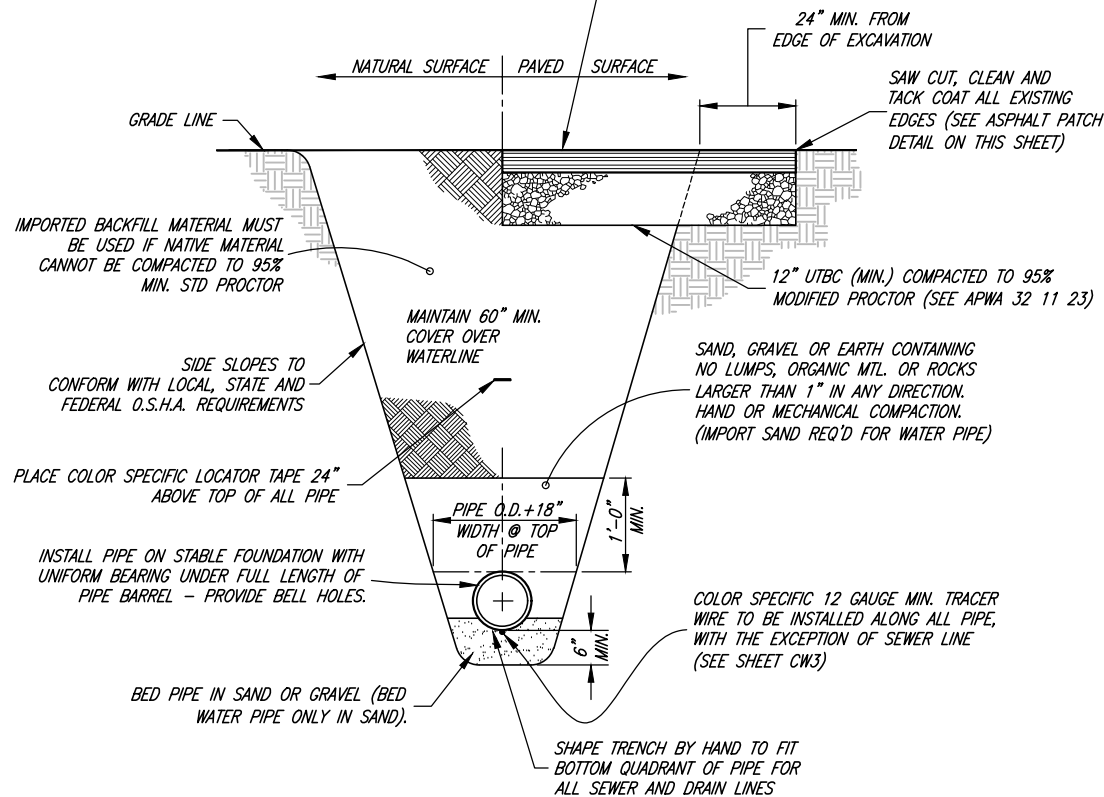

**TYPICAL TRENCH SECTION**  
(WATER, IRRIGATION, SEWER, STORM DRAIN, AND LAND DRAIN)

**TRENCH NOTES:**

- A. BACKFILL PER APWA 33 05 20.
- B. COMPACTION TEST REQUIRED AT SPRING-LINE FOR ALL P.V.C. OR H.D.P.E. PIPES.
- C. PAVEMENT RESTORATION PER APWA 33 05 25 AND CITY MODIFICATIONS.
- D. GRAVEL SURFACED AREAS, SUCH AS ROADS AND SHOULDERS, PARKING AREAS, AND UNPAVED DRIVEWAYS, SHALL BE REPAIRED WITH 8" THICK (MIN.) 1" UNTREATED BASE COURSE COMPACTED TO 95% MODIFIED PROCTOR.
- E. WATER & SEWER LINES, INCLUDING SERVICE LINES, SHALL NOT BE INSTALLED IN THE SAME TRENCH.

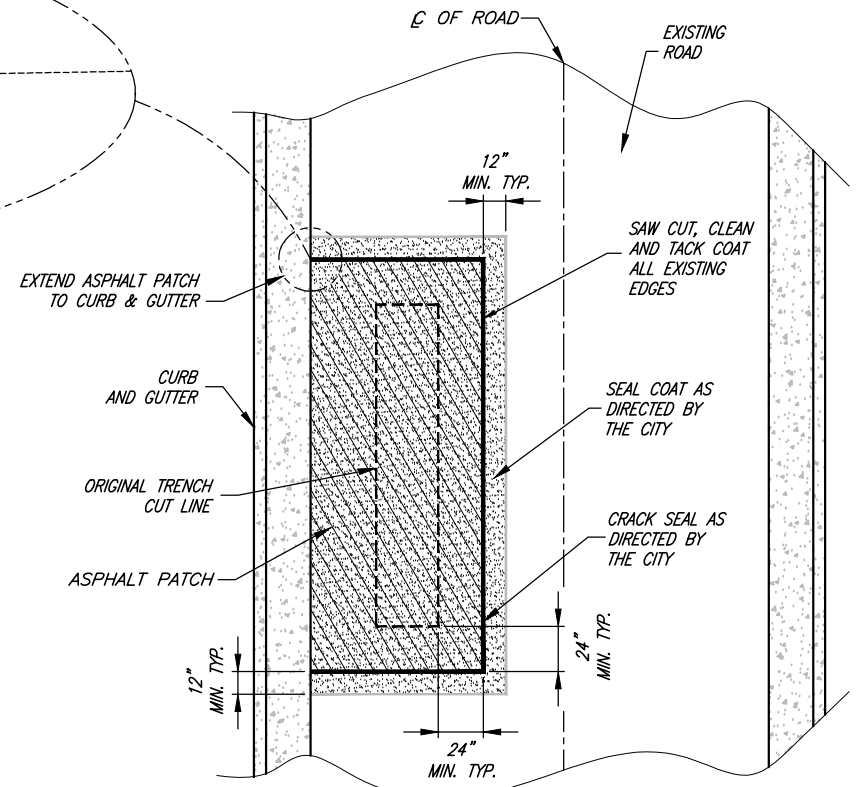

**TYPICAL PARALLEL ASPHALT PATCH PLAN**

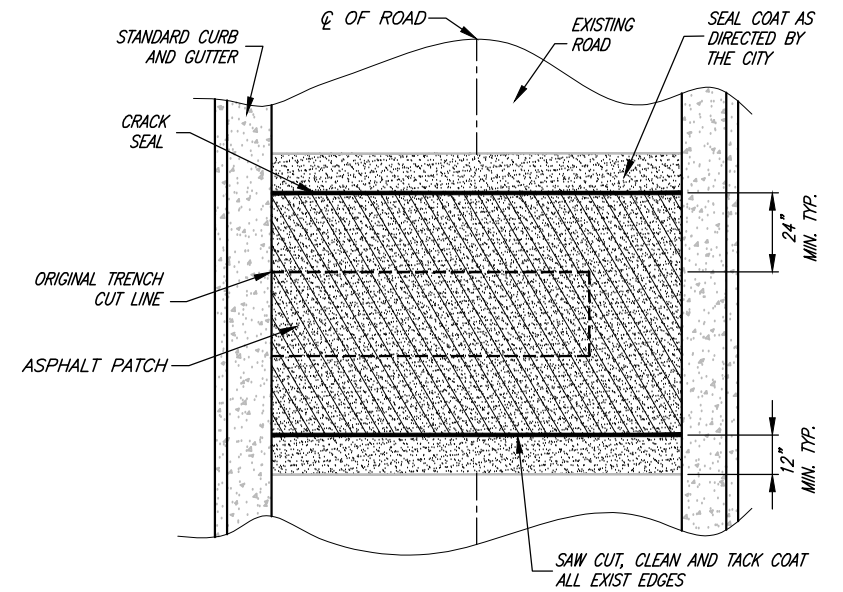

**TYPICAL HORIZONTAL ASPHALT PATCH PLAN**

**ASPHALT PATCH NOTE:**

1. ON ANY ROAD PAVED OR OVERLAYED WITHIN THE LAST 10 YEARS, THE PATCH MUST BE COMPLETED PER APWA PLAN 255 BITUMINOUS PAVEMENT T-PATCH. (SEE SHEET R12)
2. NO ANGLED ASPHALT PATCHING ALLOWED.



BRANDON KENT JONES  
No. 5148758  
PROJECT ENGINEER  
11/28/2023  
DATE

REV.	DATE	APPR.

SCALE:  
N. T.S.

DESIGNED BKJ  
DRAWN BEB  
CHECKED BKJ



**CONSULTING ENGINEERS**  
6080 Fashion Point Drive  
South Ogden, Utah 84403 (801) 476-9767  
www.jonescivil.com

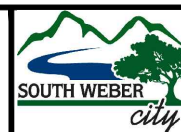

**SOUTH WEBER CITY CORPORATION**  
**PUBLIC WORKS - ROAD IMPROVEMENT STANDARDS**  
**UTILITY TRENCH, UTILITY POTHOLES, AND ASPHALT PATCH PLAN DETAILS**

SHEET:  
**R11**  
OF 34 SHEETS  
0



**BITUMINOUS PAVEMENT T-PATCH NOTES:**

**1. GENERAL:**

- A. VERTICAL CUTS IN BITUMINOUS PAVEMENT MAY BE DONE BY SAW OR PAVEMENT ZIPPING. IF CUTS GREATER THAN 6 INCHES ARE NECESSARY TO PREVENT PAVEMENT "BREAK OFF" CONSULT CITY ENGINEER FOR DIRECTION ON HANDLING ADDITIONAL COSTS.
- B. REPAIR A T-PATCH RESTORATION IF ANY OF THE FOLLOWING CONDITIONS OCCUR PRIOR TO FINAL PAYMENT OR AT THE END OF THE ONE YEAR CORRECTION PERIOD:
  - 1) PAVEMENT SURFACE DISTORTION EXCEEDS 1/4-INCH DEVIATION IN 10 FEET.  
REPAIR OPTION - PLANE OFF SURFACE DISTORTIONS. COAT PLANED SURFACE WITH A CATIONIC OR ANIONIC MULSION THAT COMPLIES WITH APWA SECTION 32 12 03.
  - 2) SEPARATION APPEARS AT A CONNECTION TO AN EXISTING PAVEMENT OR ANY STREET FIXTURE.  
REPAIR OPTION - BLOW SEPARATION CLEAN AND APPLY JOINT SEALANT, PLAN 265.
  - 3) CRACKS AT LEAST 1-FOOT LONG AND 1/4-INCH WIDE OCCUR MORE OFTEN THAN 1 IN 10 SQUARE FEET.  
REPAIR OPTION - BLOW CLEAN AND APPLY CRACK SEAL, PLAN 265.
  - 4) PAVEMENT RAVELING IS GREATER THAN 1 SQUARE FOOT PER 100 SQUARE FEET.  
REPAIR OPTION - MILL AND INLAY, APWA SECTIONS 32 01 16.71 AND 32 12 05.

**2. PRODUCTS:**

- A. BASE COURSE: UNTREATED BASE COURSE, APWA SECTION 32 11 23. DO NOT USE GRAVEL AS A BASE COURSE WITHOUT ENGINEER'S PERMISSION.
- B. FLOWABLE FILL: TARGET IS 60 PSI IN 28 DAYS WITH 90 PSI MAXIMUM IN 28 DAYS, APWA SECTION 31 05 15. IT MUST FLOW EASILY REQUIRING NO VIBRATION FOR CONSOLIDATION.
- C. REINFORCEMENT: NO. 5 GALVANIZED OR EPOXY COATED, DEFORMED, 60 KSI YIELD GRADE STEEL, ASTM A615.
- D. CONCRETE: CLASS 4000, APWA SECTION 03 30 04.
- E. TACK COAT: APWA SECTION 32 12 05.
- F. BITUMINOUS CONCRETE: APWA SECTION 32 12 05.
  - 1) WARM WEATHER PATCH: PG64-22-DM-1/2, UNLESS INDICATED OTHERWISE.
  - 2) COLD WEATHER PATCH: MODIFIED MC-250-FM-1 AS INDICATED IN APWA SECTION 33 05 25.

**3. EXECUTION:**

- A. BASE COURSE PLACEMENT: APWA SECTION 32 05 10. MAXIMUM LIFT THICKNESS BEFORE COMPACTION IS 8-INCHES WHEN USING RIDING EQUIPMENT OR 6-INCHES WHEN USING HAND HELD EQUIPMENT. COMPACTION IS 95 PERCENT OR GREATER RELATIVE TO A MODIFIED PROCTOR DENSITY, APWA SECTION 31 23 26.
- B. FLOWABLE FILL: CURE TO INITIAL SET BEFORE PLACING AGGREGATE BASE OR BITUMINOUS PAVEMENT. USE IN EXCAVATIONS THAT ARE TOO NARROW TO RECEIVE COMPACTION EQUIPMENT.
- C. TACK COAT: CLEAN ALL HORIZONTAL AND VERTICAL SURFACES. APPLY FULL COVERAGE ALL SURFACES.
- D. PAVEMENT PLACEMENT: FOLLOW APWA SECTION 32 12 16.13. UNLESS INDICATED OTHERWISE, LIFT THICKNESS IS 3-INCHES MINIMUM AFTER COMPACTION. COMPACT TO 94 PERCENT OF ASTM D2041 (RICE DENSITY) PLUS OR MINUS 2 PERCENT.
- E. BITUMINOUS CONCRETE SUBSTITUTION: IF BITUMINOUS CONCRETE IS SUBSTITUTED FOR PORTLAND CEMENT CONCRETE SUBSTRATE, OMIT REBAR AND PROVIDE 1.25 INCHES OF BITUMINOUS CONCRETE FOR EACH 1 INCH OF PORTLAND CEMENT CONCRETE. FOLLOW PARAGRAPH E REQUIREMENTS.
- F. REINFORCEMENT: REQUIRED IF THICKNESS OF EXISTING PORTLAND-CEMENT CONCRETE SUBSTRATE IS 6-INCHES OR GREATER. NOT REQUIRED IF:
  - 1) LESS THAN 6-INCHES THICK,
  - 2) IF EXISTING CONCRETE IS DETERIORATING,
  - 3) IF EXCAVATION IS LESS THAN 3 FEET SQUARE, OR
  - 4) IF BITUMINOUS PAVEMENT IS SUBSTITUTED FOR PORTLAND-CEMENT CONCRETE SUBSTRATE.
- G. CONCRETE SUBSTRATE: CURE TO INITIAL SET BEFORE PLACING NEW BITUMINOUS CONCRETE PATCH.

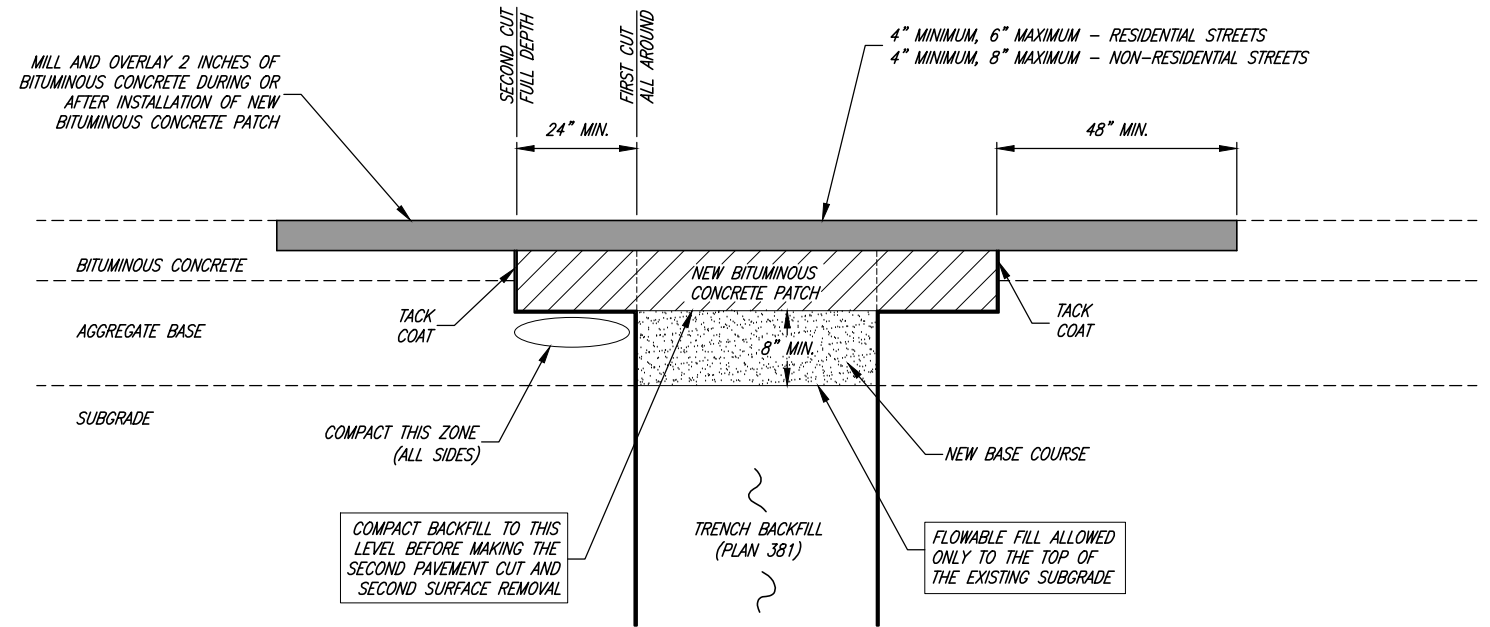

**BITUMINOUS CONCRETE RESTORATION**

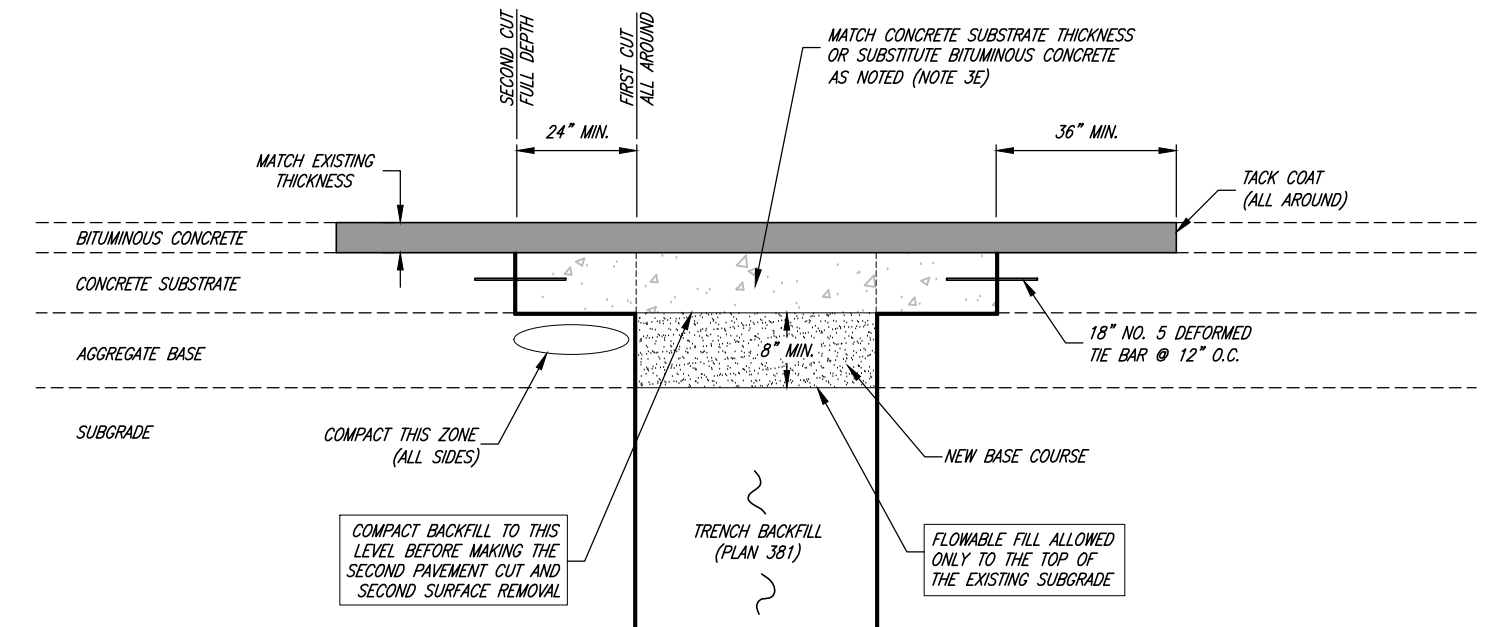

**COMPOSITE RESTORATION**



**Bituminous pavement T-patch**

Plan  
**255**  
November 2015



BRANDON KENT JONES  
No. 5148758  
PROJECT ENGINEER  
11/28/2023  
DATE

REV.	DATE	APPR.

SCALE:  
N. T. S.  
DESIGNED BKJ  
DRAWN BEB  
CHECKED BKJ



**CONSULTING ENGINEERS**  
6080 Fashion Point Drive  
South Ogden, Utah 84403 (801) 476-9767  
www.jonescivil.com



**SOUTH WEBER CITY CORPORATION**  
PUBLIC WORKS - ROAD IMPROVEMENT STANDARDS  
**APWA PLAN 255 BITUMINOUS PAVEMENT T-PATCH**

SHEET:  
**R12**  
OF 34 SHEETS  
0

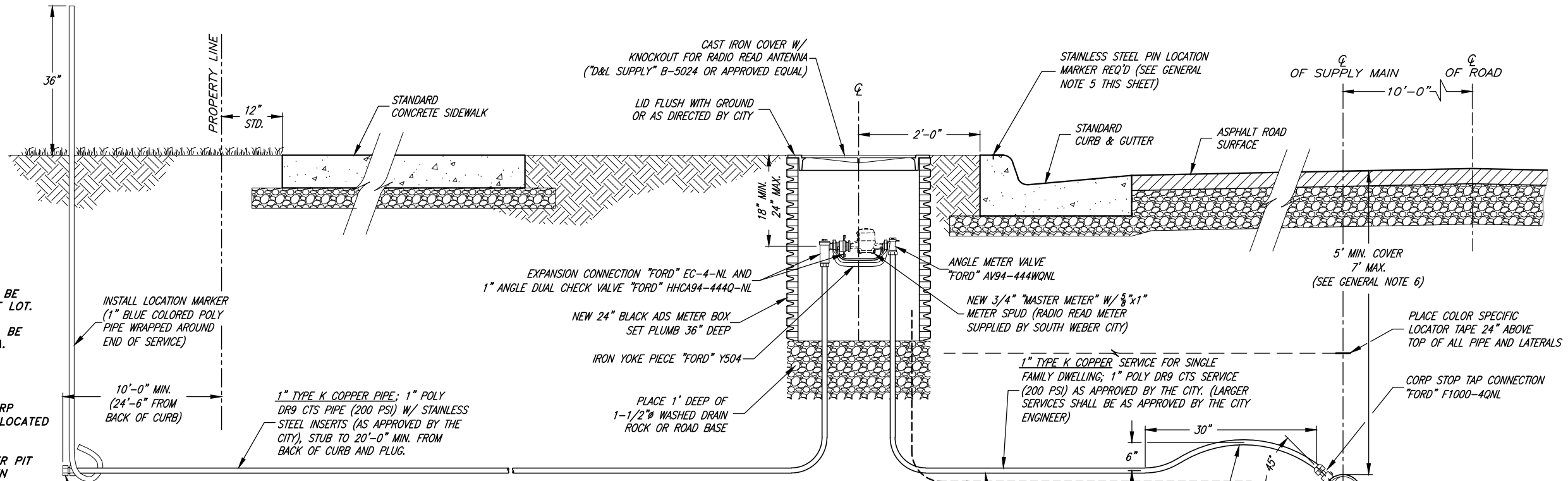

**METER LOCATION NOTES:**

1. ALL CULINARY WATER METERS SHALL BE CENTERED ON THE FRONTAGE OF THE LOT.
2. CULINARY WATER METERS SHALL NOT BE LOCATED WITHIN THE DRIVEWAY AREA.
3. IF A DRIVEWAY IS PLACED OVER AN EXISTING METER:
  - a. THE "ENTIRE" SERVICE LINE, CORP STOP, AND METER SHALL BE RELOCATED AT THE OWNER'S EXPENSE, OR
  - b. HIGH TRAFFIC RESIDENTIAL METER PIT MAY BE INSTALLED WITH WRITTEN APPROVAL FROM THE CITY WATER DIVISION. THIS IS DETERMINED ON A CASE BY CASE BASIS BY THE CITY WATER DIVISION AND TO BE PAID FOR BY THE OWNER.

**RESIDENTIAL WATER SERVICE AND METER**

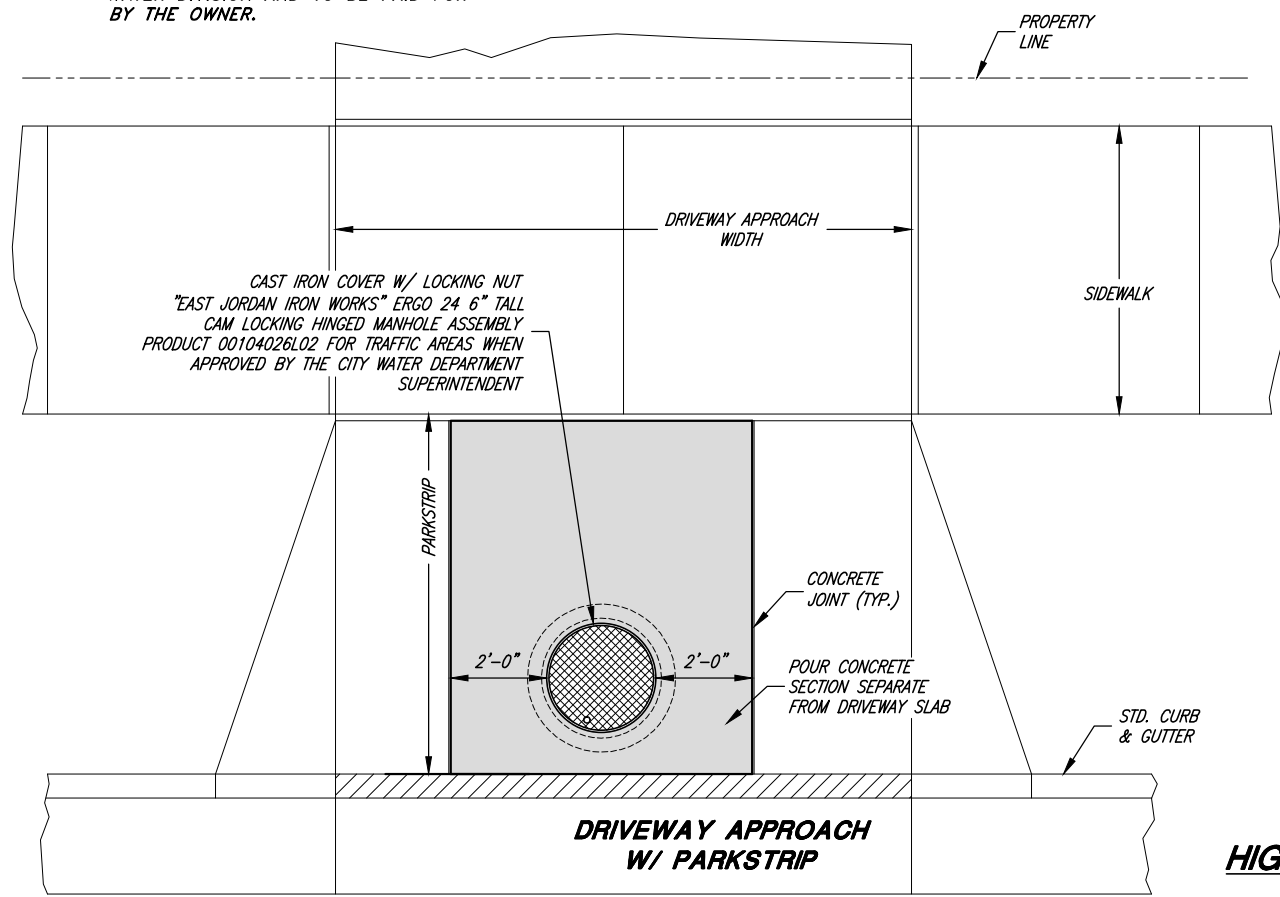

**HIGH TRAFFIC RESIDENTIAL METER PIT DETAIL**

THE USE OF A HIGH TRAFFIC RESIDENTIAL SERVICE METER PIT IS SITE SPECIFIC AND REQUIRES WRITTEN APPROVAL FROM THE WATER SYSTEM SUPERINTENDENT PRIOR TO INSTALLATION

CAST IRON COVER W/ LOCKING NUT AND KNOCKOUT FOR RADIO READ ANTENNA. ("EAST JORDAN IRON WORKS" ERGO 24 6" TALL CAM LOCKING HINGED MANHOLE ASSEMBLY PRODUCT 00104026L02 FOR TRAFFIC AREAS WHEN APPROVED BY THE CITY WATER SYSTEM SUPERINTENDENT)

**C900** - CITY STANDARD (UNLESS OTHERWISE SPECIFIED) BLUE COLOR PIPE W/ BLUE 12 GAUGE TRACER WIRE. 8"-12" MAINS SHALL BE C900 DR-18 14" OR LARGER MAINS SHALL BE C900 DR-18  
 DUCTILE IRON PIPE IS ALSO ALLOWED BY THE CITY - POLYWRAP ALL D.I. WATERLINES 8"-12" MAINS SHALL BE CLASS 51. 14" OR LARGER MAINS SHALL BE CLASS 250 psi

- GENERAL NOTES:**
1. ALL FITTINGS SHALL BE "MUELLER" COMPRESSION TYPE UNLESS OTHERWISE NOTED.
  2. "BLUE" BOLTS AND NUTS ARE REQUIRED BY THE CITY.
  3. ALL SUPPLIES, LABOR, MACHINERY, ETC. WILL BE SUPPLIED BY THE CONTRACTOR. SOUTH WEBER CITY WILL SUPPLY AND SET THE METER ONLY ON 1" CONNECTIONS. THE CONTRACTOR SHALL SUPPLY METERS FOR CONNECTIONS GREATER THAN 1" (SEE SHEET CW4).
  4. ALL SPECIFIED BRANDS OF MATERIALS SHOWN ON THESE DRAWINGS ARE "CITY STANDARDS." OTHER EQUIVALENT BRANDS MAY BE USED WITH PRIOR APPROVAL OF THE CITY ENGINEER AND THE CITY WATER SYSTEM SUPERINTENDENT.
  5. STAMPED STAINLESS STEEL PINS USED FOR LATERAL LOCATING ARE REQUIRED BY THE CITY. BLANK S.S. PINS SHALL BE PROVIDED BY THE CITY AND INSTALLED AND STAMPED BY THE CONTRACTOR DURING ALL NEW CONSTRUCTION OR RESTORED WHEN REPLACING DAMAGED CURB & GUTTER DUE TO ANY CONSTRUCTION RELATED ACTIVITY. S.S. PINS SHALL BE STAMPED "S" FOR SANITARY SEWER, "W" FOR CULINARY WATER, AND "L" FOR LAND DRAIN.
  6. ALL CULINARY WATER MAINS AND SERVICES MUST MAINTAIN A MINIMUM SEPARATION ABOVE ALL SEWER MAINS AND LATERALS OF 18" VERTICAL AND 10'-0" HORIZONTAL IN ACCORDANCE WITH THE STATE OF UTAH DIVISION OF DRINKING WATER (DDW) RULES SECTION R309-550-7. EXCEPTIONS MUST BE APPROVED BY DDW.



BRANDON K. JONES  
 PROJECT ENGINEER  
 11/28/2023  
 DATE

REV.	DATE	APPR.

SCALE: N. T.S.  
 DESIGNED: BKJ  
 DRAWN: BEB  
 CHECKED: BKJ



**CONSULTING ENGINEERS**  
 6080 Fashion Point Drive  
 South Ogden, Utah 84403 (801) 476-9767  
 www.jonescivil.com

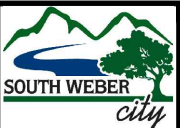

**SOUTH WEBER CITY CORPORATION**  
 PUBLIC WORKS - CULINARY WATER SYSTEM STANDARDS  
**RESIDENTIAL WATER SERVICE CONNECTION DETAILS**

SHEET: **CW1**  
 OF 34 SHEETS  
 0



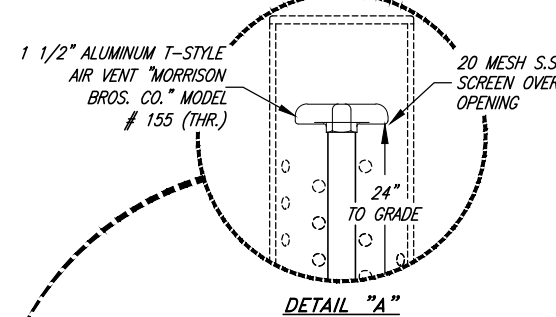
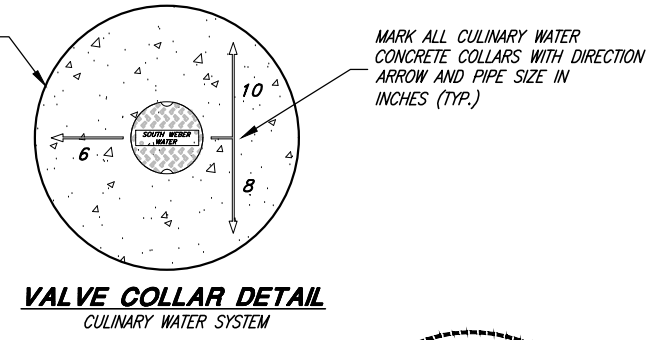
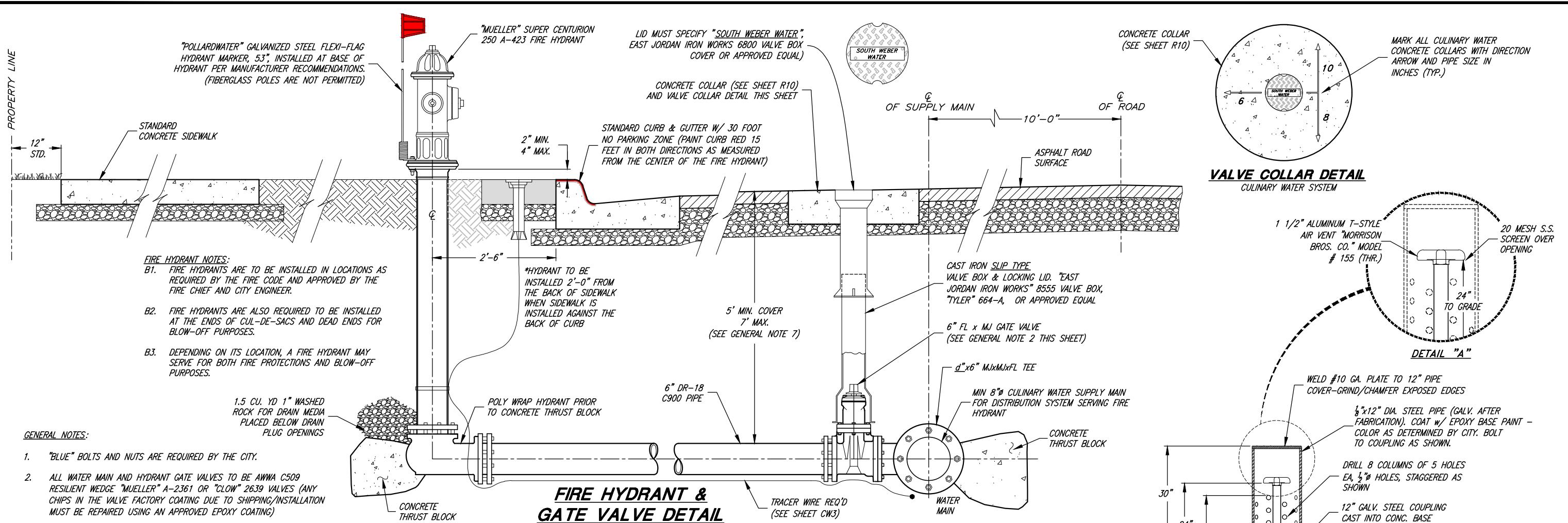

**FIRE HYDRANT & GATE VALVE DETAIL**

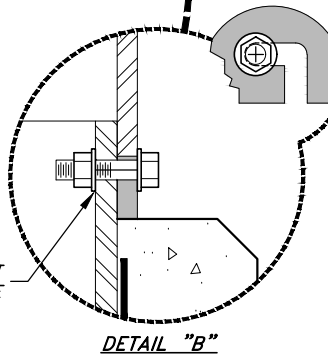
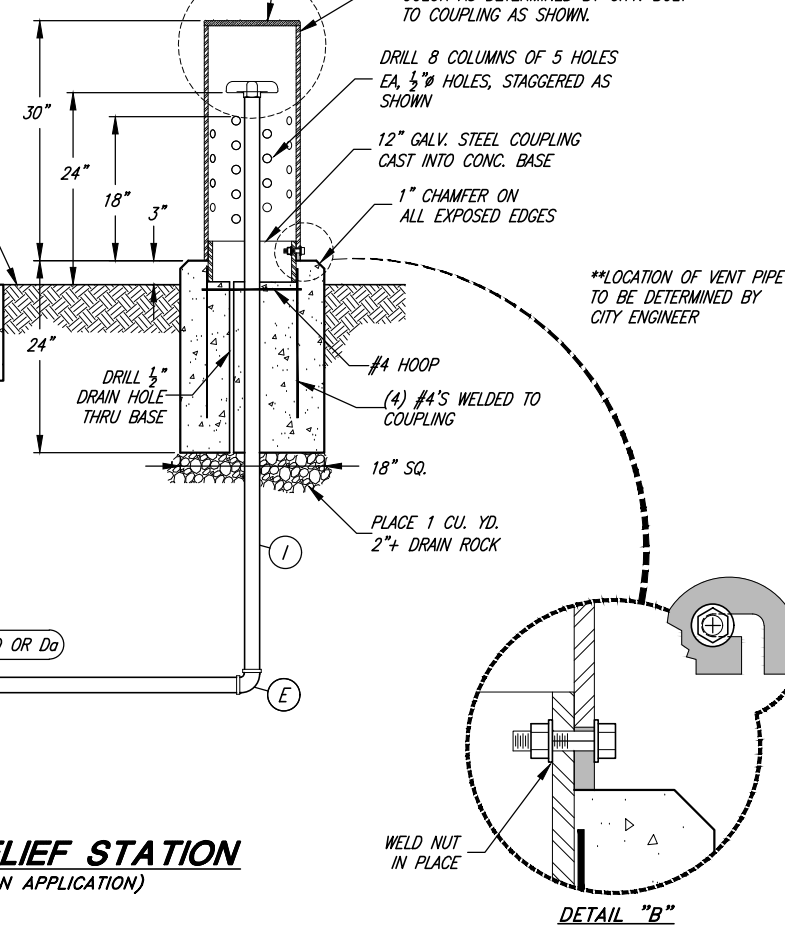

- FIRE HYDRANT NOTES:**
- B1. FIRE HYDRANTS ARE TO BE INSTALLED IN LOCATIONS AS REQUIRED BY THE FIRE CODE AND APPROVED BY THE FIRE CHIEF AND CITY ENGINEER.
  - B2. FIRE HYDRANTS ARE ALSO REQUIRED TO BE INSTALLED AT THE ENDS OF CUL-DE-SACS AND DEAD ENDS FOR BLOW-OFF PURPOSES.
  - B3. DEPENDING ON ITS LOCATION, A FIRE HYDRANT MAY SERVE FOR BOTH FIRE PROTECTIONS AND BLOW-OFF PURPOSES.

- GENERAL NOTES:**
1. "BLUE" BOLTS AND NUTS ARE REQUIRED BY THE CITY.
  2. ALL WATER MAIN AND HYDRANT GATE VALVES TO BE AWWA C509 RESILIENT WEDGE "MUELLER" A-2361 OR "CLOW" 2639 VALVES (ANY CHIPS IN THE VALVE FACTORY COATING DUE TO SHIPPING/INSTALLATION MUST BE REPAIRED USING AN APPROVED EPOXY COATING)
  3. ALL SPECIFIED BRANDS OF MATERIALS SHOWN ON THESE DRAWINGS ARE "CITY STANDARDS." OTHER EQUIVALENT BRANDS MAY BE USED WITH PRIOR APPROVAL OF THE CITY ENGINEER AND THE CITY WATER SYSTEM SUPERINTENDENT.
  4. PIPES, JOINTS, FITTINGS, VALVES, & FIRE HYDRANTS SHALL CONFORM TO ANSI / NSF 61.
  5. FIRE HYDRANTS SHALL NOT BE LOCATED WITHIN 10 FEET OF A SANITARY SEWER OR WITHIN 10 FEET OF STORM DRAIN WHERE POSSIBLE.
  6. ALL WATER SYSTEM MATERIALS SHALL BE NEW; USED MATERIALS ARE NOT ALLOWED.
  7. ALL CULINARY WATER MAINS AND SERVICES MUST MAINTAIN A MINIMUM SEPARATION ABOVE ALL SEWER MAINS AND LATERALS OF 18" VERTICAL AND 10'-0" HORIZONTAL IN ACCORDANCE WITH THE STATE OF UTAH DIVISION OF DRINKING WATER (DDW) RULES SECTION R309-550-7. EXCEPTIONS MUST BE APPROVED BY DDW.

- AIR/VACUUM RELIEF STATION NOTES:**
- A1. THE USE OF AN "APCO" MODEL 145C OR "VAL-MATIC" MODEL 202C COMBINATION AIR/VACUUM VALVE IS ACCEPTED WHEN APPROVED BY THE CITY WATER DEPARTMENT SUPERINTENDENT. UPSIZE VENT PIPE, AIR VENT AND FITTINGS (ITEMS D, E, F, H AND I) TO 2" DIA. AND GALVANIZED WHEN USING ALTERNATE VALVES.
  - A2. NO MORE THAN 12" OF GRADE RINGS TO BE ALLOWED ON ANY MANHOLE

**PIPE & FITTING SCHEDULE**

NO.	DESCRIPTION	FITTING
A	2" COMBINATION AIR-VACUUM RELIEF VALVE	THR.
B	"A.R.I." MODEL D-040 W/ NPT CONNECTIONS	THR.
C	2" BRASS BALL VALVE (1/4 TURN)	THR.
D	2" BRASS DOUBLE S.S. STRAPS SERVICE SADDLE	THR.
D <sub>a</sub>	1 1/2" SCH. 80 PVC PIPE	THR.
E	1 1/2" POLY PIPE	THR.
F	1 1/2" GALV. STEEL 90° ELBOW	THR.
G	1 1/2" SCH. 80 PVC UNION	THR.
H	2" BRASS PIPE	THR.
I	1 1/2" SCH. 80 PVC TEE	THR.
I	1 1/2" GALV. STEEL PIPE	THR.

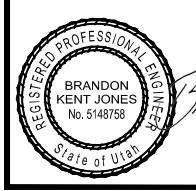

BRANDON K. JONES  
PROJECT ENGINEER  
11/28/2023  
DATE

REV.	DATE	APPR.

SCALE:  
N. T.S.

DESIGNED BKJ  
DRAWN BEB  
CHECKED BKJ

**JA JONES & ASSOCIATES**  
CONSULTING ENGINEERS  
6080 Fashion Point Drive  
South Ogden, Utah 84403 (801) 476-9767  
www.jonescivil.com

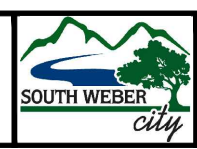

**SOUTH WEBER CITY CORPORATION**  
PUBLIC WORKS - CULINARY WATER SYSTEM STANDARDS  
**FIRE HYDRANT, GATE VALVE, AND AIR/VACUUM RELIEF STATION DETAILS**

SHEET:  
**CW2**  
OF 34 SHEETS  
0



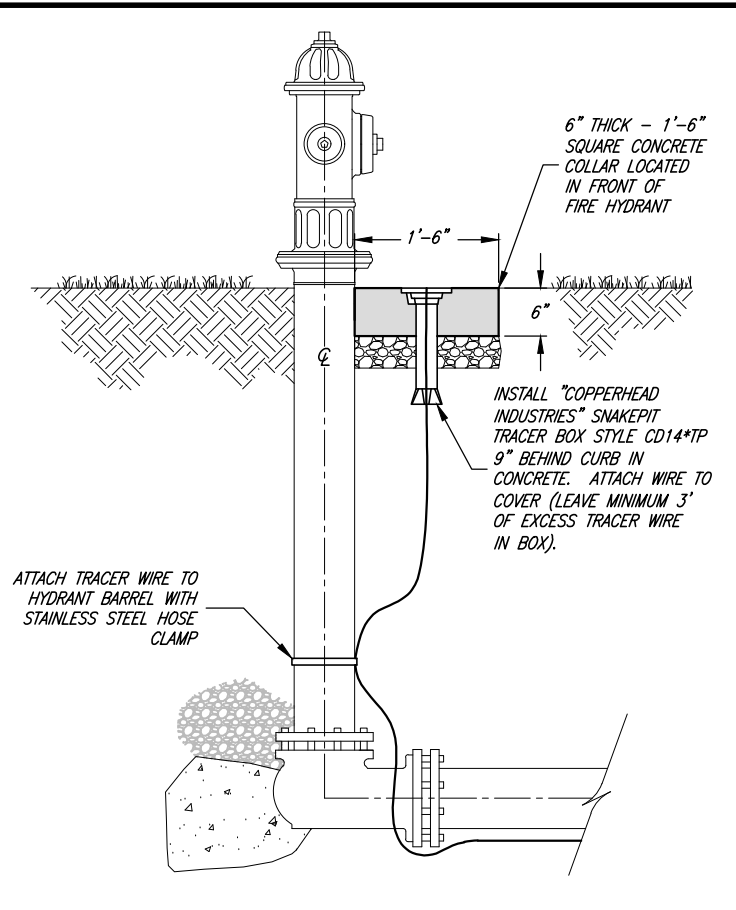
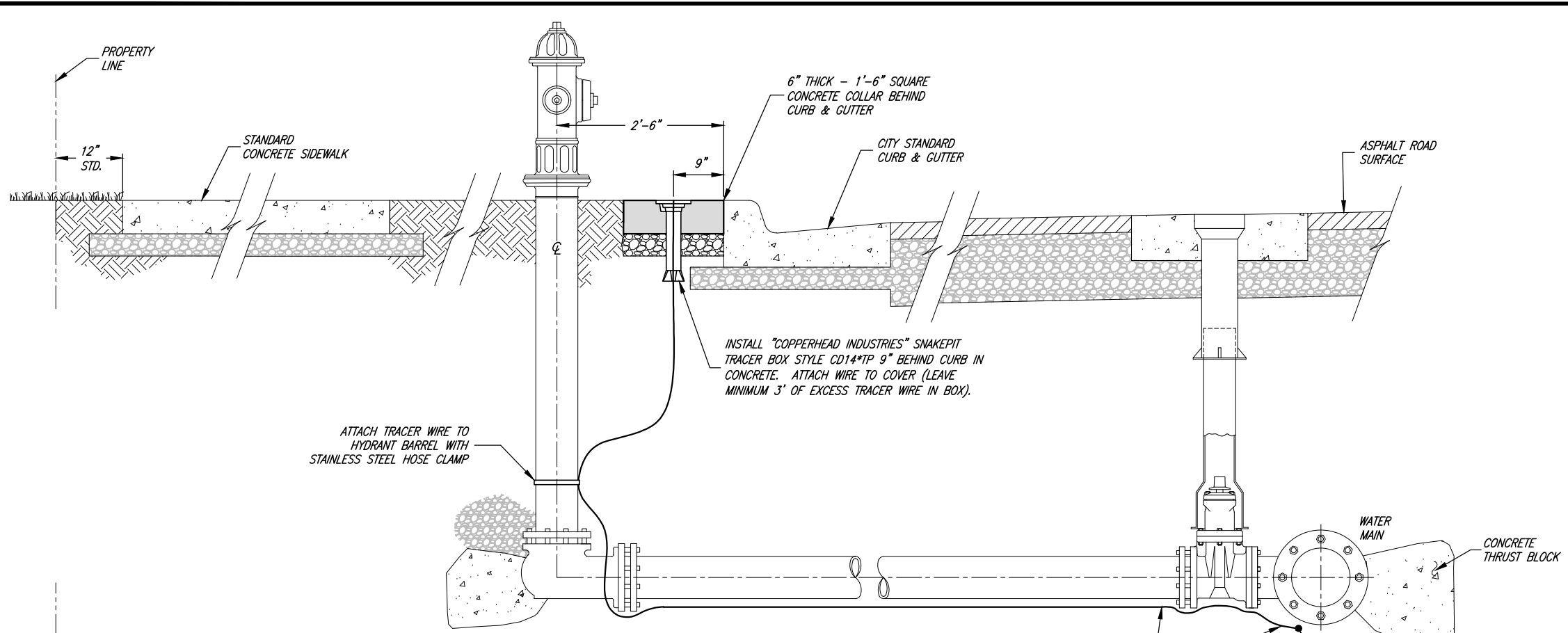

**ALTERNATE TRACER WIRE INSTALLATION**

WHERE APPROVED BY THE WATER SYSTEM SUPERINTENDENT ON STREET SECTIONS WITH NO CURB & GUTTER

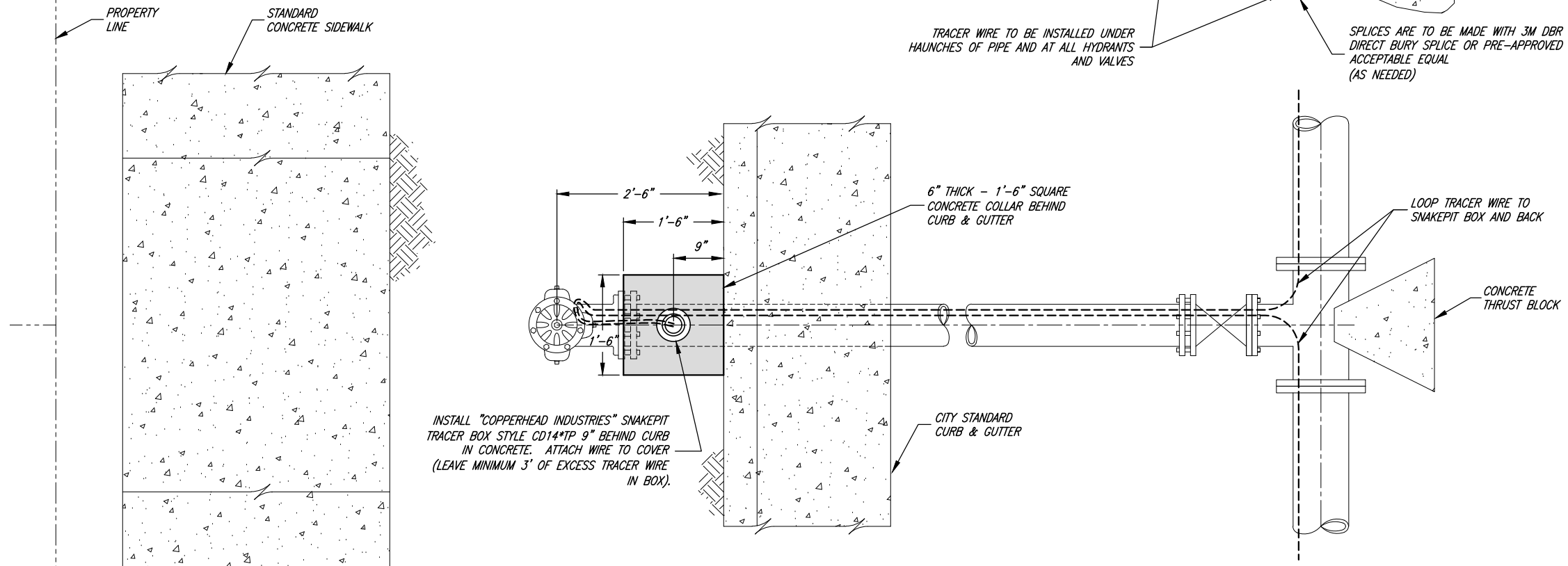

**TRACER WIRE INSTALLATION**

CITY STANDARD STREET SECTION (CURB & GUTTER)

NOTES:

1. ALL WATERLINES SHALL HAVE A MINIMUM 12 GA. INSULATED TRACER WIRE INSTALLED UNDER THE HAUNCHES OF THE PIPE PRIOR TO BACKFILLING.
2. TRACER WIRES SHALL TERMINATE AT ALL FIRE HYDRANTS. AT SERVICE SADDLES AND TAPPING SLEEVES, THE TRACER WIRE SHALL NOT BE ALLOWED TO BE PLACED BETWEEN THE SADDLE AND THE PIPE. A GROUNDING ROD SHALL BE INSTALLED AT ALL TRACER SYSTEM TERMINAL POINTS.
3. TRACER WIRE SHALL BE COPPER WIRE WITH BLUE INSULATION RATED FOR DIRECT BURIAL. ALL WIRE CONNECTORS SHALL BE 3M DBR DIRECT BURY SPLICE OR PRE-APPROVED ACCEPTABLE EQUAL AND SHALL BE WATERTIGHT TO PROVIDE ELECTRICAL CONTINUITY.
4. ALL TRACER WIRE SHALL BE TESTED FOR CONTINUITY IN THE PRESENCE OF THE PUBLIC WORKS INSPECTOR PRIOR TO ASPHALT PLACEMENT. ANY TRACER WIRE FOUND NOT TO BE CONTINUOUS AFTER TESTING SHALL BE REPAIRED OR REPLACED BY THE CONTRACTOR PRIOR TO ASPHALT PLACEMENT.



BRANDON KENT JONES  
No. 5148758  
PROJECT ENGINEER  
11/28/2023  
DATE

REV.	DATE	APPR.

SCALE:  
N. T.S.  
DESIGNED *BKJ*  
DRAWN *BEB*  
CHECKED *BKJ*



**CONSULTING ENGINEERS**  
6080 Fashion Point Drive  
South Ogden, Utah 84403 (801) 476-9767  
www.jonescivil.com

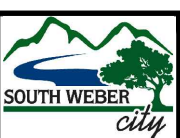

**SOUTH WEBER CITY CORPORATION**  
PUBLIC WORKS - CULINARY WATER SYSTEM STANDARDS  
**TRACER WIRE INSTALLATION DETAILS**

SHEET:  
**CW3**  
OF 34 SHEETS  
0

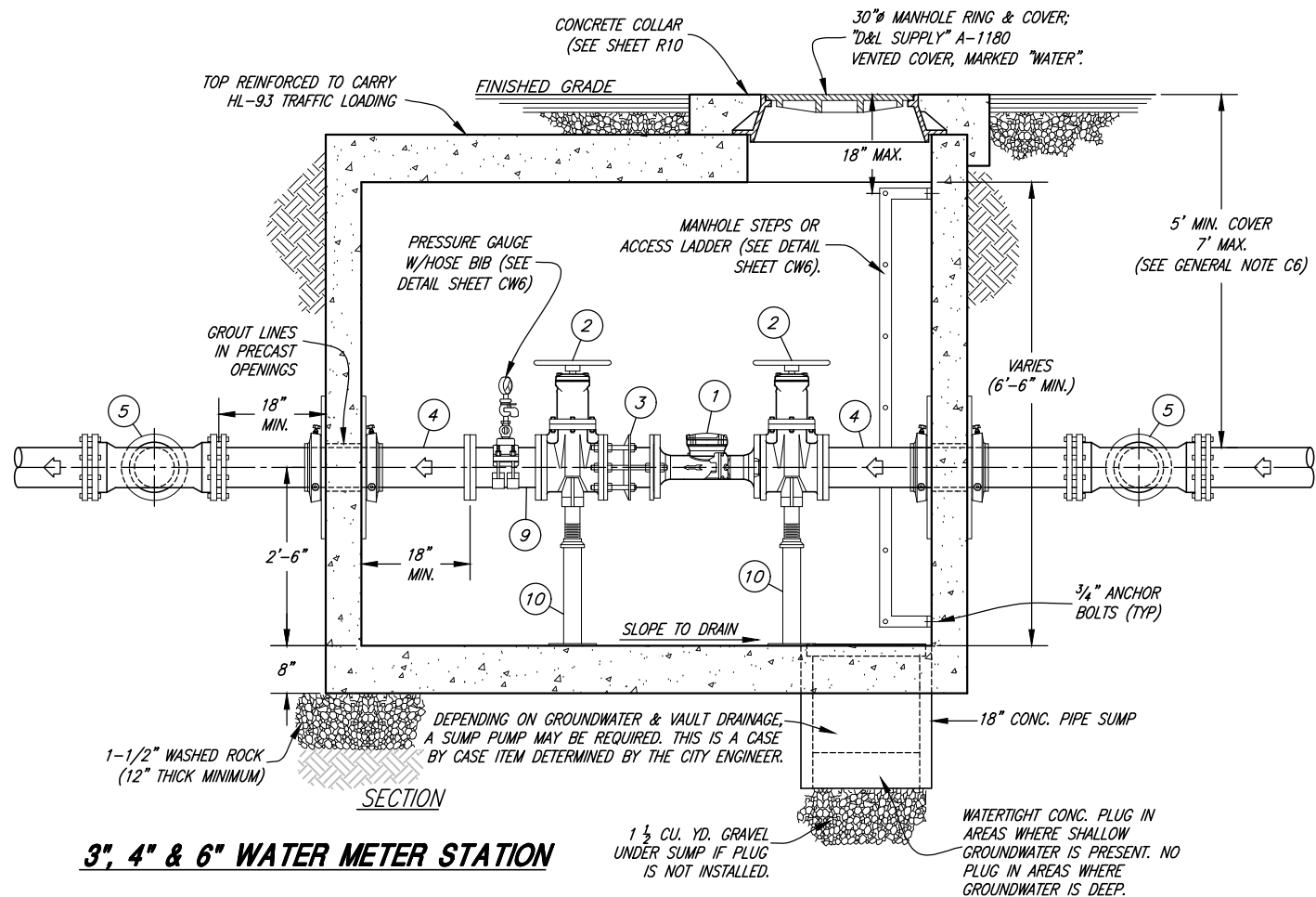
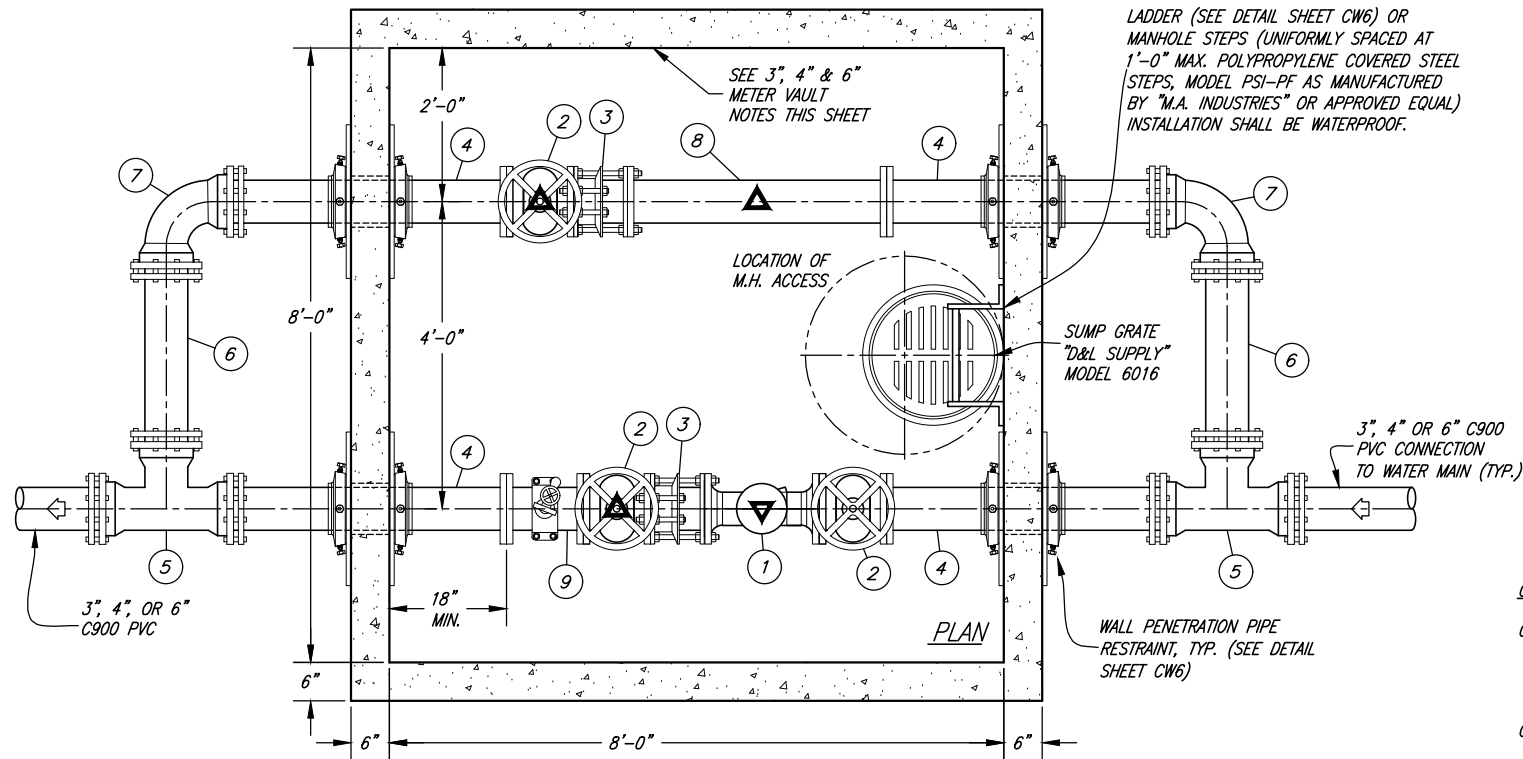

**3", 4" & 6" WATER METER STATION**

**3", 4" & 6" METER VAULT NOTES:**

- A1. ALL FITTINGS OUTSIDE OF THE VAULT ARE TO BE DUCTILE IRON MJ WITH THRUST RESTRAINT RETAINER GLANDS ("ROMAC", MJRG, OR APPROVED EQUAL)
- A2. PENETRATION WALLS NEED TO BE ADEQUATELY DESIGNED STRUCTURALLY FOR ANTICIPATED THRUST.
- A3. THE PRECAST VAULT MANUFACTURER IS RESPONSIBLE FOR DESIGN RELATED TO TRAFFIC LOADING AND THRUST. VERIFICATION OF PROPER DESIGN MUST BE PROVIDED TO THE CITY BY THE DEVELOPER, CONTRACTOR, OR PROPERTY OWNER AS THE CASE MAY BE.
- A4. ALL FITTINGS SHALL BE AWWA C-110 WITH 125 LB. FLANGES. ALL PIPING SHALL BE DUCTILE IRON PIPE CLASS 350 P.S.I. MIN.

NOTE:  
ALL SPECIFIED BRANDS OF MATERIALS SHOWN ON THESE DRAWINGS ARE "CITY STANDARDS." OTHER EQUIVALENT BRANDS MAY BE USED WITH PRIOR APPROVAL OF THE CITY ENGINEER AND THE CITY WATER SYSTEM SUPERINTENDENT.

**GENERAL NOTES:**

- C1. PROPERTY OWNER OR CONTRACTOR SHALL PAY FOR ALL COSTS OF INSTALLATION INCLUDING ALL MATERIALS, ALL EXCAVATION AND FILL, ASPHALT REPLACEMENT AND WATER MAIN CONNECTION.
- C2. INSPECTION OF ALL WATER LINE INSTALLATIONS WILL BE DONE BY THE CITY WATER DEPARTMENT, WITH A 48 HOUR MINIMUM NOTICE REQUIRED PRIOR TO START OF WORK.
- C3. IF APPLICABLE, A CITY EXCAVATION PERMIT MUST BE REQUESTED AND APPROVED PRIOR TO START OF WORK.
- C4. "BLUE" BOLTS AND NUTS ARE REQUIRED BY THE CITY.
- C5. CONTRACTOR TO SUPPLY ALL METERS 1 1/2" OR LARGER.
- C6. ALL CULINARY WATER MAINS AND SERVICES MUST MAINTAIN A MINIMUM SEPARATION ABOVE ALL SEWER MAINS AND LATERALS OF 18" VERTICAL AND 10'-0" HORIZONTAL IN ACCORDANCE WITH THE STATE OF UTAH DIVISION OF DRINKING WATER (DDW) RULES SECTION R309-550-7. EXCEPTIONS MUST BE APPROVED BY DDW.

**1 1/2" & 2" METER NOTES:**

- B1. 1/2" SERVICE LINE-13" METER  
2" SERVICE LINE-17" METER
- B2. NO MORE THAN 12" OF GRADE RINGS TO BE ALLOWED ON ANY MANHOLE
- B3. MANHOLE STEPS (FOR MANHOLES OVER 6' DEEP.) UNIFORMLY SPACED (1'-0" MAX.) POLYPROPYLENE COVERED STEEL STEPS, MODEL PSI-PF AS MANUFACTURED BY "M.A. INDUSTRIES" OR APPROVED EQUAL - STEPS SHALL BE WATERPROOF.

**PIPE & FITTING SCHEDULE**

NO.	DESCRIPTION (3", 4" & 6" METER STA.)	JOINT TYPE	3" LINE	4" LINE	6" LINE
1	"MASTER METER" OCTAVE ULTRASONIC METER W/ 3G INTEGRATED REGISTER	FL	3"	4"	6"
2	"MUELLER" RESILIENT WEDGE GATE VALVE W/ HANDWHEEL (3)	FL	A-2362	A-2361	A-2361
3	"ROMAC" DJ400 DISMANTLING JOINT (2)	FL	3"	4"	6"
4	NIPPLE	FLxPE	3"	4"	6"
5	TEE	MJ	3"	4"	6"
6	PIPE SECTION	PE	3"	4"	6"
7	90° ELBOW	MJ	3"	4"	6"
8	SPOOL PIECE	FL	3"	4"	6"
9	SPOOL PIECE	FL	3"	4"	6"
10	"ANVIL" #264 GALV. PIPE SUPPORT W/ COMPANION FLANGE & VARIABLE HEIGHT NIPPLE (4 EA REQ'D)				

NO.	DESCRIPTION (1 1/2" & 2" METER STA.)	JOINT TYPE	1 1/2" LINE	2" LINE
11	"MASTER METER" INTERMEDIATE MULTI-JET METER W/3G INTEGRATED REGISTER	FL	1 1/2"	2"
12	"MUELLER" B-2423-2 METER YOKE (18" RISER)	-	1 1/2"	2"
13	"MUELLER" 110 COMPRESSION CONN. COUPLING	-	1 1/2"	2"

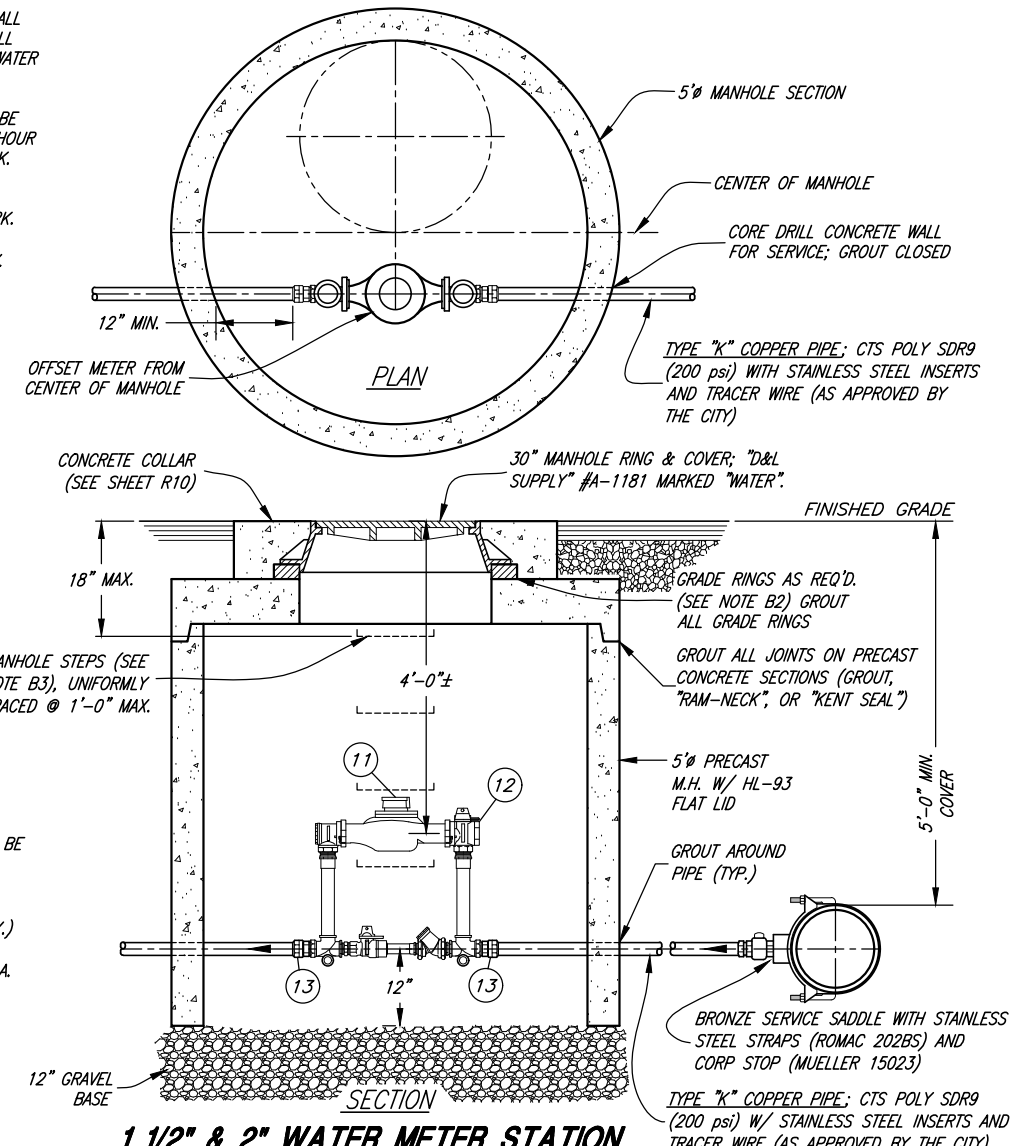

**1 1/2" & 2" WATER METER STATION**



BRANDON KENT JONES  
No. 5148758  
PROJECT ENGINEER  
11/28/2023  
DATE

REV.	DATE	APPR.

SCALE:  
N. T.S.  
DESIGNED: BKJ  
DRAWN: BEB  
CHECKED: BKJ



**CONSULTING ENGINEERS**  
6080 Fashion Point Drive  
South Ogden, Utah 84403 (801) 476-9767  
www.jonescivil.com



**SOUTH WEBER CITY CORPORATION**  
PUBLIC WORKS - CULINARY WATER SYSTEM STANDARDS  
**TYPICAL WATER METER STATIONS**

SHEET:  
**CW4**  
OF 34 SHEETS  
0



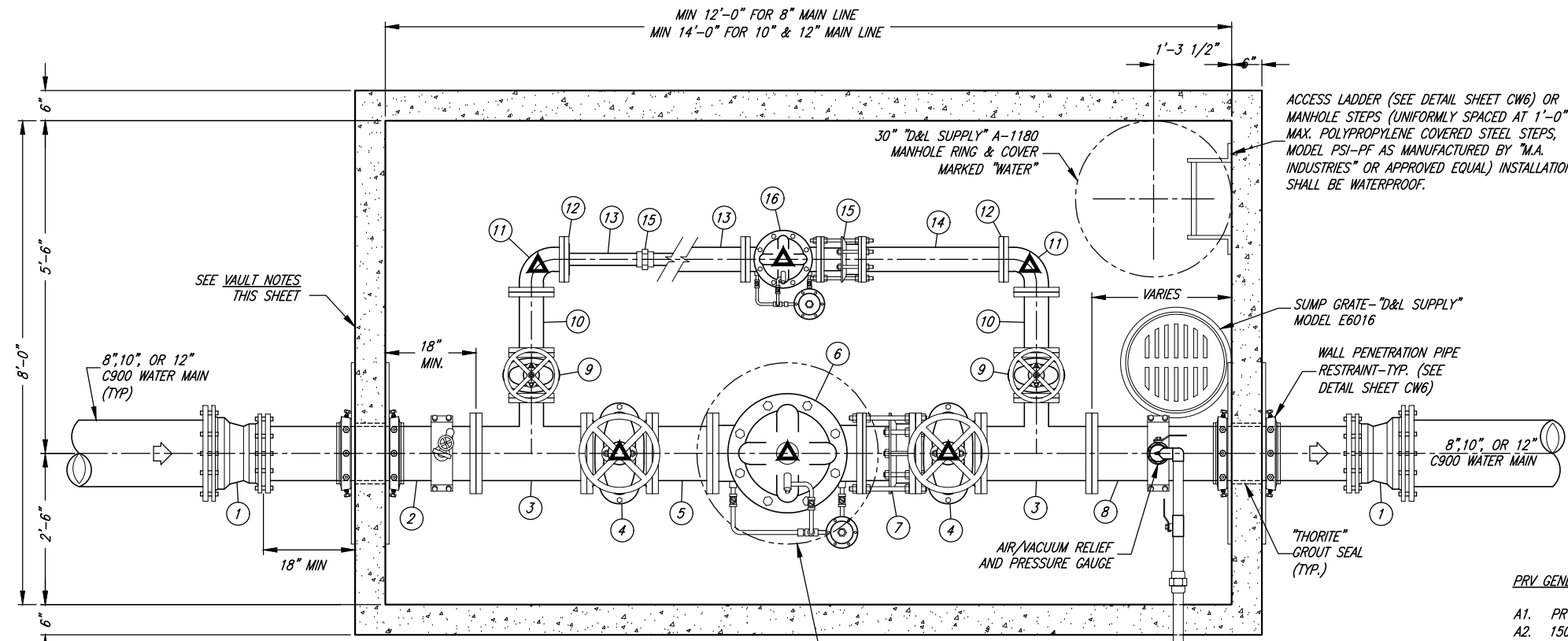

NO.	DESCRIPTION	JOINT TYPE	8" LINE	10" LINE	12" LINE
1	D.I. REDUCER (2)	MxMJ	8"x6"	10"x8"	12"x10"
2	D.I. NIPPLE PIECE	FLxPE	6"	8"	10"
3	D.I. REDUCING TEE (2)	FL	6"x6"x4"	8"x8"x4"	10"x10"x4"
4	"MUELLER" A-2361 GATE VALVE W/ HANDWHEEL (2)	FL	6"	8"	10"
5	12" D.I. SPOOL PIECE	FL	6"	8"	10"
6	"CLA-VAL" 90-01 PRESSURE REDUCTION VALVE	FL	6"	8"	10"
7	"ROMAC" DJ400 DISMANTLING JOINT	FL	6"	8"	10"
8	D.I. NIPPLE PIECE	FLxPE	6"	8"	10"
9	"MUELLER" A-2361 GATE VALVE W/ HANDWHEEL (2)	FL	4"	4"	4"
10	12" D.I. SPOOL PIECE	FL	4"	4"	4"
11	D.I. 90° ELBOW (2)	FL	4"	4"	4"
12	BLIND FLANGE W/ THR. CONNECTION (2)	FLxTHR.	4"x2"	--	--
13	D.I. SPOOL PIECE BRASS PIPE	THR.	--	4"	4"
14	D.I. SPOOL PIECE BRASS PIPE	THR.	--	4"	4"
15	"ROMAC" DJ400 DISMANTLING JOINT BRASS UNION	THR.	--	4"	4"
16	"CLA-VAL" 90-01 PRESSURE REDUCTION VALVE	THR.	--	4"	4"
17	"ANVIL" #264 GALV. PIPE SUPPORT W/ 3" COMPANION FLANGE & VARIABLE HEIGHT 3" NIPPLE (6 EA REQ'D.)	THR.	--	--	--

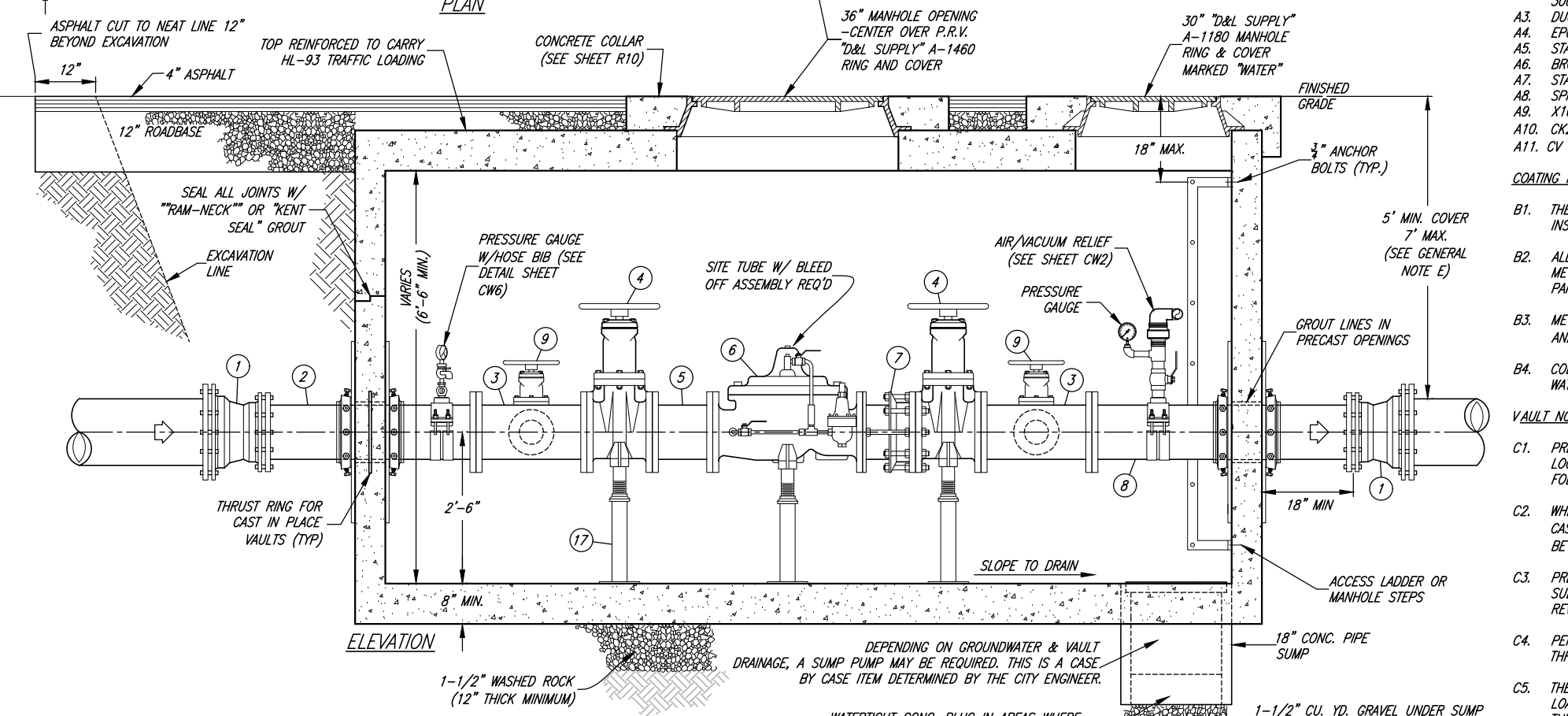

**PRESSURE REDUCTION STATION**

**PRV GENERAL SPECIFICATIONS:**

- A1. PRV TO BE CLA-VAL #90-01 YBCSKC
- A2. 150 # FLANGED FOR 250 PSI WORKING PRESSURE, 300# FLANGED IF GREATER THAN 250 PSI
- A3. DUCTILE IRON BODY GLOBE PATTERN
- A4. EPOXY LINED AND COATED
- A5. STAINLESS STEEL INTERNAL TRIM
- A6. BRONZE PILOT CONTROLS
- A7. STAINLESS STEEL TUBES & FITTINGS
- A8. SPRING RANGES FOR PRESSURE REDUCING PILOT
- A9. X101 VALVE POSITION INDICATOR
- A10. CK2 ISOLATION BALL VALVES (STAINLESS)
- A11. CV FLOW CONTROL (OPENING)

**COATING NOTES:**

- B1. THE P.R.V. VALVE SHALL INCLUDE FACTORY INSTALLED INTERIOR EPOXY COATING.
- B2. ALL NEW AND EXISTING PIPING, VALVES, FITTINGS, METERS, ETC, INSIDE THE VAULT SHALL BE EPOXY PAINTED.
- B3. METAL SURFACES TO BE PAINTED SHALL BE PRIMED AND THEN PAINTED W/ TWO COATS OF EPOXY PAINT.
- B4. COLORS AS DIRECTED BY THE CITY ENGINEER OR CITY WATER SYSTEM SUPERINTENDENT.

**VAULT NOTES:**

- C1. PRE-PLUMBED PRV VAULTS ARE THE PREFERRED OPTION FOR INSTALLATION. THE USE AND LOCATION OF A PRE-PLUMBED PRV VAULT SHALL BE AS DIRECTED BY THE CITY ENGINEER FOLLOWING REVIEW OF CURRENT SITE CONDITIONS.
- C2. WHERE APPLICABLE, PRESSURE RELIEF VALVE ASSEMBLY MAY BE REQUIRED. THIS IS A CASE BY CASE ITEM DETERMINED BY THE CITY WATER DEPARTMENT (PRV VAULT WILL NEED TO BE LENGTHENED TO ACCOMMODATE SUCH VALVE)
- C3. PRECAST CONCRETE STRUCTURE CAN BE REPLACED WITH CAST-IN-PLACE CONCRETE VAULT. SUBMIT ENGINEERED CONSTRUCTION PLANS WITH REBAR DETAILS TO CITY ENGINEER FOR REVIEW AND ACCEPTANCE PRIOR TO CONSTRUCTION.
- C4. PENETRATION WALLS NEED TO BE ADEQUATELY DESIGNED STRUCTURALLY FOR ANTICIPATED THRUST.
- C5. THE PRECAST VAULT MANUFACTURER IS RESPONSIBLE FOR DESIGN RELATED TO HL-93 TRAFFIC LOADING AND THRUST. VERIFICATION OF PROPER DESIGN MUST BE PROVIDED TO THE CITY BY THE DEVELOPER, CONTRACTOR, OR PROPERTY OWNER AS THE CASE MAY BE.

**GENERAL NOTES:**

- A. "BLUE" BOLTS AND NUTS ARE REQUIRED BY THE CITY.
- B. ALL FITTINGS OUTSIDE OF THE VAULT ARE TO BE DUCTILE IRON MJ WITH THRUST RESTRAINT RETAINER GLANDS ("ROMAC", MJRG, OR APPROVED EQUAL)
- C. STRUCTURE, PIPING & VALVE SIZES FOR P.R.V. STATIONS ON LINE SIZES GREATER THAN 12" SHALL BE SPECIFIED BY THE CITY ENGINEER.
- D. ALL SPECIFIED BRANDS OF MATERIALS SHOWN ON THESE DRAWINGS ARE "CITY STANDARDS." OTHER EQUIVALENT BRANDS MAY BE USED WITH PRIOR APPROVAL OF THE CITY ENGINEER AND THE CITY WATER SYSTEM SUPERINTENDENT.
- E. ALL CULINARY WATER MAINS AND SERVICES MUST MAINTAIN A MINIMUM SEPARATION ABOVE ALL SEWER MAINS AND LATERALS OF 18" VERTICAL AND 10'-0" HORIZONTAL IN ACCORDANCE WITH THE STATE OF UTAH DIVISION OF DRINKING WATER (DDW) RULES SECTION R309-550-7. EXCEPTIONS MUST BE APPROVED BY DDW.



BRANDON K. JONES  
PROJECT ENGINEER  
11/28/2023  
DATE

REV.	DATE	APPR.

SCALE:  
N. T.S.  
DESIGNED BKJ  
DRAWN BEB  
CHECKED BKJ

**JA JONES & ASSOCIATES**  
CONSULTING ENGINEERS  
6080 Fashion Point Drive  
South Ogden, Utah 84403 (801) 476-9767  
www.jonescivil.com

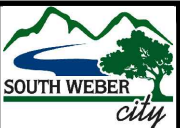

**SOUTH WEBER CITY CORPORATION**  
PUBLIC WORKS - CULINARY WATER SYSTEM STANDARDS  
**PRESSURE REDUCTION STATION**

SHEET:  
**CW5**  
OF 34 SHEETS  
0

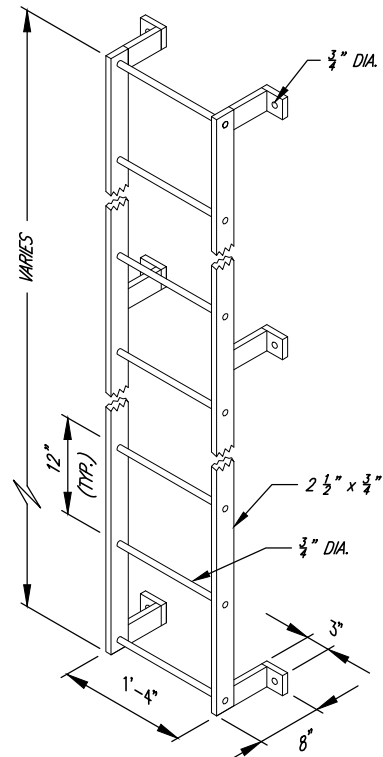

**LADDER DETAIL**

**LADDER NOTES:**

- D1. MAX. 12" SPACING BETWEEN BOTTOM OF LADDER AND VAULT FLOOR.
- D2. HOT DIP GALVANIZE AFTER FABRICATION.

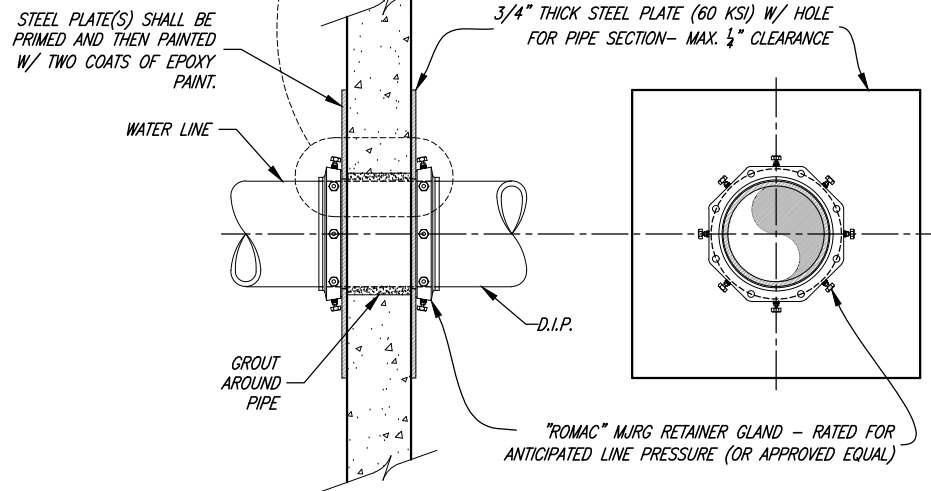
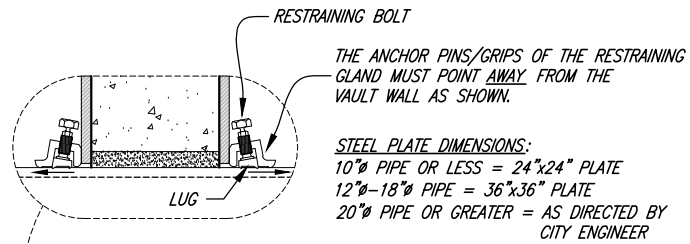

**WALL PENETRATION DETAIL**

FOR PRECAST VAULT (TYP)

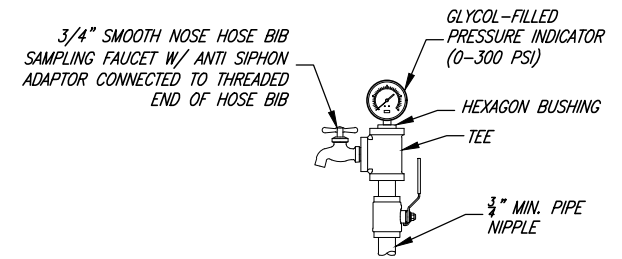

(WITH SAMPLING FAUCET DETAIL)

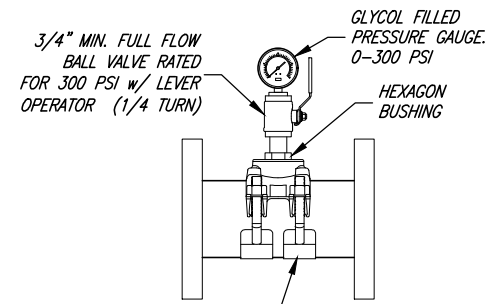

BRASS DOUBLE S.S. STRAPS SERVICE SADDLE OR APPROVED EQUAL

**PRESSURE GAUGE ASSEMBLY**

N.T.S.

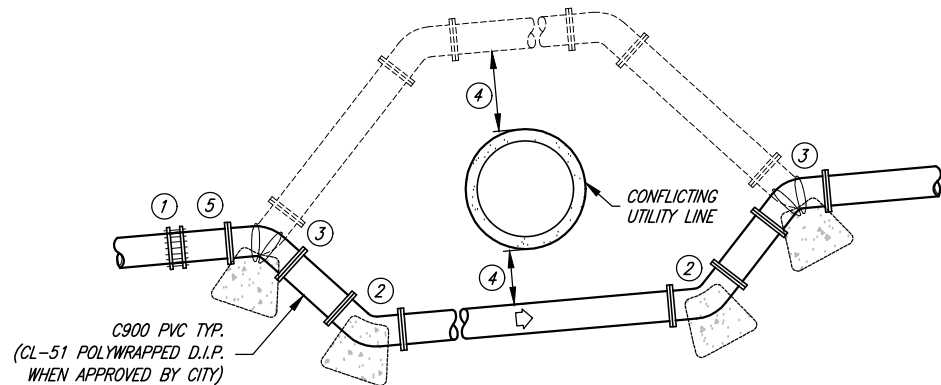

**TYPICAL WATERLINE LOOP**

- 1 TRANSITION COUPLING; "ROMAC" ALPHA, "ROMAC" MACRO, OR APPROVED EQUAL
- 2 MJ 45° BEND W/RETAINER GLANDS
- 3 CONSTRUCT THRUST BLOCKS AT EACH 45° BEND W/(3) #6 REBAR SECURING BLOCK TO FITTING (EPOXY COATING)
- 4 MINIMUM OF 12" COVER BETWEEN THE WATERLINE AND CONFLICTING UTILITY LINE TO BE CROSSED, EXCEPT LOOPS INVOLVING SEWER MAINS WHERE A MINIMUM OF 18" VERTICAL COVER ABOVE THE SEWER MAIN IS REQUIRED. EXCEPTIONS MUST BE APPROVED BY THE UTAH DIVISION OF DRINKING WATER (DDW.)
- 5 AN AIR/VACUUM RELIEF VALVE MAY BE REQUIRED ON A CASE BY CASE BASIS AS DIRECTED BY THE CITY WATER SYSTEM SUPERINTENDENT.

**PIPE RESTRAINT**

- A1. FOR NOMINAL PIPE DIAMETERS 8" AND GREATER, ALL BENDS, CROSSES, TEES, REDUCERS, AND VALVES SHALL BE INSTALLED WITH RESTRAINING JOINTS ("MEGA-LUG", "ALPHA" OR APPROVED EQUAL).
- A2. DESIGN SHALL ALSO BE REQUIRED TO ENSURE ADEQUATE RESTRAINT FOR PIPING JOINTS NEAR FITTINGS BASED ON PIPE DIAMETER AND PIPE PRESSURE.

**THRUST BLOCKING NOTES:**

- B1. CONCRETE SHALL NOT BE PLACED WITHIN 1-1/2" OF JOINTS AND BOLTS. COVER ALL METAL CONTACT AREAS WITH A POLY WRAP PRIOR TO CONCRETE PLACEMENT.
- B2. IN THE ABSENCE OF A SOILS REPORT, ALL THRUST BLOCKS SHALL BE SIZED ON THE BASIS OF A MAXIMUM LATERAL BEARING VALUE FOR 2000 P.S.F. AND A THRUST RESULTING FROM 200% OF THE WATER LINE STATIC LINE TEST.
- B3. THRUST BLOCKS ARE REQUIRED AT ALL BENDS OF 22-1/2" OR MORE. 11-1/4" BENDS SHALL HAVE RETAINER GLANDS.
- B4. CONCRETE SHALL HAVE A MINIMUM COMPRESSIVE STRENGTH OF 3000 PSI IN 28 DAYS.

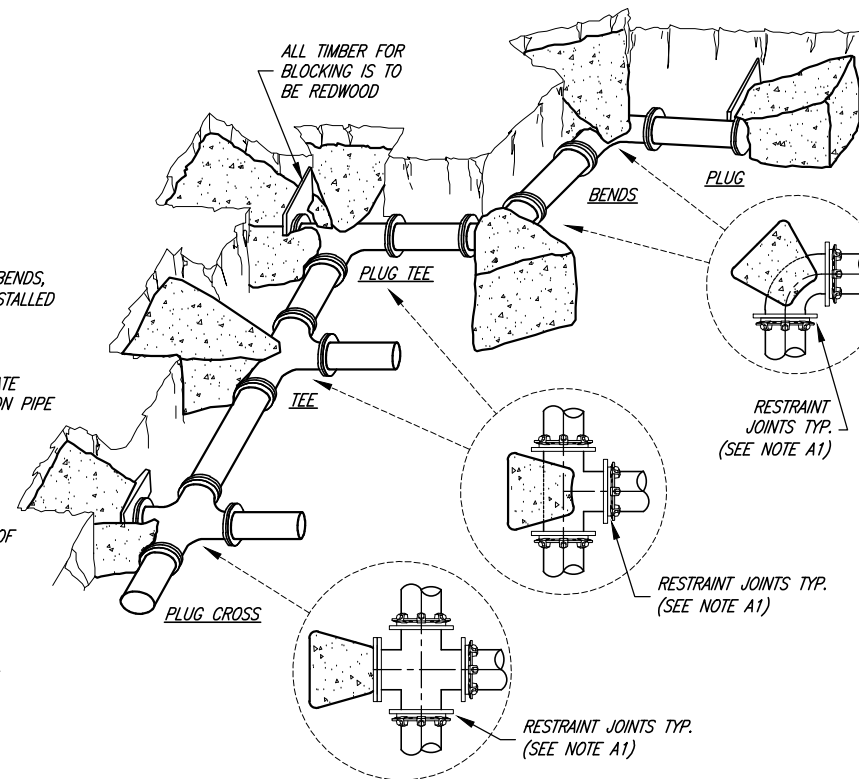

**TYPICAL RETAINER GLANDS & THRUST BLOCKING**

THRUST PER PSI OF WATER PRESSURE AT VARIOUS FITTINGS				
PIPE SIZE (IN.)	DEAD END OR TEE (LB.)	90° ELBOW (LB.)	45° ELBOW (LB.)	22-1/2" ELBOW (LB.)
4	19	27	15	7
6	39	55	30	15
8	67	94	51	26
10	109	154	84	43
12	155	218	119	61
14	210	296	161	82
16	272	383	209	106
18	351	494	269	137
20	434	611	333	169
24	623	878	487	244
30	947	1,332	722	377
36	1,356	1,905	1,032	542

**NOTES:**

- C1. IN USING THE ABOVE TABLE, USE THE MAXIMUM INTERNAL PRESSURE ANTICIPATED (I.E. HYDROSTATIC TEST PRESSURE, POSSIBLE SURGE PRESSURE DUE TO PUMP SHUT OFF, ETC.).
- C2. SEE SOILS REPORT FOR BEARING STRENGTH OF SOIL. IN THE ABSENCE OF A SOILS REPORT, AN AVERAGE SOIL (SPADABLE MEDIUM CLAY) CAN BE ASSUMED TO HAVE A BEARING STRENGTH OF 2000 P.S.F.

**EXAMPLE:**

8-INCH 90° ELBOW, PRESSURE 200 LB./SQ. IN.  
 FROM TABLE: THRUST = 94 X 200 = 18,800 LB.  
 ASSUME BEARING STRENGTH = 2,000 LB./SQ. FT.

$\frac{18,800}{2,000} = 9.4 \text{ SQ. FT. AREA OF BEARING REQUIRED FOR THRUST BLOCK}$



BRANDON KENT JONES  
 PROJECT ENGINEER  
 11/28/2023  
 DATE

REV.	DATE	APPR.

SCALE:  
 N. T.S.

DESIGNED BKJ  
 DRAWN BEB  
 CHECKED BKJ



**CONSULTING ENGINEERS**  
 6080 Fashion Point Drive  
 South Ogden, Utah 84403 (801) 476-9767  
 www.jonescivil.com

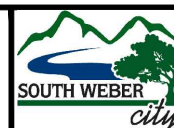

**SOUTH WEBER CITY CORPORATION**  
**PUBLIC WORKS - CULINARY WATER SYSTEM STANDARDS**  
**THRUST BLOCK, WATERLINE LOOP, AND MISC. VAULT DETAILS**

SHEET:  
**CW6**  
 OF 34 SHEETS  
 0



COMMERCIAL DEV. POINT OF CONNECTION	
NO.	DESCRIPTION
B1	WATER SERVICE CONNECTION
B2	CITY STANDARD CULINARY WATER SERVICE METER (SEE SHEET CW1 AND/OR CW4)
B3	GATE VALVE & VALVE BOX STOP & WASTE VALVE AND BOX
B4	BACKFLOW ASSEMBLY (REDUCED PRESSURE ZONE ASSEMBLY)
B5	WATER SERVICE PIPE
B6	QUICK COUPLER/FOR BLOW OUT
B7	MANUAL DRAIN VALVE
B8	MASTER VALVE

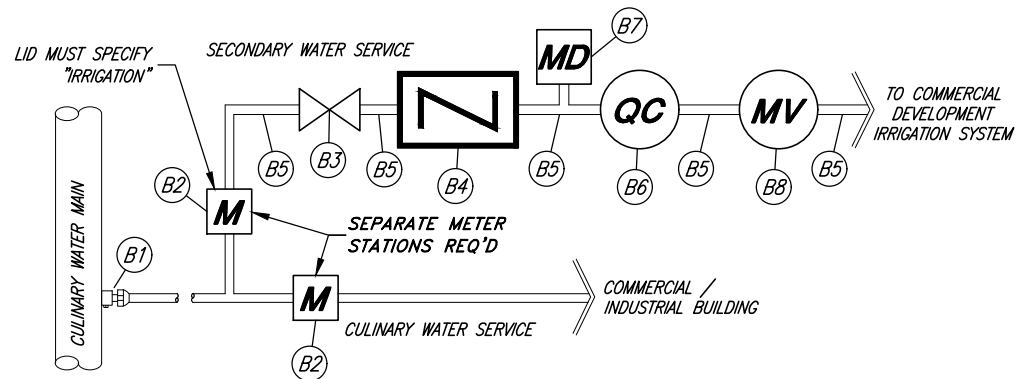

**TYPICAL COMMERCIAL / INDUSTRIAL DEVELOPMENT POINT OF CONNECTION SCHEMATIC DIAGRAM**

REQUIRES PRE-APPROVAL BY THE PUBLIC WORKS DEPARTMENT AND THE CITY ENGINEER PRIOR TO CONSTRUCTION (CONNECTION SHALL BE DETERMINED ON A CASE BY CASE BASIS)

**GENERAL NOTES:**

- DESIGN, CONSTRUCTION, AND INSTALLATION SHALL BE DONE ACCORDING TO AND COMPLY WITH ALL CURRENT ADOPTED BUILDING AND PLUMBING CODES, AND TO MANUFACTURERS WRITTEN INSTRUCTIONS AND RECOMMENDATIONS.
- ALL TESTING, MAINTENANCE, AND/OR REPAIR SHALL BE PERFORMED BY A STATE CERTIFIED BACKFLOW ASSEMBLY TECHNICIAN.
- THE ASSEMBLY MUST BE THOROUGHLY DRAINED AND WINTERIZED EACH WINTER.
- THE RP ASSEMBLY SHALL BE PROTECTED FROM FREEZING AND VANDALISM WHERE APPLICABLE.
- ABOVE GROUND FITTINGS TO BE EPOXY PAINTED BLUE ON THE CULINARY SIDE AND PURPLE ON THE SECONDARY SIDE.
- PROVIDE BOLLARDS OR OTHER PROTECTION IF AND AS DIRECTED BY THE CITY.
- RP ASSEMBLY DESIGN AND CONSTRUCTION DETAILS/DRAWINGS TO BE SUBMITTED TO THE CITY ENGINEER AND THE CITY WATER DIVISION FOR APPROVAL PRIOR TO INSTALLATION.
- LOCATION OF BACKFLOW ASSEMBLY SHALL BE APPROVED BY THE CITY WATER DIVISION PRIOR TO INSTALLATION.
- ALL BACKFLOW PREVENTION ASSEMBLIES SHALL BE TESTED WITHIN 10 DAYS OF INITIAL USE BY A LICENSED BACKFLOW ASSEMBLY TESTER.
- ALL BACKFLOW PREVENTION ASSEMBLIES ARE TO BE TESTED ANNUALLY BY A CERTIFIED TESTER AND REPAIRS OR MAINTENANCE COMPLETED AS NEEDED. ANNUALLY SUBMIT TEST RESULTS TO THE CITY WATER DIVISION.

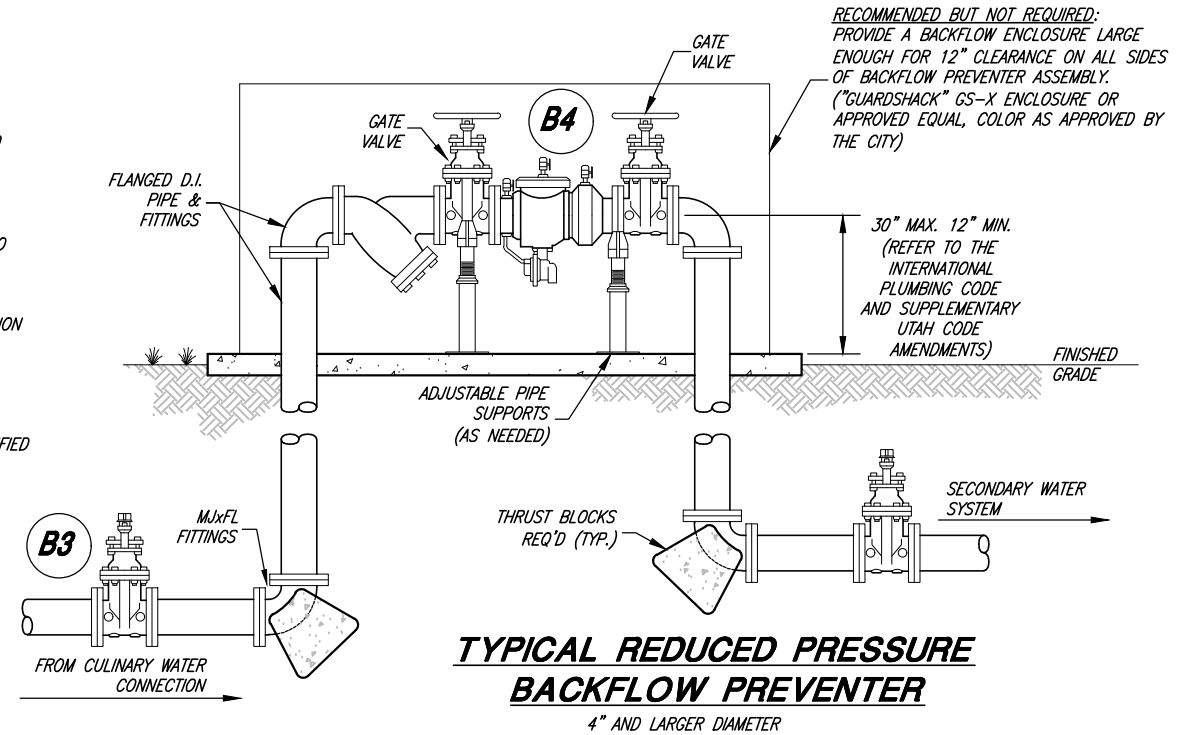

**TYPICAL REDUCED PRESSURE BACKFLOW PREVENTER**  
4" AND LARGER DIAMETER

**REDUCED PRESSURE ASSEMBLY (RP) NOTES:**

- AN RP ASSEMBLY SHALL BE INSTALLED WHEN A SECONDARY SERVICE IS CONNECTED TO THE CULINARY WATER SYSTEM.
- THE RP ASSEMBLY SHALL BE INSTALLED IN A HORIZONTAL POSITION ONLY.
- RP ASSEMBLIES SHALL NOT BE INSTALLED IN A PIT.
- THE BODY OF THE RP ASSEMBLY SHALL BE A MINIMUM OF 12 INCHES FROM ANY WALLS, CEILINGS, OR ENCUMBRANCES AND SHALL BE READILY ACCESSIBLE FOR TESTING, REPAIR AND/OR MAINTENANCE.
- THE BOTTOM OF THE RP ASSEMBLY SHALL BE A MINIMUM OF 12 INCHES ABOVE THE GROUND FLOOR.
- RP VALVE ASSEMBLY AND PIPES TO MATCH SECONDARY LATERAL/MAIN SIZE.
- THE BACKFLOW PREVENTER SHALL BE BRONZE FOR 6-INCH AND SMALLER VALVES, AND EPOXY COATED DUCTILE IRON FOR 8-INCH AND LARGER VALVES.
- BACKFLOW PREVENTION DEVICES SHALL BE SELECTED FROM A LIST OF APPROVED DEVICES SET FORTH BY THE UTAH DIVISION OF DRINKING WATER. REDUCED PRESSURE ASSEMBLIES (RP) AND CITY ENGINEER APPROVED DOUBLE CHECK VALVE ASSEMBLIES (DCA) WILL BE THE ONLY ACCEPTED STYLES OF BACKFLOW PREVENTION DEVICES.

TYPICAL PIPE & FITTING SCHEDULE	
NO.	DESCRIPTION
C1	TO POINT OF CONNECTION - ADAPT AS NECESSARY. ALL WORK SHALL CONFORM TO ALL APPLICABLE CODES
C2	BRASS WYE STRAINER W/ 60 MESH SCREEN
C3	PRESSURE REDUCING VALVE (AS REQUIRED)
C4	DIVISION OF DRINKING WATER APPROVED BACKFLOW PREVENTER UNIT (REDUCED PRESSURE ZONE ASSEMBLY)
C5	BRASS 90 DEGREE ELBOW (TYP.)
C6	BRASS UNION (TYP.)
C7	BRASS PIPE (TYP.)
C9	BRASS COUPLING
C10	PIPE ADAPTER AND MAINLINE PIPE

THE USE OF GALVANIZED STEEL PIPE & FITTINGS IS ACCEPTED WHEN APPROVED BY THE CITY WATER DIVISION

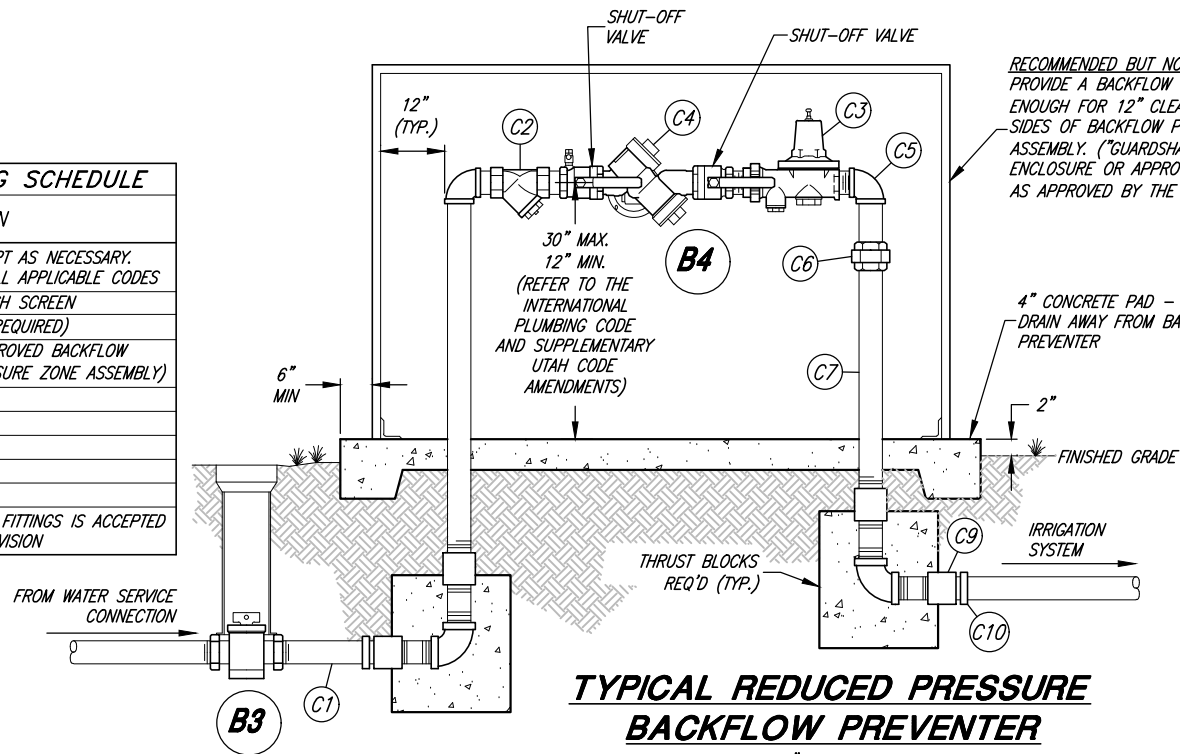

**TYPICAL REDUCED PRESSURE BACKFLOW PREVENTER**  
LESS THAN 3" DIAMETER

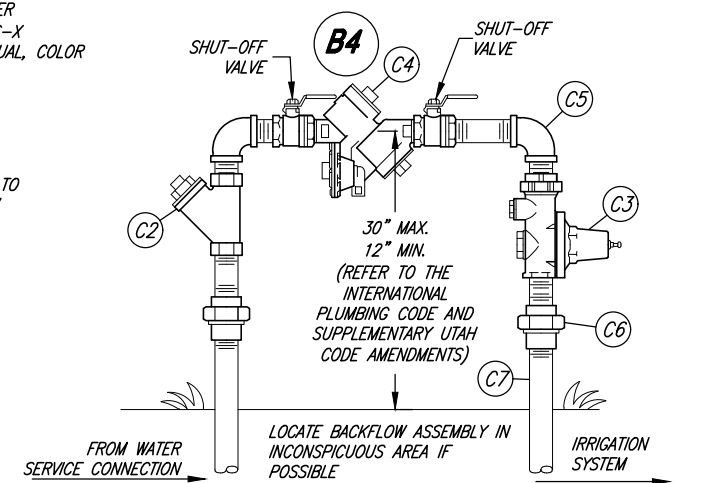

**ALTERNATE REDUCED PRESSURE BACKFLOW PREVENTER**  
OPTIONAL ALTERNATE FOR COMMERCIAL DEVELOPMENTS LESS THAN ONE ACRE



BRANDON K. JONES  
REGISTERED PROFESSIONAL ENGINEER  
No. 5148758  
PROJECT ENGINEER  
11/28/2023  
DATE

REV.	DATE	APPR.

SCALE:  
N. T.S.  
DESIGNED BKJ  
DRAWN BEB  
CHECKED BKJ



**CONSULTING ENGINEERS**  
6080 Fashion Point Drive  
South Ogden, Utah 84403 (801) 476-9767  
www.jonescivil.com

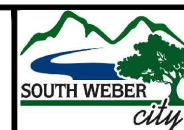

**SOUTH WEBER CITY CORPORATION**  
PUBLIC WORKS - CULINARY WATER SYSTEM STANDARDS  
**REDUCED PRESSURE (RP) BACKFLOW PREVENTION ASSEMBLY**

SHEET:  
**CW7**  
OF 34 SHEETS  
0

**GENERAL NOTES:**

- ALL SANITARY SEWER LATERAL CONNECTIONS ON SEWER MAINS IN NEW SUBDIVISIONS SHALL BE MADE WITH IN LINE PRE-FORMED WYES OR TEES UNLESS OTHERWISE APPROVED BY THE CITY ENGINEER.
- FLOWLINE ELEVATION OF LATERALS SHALL EQUAL THE INSIDE TOP OF PIPE ON MAINLINE AT THE CONNECTING POINT (THE LATERAL TAP SHALL BE IN THE TOP QUARTER OF THE SEWER MAIN LINE PREFERABLY IN THE 10:00 OR 2:00 POSITION).
- SANITARY SEWER SERVICE LATERAL CONNECTIONS SHALL NOT BE ALLOWED IN SEWER MANHOLES.
- SANITARY SEWER MAINS AND LATERALS SHALL BE "GREEN" IN COLOR. LAND DRAIN MAIN LINES SHALL BE "GREEN" IN COLOR AND LAND DRAIN LATERAL LINES SHALL BE "WHITE" IN COLOR. IRRIGATION PIPES SHALL BE "PURPLE" IN COLOR. PREVIOUS YEARS PIPE COLORS VARY THROUGHOUT THE CITY. CONTRACTOR TO VERIFY EXISTING PIPE PRIOR TO MAKING ANY CONNECTION.
- INSERTA TEE PRODUCT IS NOT APPROVED BY THE CITY
- ALL CLEANOUTS SHALL BE MARKED AND FITTED WITH A METAL LID FOR LOCATION PURPOSES
- ALL CULINARY WATER MAINS AND SERVICES MUST MAINTAIN A MINIMUM SEPARATION ABOVE ALL SEWER MAINS AND LATERALS OF 18" VERTICAL AND 10'-0" HORIZONTAL IN ACCORDANCE WITH THE STATE OF UTAH DIVISION OF DRINKING WATER (DDW) RULES SECTION R309-550-7. EXCEPTIONS MUST BE APPROVED BY DDW.
- ALL SANITARY SEWER LINES SHALL BE INSPECTED BY MEANS OF VIDEO CAMERA WHEN CONSTRUCTED.
- STAMPED STAINLESS STEEL PINS USED FOR LATERAL LOCATING ARE REQUIRED BY THE CITY. BLANK S.S. PINS SHALL BE PROVIDED BY THE CITY AND INSTALLED AND STAMPED BY THE CONTRACTOR DURING ALL NEW CONSTRUCTION OR RESTORED WHEN REPLACING DAMAGED CURB & GUTTER DUE TO ANY CONSTRUCTION RELATED ACTIVITY. S.S. PINS SHALL BE STAMPED "S" FOR SANITARY SEWER, "W" FOR CULINARY WATER, AND "L" FOR LAND DRAIN.
- DOWNSTEAM LAND DRAIN CONNECTION TO AN EXISTING STORM DRAIN SYSTEM IS REQUIRED.

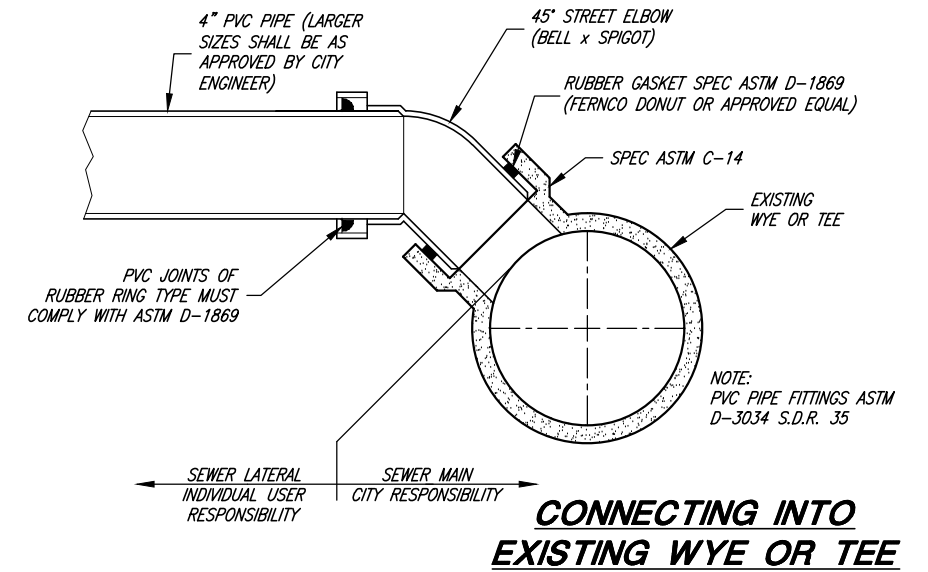

**CONNECTING INTO EXISTING WYE OR TEE**

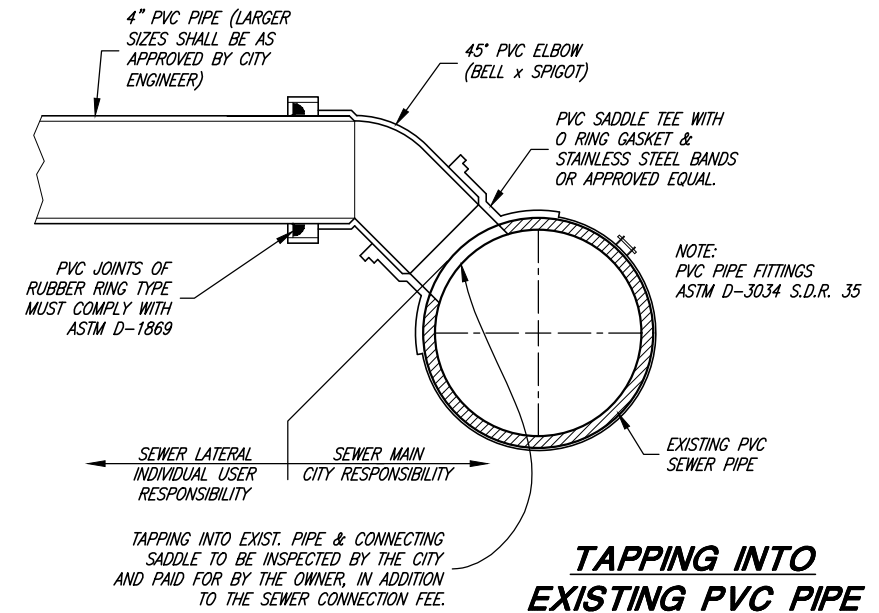

**TAPPING INTO EXISTING PVC PIPE**

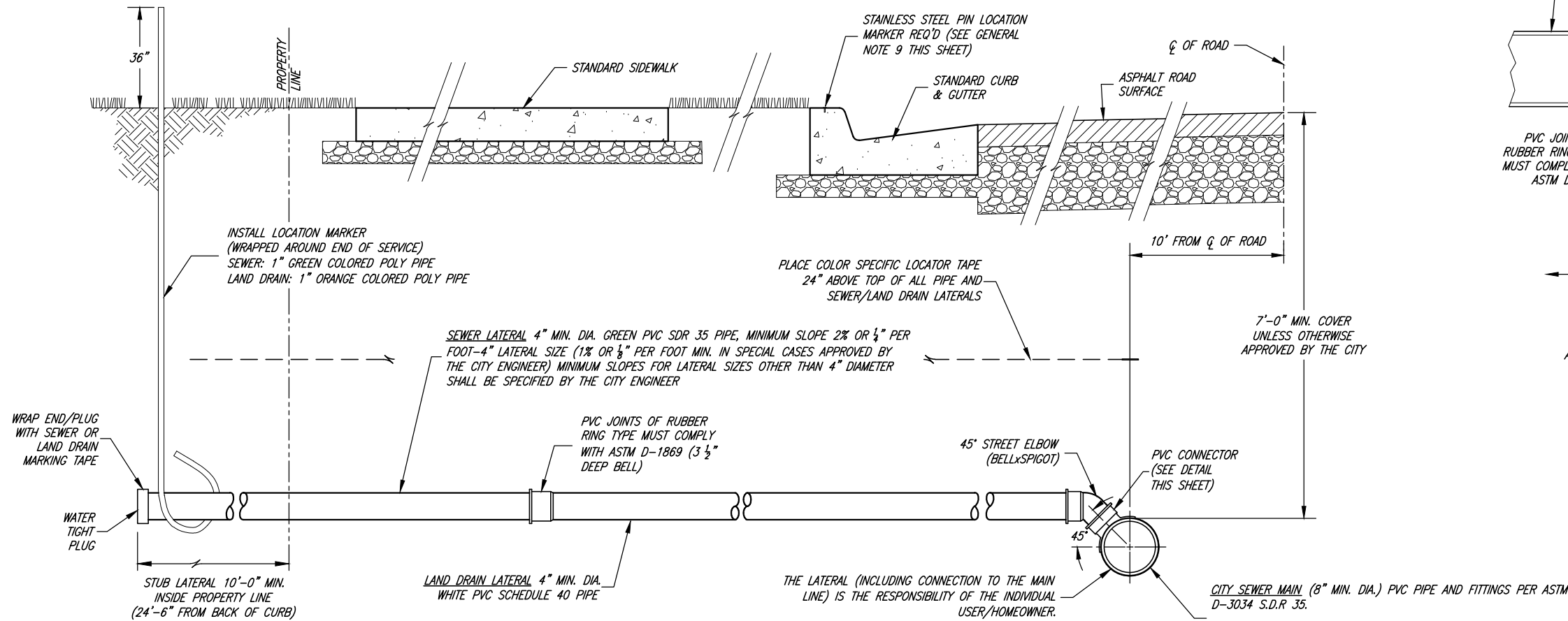

**TYPICAL SEWER / LAND DRAIN LATERALS CONNECTION**



BRANDON KENT JONES  
No. 5148758  
PROJECT ENGINEER  
11/28/2023  
DATE

REV.	DATE	APPR.

SCALE:  
N. T.S.  
DESIGNED BKJ  
DRAWN BEB  
CHECKED BKJ



**CONSULTING ENGINEERS**  
6080 Fashion Point Drive  
South Ogden, Utah 84403 (801) 476-9767  
www.jonescivil.com

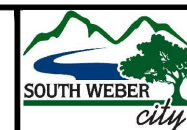

**SOUTH WEBER CITY CORPORATION**  
**PUBLIC WORKS - SANITARY SEWER SYSTEM STANDARDS**  
**SEWER / LAND DRAIN LATERAL & MAIN LINE CONNECTION DETAILS**

SHEET:  
**SS1**  
OF 34 SHEETS  
0

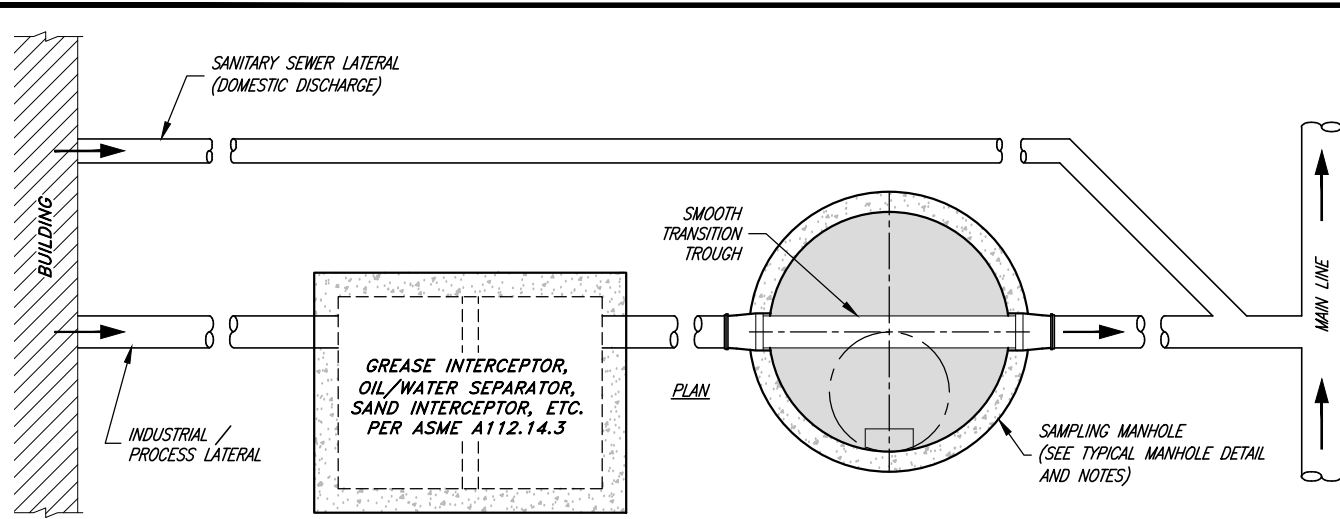

**SAMPLING MANHOLE**

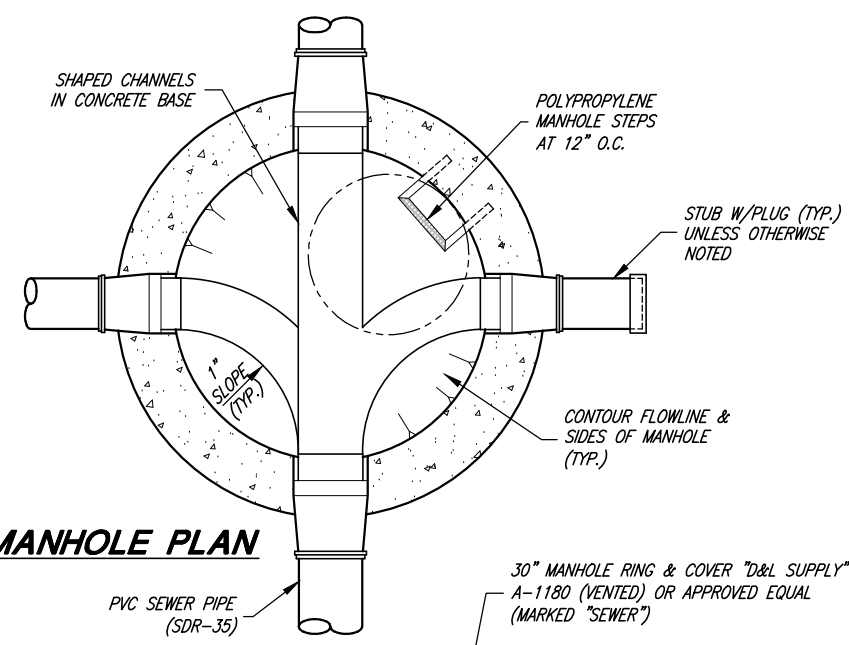

**MANHOLE PLAN**

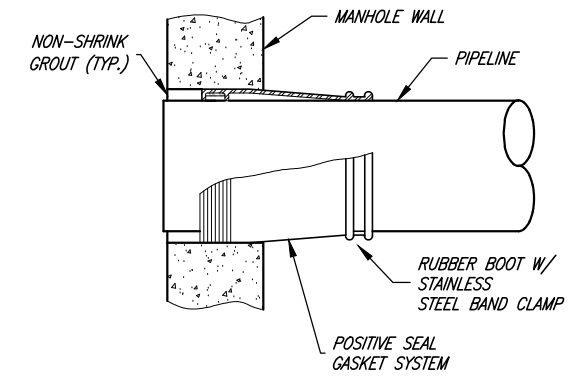

**RUBBER BOOT DETAIL**

- DROP MANHOLE NOTES:**
- A. USE DROP MANHOLE ONLY WHEN DROP EXCEEDS 2'-0" (UAC R317-3)
  - B. DROP MANHOLE SHALL CONSIST OF ASTM D3034 SDR 35 PVC PIPE WITH SDR 35 PVC GASKETED FITTINGS.
  - C. DUE TO THE UNEQUAL EARTH PRESSURES THAT WOULD RESULT FROM THE BACKFILLING OPERATION IN THE VICINITY OF THE MANHOLE, THE ENTIRE OUTSIDE DROP CONNECTIONS SHALL BE ENCASED IN CONCRETE. (UAC R317-3)
  - D. DROP MANHOLES SHOULD BE USED ON STREETS WITH GRADES 8% OR GREATER OR AS OTHERWISE DIRECTED BY THE CITY ENGINEER.

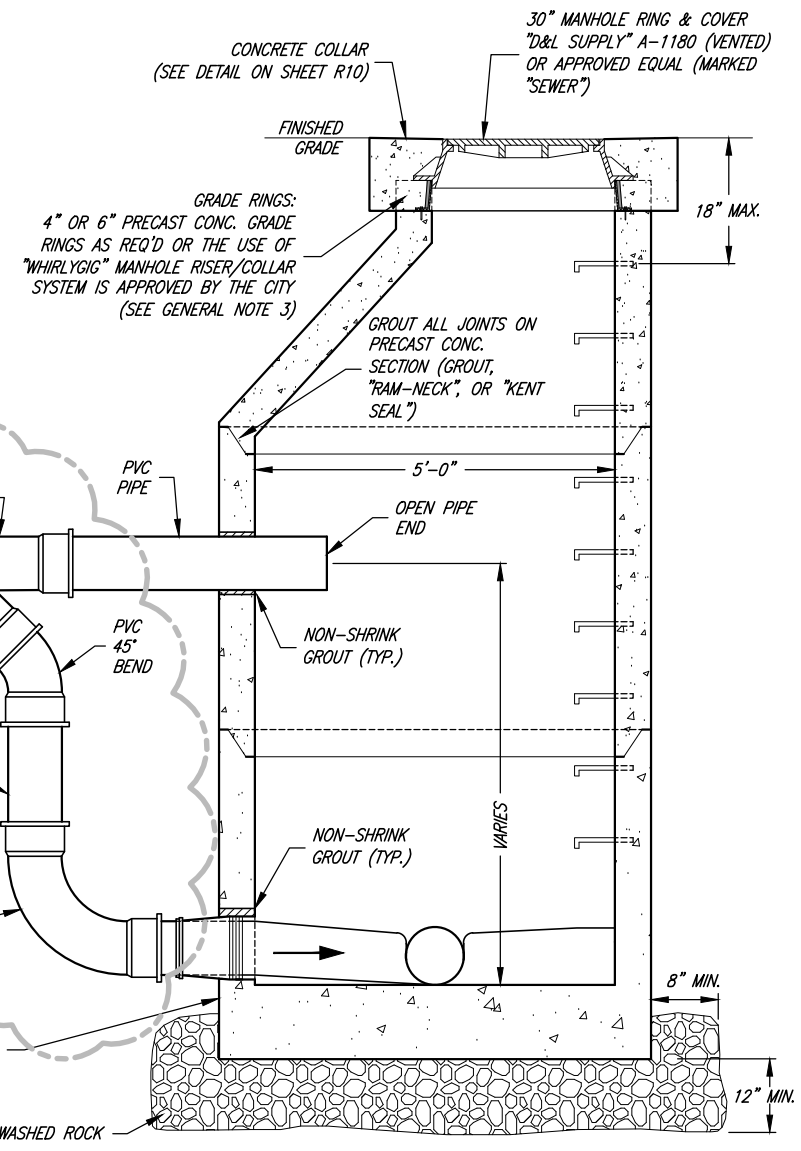

**TYPICAL DROP MANHOLE SECTION**

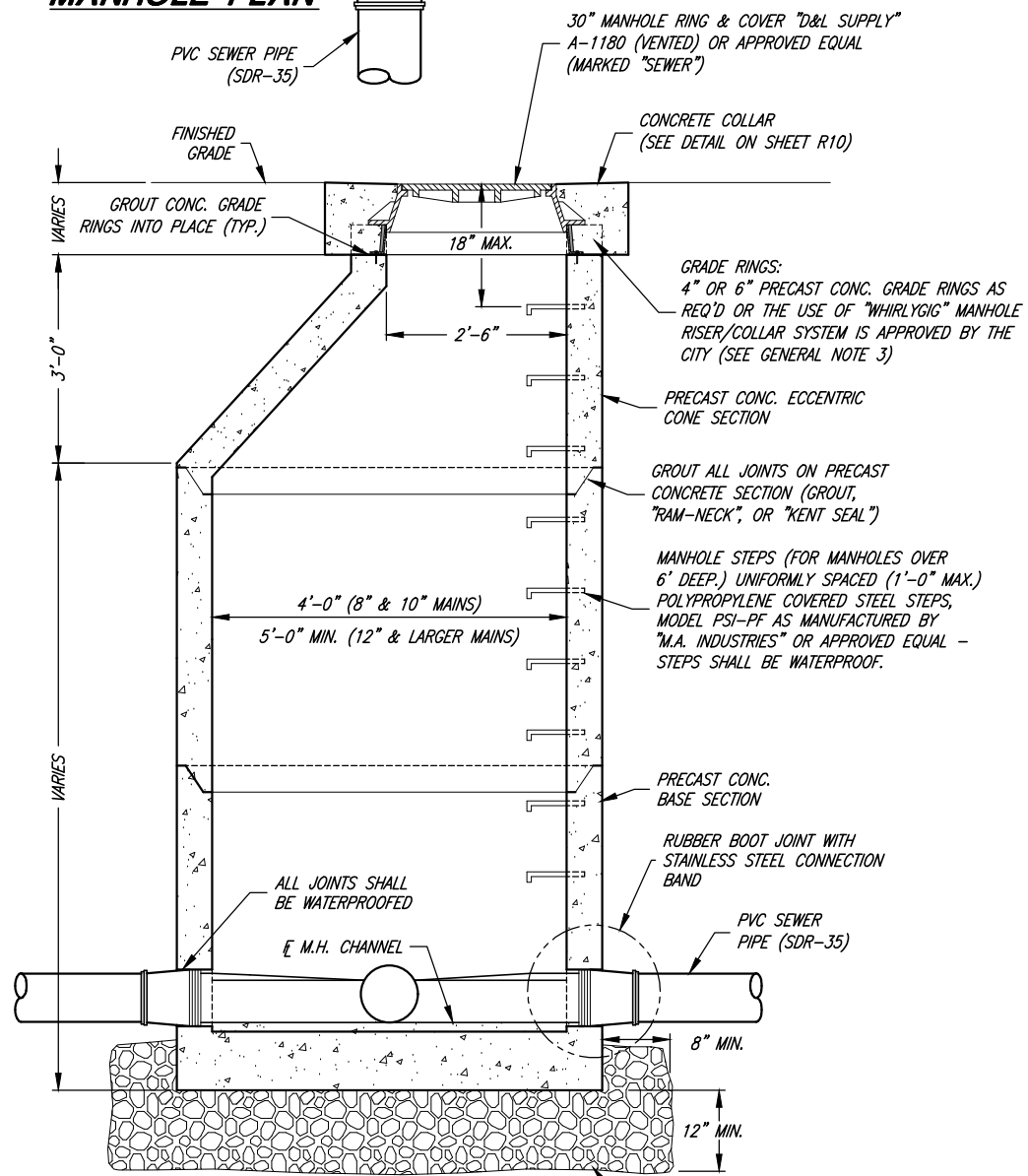

**TYPICAL MANHOLE SECTION**

- GENERAL NOTES:**
1. SECURE INVERTS IN ALL MANHOLES DURING CONSTRUCTION SO AS TO PREVENT GRAVEL AND OTHER DEBRIS FROM COLLECTING INSIDE.
  2. A LARGER DIAMETER MANHOLE MAY BE REQUIRED BY THE CITY ENGINEER AFTER EVALUATION OF THE NUMBER, SIZE, AND ANGLE OF THE PIPES THAT CONNECT TO THE MANHOLE.
  3. NO MORE THAN 12" OF GRADE RINGS TO BE ALLOWED ON ANY MANHOLE.
  4. ALL TERMINATING SEWER MAINS SHALL END WITH A CITY STANDARD MANHOLE.
  5. SERVICE LATERAL CONNECTIONS SHALL NOT BE ALLOWED IN SEWER MANHOLES.
  6. ALL SANITARY SEWER LINES SHALL BE INSPECTED BY MEANS OF VIDEO CAMERA AND AIR TESTED WHEN CONSTRUCTED. SEE APWA 33 08 00 AND CITY MODIFICATIONS FOR MORE INFORMATION.
  7. WHERE THE DIFFERENCE IN ELEVATION BETWEEN THE INCOMING SEWER AND MANHOLE INVERT IS LESS THAN 24 INCHES, THE INVERT SHOULD BE FILLETED.
  8. FLAT MANHOLE RINGS & COVERS (SLAB CONSTRUCTION) ARE NOT ALLOWED ON ANY MANHOLE CONE SECTION.
  9. ALL SEWER MANHOLE COVERS TO BE VENTED UNLESS OTHERWISE NOTED.



BRANDON KENT JONES  
No. 5148758  
PROJECT ENGINEER  
11/28/2023  
DATE

REV.	DATE	APPR.

SCALE:  
N. T.S.  
DESIGNED BKJ  
DRAWN BEB  
CHECKED BKJ



**CONSULTING ENGINEERS**  
6080 Fashion Point Drive  
South Ogden, Utah 84403 (801) 476-9767  
www.jonescivil.com

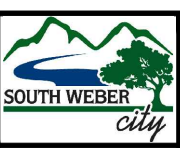

**SOUTH WEBER CITY CORPORATION**  
**PUBLIC WORKS - SANITARY SEWER SYSTEM STANDARDS**  
**SANITARY SEWER MANHOLE DETAILS**

SHEET:  
**SS2**  
OF 34 SHEETS  
0



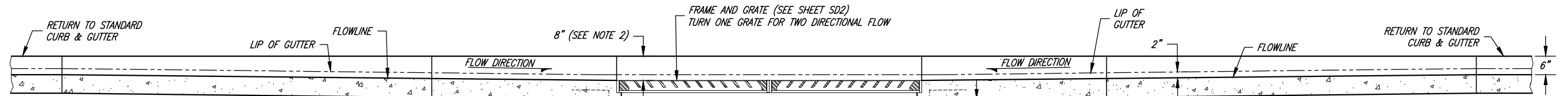
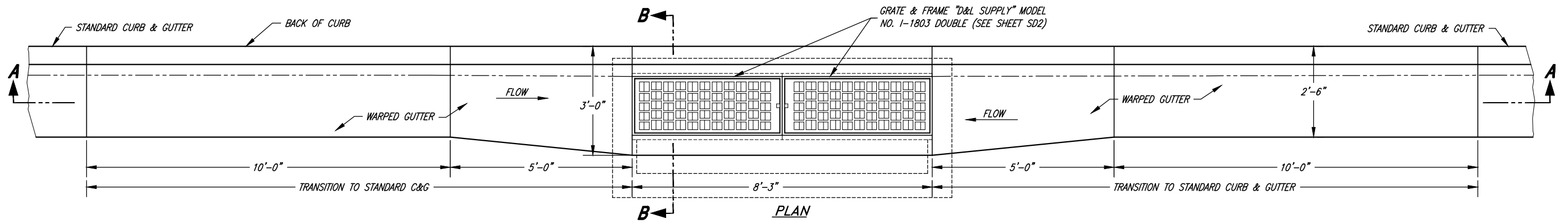

**STANDARD CATCH BASIN DIMENSION TABLE**

PIPE SIZE (IN.)	"X"	SINGLE CATCH BASIN		DOUBLE "Y"	"Z" MIN.
		"Y" (ANGLE A)	"Y" (ANGLE B)		
15	2'-6"	4'-0"	4'-0"	8'-0"	2'-0"
18	2'-6"	4'-0"	4'-0"	8'-0"	2'-6"
21	4'-0"	4'-0"	4'-0"	8'-0"	3'-0"
24	4'-0"	4'-0"	5'-0"	8'-0"	3'-0"
30	4'-0"	4'-0"	6'-0"	8'-0"	3'-6"
36	4'-0"	5'-0"	6'-0"	8'-0"	4'-0"
42	6'-0"	6'-0"	7'-0"	8'-0"	5'-0"
48	6'-0"	6'-0"	8'-0"	8'-0"	5'-6"

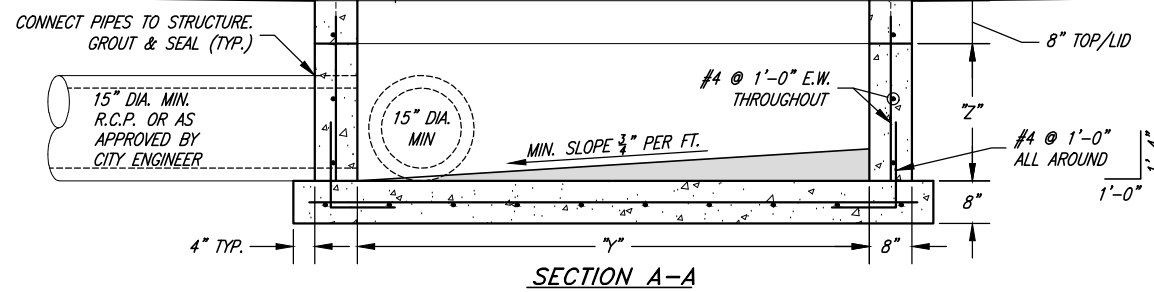

**DOUBLE CATCH BASIN**

**GENERAL NOTES:**

1. ALL CATCH BASIN BOX SIZES REFLECT DIMENSIONS FOR THE MINIMUM 15" PIPE SIZE. BOX DIMENSIONS MUST INCREASE PROPORTIONALLY TO ACCOMMODATE LARGER PIPE SIZES.
2. DEPTH MAY VARY FROM 6" TO 10" AS DIRECTED BY THE CITY ENGINEER
3. CAST-IN-PLACE CONCRETE CATCH BASINS CAN BE REPLACED WITH PRECAST CONCRETE CATCH BASINS WITH HL-93 DECK LOADING AND COMPARABLE SIZE.
4. ALL BOXES SHALL BE FORMED ON THE INSIDE AND OUTSIDE OF THE BOX AND INSPECTED BY THE CITY PRIOR TO THE PLACING OF CONCRETE.
5. DOUBLE CATCH BASINS WILL BE REQUIRED IN LOCATIONS SPECIFIED BY THE CITY ENGINEER (TYPICALLY IN LOW SPOTS OR WHERE ADDITIONAL INLET CAPACITY IS NEEDED).
6. STORM DRAIN LINES SHALL BE 15 INCH MINIMUM DIAMETER REINFORCED CONCRETE PIPE (RCP), OF APPROPRIATE CLASS.
7. ALTERNATE STRUCTURE (E.G. COMBO BOXES) MAY BE USED WITH APPROVAL OF THE CITY ENGINEER. STRUCTURES SHALL FOLLOW APWA STANDARD PLANS AND BE A COMMON SIZE.

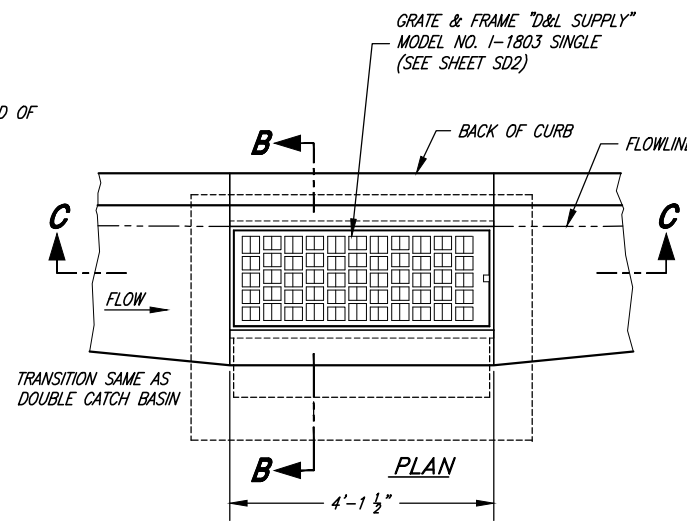
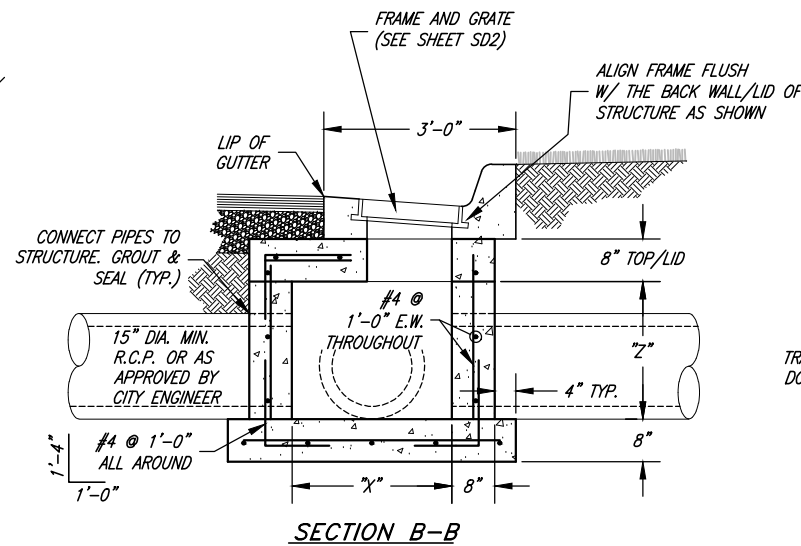
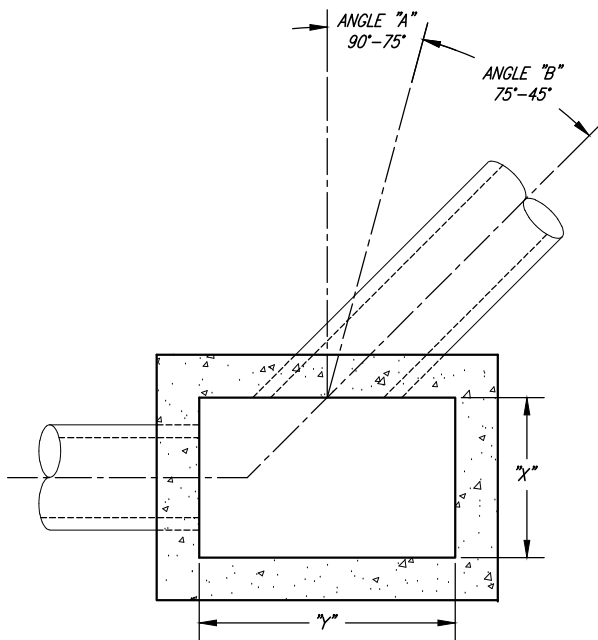

**SINGLE CATCH BASIN**

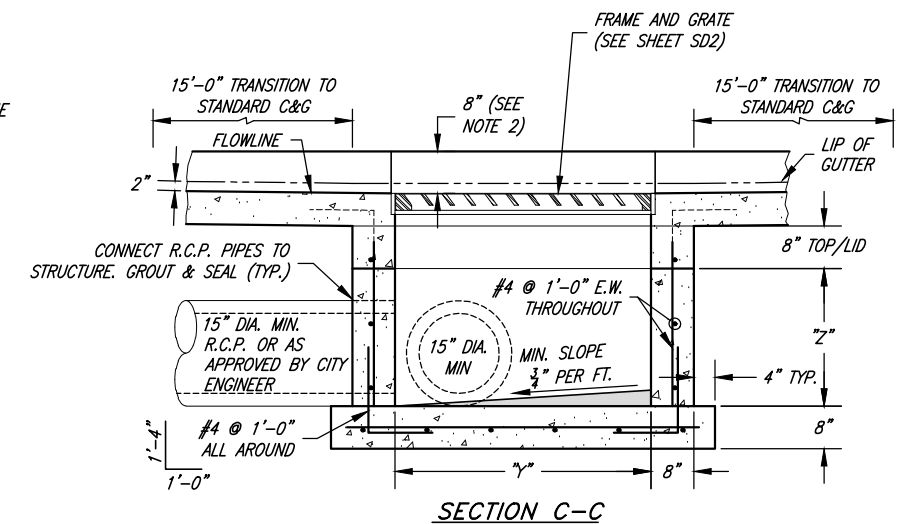

BRANDON KENT JONES  
No. 5148758  
PROJECT ENGINEER  
11/28/2023  
DATE

REV.	DATE	APPR.

SCALE:  
N. T.S.  
DESIGNED *BKJ*  
DRAWN *BEB*  
CHECKED *BKJ*



**CONSULTING ENGINEERS**  
6080 Fashion Point Drive  
South Ogden, Utah 84403 (801) 476-9767  
www.jonescivil.com

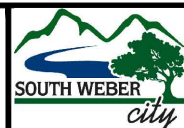

**SOUTH WEBER CITY CORPORATION**  
**PUBLIC WORKS - STORM DRAIN SYSTEM STANDARDS**  
**SINGLE AND DOUBLE CATCH BASIN DETAILS**

SHEET:  
**SD1**  
OF 34 SHEETS  
0



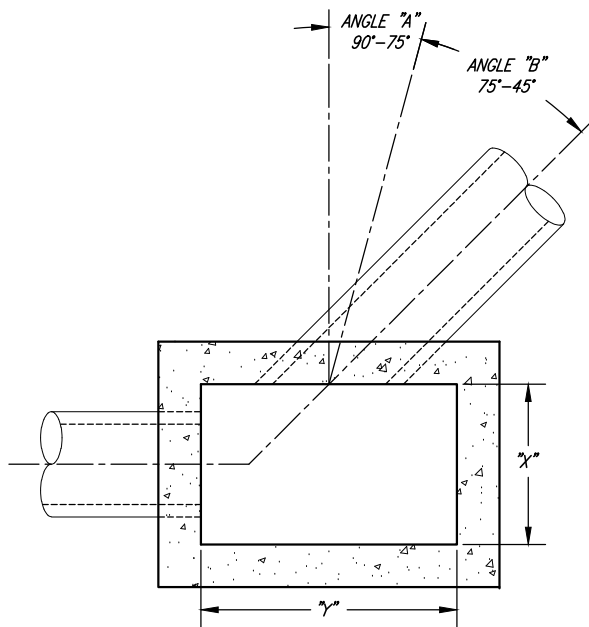

PIPE SIZE (IN.)	INLET BOX			"Z" MIN.
	"X"	"Y" (ANGLE A)	"Y" (ANGLE B)	
15	2'-6"	4'-0"	4'-0"	2'-0"
18	2'-6"	4'-0"	4'-0"	2'-6"
21	4'-0"	4'-0"	4'-0"	3'-0"
24	4'-0"	4'-0"	5'-0"	3'-0"
30	4'-0"	4'-0"	6'-0"	3'-6"
36	4'-0"	4'-0"	6'-0"	4'-0"
42	6'-0"	6'-0"	7'-0"	5'-0"
48	6'-0"	6'-0"	8'-0"	5'-6"

**GENERAL NOTE:**  
STORM DRAIN LINES SHALL BE 15 INCH MINIMUM DIAMETER REINFORCED CONCRETE PIPE (RCP), OF APPROPRIATE CLASS.

- DRAINAGE BOX NOTES:**
- ALL BOX SIZES REFLECT DIMENSIONS FOR THE MINIMUM 15" RCP PIPE SIZE. BOX DIMENSIONS MUST INCREASE PROPORTIONALLY TO ACCOMMODATE LARGER PIPE SIZES. (SEE TABLE THIS SHEET)
  - CAST-IN-PLACE CONCRETE STRUCTURES CAN BE REPLACED WITH PRECAST CONCRETE STRUCTURES WITH HL-93 DECK LOADING AND COMPARABLE SIZE.
  - ALL BOXES SHALL BE FORMED ON THE INSIDE AND OUTSIDE OF THE BOX AND INSPECTED BY THE CITY PRIOR TO THE PLACING OF CONCRETE.

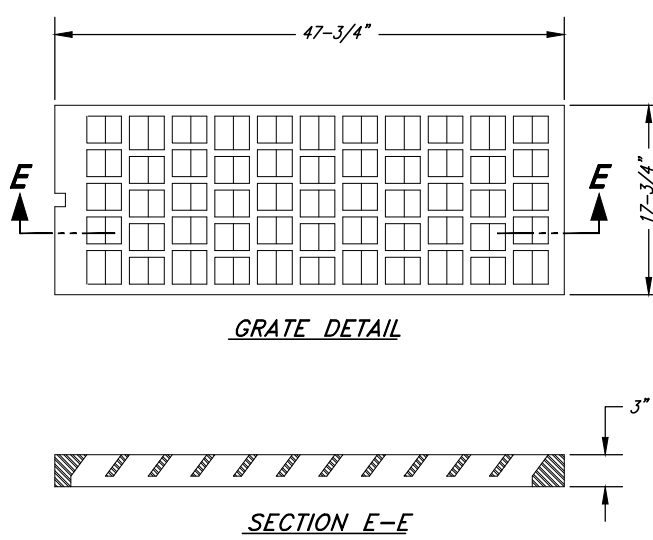
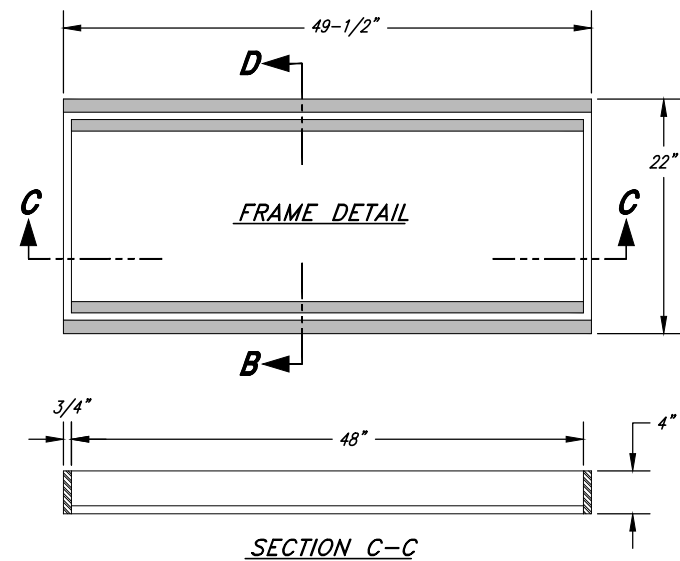
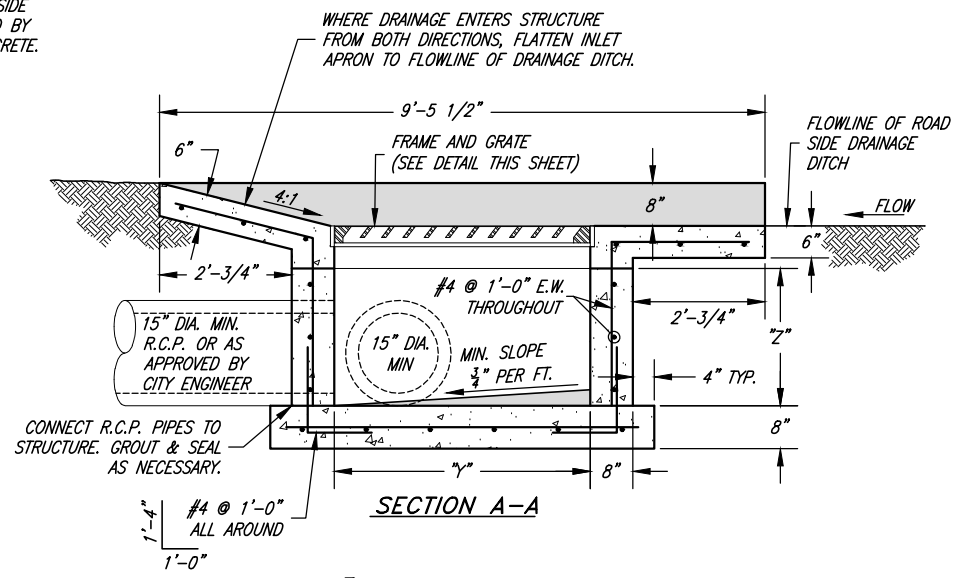
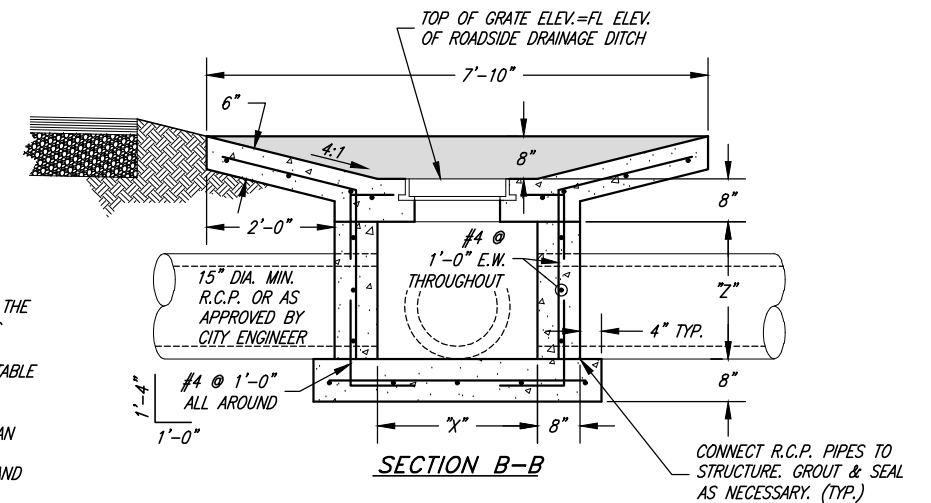

**FRAME & GRATE DETAILS**

- FRAME AND GRATE NOTES:**
- GRATE AND FRAME SHALL BE AS MANUFACTURED BY "D&L SUPPLY" 1-1803
  - BICYCLE SAFE GRATE REQUIRED.
  - "OR EQUAL" GRATES AND FRAMES WILL BE CONSIDERED AS APPROVED BY THE CITY ENGINEER.

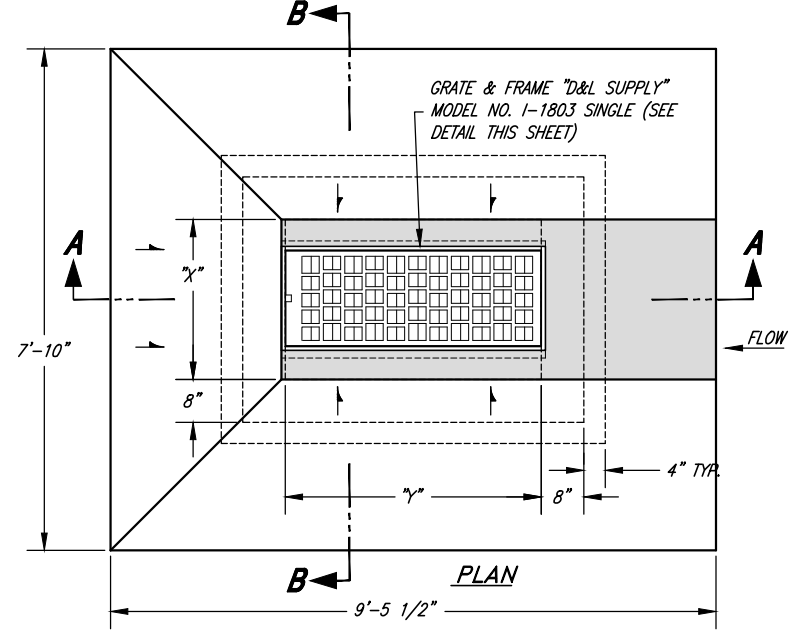
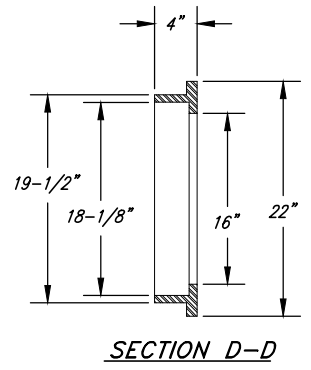

**DRAINAGE DITCH / SWALE INLET BOX**



BRANDON KENT JONES  
No. 5148758  
PROJECT ENGINEER  
11/28/2023  
DATE

REV.	DATE	APPR.

SCALE:  
N. T.S.  
DESIGNED: BKJ  
DRAWN: BEB  
CHECKED: BKJ



**CONSULTING ENGINEERS**  
6080 Fashion Point Drive  
South Ogden, Utah 84403 (801) 476-9767  
www.jonescivil.com

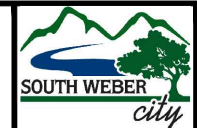

**SOUTH WEBER CITY CORPORATION**  
PUBLIC WORKS - STORM DRAIN SYSTEM STANDARDS  
**DRAINAGE INLET BOX AND GENERAL GRATE & FRAME DETAILS**

SHEET:  
**SD2**  
OF 34 SHEETS  
0

PIPE SIZES		JUNCTION MANHOLE (ANGLE / ARC DISTANCE)										
M.H. SIZE	IN-LINE M.H.	180°	90°	85°	80°	75°	70°	65°	60°	55°	50°	45°
4" M.H.	15"-24"	15"-18"	15"-18"	15"-18"	15"	15"	15"	15"	15"	15"	15"	15"
5" M.H.	27"-30"	21"-24"	21"-24"	18"-21"	18"-21"	15"-18"	15"-18"	15"	15"	15"	15"	15"
6" M.H.	36"-48"	27"-30"	27"-30"	24"-27"	24"	21"-24"	21"	18"	15"-18"	15"	15"	15"
7" M.H.	54"	36"	36"	30"	27"-30"	27"	24"	21"-24"	21"	18"	15"	15"
8" M.H.	60"	42"	42"	36"	36"	30"	27"-30"	27"	24"	21"	18"	15"

- MANHOLE SIZING NOTES:**
- SUGGESTED "A" DISTANCE IS 6" OR GREATER FOR 48", 60" AND 72" DIAMETER MANHOLES
  - SUGGESTED "A" DISTANCE IS 8" OR GREATER FOR 84" AND 96" DIAMETER MANHOLES

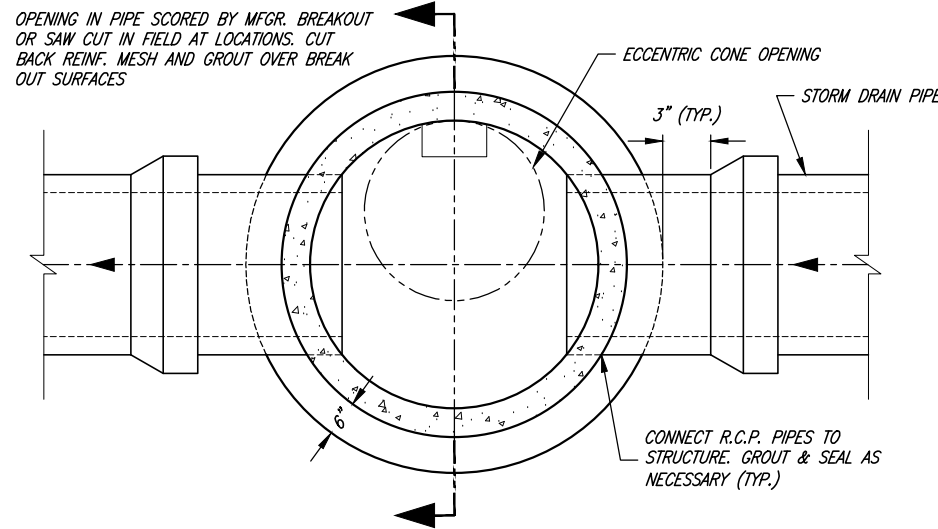
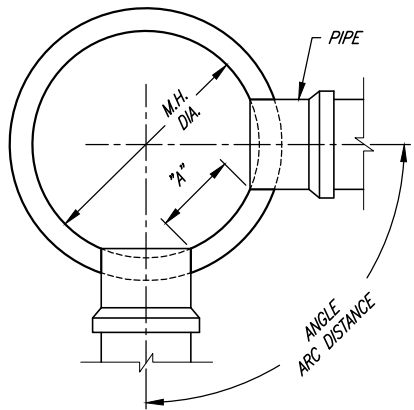

**TYPICAL LINE MANHOLE**

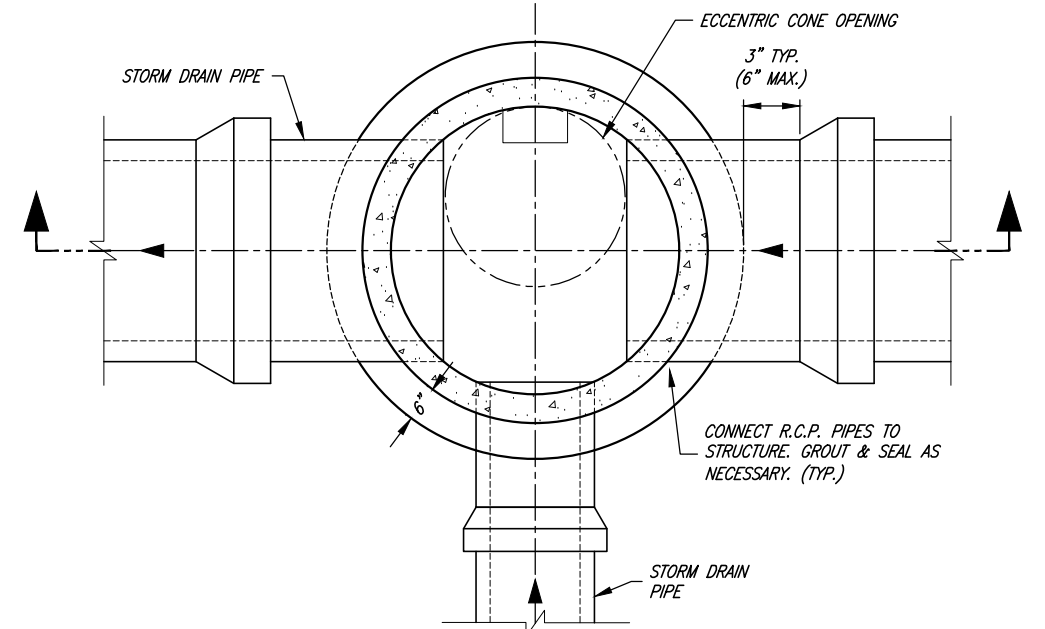

**TYPICAL JUNCTION MANHOLE**

**GENERAL NOTES:**

- A LARGER DIAMETER MANHOLE MAY BE REQUIRED BY THE CITY ENGINEER AFTER EVALUATION OF THE NUMBER, SIZE, AND ANGLE OF THE PIPES THAT CONNECT TO THE MANHOLE.
- NO MORE THAN 12" OF GRADE RINGS TO BE ALLOWED ON ANY MANHOLE
- PLYWOOD COVERS SHALL BE USED AT MANHOLE FLOOR TO COVER FLOWLINE DURING CONSTRUCTION AND MAINTENANCE ACTIVITIES.
- ALL INTERIOR JOINTS SHALL BE SMOOTH AND EVENLY GROUTED WITH NON-SHRINK GROUT MIX.
- MANHOLE STEPS UNIFORMLY SPACED (1'-0" MAX) ON ALL MANHOLES. POLYPROPYLENE COVERED STEEL STEPS, MODEL PSI-PF AS MANUFACTURED BY "M.A. INDUSTRIES" OR APPROVED EQUAL - INSTALLATION OF STEPS SHALL BE WATERPROOF.
- STORM DRAIN LINES SHALL BE 15 INCH MINIMUM DIAMETER REINFORCED CONCRETE PIPE (RCP), OF APPROPRIATE CLASS.
- FLAT MANHOLE RINGS & COVERS (SLAB CONSTRUCTION) ARE NOT ALLOWED ON ANY MANHOLE CONE SECTION.
- THE USE OF STORM DRAIN UTILITY VAULTS (BOXES) WITH STD. 30" C.I. RING & COVER ("D&L SUPPLY" A-1181 MARKED "STORM DRAIN") AND A CONCRETE COLLAR IS ACCEPTED WHEN APPROVED BY THE CITY ENGINEER.
- CONTOUR THE FLOWLINE & SIDES OF ANY LINE OR JUNCTION MANHOLES WHEN DIRECTED BY THE CITY ENGINEER.

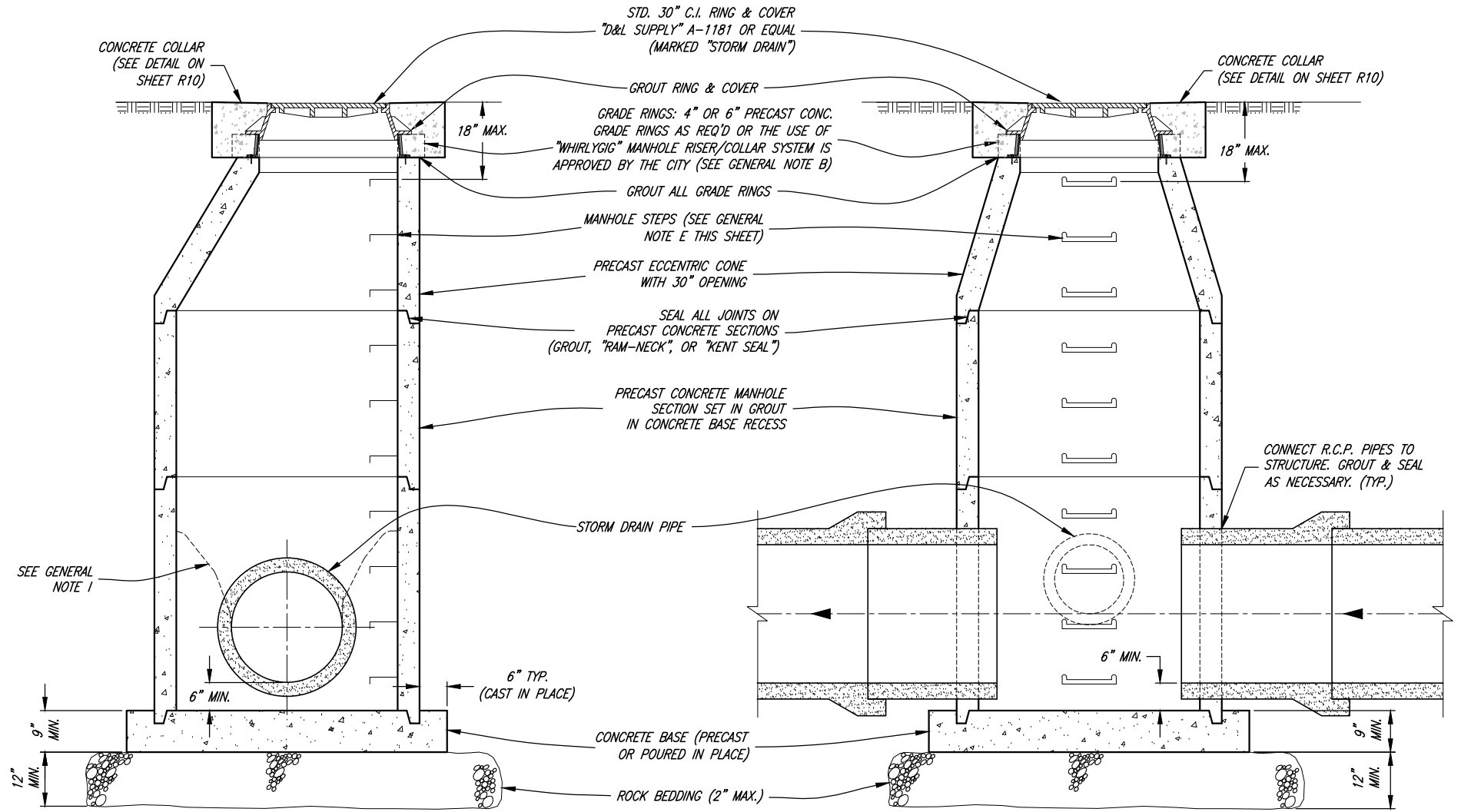

BRANDON K. JONES  
PROJECT ENGINEER  
11/28/2023  
DATE

REV.	DATE	APPR.

SCALE: N. T.S.  
DESIGNED: BKJ  
DRAWN: BEB  
CHECKED: BKJ



**CONSULTING ENGINEERS**  
6080 Fashion Point Drive  
South Ogden, Utah 84403 (801) 476-9767  
www.jonescivil.com

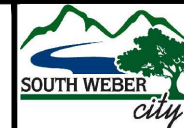

**SOUTH WEBER CITY CORPORATION**  
PUBLIC WORKS - STORM DRAIN SYSTEM STANDARDS  
**STORM DRAIN MANHOLE DETAILS**

SHEET: **SD3**  
OF 34 SHEETS  
0

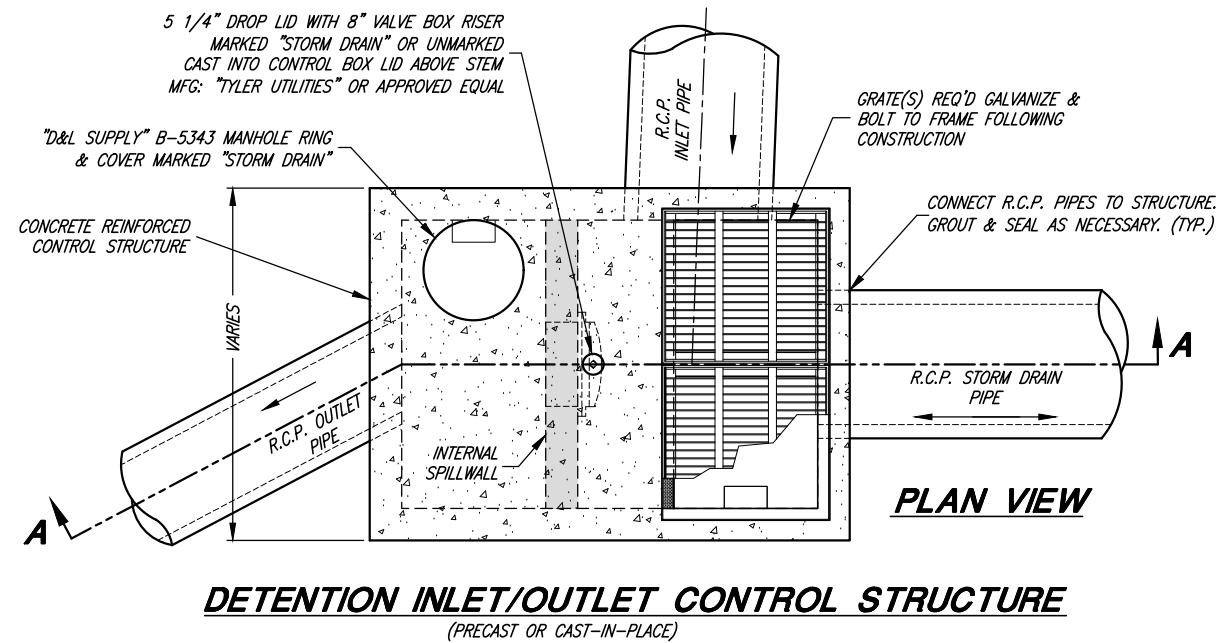

**DETENTION INLET/OUTLET CONTROL STRUCTURE**  
(PRECAST OR CAST-IN-PLACE)

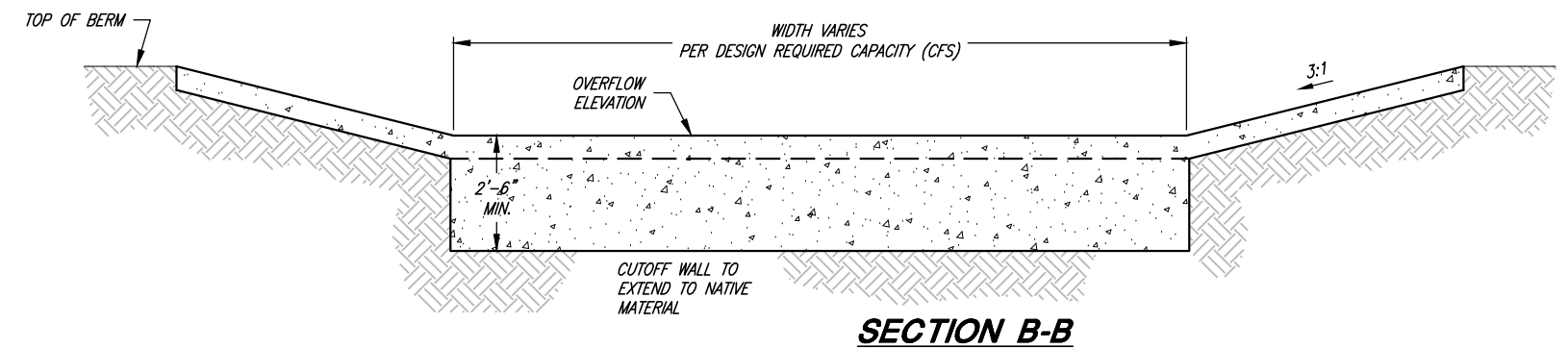

**SECTION B-B**

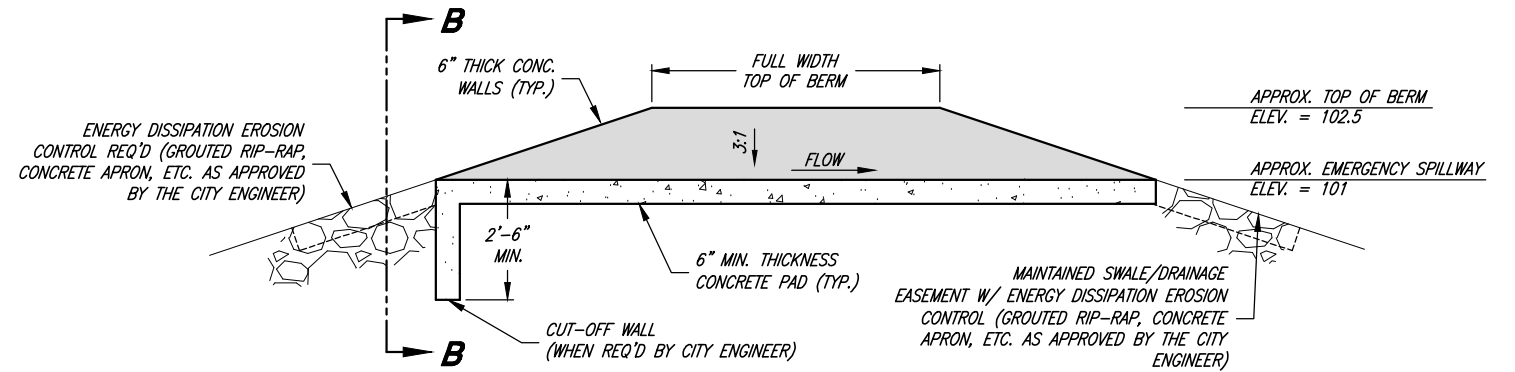

**EMERGENCY OVERFLOW**

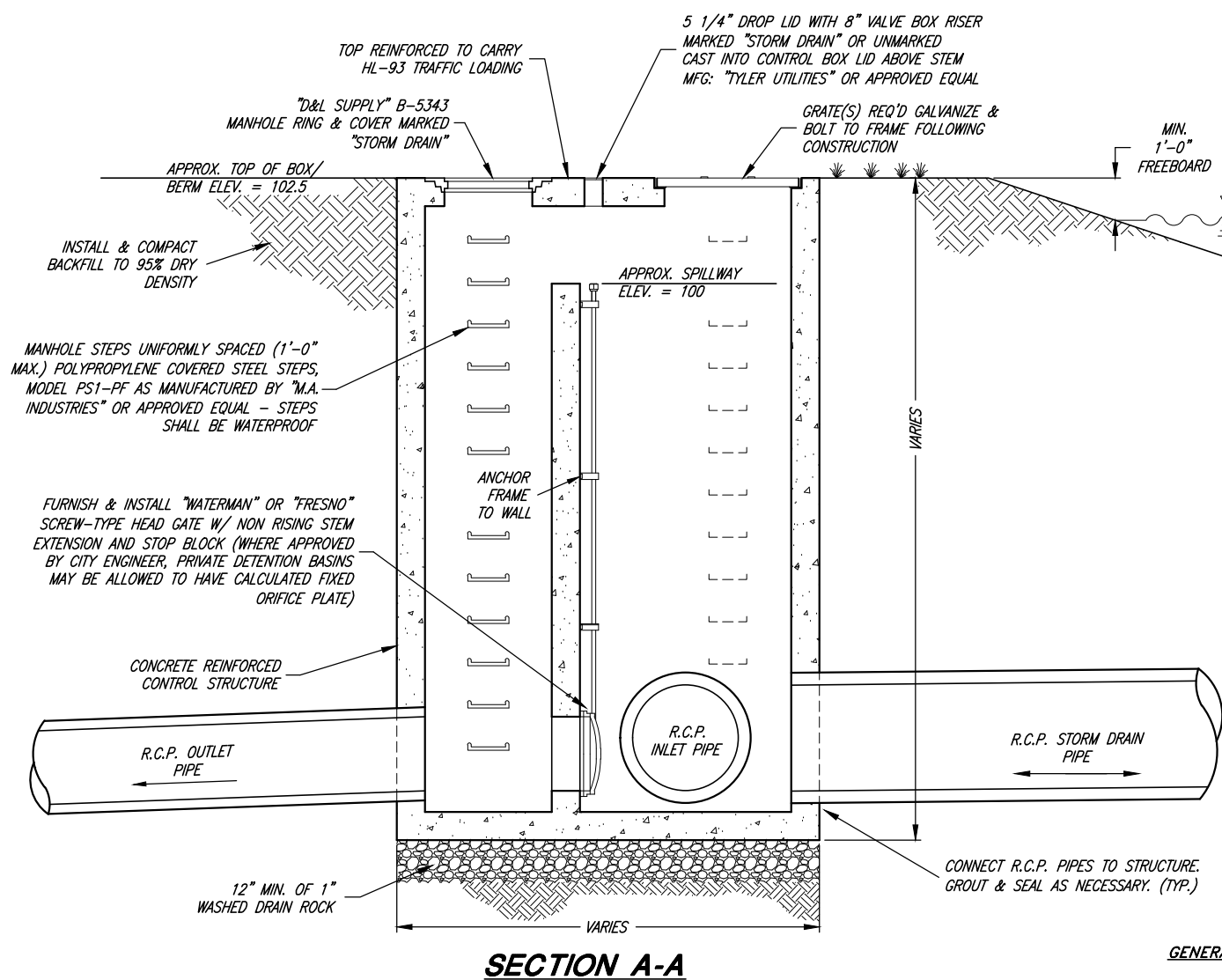

**SECTION A-A**

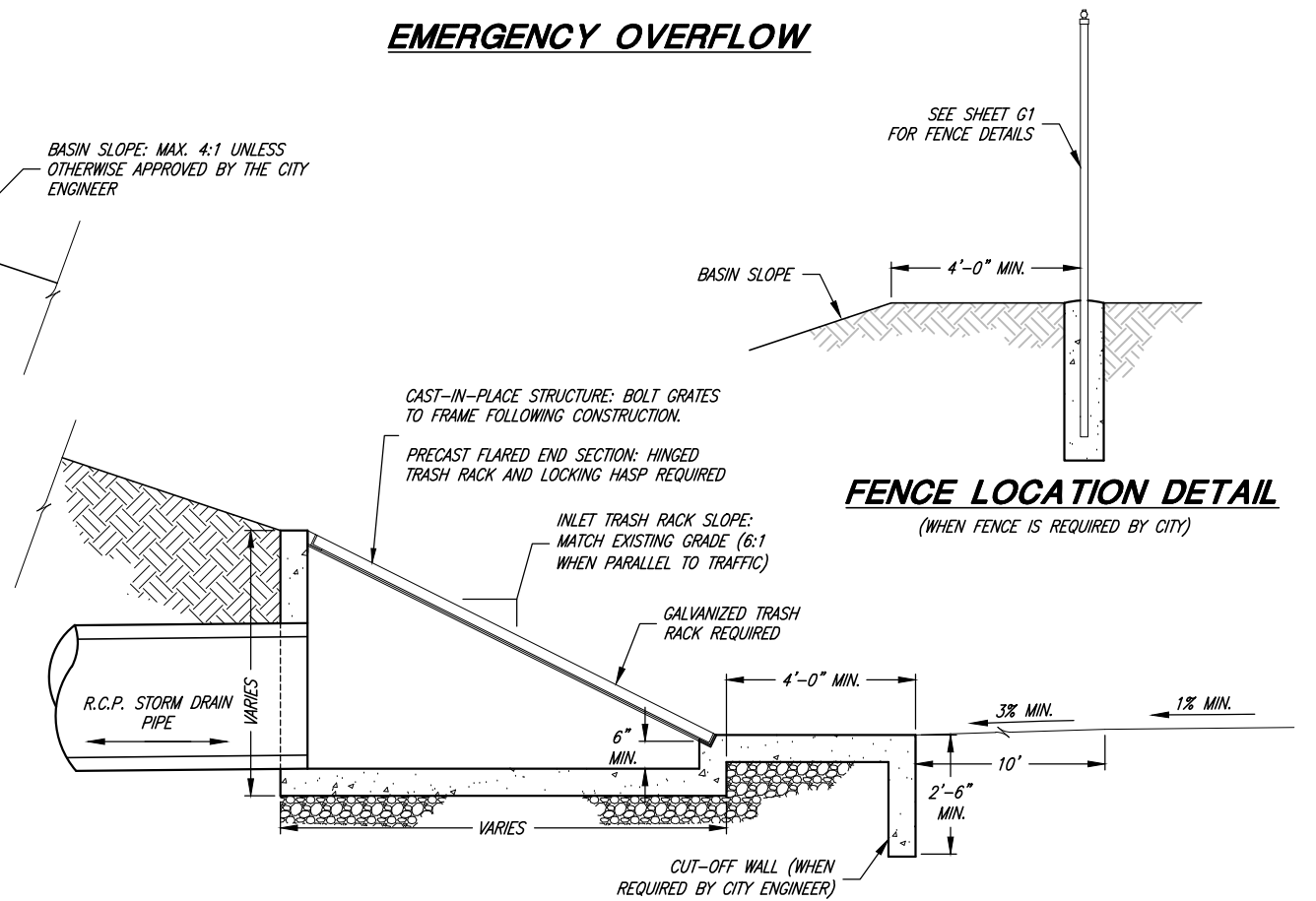

**INCLINED GRATE STORM DRAIN INLET**

\*\*INCLINED GRATES ARE REQ'D ON ALL PIPES/INLETS WHERE OPEN CHANNELS, DITCHES, OR PONDS DISCHARGE DIRECTLY INTO THE STORM DRAIN SYSTEM.

GENERAL AND STRUCTURAL NOTES:  
SEE SHEET SD5



BRANDON K. JONES  
PROJECT ENGINEER  
11/28/2023  
DATE

REV.	DATE	APPR.

SCALE:  
N. T.S.

DESIGNED BKJ  
DRAWN BEB  
CHECKED BKJ



**CONSULTING ENGINEERS**  
6080 Fashion Point Drive  
South Ogden, Utah 84403 (801) 476-9767  
www.jonescivil.com

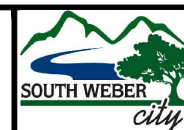

**SOUTH WEBER CITY CORPORATION**  
**PUBLIC WORKS - STORM DRAIN SYSTEM STANDARDS**  
**LARGE DETENTION BASIN DETAILS**

SHEET:  
**SD4**  
OF 34 SHEETS  
0



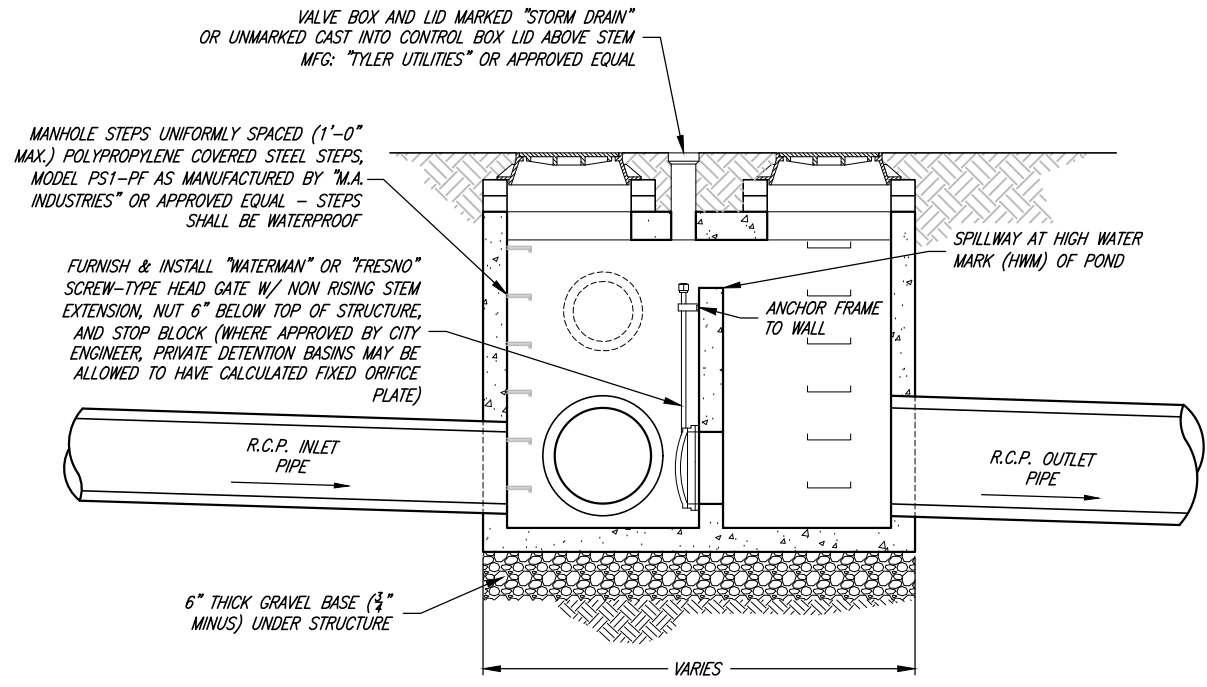

**SECTION B-B**

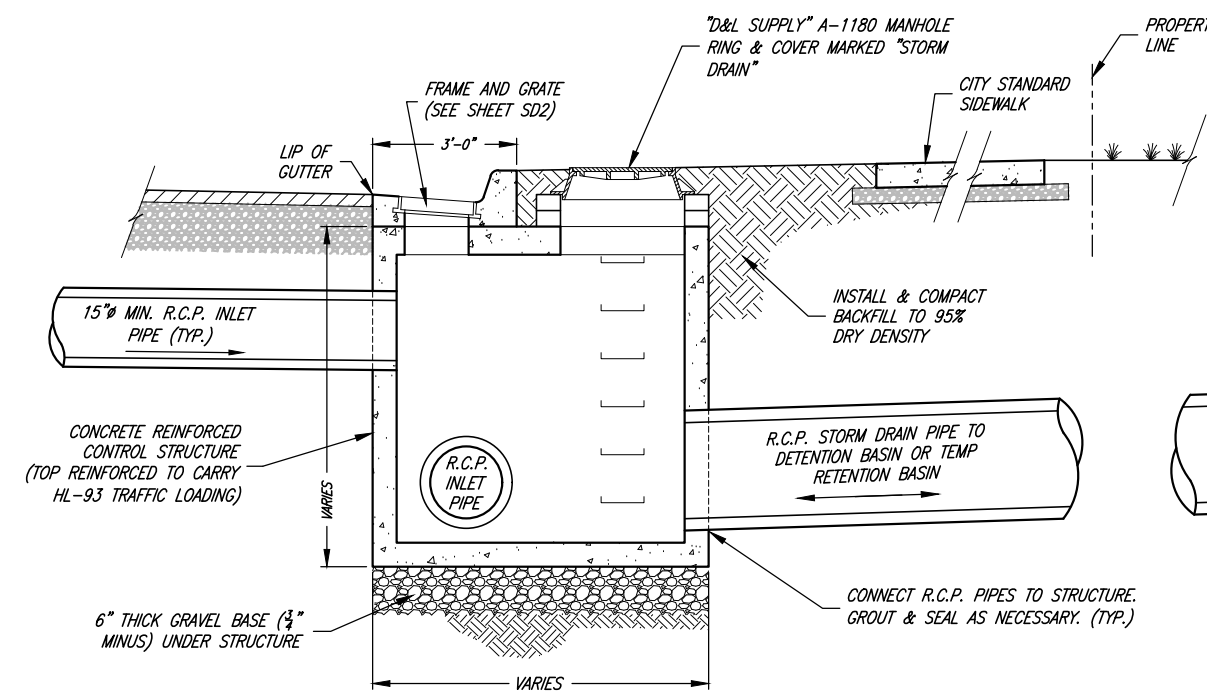

**SECTION A-A**

- GENERAL NOTES:**
- ALL BASINS REGARDLESS OF LOCAL OR REGIONAL SHALL BE DESIGNED TO ACCOMMODATE A 100 YEAR STORM EVENT.
  - A DAM SAFETY (UTAH DIVISION OF WATER RIGHTS) HAZARD PERMIT MAY BE REQUIRED.
  - STRUCTURE DESIGN AND FLOW CALCULATIONS MUST BE APPROVED BY CITY ENGINEER PRIOR TO CONSTRUCTION.
  - STORM DRAIN LINES SHALL BE 15 INCH MINIMUM DIAMETER REINFORCED CONCRETE PIPE (RCP), OF APPROPRIATE CLASS.
  - THE SURFACE AREA OF THE BASIN SHALL BE SODDED AND SHALL BE PROVIDED WITH AN AUTOMATED SPRINKLER SYSTEM APPROVED BY THE CITY ENGINEER.
  - GRATES SHALL BE REMOVABLE FOR MAINTENANCE PURPOSES
  - GRATES SHALL BE HOT DIPPED GALVANIZED WITH BARS AT MAXIMUM 3 INCH SPACING.
  - LOW FLOWS MUST BE PIPED CONTINUOUSLY TO THE CONTROL STRUCTURE. NO OPEN FLOW IS PERMITTED THROUGH THE BASIN.
  - INCLINED GRATES ARE REQUIRED ON ALL PIPES/INLETS WHERE OPEN CHANNELS, DITCHES, OR PONDS DISCHARGE DIRECTLY INTO THE STORM DRAIN SYSTEM.
  - AN INTERNAL SPILLWAY MAY BE CONSTRUCTED INSIDE THE STRUCTURE DEPENDING ON SITE CONDITIONS AND ELEVATIONS.
  - BASIN STRUCTURES ARE DETERMINED BY THE SIZE OF THE DETENTION BASIN OR AS REQUIRED BY THE CITY ENGINEER. (SEE SHEET SD4 OR SD5)
    - SMALL DETENTION BASIN: LESS THAN OR EQUAL TO 1 ACRE FOOT
    - LARGE DETENTION BASIN: GREATER THAN 1 ACRE FOOT

- STRUCTURAL NOTES:**
- PRECAST CONCRETE STRUCTURE CAN BE REPLACED WITH CAST-IN-PLACE CONCRETE VAULT. SUBMIT ENGINEERED CONSTRUCTION PLANS WITH REBAR DETAILS TO CITY ENGINEER FOR REVIEW AND ACCEPTANCE PRIOR TO CONSTRUCTION.
  - ADD REINFORCEMENT AROUND OPENINGS EQUAL TO REINFORCEMENT DISPLACED BY OPENING.
  - THE PRECAST VAULT MANUFACTURER IS RESPONSIBLE FOR DESIGN RELATED TO TRAFFIC LOADING AND THRUST. VERIFICATION OF PROPER DESIGN MUST BE PROVIDED TO THE CITY BY THE DEVELOPER, CONTRACTOR, OR PROPERTY OWNER AS THE CASE MAY BE.
  - REINFORCEMENT TO CONFORM WITH ASTM A 615 GRADE 60
  - CONCRETE SHALL HAVE A 28-DAY COMPRESSIVE STRENGTH OF 5,000 PSI
  - USE AN AIR-ENTRAINING AGENT ON ALL CONCRETE EXPOSED TO THE WEATHER.
  - HL-93 LOADING

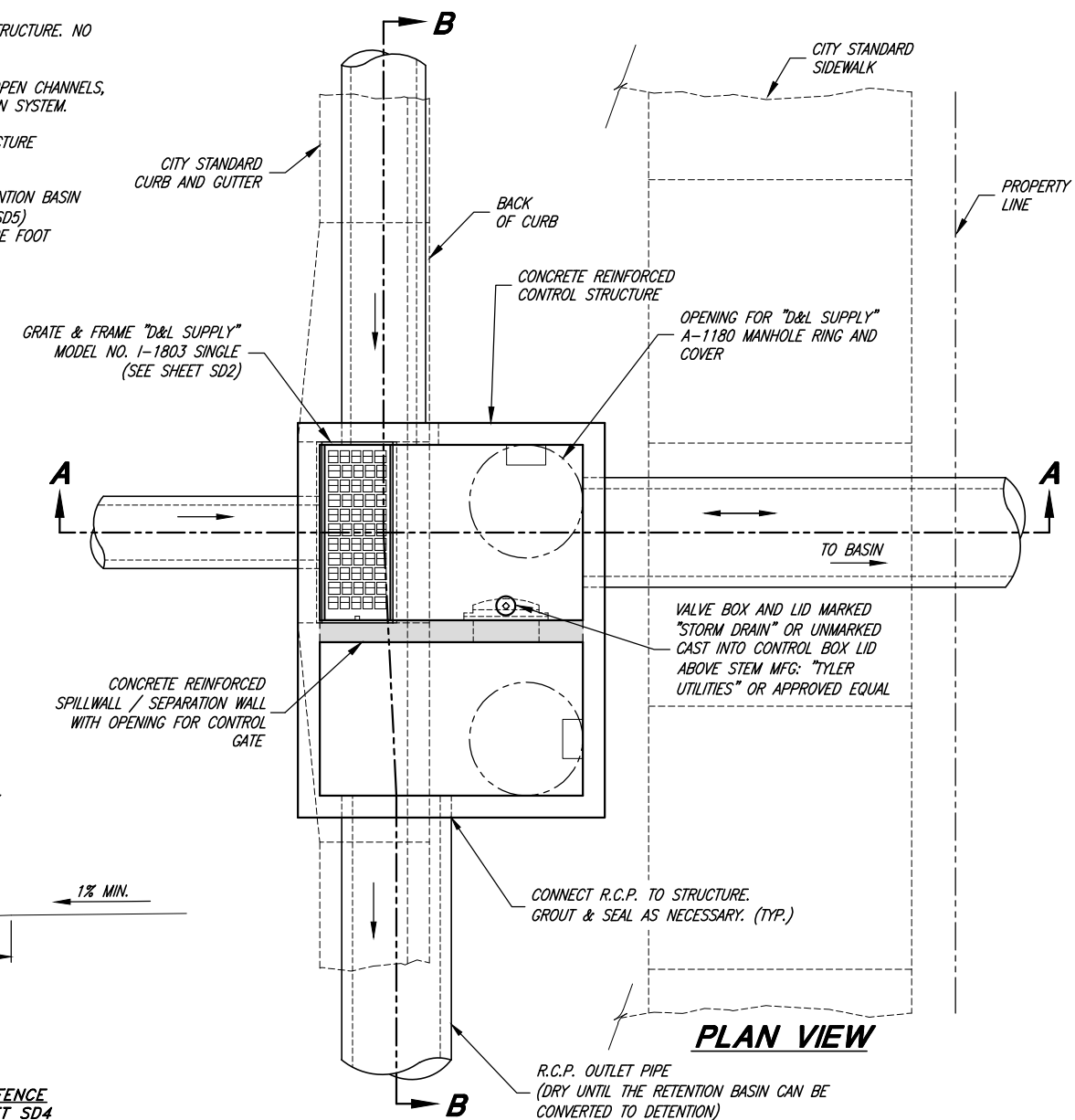

**INLET/OUTLET CONTROL STRUCTURE**

(PRECAST OR CAST-IN-PLACE)



BRANDON KENT JONES  
No. 5148758  
PROJECT ENGINEER  
11/28/2023  
DATE

REV.	DATE	APPR.

SCALE:  
N. T.S.  
DESIGNED BKJ  
DRAWN BEB  
CHECKED BKJ



**CONSULTING ENGINEERS**  
6080 Fashion Point Drive  
South Ogden, Utah 84403 (801) 476-9767  
www.jonescivil.com

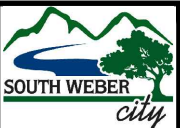

**SOUTH WEBER CITY CORPORATION**  
**PUBLIC WORKS - STORM DRAIN SYSTEM STANDARDS**  
**SMALL DETENTION BASIN DETAILS**

SHEET:  
**SD5**  
OF 34 SHEETS  
0

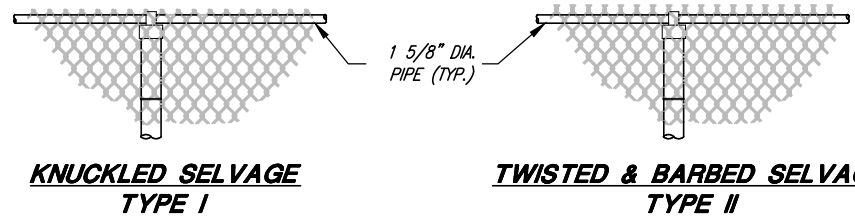

**KNUCKLED SELVAGE TYPE I**

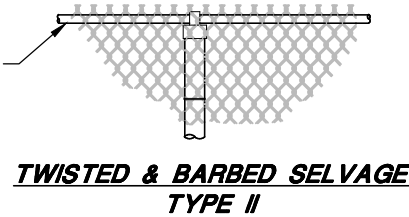

**TWISTED & BARBED SELVAGE TYPE II**

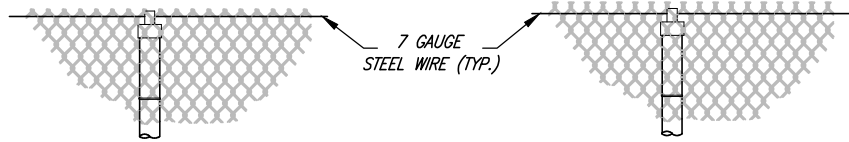

**KNUCKLED SELVAGE W/ TENSION WIRE TYPE III**

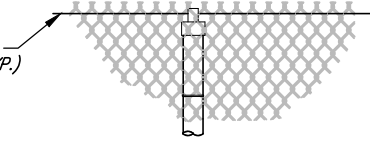

**TWISTED & BARBED SELVAGE W/ TENSION WIRE TYPE IV**

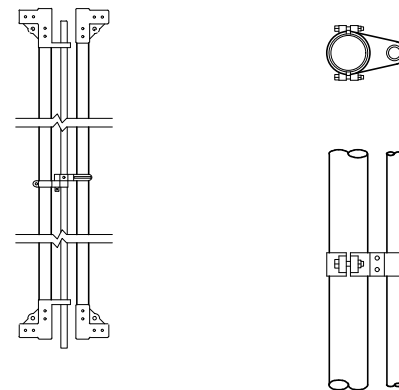

**DROP ROD ASSEMBLY**

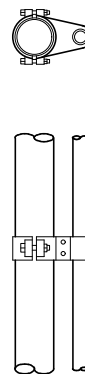

**TOP GATE HINGE**

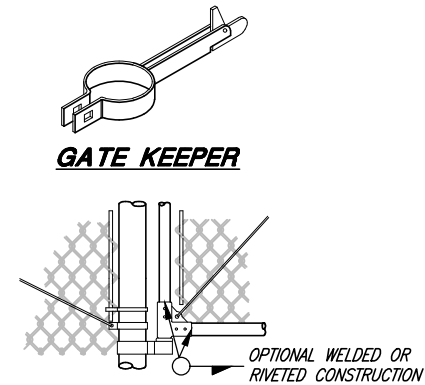

**BOTTOM GATE HINGE AND GATE DETAIL**

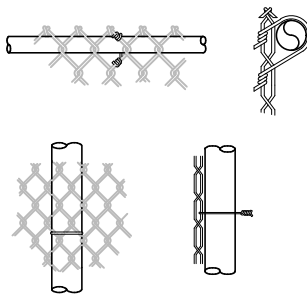

**PIPE POST TIE**

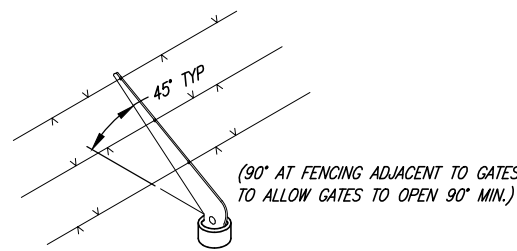

**COMBINATION CAP AND BARBED WIRE SUPPORTING ARM**

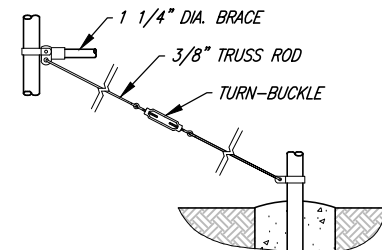

**BRACE & TRUSS CONNECTIONS**

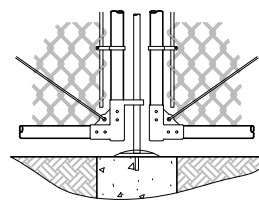

**CENTER GATE STOP AND GATE DETAIL**

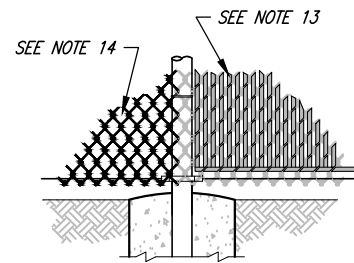

**SLATS & VINYL COATING DETAIL**

**GENERAL NOTES:**

1. MATERIALS, CONSTRUCTION, AND WORKMANSHIP SHALL BE IN ACCORDANCE WITH MANUFACTURER'S RECOMMENDATIONS.
2. TOP SUPPORT - TYPES I AND II TUBULAR RAIL, TYPES III AND IV TENSION WIRE.
3. BARB WIRE SHALL ONLY BE USED WHEN APPROVED BY THE CITY.
4. TWISTED AND BARBED SELVAGE TOP AND BOTTOM SHALL BE USED ON FENCES 5- FEET HIGH OR GREATER.
5. KNUCKLED SELVAGE ON TOP AND TWISTED AND BARBED ON BOTTOM SHALL BE USED ON FENCES LESS THAN 5- FEET.
6. ALL STEEL PIPE MEMBERS SHALL CONFORM TO ASTM A53 HOT DIPPED ZINC COATED HIGH TENSILE STEEL PIPE.
7. POSTS SHALL BE SCHEDULE 40 PIPE.
8. LINE POSTS SHALL BE LOCATED AT EQUAL SPACING FOR EACH SEGMENT WITH A MAXIMUM SPACING AS FOLLOWS:
  - a. TANGENT SECTIONS TO 500-FOOT RADIUS NOT MORE THAN 8- FEET.
  - b. UNDER 500-FOOT RADIUS TO 200-FOOT RADIUS NOT MORE THAN 8- FEET.
  - c. UNDER 200-FOOT RADIUS TO 100-FOOT RADIUS NOT MORE THAN 6- FEET.
  - d. UNDER 100-FOOT RADIUS NOT MORE THAN 5- FEET.
9. TRUSS RODS AND BRACES SHALL NOT BE REQUIRED FOR FABRIC HEIGHT LESS THAN 5- FEET.
10. TENSION WIRE SHALL BE 7 GAUGE ZINC- OR ALUMINUM- COATED COIL SPRING STEEL TENSION WIRE.
11. ALL POSTS SHALL BE SET IN 3000 PSI CONCRETE AND SHALL BE TOPPED WITH BALL TYPE OR OTHER APPROVED ORNAMENT.
12. ALL FABRIC SHALL BE 2" GALVANIZED 9 GAUGE MESH.
13. WHITE VERTICAL SEMI-PRIVACY VINYL SLATS WITH BOTTOM-LOCKING SLAT, WHEN REQUIRED BY THE CITY.
14. BLACK VINYL COATED CHAIN LINK FENCING WHEN REQUIRED BY THE CITY.
15. ALL FENCING SHALL CONFORM TO LOCATION AND HEIGHT LIMITATIONS AS STATED IN SOUTH WEBER CITY FENCING ORDINANCE.

HEIGHT	GATE OPENING	GATE POST	GATE FRAME
UNDER 6 FEET	SINGLE TO 6' OR DOUBLE TO 12'	2"	1"
	SINGLE OVER 6' TO 8' OR DOUBLE OVER 12' TO 16'	2 1/2"	
	SINGLE OVER 8' TO 12' OR DOUBLE 16' TO 24'	4"	1 1/2"
6 FEET AND OVER	SINGLE TO 6' OR DOUBLE TO 12'	3 1/2"	
	SINGLE OVER 6' TO 12' OR DOUBLE OVER 12' TO 24'	4"	1 1/2"
	SINGLE OVER 12' TO 18' OR DOUBLE OVER 24' TO 36'	6"	
	SINGLE OVER 18' OR DOUBLE OVER 36'	8"	

HEIGHT OF FABRIC	DEPTH OF POSTS	LENGTH OF END, CORNER OR PULL POST	LENGTH OF LINE POST	SIZE OF POSTS	
				END, CORNER, & PULL POSTS	LINE POST
				NOM. SIZE	NOM. SIZE
7'	3'	10'	9'-8"	2 1/2"	2"
6'	3'	9'	8'-8"	2 1/2"	2"
5'	3'	8'	7'-8"	2"	1 1/2"
4'	2'	6'	5'-8"	2"	1 1/2"
3'	2'	5'	4'-8"	2"	1 1/2"

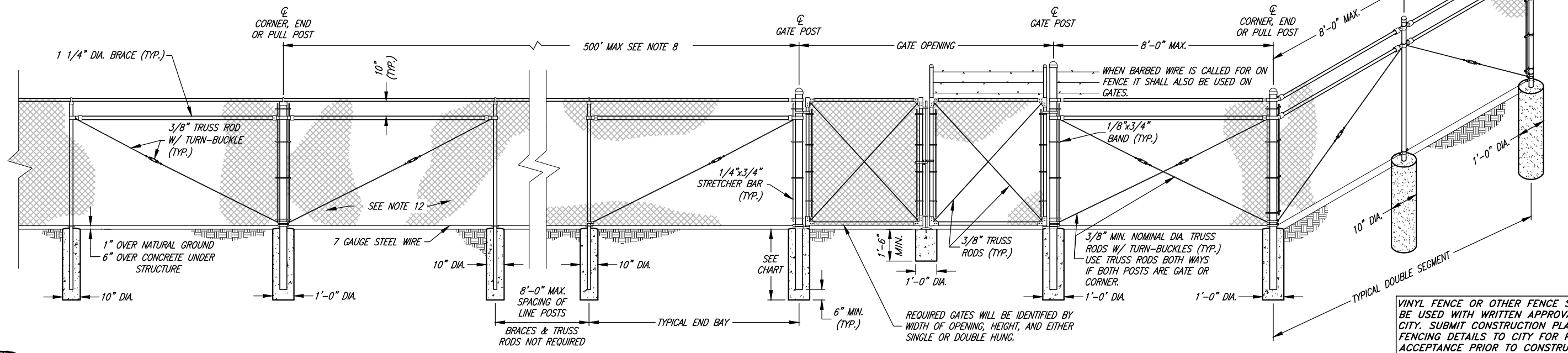

VINYL FENCE OR OTHER FENCE STYLES MAY BE USED WITH WRITTEN APPROVAL BY THE CITY. SUBMIT CONSTRUCTION PLANS AND FENCING DETAILS TO CITY FOR REVIEW AND ACCEPTANCE PRIOR TO CONSTRUCTION.



BRANDON K. JONES  
PROJECT ENGINEER  
11/28/2023  
DATE

SCALE: N.T.S.  
DESIGNED: BKJ  
DRAWN: BEB  
CHECKED: BKJ

**JA JONES & ASSOCIATES**  
CONSULTING ENGINEERS  
6080 Fashion Point Drive  
South Ogden, Utah 84403 (801) 476-9767  
www.jonescivil.com

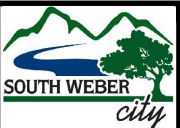

**SOUTH WEBER CITY CORPORATION**  
PUBLIC WORKS - GENERAL CONSTRUCTION & LANDSCAPING STANDARDS  
**CHAIN LINK FENCE STANDARD DETAILS**

SHEET: **G1**  
OF 34 SHEETS  
0



**WATER EFFICIENT (WATER WISE) LANDSCAPING:**

1. **PURPOSE:**

THE PURPOSE OF THESE WATER EFFICIENCY STANDARDS IS TO CONSERVE THE PUBLIC'S WATER RESOURCES BY ESTABLISHING WATER CONSERVATION STANDARDS FOR OUTDOOR LANDSCAPING.

2. **REFER TO SOUTH WEBER CITY CODE TITLE 10 CHAPTER 15 – WATER EFFICIENT LANDSCAPE REQUIREMENTS**

3. **"WATER WISE LANDSCAPING"**

A. **LANDSCAPES IN EXISTING SINGLE-FAMILY RESIDENTIAL DEVELOPMENTS:** "WATER WISE LANDSCAPING" IS RECOMMENDED BUT NOT REQUIRED.

B. **LANDSCAPES IN NEW SINGLE-FAMILY RESIDENTIAL DEVELOPMENTS:** SEE CITY CODE TITLE 10 CHAPTER 15

C. **LANDSCAPES IN ALL OTHER TYPES OF DEVELOPMENTS:** SEE CITY CODE TITLE 10 CHAPTER 15

4. **ADDITIONAL "WATER WISE LANDSCAPING" RESOURCES: REFER TO THE FOLLOWING WEBSITES:**

- a. <https://localscapes.com>
- b. <https://conservationgardenpark.org>
- c. <https://extension.usu.edu/cwel/principles>

ALL WATER METERS TO BE CLEAR AND ACCESSIBLE  
(DO NOT BURY OR PLACE ANYTHING ON TOP OF THE METER LID)

**DISCLAIMER:**  
THE "WATER WISE LANDSCAPING" EXAMPLES SHOWN ON THIS SHEET ARE POSSIBLE RECOMMENDATIONS FOR USE WITHIN THE CITY. ANY SPECIFIC WEBSITES, COMMERCIAL PRODUCTS, PROCESS OR SERVICE BY TRADE NAME, TRADEMARK, MANUFACTURER, OR OTHERWISE, DOES NOT CONSTITUTE OR IMPLY ITS ENDORSEMENT, RECOMMENDATION, OR FAVORING BY SOUTH WEBER CITY. THE PURPOSE OF PROVIDING SPECIFIC PRODUCT INFORMATION IS TO ENSURE THAT THE PROPERTY OWNER, CONTRACTOR AND/OR DEVELOPER HAS ALL THE APPROPRIATE INFORMATION AND REFERENCES TO ASSESS THE USEFULNESS OF THE PRODUCT.

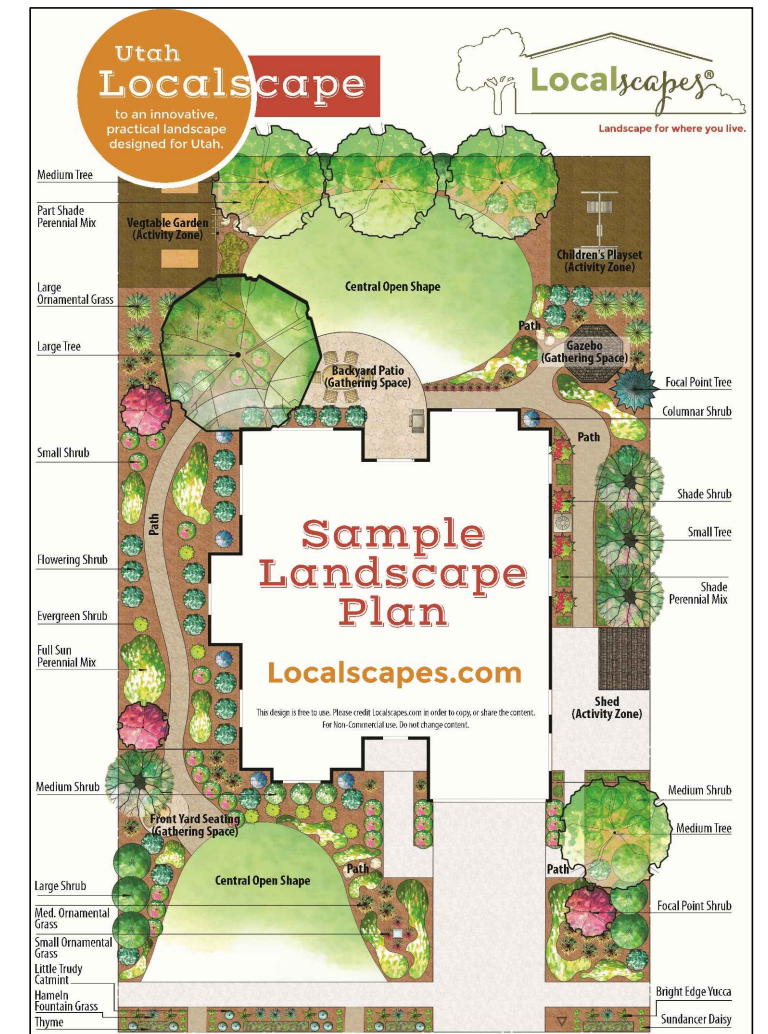

<https://localscapes.com>  
<https://conservationgardenpark.org>  
<https://extension.usu.edu/cwel/principles>



BRANDON KENT JONES  
No. 5148758  
PROJECT ENGINEER  
11/28/2023  
DATE

REV.	DATE	APPR.

SCALE:  
N. T.S.

DESIGNED BKJ  
DRAWN BEB  
CHECKED BKJ



**CONSULTING ENGINEERS**  
6080 Fashion Point Drive  
South Ogden, Utah 84403 (801) 476-9767  
[www.jonescivil.com](http://www.jonescivil.com)

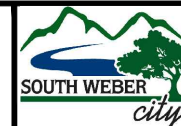

**SOUTH WEBER CITY CORPORATION**  
**PUBLIC WORKS - GENERAL CONSTRUCTION & LANDSCAPING STANDARDS**  
**WATER EFFICIENT LANDSCAPING**

SHEET:  
**G2**  
OF 34 SHEETS  
0



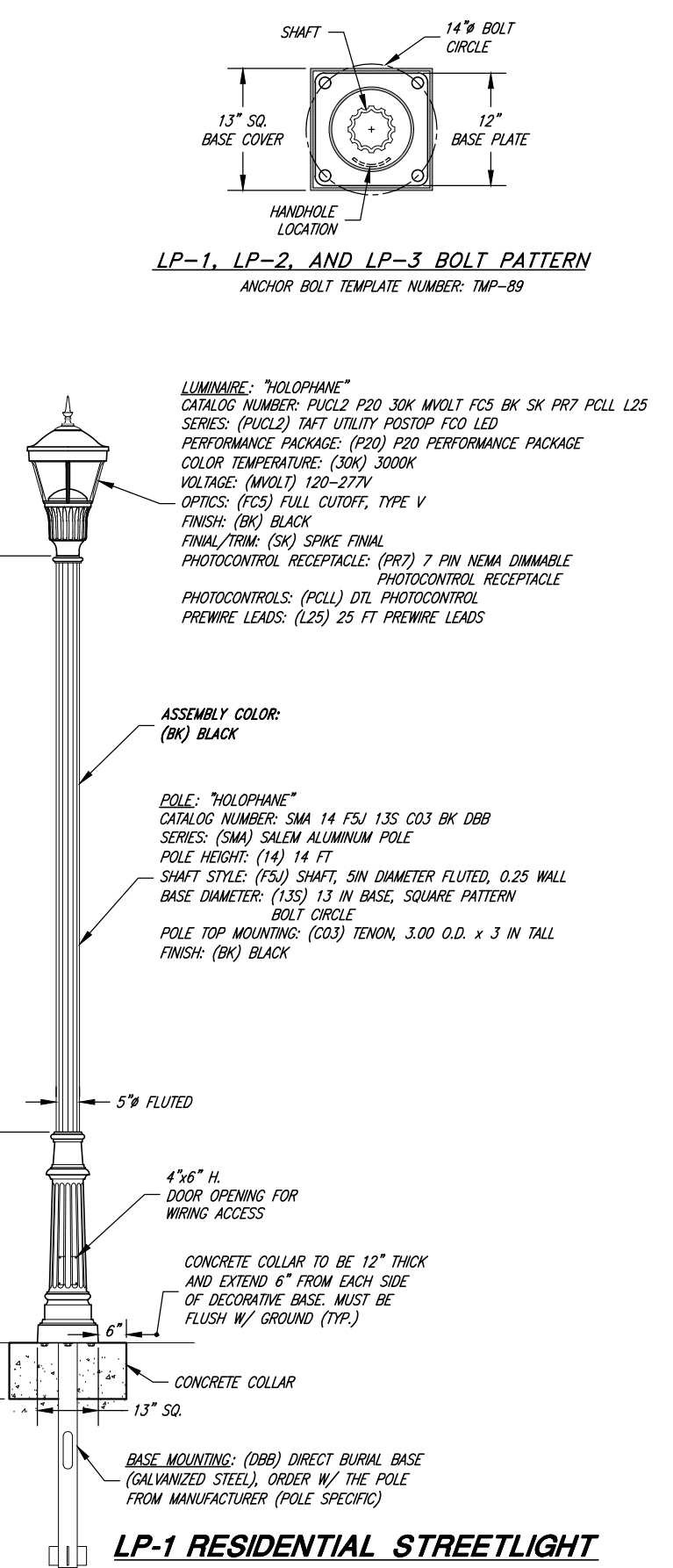
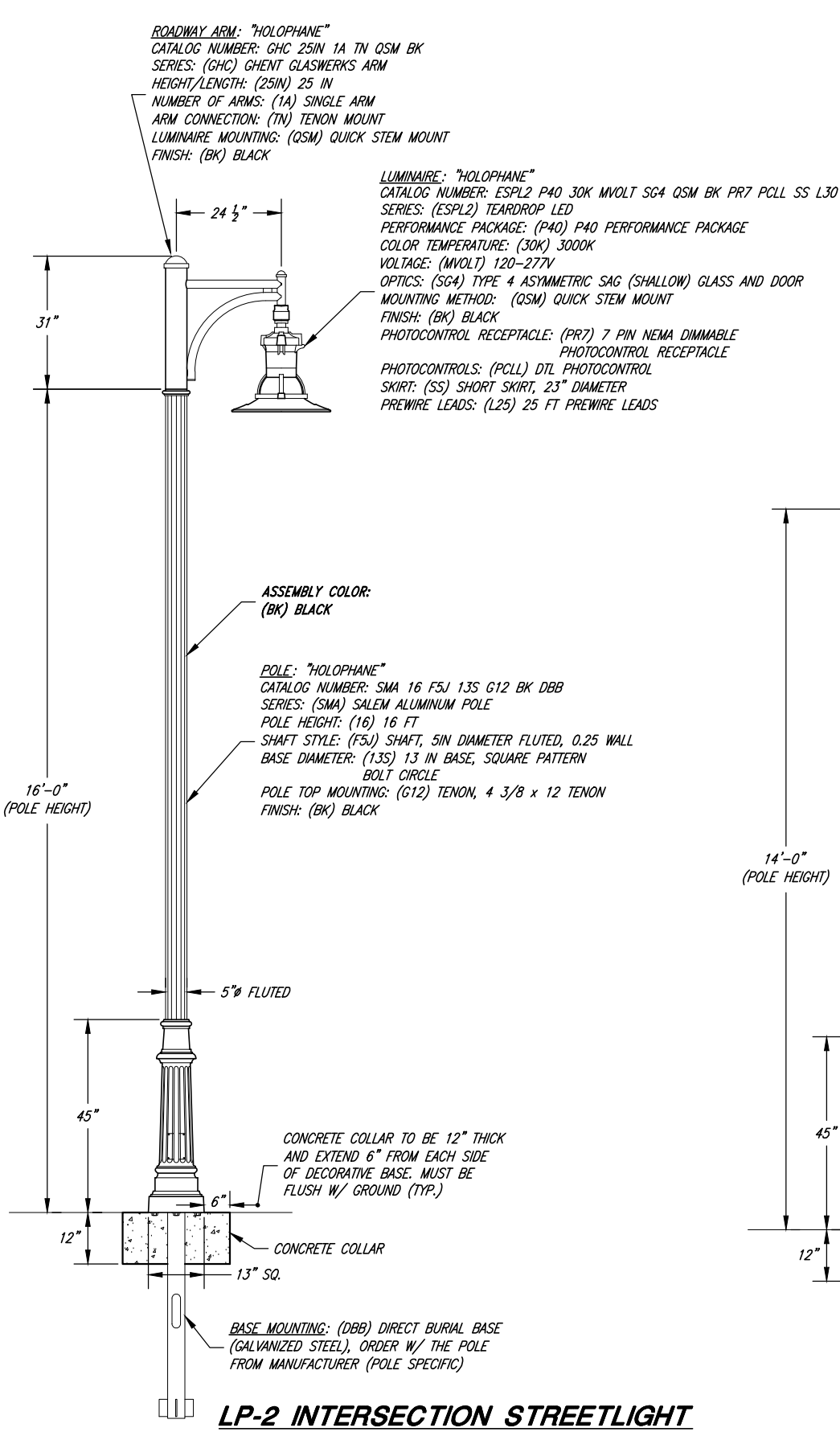
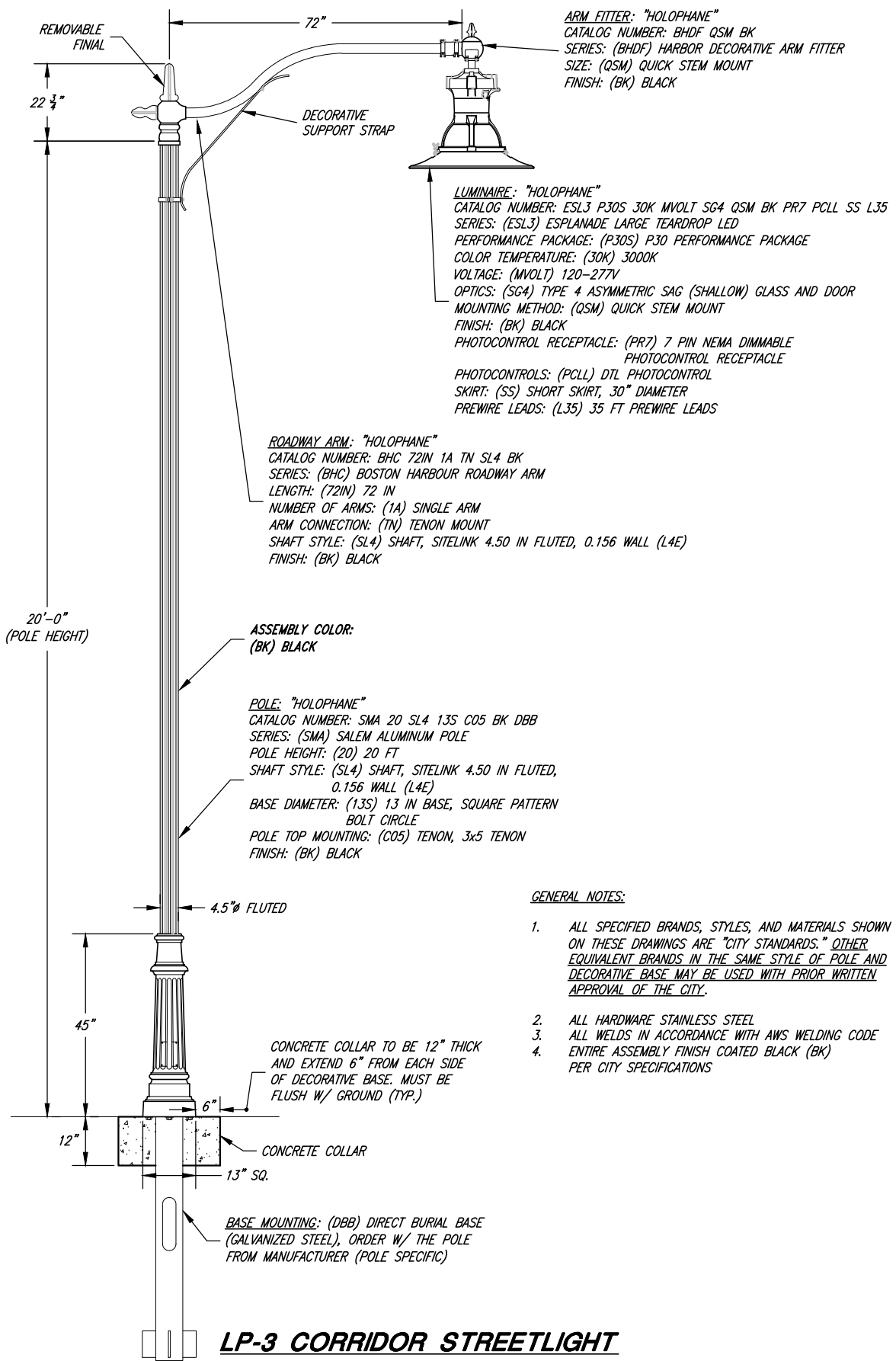

- GENERAL NOTES:**
1. ALL SPECIFIED BRANDS, STYLES, AND MATERIALS SHOWN ON THESE DRAWINGS ARE "CITY STANDARDS." OTHER EQUIVALENT BRANDS IN THE SAME STYLE OF POLE AND DECORATIVE BASE MAY BE USED WITH PRIOR WRITTEN APPROVAL OF THE CITY.
  2. ALL HARDWARE STAINLESS STEEL
  3. ALL WELDS IN ACCORDANCE WITH AWS WELDING CODE
  4. ENTIRE ASSEMBLY FINISH COATED BLACK (BK) PER CITY SPECIFICATIONS



BRANDON KENT JONES  
No. 5148758  
REGISTERED PROFESSIONAL ENGINEER  
State of Utah  
PROJECT ENGINEER  
11/28/2023  
DATE

REV.	DATE	APPR.

SCALE:  
N. T.S.

DESIGNED: BKJ  
DRAWN: BEB  
CHECKED: BKJ

**JA JONES & ASSOCIATES**  
CONSULTING ENGINEERS  
6080 Fashion Point Drive  
South Ogden, Utah 84403 (801) 476-9767  
www.jonescivil.com

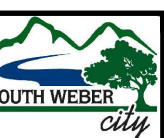

**SOUTH WEBER CITY CORPORATION**  
PUBLIC WORKS - STREET LIGHTING STANDARDS  
**POLES AND FIXTURES**

SHEET:  
**SL1**  
OF 34 SHEETS  
0

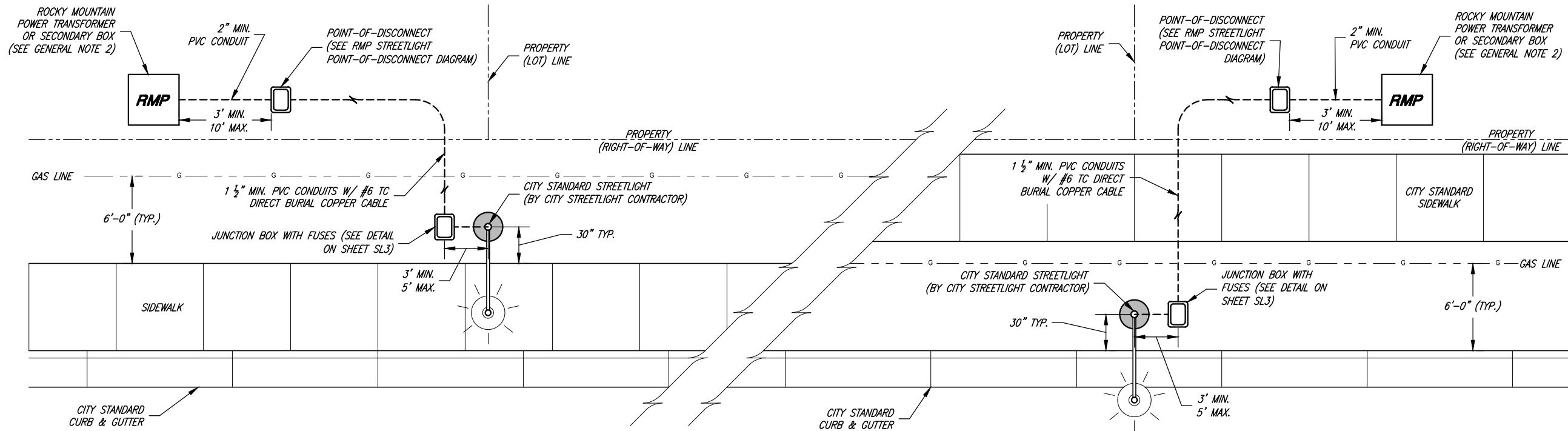

**TYPICAL CONDUIT AND POWER LAYOUT "B"**  
(STANDARD LOCAL STREET SECTION WITHOUT PARKSTRIP)

**TYPICAL CONDUIT AND POWER LAYOUT "A"**  
(STANDARD LOCAL STREET SECTION WITH PARKSTRIP)

**GENERAL NOTES:**

- FOR THE STREETLIGHT DESIGN STANDARDS AND SPECIFICATIONS REFER TO THE APPLICABLE SECTIONS IN THE SOUTH WEBER CITY DEVELOPMENT, DESIGN & CONSTRUCTION STANDARDS.
- DEVELOPER/CONTRACTOR SHALL CONSULT THE POWER COMPANY ON THE JUNCTION BOX LOCATION, PEDESTAL LOCATION, CONDUIT LOCATION, AND DIGGING PRIOR TO INSTALLATION.
- WHERE POSSIBLE, LOCATE STREETLIGHT CONDUIT PARALLEL WITH RMP CONDUIT.
- JUNCTION BOX CONNECTING TO STREETLIGHT MAY ALSO SERVE AS POINT-OF-DISCONNECT IF LOCATED WITHIN 10' FROM THE POWER SOURCE.

**GENERAL NOTES CONT.:**

- INGROUND BOXES LOCATED WITHIN 20' OF APPROACHES OR INTERSECTIONS SHALL BE TRAFFIC RATED. WHERE APPROVED BY THE CITY ENGINEER, ANY BOX INSTALLATION IN SIDEWALK OR CONCRETE WILL REQUIRE THE GROUND BOX TO BE DESIGNED AND LISTED FOR USE IN CONCRETE. SUBMIT BOX SPECIFICATIONS TO CITY ENGINEER FOR APPROVAL PRIOR TO INSTALLATION. ALL BOXES SHALL HAVE THE WORDS "SOUTH WEBER STREET LIGHTING" ON THE COVER.
- FLAT PULL LINE CAPABLE OF WITHSTANDING 1000 LBS OF TENSION, INSTALLED WITH 72 INCHES OF EXTRA LINE CAPABLE OF EXTENDING FROM EACH END OF CONDUIT. THE PULL LINE SHALL BE SECURED INSIDE THE ENDS OF THE CONDUIT AND BOTH ENDS SHALL BE CAPPED.
- CONDUIT SHALL EXTEND A MAX. OF 3 INCHES ABOVE THE GRAVEL IN THE BASE OF THE GROUND BOX AND A MINIMUM OF 2" ABOVE THE GRAVEL.

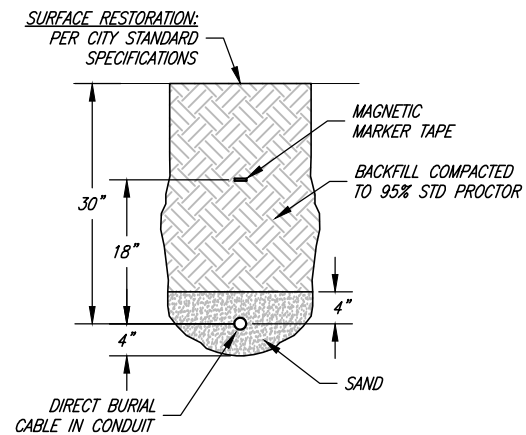

**TYPICAL TRENCH DETAIL**

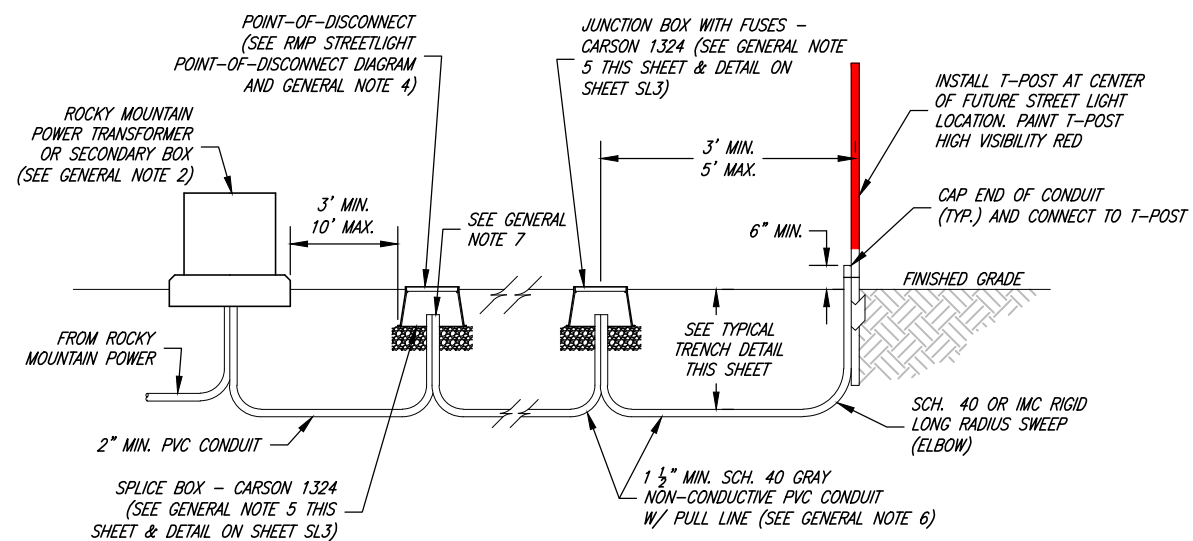
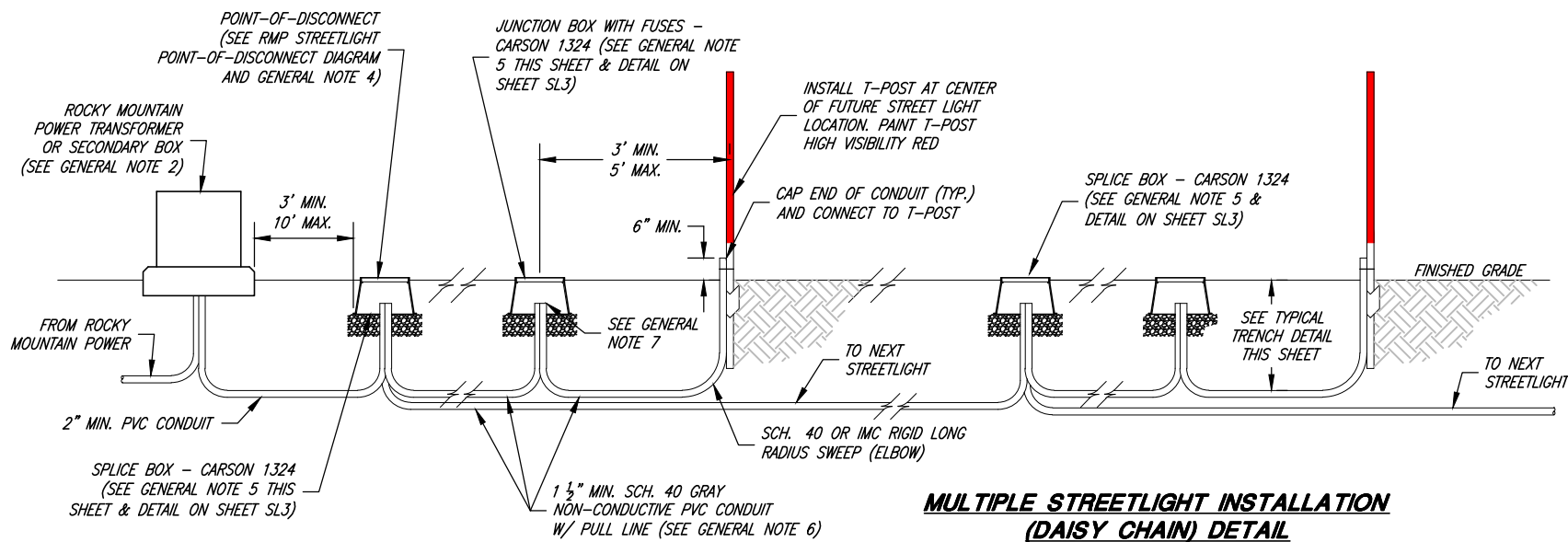

**TYPICAL STREETLIGHT INSTALLATION**



BRANDON KENT JONES  
No. 5148758  
State of Utah  
PROJECT ENGINEER  
11/28/2023  
DATE

REV.	DATE	APPR.

SCALE:  
N. T.S.

DESIGNED BKJ  
DRAWN BEB  
CHECKED BKJ

**J&A JONES & ASSOCIATES**

CONSULTING ENGINEERS

6080 Fashion Point Drive  
South Ogden, Utah 84403 (801) 476-9767  
www.jonescivil.com

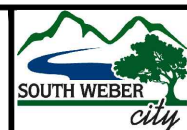

**SOUTH WEBER CITY CORPORATION**  
PUBLIC WORKS - STREET LIGHTING STANDARDS  
DEVELOPER/CONTRACTOR INSTALLATION PORTION  
OF STREETLIGHT STANDARDS

SHEET:  
**SL2**  
OF 34 SHEETS  
0



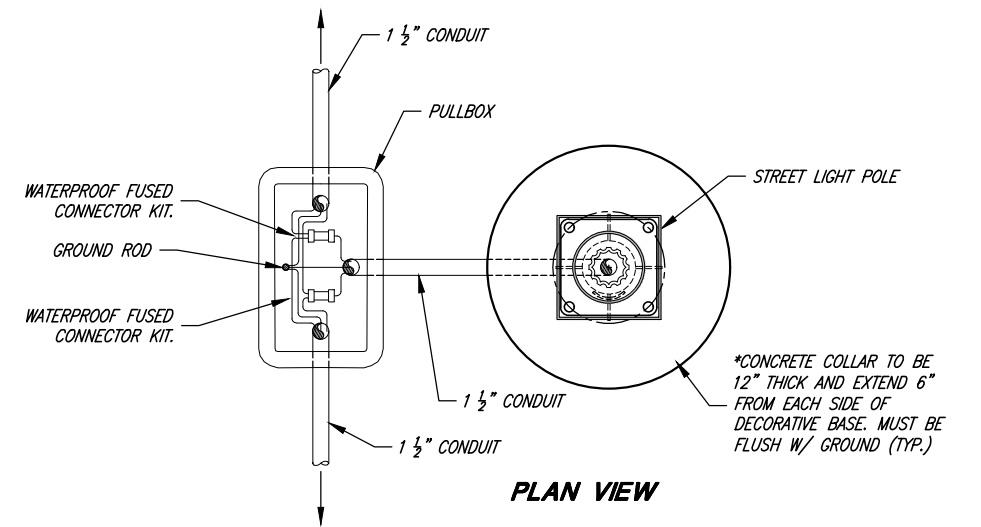
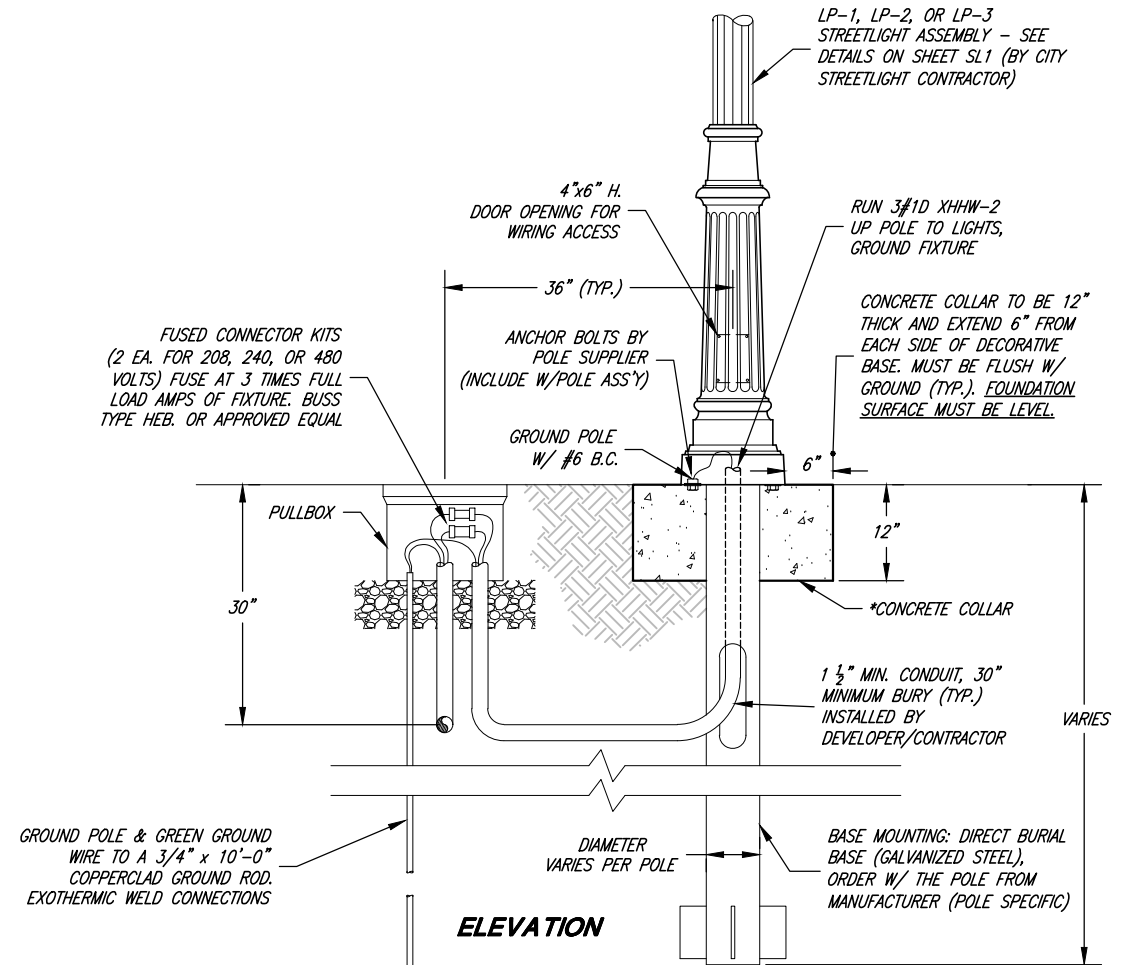
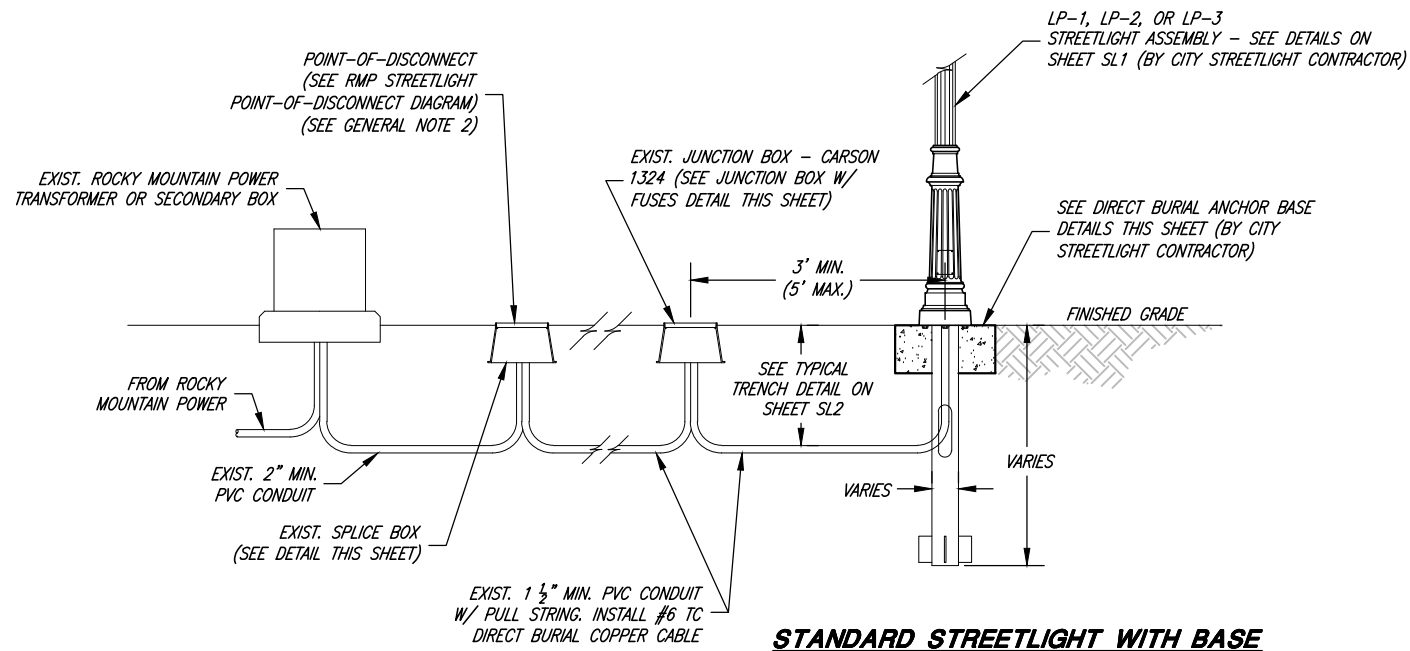
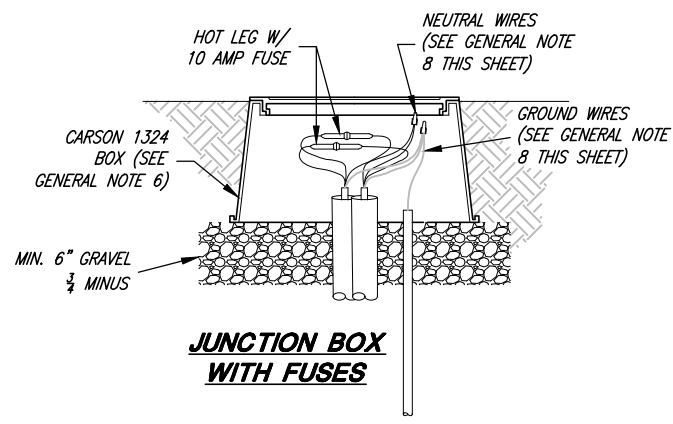
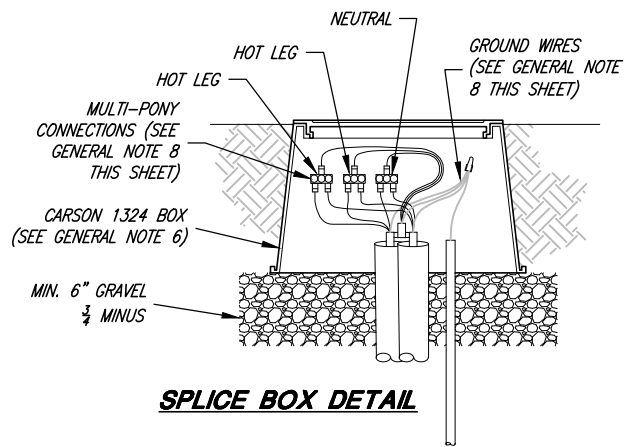

**STREET LIGHT POLE, DIRECT BURIAL ANCHOR BASE AND PULL BOX**

N.T.S.

\* CONCRETE CLASS 4000 PER APWA 03 30 04, PLACEMENT PER APWA 03 30 10, AND CURE PER APWA 03 39 00

**GENERAL NOTES:**

- EACH LIGHT POLE ASSEMBLY SHALL HAVE A JUNCTION BOX WITH FUSES. FUSE HOT WIRES IN JUNCTION BOXES, SUPPLY SPLICE KIT FOR NEUTRAL CABLE.
- LEAVE PIGTAIL 8 FEET LONG TO SECONDARY BOX; ROCKY MOUNTAIN POWER TO MAKE CONNECTION.
- ALL CONDUCTORS SHALL BE OKONITE-FMR TYPE TC-CABLE #112-10-4054; OKONITE X-OLENE OKOSEAL #112-31-3747; OR ANIXTER VNTC #3H-0603 COPPER ONLY.
- FUSE HOLDERS SHALL BE IN-LINE, WATER TIGHT LEC-AA
- WIRE MUST EXTEND 18 INCHES ABOVE GRADE TO SPLICE IN GROUND BOX.
- CARSON 1324 BOX SPECIFICATIONS:
  - 12" DEPTH (TYP.)
  - FLUSH SOLID LID
  - COLOR OPTION BLACK
  - LID SECURED WITH STAINLESS STEEL HEX BOLTS
  - LID MUST SPECIFY "SOUTH WEBER STREET LIGHTING"
- ALL BELOW GRADE SPLICING / FUSES SHALL BE WATERTIGHT.
- IN BOX CONNECTIONS:
  - USE "BURNDY" BIBS350JDB, DIRECT BURIAL SUBMERSIBLE THREE CONDUCTOR INSULATED MULTI-TAP CONNECTOR FOR IN BOX CONNECTIONS WHERE A FUSE KIT IS NOT NEEDED.
  - WIRE NUTS SHALL NOT BE ALLOWED FOR CONNECTIONS IN GROUND BOXES. WIRE NUTS MAY ONLY BE USED FOR CONNECTIONS IN THE BASE OF POLES.



BRANDON KENT JONES  
No. 5148758  
PROJECT ENGINEER  
11/28/2023  
DATE

REV.	DATE	APPR.

SCALE:  
N. T.S.

DESIGNED BKJ  
DRAWN BEB  
CHECKED BKJ



**CONSULTING ENGINEERS**  
6080 Fashion Point Drive  
South Ogden, Utah 84403 (801) 476-9767  
www.jonescivil.com

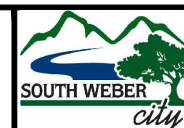

**SOUTH WEBER CITY CORPORATION**  
**PUBLIC WORKS - STREET LIGHTING STANDARDS**  
**CITY CONTRACTOR INSTALLATION PORTION**  
**OF STREETLIGHT STANDARDS**

SHEET:  
**SL3**  
OF 34 SHEETS  
0

**Figure 63—Street Lighting Points of Connection Diagram**

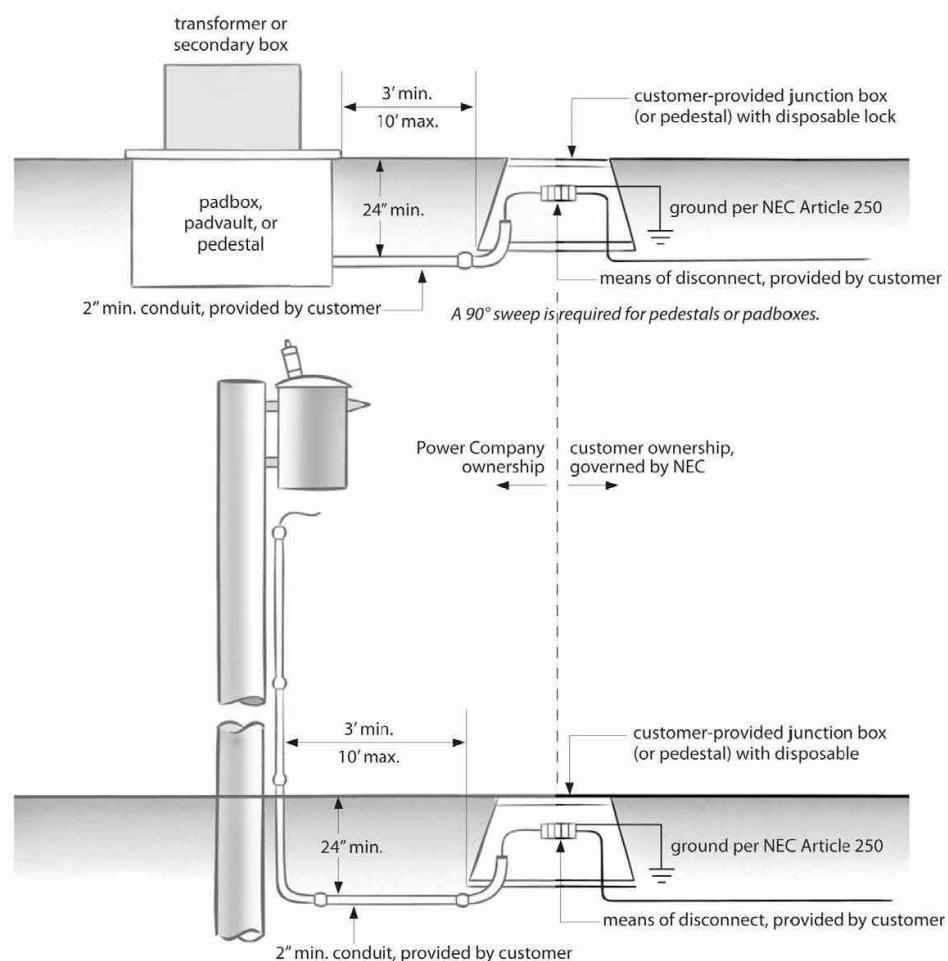

More information on streetlights is posted online at: <https://www.pacificpower.net/working-with-us/municipalities.html> and <https://www.rockymountainpower.net/working-with-us/municipalities.html>.

**GENERAL NOTE:**

REFER TO THE MOST RECENT EDITION OF THE ROCKY MOUNTAIN POWER ELECTRIC SERVICE REQUIREMENTS MANUAL FOR GUIDANCE AND INSTRUCTIONS ON ELECTRIC SERVICE REQUIREMENTS.

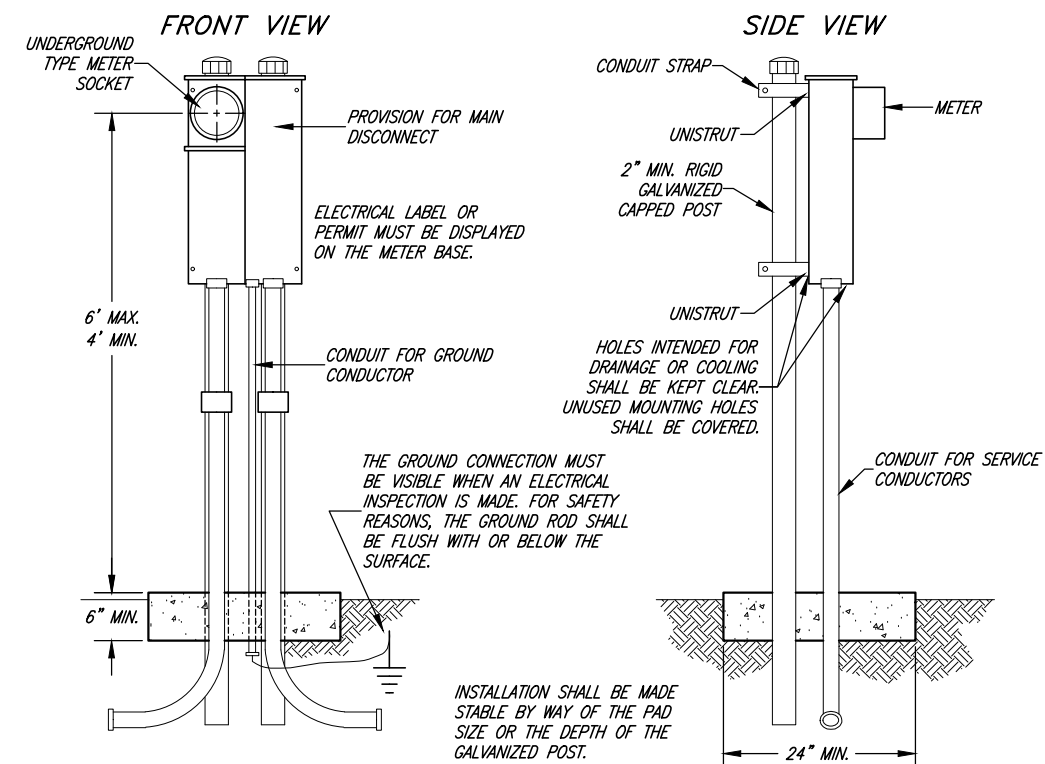

**UNDERGROUND SERVICE TO A FREE-STANDING METER BASE**

(STEEL POLE)  
INSTALLATION PER ROCKY MOUNTAIN POWER ELECTRIC SERVICE REQUIREMENTS MANUAL

**DEVELOPER/CONTRACTOR WILL FURNISH AND INSTALL:**

- A. METER SOCKET ENCLOSURE (UNDERGROUND TYPE WITH MANUAL-LINK BYPASS)
- B. PEDESTAL HARDWARE
- C. CONDUIT
- D. RIGHT-OF-WAY OR EASEMENT
- E. TRENCH EXCAVATION AND BACKFILL
- F. GROUNDING PER NEC
- G. CONCRETE PAD 24" x 24" x 6" DEPTH
- H. LONG RADIUS SWEEP
- I. 36" SWEEP

**FREE-STANDING METER BASE REQUIREMENTS:**

- A1. THE DEVELOPER/CONTRACTOR SHALL MEET WITH THE POWER COMPANY TO DETERMINE THE LOCATION OF THE FREE-STANDING METER BASE.
- B1. THE FREE-STANDING METER BASE SHALL BE LOCATED ADJACENT TO, OR IN, THE POWER COMPANY EASEMENT.
- C1. THE FREE-STANDING METER BASE SHALL MEET ALL LOCAL ORDINANCE REQUIREMENTS.
- D1. THE METER SOCKET SHALL BE PROTECTED FROM DAMAGE BY USE OF BARRIER POSTS OR OTHER SUITABLE PROTECTION APPROVED BY THE POWER COMPANY.
- E1. THE DEVELOPER/CONTRACTOR SHALL FURNISH, INSTALL AND MAINTAIN AN APPROVED PEDESTAL OR POLE POST.
- F1. THE ACCESS DOOR TO POWER COMPANY CONNECTIONS SHALL BE KEPT FREE OF OBSTRUCTIONS A MINIMUM OF 6" ABOVE THE FINAL GRADE, WITH A SEALABLE PROVISION FOR THE POWER COMPANY.
- G1. THE UNMETERED SERVICE CONDUCTOR AND THE METERED SERVICE CONDUCTOR SHALL NOT BE RUN IN THE SAME CONDUIT, RACEWAY, OR GUTTER.
- H1. THE METER SOCKET AND SERVICE EQUIPMENT SHALL BE NEMA TYPE 3R (RAINPROOF), IN GOOD CONDITION WITH NO HOLES, DENTS OR DAMAGE, AND PLUMB IN ALL DIRECTIONS. THE INSTALLATION SHALL BE MADE WITH SUFFICIENT MATERIALS AND INSTALLED SUCH THAT IT REMAINS PLUMB FOR THE DURATION OF THE SERVICE.
- I1. CONDUIT AND CONDUCTOR TRENCHERS SHALL BE LOCATED AWAY FROM (AND NEVER UNDERNEATH) THE PAD AND FOUNDATION. FOR MOBILE HOMES, TRENCHES SHALL BE LOCATED CLEAR OF THE AREA PROVIDED FOR THE DWELLING.
- J1. WHERE TWO OR MORE METERS ARE LOCATED SIDE-BY-SIDE (SUCH AS WITH DUPLEXES OR IN MOBILE HOME PARKS), THE METER SOCKET ENCLOSURE SHALL BE PERMANENTLY LABELED WITH THE SPACE OR BERTH NUMBERS.



This manual shall be distributed and interpreted in its entirety. Individual pages will not represent all the requirements necessary for an installation. © 2019 PacifiCorp.



*Brandon K. Jones*  
PROJECT ENGINEER  
11/28/2023  
DATE

REV.	DATE	APPR.

SCALE:  
N. T.S.  
DESIGNED BKJ  
DRAWN BEB  
CHECKED BKJ



**CONSULTING ENGINEERS**  
6080 Fashion Point Drive  
South Ogden, Utah 84403 (801) 476-9767  
[www.jonescivil.com](http://www.jonescivil.com)

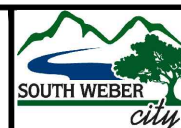

**SOUTH WEBER CITY CORPORATION**  
**PUBLIC WORKS - STREET LIGHTING STANDARDS**  
**ROCKY MOUNTAIN POWER CONNECTION DETAILS**

SHEET:  
**SL4**  
OF 34 SHEETS  
0



FOR RAIN GARDEN DETAIL, SEE UTAH LOW IMPACT DEVELOPMENT GUIDE (REVISED: AUGUST 2020) DWQ-2019-000161 (SECTION BR-1 PAGE C-3)

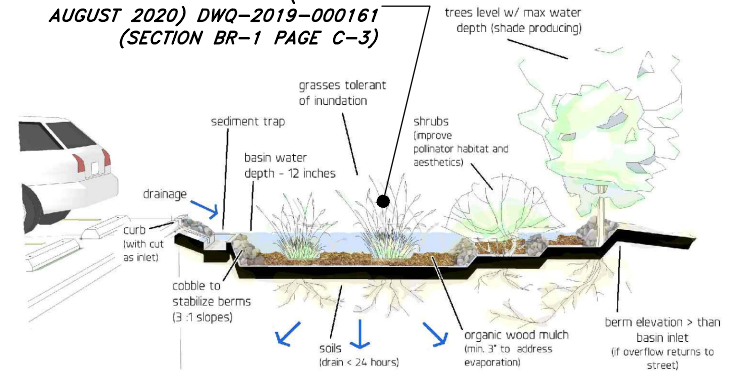

Basic Basin Design Considerations

**RAIN GARDEN**  
 \*\*\* [http://www.lid-stormwater.net/site\\_map.htm](http://www.lid-stormwater.net/site_map.htm) \*\*\*

diagram by Paul Navrot for SUH

FOR TREE BOX FILTER DETAIL, SEE UTAH LOW IMPACT DEVELOPMENT GUIDE (REVISED: AUGUST 2020) DWQ-2019-000161 (SECTION BR-5 PAGE C-28)

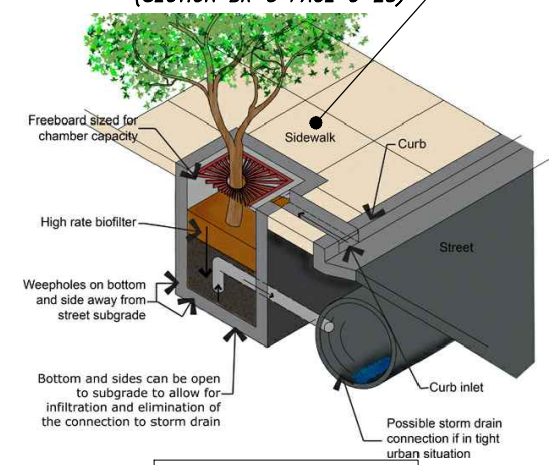

**TREE BOX FILTER**  
 From [www.wbdg.org](http://www.wbdg.org)

FOR PERVIOUS SURFACES SEE UTAH LOW IMPACT DEVELOPMENT GUIDE (REVISED: AUGUST 2020) DWQ-2019-000161 (SECTION PS-1 PAGE C-36)

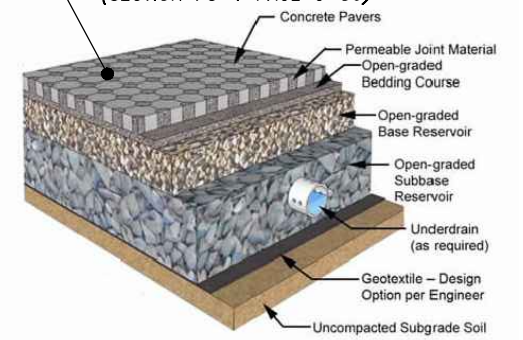

**PERMEABLE PAVER**  
 From Smith, D. 2006. *Permeable Interlocking Concrete Pavement—selection design, construction and maintenance. Third Edition.* Interlocking Concrete Pavement Institute. Herndon, VA



FOR RAIN BARREL SEE UTAH LOW IMPACT DEVELOPMENT GUIDE (REVISED: AUGUST 2020) DWQ-2019-000161 (SECTION HR-1 PAGE C-62)

**RAIN BARREL**  
<http://www.goodideasinc.com/products/rain-barrels/rain-wizard-50/>

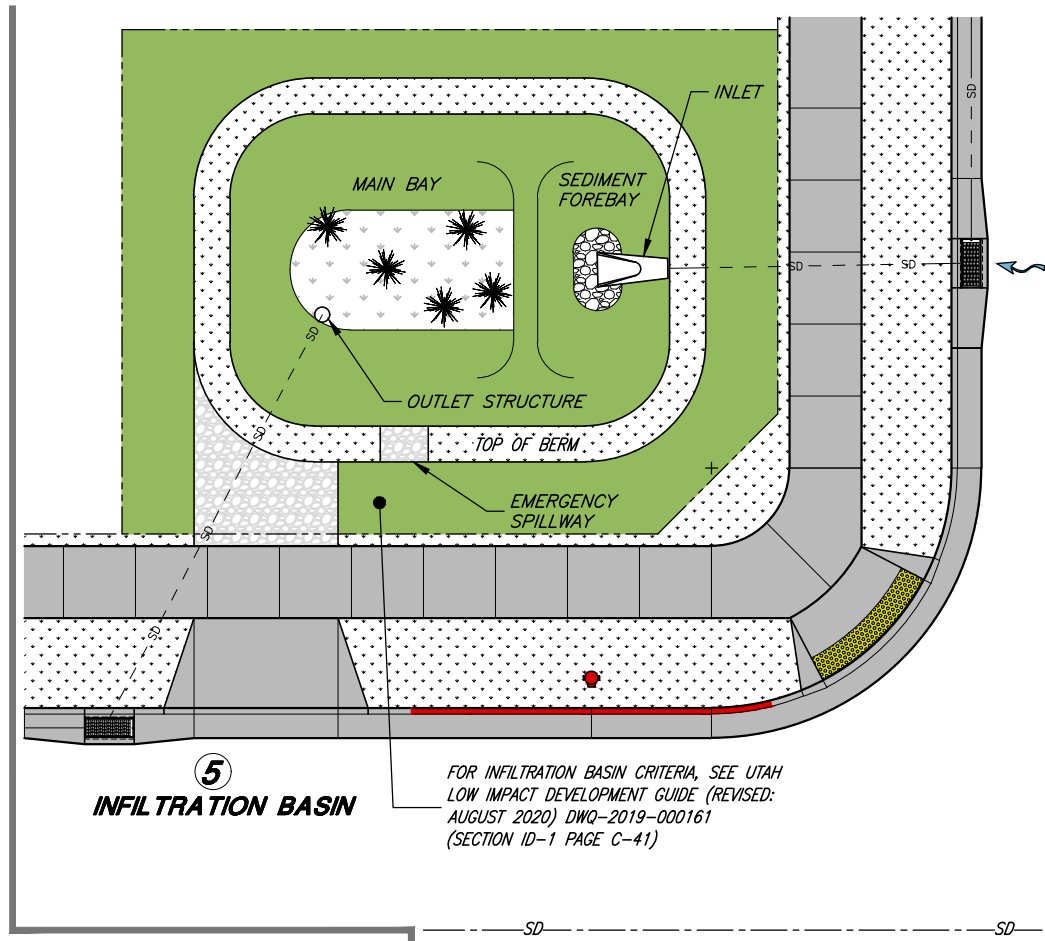

**5 INFILTRATION BASIN**

FOR INFILTRATION BASIN CRITERIA, SEE UTAH LOW IMPACT DEVELOPMENT GUIDE (REVISED: AUGUST 2020) DWQ-2019-000161 (SECTION ID-1 PAGE C-41)

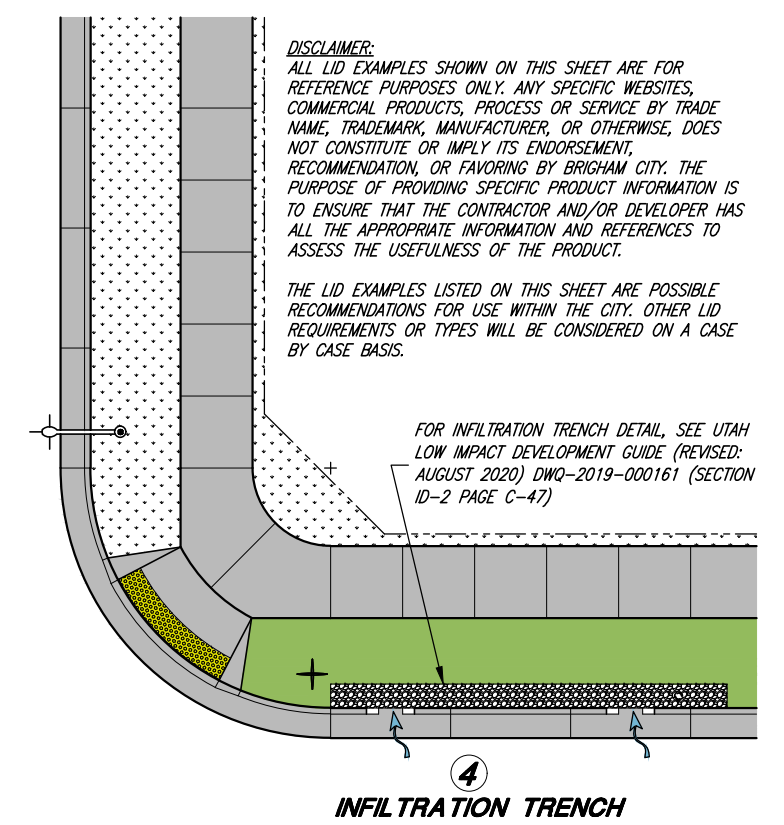

**4 INFILTRATION TRENCH**

**DISCLAIMER:**  
 ALL LID EXAMPLES SHOWN ON THIS SHEET ARE FOR REFERENCE PURPOSES ONLY. ANY SPECIFIC WEBSITES, COMMERCIAL PRODUCTS, PROCESS OR SERVICE BY TRADE NAME, TRADEMARK, MANUFACTURER, OR OTHERWISE, DOES NOT CONSTITUTE OR IMPLY ITS ENDORSEMENT, RECOMMENDATION, OR FAVORING BY BRIGHAM CITY. THE PURPOSE OF PROVIDING SPECIFIC PRODUCT INFORMATION IS TO ENSURE THAT THE CONTRACTOR AND/OR DEVELOPER HAS ALL THE APPROPRIATE INFORMATION AND REFERENCES TO ASSESS THE USEFULNESS OF THE PRODUCT.

THE LID EXAMPLES LISTED ON THIS SHEET ARE POSSIBLE RECOMMENDATIONS FOR USE WITHIN THE CITY. OTHER LID REQUIREMENTS OR TYPES WILL BE CONSIDERED ON A CASE BY CASE BASIS.

FOR INFILTRATION TRENCH DETAIL, SEE UTAH LOW IMPACT DEVELOPMENT GUIDE (REVISED: AUGUST 2020) DWQ-2019-000161 (SECTION ID-2 PAGE C-47)

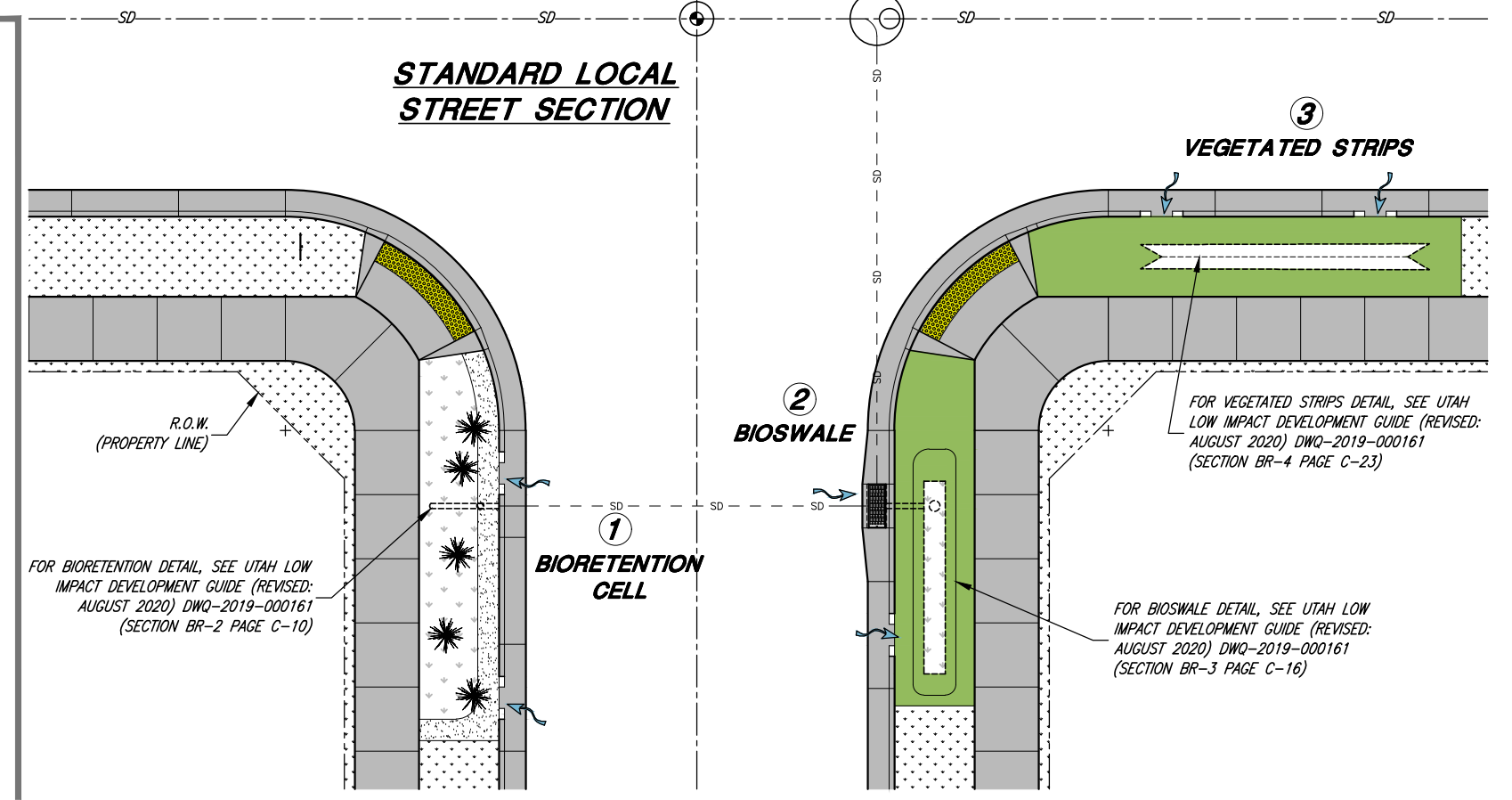

FOR BIORETENTION DETAIL, SEE UTAH LOW IMPACT DEVELOPMENT GUIDE (REVISED: AUGUST 2020) DWQ-2019-000161 (SECTION BR-2 PAGE C-10)

FOR VEGETATED STRIPS DETAIL, SEE UTAH LOW IMPACT DEVELOPMENT GUIDE (REVISED: AUGUST 2020) DWQ-2019-000161 (SECTION BR-4 PAGE C-23)

FOR BIOSWALE DETAIL, SEE UTAH LOW IMPACT DEVELOPMENT GUIDE (REVISED: AUGUST 2020) DWQ-2019-000161 (SECTION BR-3 PAGE C-16)



BRANDON KENT JONES  
 No. 5148758  
 PROJECT ENGINEER  
 11/28/2023  
 DATE

REV.	DATE	APPR.

SCALE:  
 N. T.S.  
 DESIGNED BKJ  
 DRAWN BEB  
 CHECKED BKJ



**CONSULTING ENGINEERS**  
 6080 Fashion Point Drive  
 South Ogden, Utah 84403 (801) 476-9767  
[www.jonescivil.com](http://www.jonescivil.com)

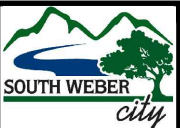

**SOUTH WEBER CITY CORPORATION**  
**PUBLIC WORKS - LID (LOW IMPACT DEVELOPMENT) STANDARDS**  
**GENERAL LID (LOW IMPACT DEVELOPMENT) EXAMPLES**

SHEET:  
**LID1**  
 OF 34 SHEETS  
 0

SUBDIVISION PLAT REQUIREMENTS		
	PRELIM. PLAT	FINAL PLAT
1 PLAT TO SHOW ALL PHASES & FUTURE DEVELOPMENT	X	X
2 VICINITY MAP (SUBD. LOCATION)	X	X
3 NAME OF THE SUBDIVISION	X	X
4 TRUE NORTH ARROW	X	X
5 DATE	X	X
6 PLAT LEGEND	X	X
7 SECTION, TOWNSHIP, RANGE	X	X
8 NAMES OF DEVELOPER(S)	X	X
9 SUBDIVISION BOUNDARY DESCRIPTION	X	X
10 ADJOINING LAND OWNER(S)	X	X
11 TOTAL ACREAGE OF DEVELOPMENT	X	X
12 SURVEY NARRATIVE	X	X
13 BASIS OF BEARINGS	X	X
14 TIES TO TWO SECTION CORNERS WITH BEARINGS & DISTANCES	X	X
SIGNATURE BLOCKS FOR:		
15 COUNTY RECORDER	X	X
16 OWNER DEDICATION	X	X
17 CITY PLANNER/LAND USE AUTHORITY	X	X
18 CITY ENGINEER	X	X
19 MAYOR	X	X
20 CITY RECORDER	X	X
21 CITY ATTORNEY	X	X
22 SURVEYOR'S CERTIFICATE	X	X
MEASUREMENTS & DIMENSIONS		
23 SCALE, GRAPHIC SCALE	X	X
24 LENGTHS	X	X
25 ANGLES & BEARINGS	X	X
CURVE DATA		
26 RADIUS, CENTRAL ANGLE, TANGENTS, ARC LENGTH	X	X
27 BEARING DIMENSIONS FOR ALL LOT LINES	X	X
28 SQ FT OF EACH LOT	X	X
29 SURVEY MONUMENTS	X	X
30 PUBLIC LANDS & STREETS IDENTIFIED	X	X
31 RIGHT-OF-WAY LINES	X	X
32 IDENTIFY SPECIFIC DEDICATIONS (ROADS, PARCEL NO., ETC.)	X	X
33 WIDTHS/LOCATIONS OF STREETS & PUBLIC PROPERTIES	X	X
34 STREET NAMES AND/OR COORDINATE NUMBERS	X	X
35 SHOW AND LABEL ALL EASEMENTS	X	X
36 NOTES & RESTRICTIONS	X	X
37 SHOW "R" ON ALL RESTRICTED LOTS	X	X
38 SPECIALIZED DEVELOPMENT STANDARDS	X	X
39 CCR'S WHERE APPLICABLE	X	X
40 SHOW SPECIAL UTILITIES AND DISTRICTS	X	X
41 OTHER RESTRICTIVE LANGUAGE, TERMS, RESTRICTIONS, CONDITIONS	X	X
42 EASEMENT APPROVAL (AS APPLICABLE)	X	X
43 NEW LOT ADDRESSES (ASSIGNED BY THE CITY)	X	X
44 DRINKING WATER SOURCE PROTECTION ZONES	X	X
45 FEMA FLOOD ZONES, FAULT, DEBRIS FLOW OR OTHER GEOLOGICAL HAZARD SETBACKS	X	X

SHEET 1 OF X

# 3 SUBDIVISION NAME

7 A PART OF SECTION X, TOWNSHIP X, RANGE X, S.L.B.&M. SOUTH WEBER CITY, DAVIS COUNTY, UTAH

## 9 SUBDIVISION BOUNDARY DESCRIPTION

BEING PART OF SECTION X, TOWNSHIP X, RANGE X OF THE SALT LAKE BASE AND MERIDIAN. BEGINNING AT A POINT ..... FROM THE X CORNER OF SAID SECTION X; RUNNING THENCE.....

5 DATE

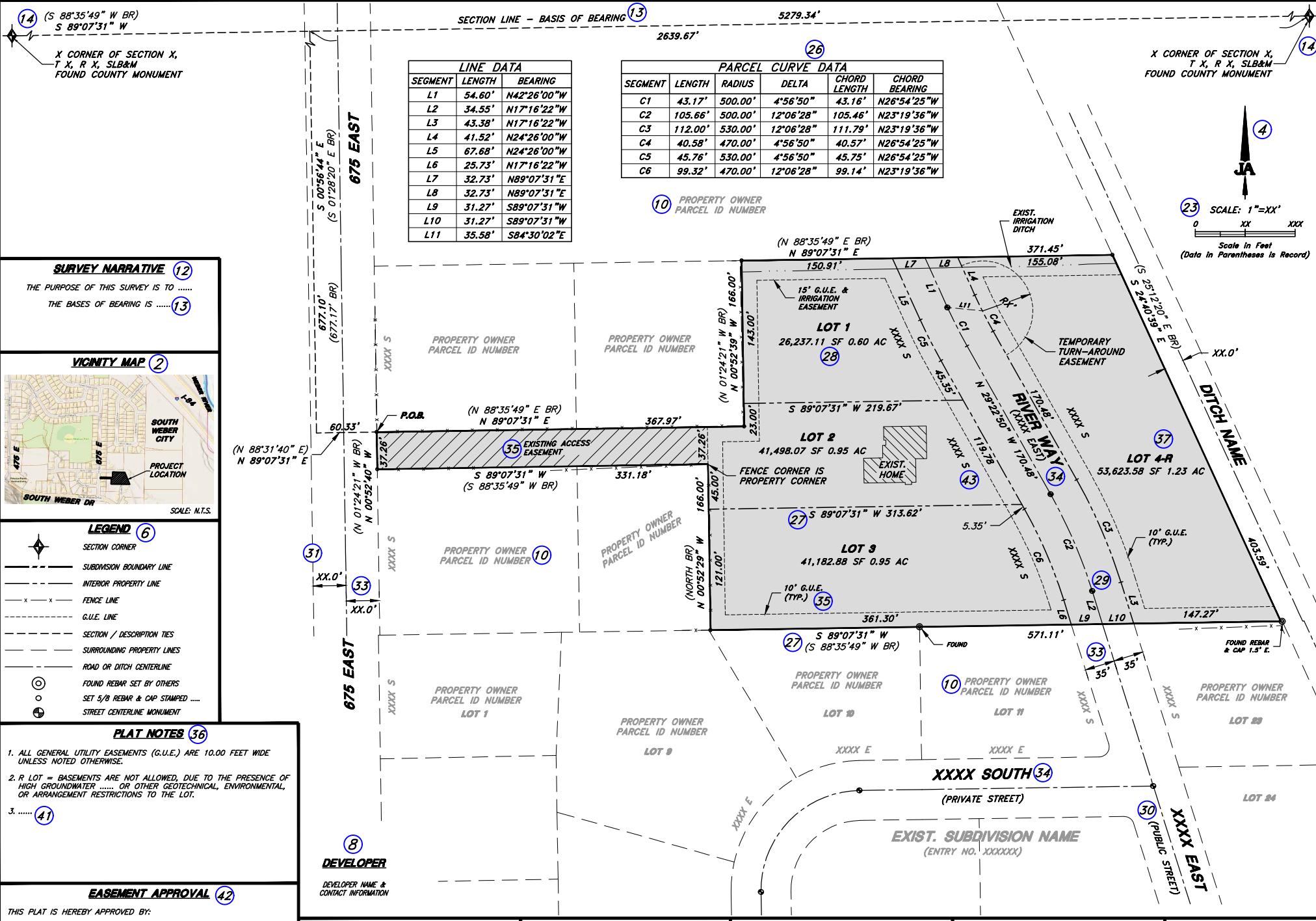

**12 SURVEY NARRATIVE**  
THE PURPOSE OF THIS SURVEY IS TO ..... THE BASES OF BEARING IS ..... 13

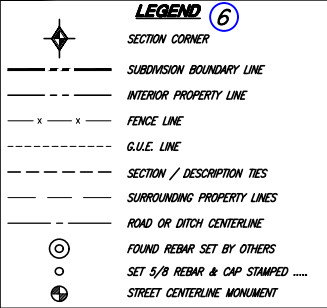
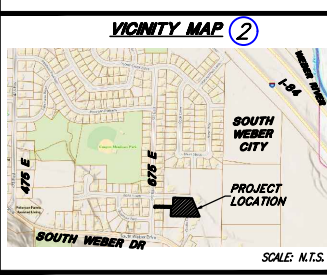

**36 PLAT NOTES**  
1. ALL GENERAL UTILITY EASEMENTS (G.U.E.) ARE 10.00 FEET WIDE UNLESS NOTED OTHERWISE.  
2. R LOT = BASEMENTS ARE NOT ALLOWED, DUE TO THE PRESENCE OF HIGH GROUNDWATER ..... OR OTHER GEOTECHNICAL, ENVIRONMENTAL, OR ARRANGEMENT RESTRICTIONS TO THE LOT.  
3. .... 41

**42 EASEMENT APPROVAL**  
THIS PLAT IS HEREBY APPROVED BY:  
RIVERDALE BENCH CANAL COMPANY DATE  
CENTRAL WEBER SEWER DISTRICT DATE  
WEBER BASIN WATER CONSERVANCY DISTRICT DATE  
PACIFICORP DATE

**17 SOUTH WEBER CITY PLANNING COMMISSION APPROVAL**  
APPROVED THIS \_\_\_\_\_ DAY OF \_\_\_\_\_, 20XX, BY THE SOUTH WEBER CITY PLANNING COMMISSION.  
CHAIRMAN

**21 SOUTH WEBER CITY ATTORNEY**  
APPROVED THIS \_\_\_\_\_ DAY OF \_\_\_\_\_, 20XX, BY THE SOUTH WEBER CITY ATTORNEY.  
CITY ATTORNEY

**19 SOUTH WEBER CITY COUNCIL APPROVAL AND ACCEPTANCE**  
PRESENTED TO THE SOUTH WEBER CITY COUNCIL THIS \_\_\_\_\_ DAY OF \_\_\_\_\_, 20XX, AT WHICH TIME THIS SUBDIVISION WAS APPROVED AND ACCEPTED.  
SOUTH WEBER CITY MAYOR  
20 ATTEST: CITY RECORDER

**18 SOUTH WEBER CITY ENGINEER**  
APPROVED THIS \_\_\_\_\_ DAY OF \_\_\_\_\_, 20XX, BY THE SOUTH WEBER CITY ENGINEER.  
SOUTH WEBER CITY ENGINEER

**PLAT SURVEYOR AND/OR ENGINEERING COMPANY CONTACT INFORMATION**

**15 DAVIS COUNTY RECORDER**  
STATE OF UTAH, COUNTY OF DAVIS, RECORDED AND FILED AT THE REQUEST OF \_\_\_\_\_ DATE \_\_\_\_\_ TIME \_\_\_\_\_ FEE \_\_\_\_\_ ENTRY \_\_\_\_\_ INDEX \_\_\_\_\_ FILED IN: \_\_\_\_\_ FILE OF PLATS COUNTY RECORDER CHIEF DEPUTY

**REGISTERED PROFESSIONAL ENGINEER**  
BRANDON KENT JONES  
No. 5148758  
11/28/2023  
DATE

SCALE:	DESIGNED: BKJ	
N. T.S.	DRAWN: BEB	
	CHECKED: BKJ	
REV.	DATE	APPR.

JA JONES & ASSOCIATES

**CONSULTING ENGINEERS**  
6080 Fashion Point Drive  
South Ogden, Utah 84403 (801) 476-9767  
www.jonescivil.com

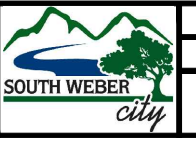

**SOUTH WEBER CITY CORPORATION**  
PUBLIC WORKS - MISCELLANEOUS DEVELOPMENT STANDARDS  
SUBDIVISION PRELIMINARY & FINAL PLAT SUBMITTALS EXAMPLE  
SHEET: DEV1 OF 34 SHEETS 0

