

PLANNING MEMORANDUM

1600 E. South Weber Drive
South Weber, UT 84405

www.southwebercity.com

801-479-3177
FAX 801-479-0066

To: Planning Commission
From: Trevor Cahoon, Community Services Director; Brandon Jones, City Engineer
Re: **RV General Commercial Development for RV Sales & Service**

Project Information	
Project Name	South Weber RV General
Site Location	Approx. 475 E 6650 S
Tax ID Number	130180090, 130230214
Applicant	Kevin Schonshenk
Owner	MacOgden Group LLC
Proposed Actions	Preliminary Plan/Final Subdivision Plat, Conditional Use Permit & Agreements
Current Zoning	CH
General Plan Land Use Classification	CH
Gross Site	16.430 Acres

ACTION

Administrative Action: Consider recommendation of approval of Petersen Farms Final Plat Amendment and Necessary Agreements.

ITEMS FOR PLANNING COMMISSION REVIEW

- **Final Plat.** Because the Developer is requesting a single lot subdivision, they have chosen to move forward with their subdivision as a Preliminary/Final submission. Final Plat Items to Consider:
 - *Legal Description:* This has been supplied
 - *Subdivision Name:* The Subdivision name appears on the plat and is consistent with the application that has been submitted.
 - *Lot Sizes and Orientation:* N/A.
 - *Parcel Numbers or Lot Numbers of Surrounding Properties:* When recording the plat it is necessary to indicate the parcel identification numbers or the lot number for adjoining subdivisions. This plat has that necessary information.
 - *Right-of-Way (ROW) Dedication:* The ROW has been indicated on the drawings for dedication to the City and the widths comply with the City Standards.
 - *Utility Easements:* The General Utility Easement required for each property has been indicated on the plat. Developer has supplied the necessary easement dedication for the Powerline Corridor and is consistent with widths required in other areas.
 - *Signature Boxes:* All signature boxes are supplied.

-
- **Site Plan:** The commercial use required the submission of a site plan to the Planning Commission for approval.
 - **Conditional Use Permit:** A conditional use is needed as the project is over an acre and the use is a conditional use.
 - **Architectural Review:** The projects require an architectural site plan review.
 - **Improvement Plans:** Developer has submitted improvement plans to be included in the submission.
 - **Maintenance Agreement:** With the inclusion of the landscaping along the public right-of-way and numerous public utilities that will be included in the project staff has drafted a maintenance agreement that will commit the property to maintain their improvements on their site.

APPROVALS PREVIOUSLY GRANTED BY PLANNING COMMISSION

N/A

RECOMMENDATIONS PREVIOUSLY GRANTED BY PLANNING COMMISSION

N/A

STAFF REVIEW SUMMARY

City Staff has done a review of General RV Development and have reviewed the following

items: **Planning Review:**

PL-1: Zoning

PL-1: The current zoning for this project is Commercial-Highway (C-H). The use is allowed within that zone as a conditional use and will need to be processed through the conditional use application.

PL-2: Project Size

PL-2: The Project totals 16.430. This is smaller than the original site.

PL-3: The developer is requesting to exclude the area that is designated as wetlands and will continue to work with the Army Corp of Engineers to include the rest of the area later in a subdivision amendment. This could have implications for the required fencing and may cause issues because it creates a parcel that cannot be accessed except through the property itself. As the developer continues to work with the Riverdale Canal Company and the Army Corp of Engineers they want to exclude this portion and the City can wave the requirement of the fence until such time a solution can be made, otherwise the City could require a temporary fence along the border.

PL-3: Lot Area

PL-4: There are no minimum lot area requirements.

PL-4: Lot Width

PL-5: No minimum width required.

PL-5: Setbacks

PL-6: Setback needs to be 50' from the front and 20' from the side that is fronting 475 E. The site plan provided shows this to not be an issue.

PL-6: Access

PL-7: A traffic study has been submitted and verified and shows no concerning numbers for the affected traffic impact.

PL-7: Roads

PL-8: Developer will not be adding roads to the project area. There will be a need for striping along Old Fort Road and 475 E.

PL-9: Developer is responsible to install a trail connection for the area as shown in the General Plan. Working with the developer the City has requested that the sidewalk in the Public ROW be widened to accommodate both a trail connection and the sidewalk for the ROW.

PL-8: Landscaping

PL-10: At least fifteen percent (15%) of the total site shall be thoroughly landscaped, including an irrigation system to maintain such landscaping. For use of exceptional design and materials, as determined by the Planning Commission, the landscaping may be reduced to ten percent (10%) of the total site.

- a. The developer has committed to improving the landscape along Old Fort Road and the trail/sidewalk and are requesting the 10% consideration for this effort.

PL-11: Buffer Yard is not necessary as the site does not abut residential.

PL-9: Architectural Review

PL-12: Developer has submitted renderings of the buildings.

PL-10: Fencing

PL-13: South Weber City Code indicates that a masonry wall is needed along the I-84 corridor. This requirement can be waived based upon recommendation from the Planning Commission and approval by the City Council if they determine that the purpose of the fence (protection from wildfire and automobile accidents) is not necessary for the development. Upon review by the South Weber Fire Chief, Derek Tolman, staff feels that this site has other mitigating factors such as large asphalted areas that will accomplish the same purpose.

PL-11: Site Plan

PL-14: Parking: There is sufficient parking for the project. There will be a total number of customer dedicated parking of 144 Stalls.

PL-15: Internally the site will have the RV's behind fencing with internal flow adequate for general traffic. The main entrance and exit appears to be on 475 E with the drive on Old Fort Road being an exit gate only.

WEBER PROPERTIES SUBDIVISION
 LOCATED IN THE NORTHWEST QUARTER OF SECTION 28, THE NORTHEAST QUARTER OF SECTION 29 THE
 SOUTHEAST QUARTER OF SECTION 20, AND THE SOUTHWEST QUARTER OF SECTION 21,
 TOWNSHIP 5 NORTH, RANGE 1 WEST, SALT LAKE BASE AND MERIDIAN,
 SOUTH WEBER CITY, DAVIS COUNTY, UTAH
 DECEMBER 2022

BOUNDARY DESCRIPTION

A PART OF THE NORTHWEST QUARTER OF SECTION 28, THE NORTHEAST QUARTER OF SECTION 29, THE SOUTHEAST QUARTER OF SECTION 20 AND THE SOUTHWEST QUARTER OF SECTION 21, TOWNSHIP 5 NORTH, RANGE 1 WEST OF THE SALT LAKE BASE AND MERIDIAN, MORE PARTICULARLY DESCRIBED AS FOLLOWS:

BEGINNING AT A POINT ON THE NORTH LINE OF THE NORTHEAST QUARTER OF SAID SECTION 29, BEING LOCATED NORTH 89°07'40" WEST 108.08 FEET (BASIS OF BEARING BEING THE NORTH LINE OF THE NORTHEAST QUARTER OF SAID SECTION 29 WHICH BEARS NORTH 89°07'40" WEST NAD 83 STATE PLANE GRID BEARING) FROM THE NORTHEAST QUARTER OF SAID SECTION, SAID POINT BEING ON THE EAST RIGHT-OF-WAY LINE OF 475 EAST; RUNNING THENCE ALONG SAID RIGHT-OF-WAY LINE NORTH 00°29'39" EAST 31.52 FEET; THENCE CONTINUING ALONG SAID RIGHT-OF-WAY LINE NORTH 10°30'37" EAST 530.44 FEET TO A POINT ON THE SOUTH BANK LINE OF AN EXISTING IRRIGATION CANAL; THENCE ALONG SAID SOUTH BANK LINE THE FOLLOWING NINE (9) COURSES: (1) SOUTH 69°33'50" EAST 82.55 FEET; (2) SOUTH 69°03'50" EAST 288.35 FEET; (3) SOUTH 60°56'57" EAST 140.82 FEET; (4) SOUTH 61°43'06" EAST 109.67 FEET; (5) SOUTH 63°29'12" EAST 85.50 FEET; (6) SOUTH 50°08'13" EAST 214.95 FEET; (7) SOUTH 43°25'35" EAST 132.01 FEET; (8) SOUTH 85°24'35" EAST 237.28 FEET; (9) SOUTH 38°14'17" EAST 63.46 FEET; THENCE SOUTH 82°57'31" WEST 155.25 FEET; THENCE SOUTH 07°07'49" EAST 198.86 FEET; THENCE SOUTH 50°41'10" EAST 22.70 FEET; THENCE SOUTH 07°02'29" EAST 114.17 FEET TO THE RIGHT-OF-WAY LINE OF OLD FORT ROAD; THENCE ALONG SAID RIGHT-OF-WAY THE FOLLOWING THREE (3) COURSES: (1) NORTH 85°35'49" WEST 889.13 FEET; (2) ALONG THE ARC OF A CURVE TO THE RIGHT 466.96 FEET, HAVING A RADIUS OF 311.00 FEET, A CENTRAL ANGLE OF 86°01'41", AND WHICH CHORD BEARS NORTH 42°34'59" WEST 424.31 FEET; (3) NORTH 02°29'39" EAST 3.15 FEET TO THE POINT OF BEGINNING, CONTAINING 16.430 ACRES.

SURVEYOR'S CERTIFICATE

I, KLINT H. WHITNEY, DO HEREBY CERTIFY THAT I AM A LICENSED PROFESSIONAL LAND SURVEYOR IN THE STATE OF UTAH AND THAT I HOLD CERTIFICATE NO. 8227228 IN ACCORDANCE WITH TITLE 58, CHAPTER 22, OF THE PROFESSIONAL ENGINEERS AND LAND SURVEYORS ACT. I FURTHER CERTIFY THAT BY AUTHORITY OF THE OWNERS I HAVE COMPLETED A SURVEY OF THE PROPERTY AS SHOWN AND DESCRIBED ON THIS PLAN, AND HAVE SUBDIVIDED SAID PROPERTY INTO LOTS AND STREETS, TOGETHER WITH EASEMENTS, HEREAFTER TO BE KNOWN AS WEBER PROPERTIES SUBDIVISION IN ACCORDANCE WITH SECTION 17-23-17 AND HAVE VERIFIED ALL MEASUREMENTS; THAT THE REFERENCE MONUMENTS SHOWN HEREON ARE LOCATED AS INDICATED AND ARE SUFFICIENT TO RETRACE OR REESTABLISH THIS SURVEY; THAT ALL LOTS MEET THE REQUIREMENTS OF THE LAND USE CODE; AND THAT THE INFORMATION SHOWN HEREIN IS SUFFICIENT TO ACCURATELY ESTABLISH THE LATERAL BOUNDARIES OF THE HEREIN DESCRIBED TRACT OF REAL PROPERTY.

SIGNED THIS _____ DAY OF _____, 2023.

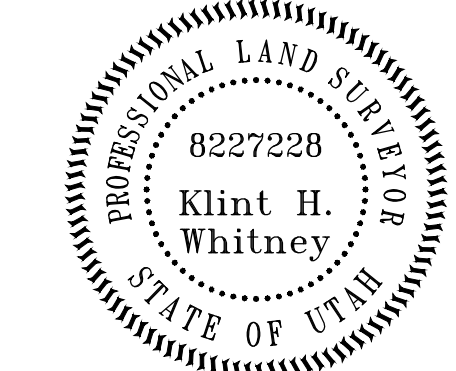

KLINT H. WHITNEY, PLS NO. 8227228

OWNER'S DEDICATION

I THE UNDERSIGNED OWNER OF THE HEREON DESCRIBED TRACT OF LAND, HEREBY SET APART AND SUBDIVIDE THE SAME INTO LOTS, PARCELS AND STREETS AS SHOWN ON THIS PLAN AND NAME SAID TRACT:

WEBER PROPERTIES SUBDIVISION

AND HEREBY DEDICATE, GRANT AND CONVEY TO SOUTH WEBER CITY, DAVIS COUNTY, UTAH, ALL THOSE PARTS OR PORTIONS OF SAID TRACT OF LAND DESIGNATED AS STREETS, THE SAME TO BE USED AS PUBLIC THOROUGHFARES FOREVER, AND ALSO GRANT AND DEDICATE A PERPETUAL EASEMENT OVER, UPON AND UNDER THE LANDS DESIGNATED ON THE PLAN AS PUBLIC UTILITY AND DRAINAGE EASEMENT (P.U.E.), THE SAME TO BE USED FOR THE INSTALLATION, MAINTENANCE AND OPERATION OF PUBLIC UTILITY SERVICE LINES, STORM DRAINAGE FACILITIES OR FOR THE PERPETUAL PRESERVATION OF WATER DRAINAGE CHANNELS IN THEIR NATURAL STATE WHICHEVER IS APPLICABLE AS MAY BE AUTHORIZED BY SOUTH WEBER CITY, UTAH, WITH NO BUILDINGS OR STRUCTURES BEING ERRECTED WITHIN SUCH EASEMENTS.

SIGNED THIS _____ DAY OF _____, 2023.

BY: CARTER RANDALL

BY: NATHAN HARBERTSON

BY: DANIEL MCENTEE

ACKNOWLEDGEMENT

STATE OF UTAH)
)
 COUNTY OF DAVIS)

On this _____ day of _____, 2023, personally appeared before me CARTER RANDALL, whose identity is personally known to me (or proven on the basis of satisfactory evidence) and who by me duly sworn/affirmed, did say that he/she is the _____ of MACGOSDEN GROUP LLC, and that said document was signed by him/her in behalf of said "Corporation by Authority of its Bylaws, or (Resolution of its Board of Directors), and said acknowledged to me that said "Corporation executed the same.

STAMP _____ NOTARY PUBLIC

NARRATIVE

THE PURPOSE OF THIS SURVEY WAS TO CREATE A ONE LOT SUBDIVISION ON THE PROPERTY AS SHOWN AND DESCRIBED HEREON. THE CONTROL USED TO ESTABLISH THE BOUNDARY WAS THE EXISTING DAVIS COUNTY SURVEY MONUMENTATION AS SHOWN HEREON. THE BASIS OF BEARING IS THE SOUTH LINE OF THE SOUTHEAST QUARTER OF SECTION 20, TOWNSHIP 5 NORTH, RANGE 1 WEST, OF THE SALT LAKE BASE AND MERIDIAN WHICH BEARS NORTH 89°07'40" WEST DAVIS COUNTY, UTAH NORTH, NAD 83 STATE PLANE GRID BEARING.

DAVIS COUNTY RECORDER

BOOK NUMBER _____
 PAGE NUMBER _____
 ENTRY NUMBER _____
 TIME RECORDED _____
 DATE RECORDED _____
 FEE PAID _____

 DAVIS COUNTY RECORDER
 BY: _____
 DEPUTY RECORDER

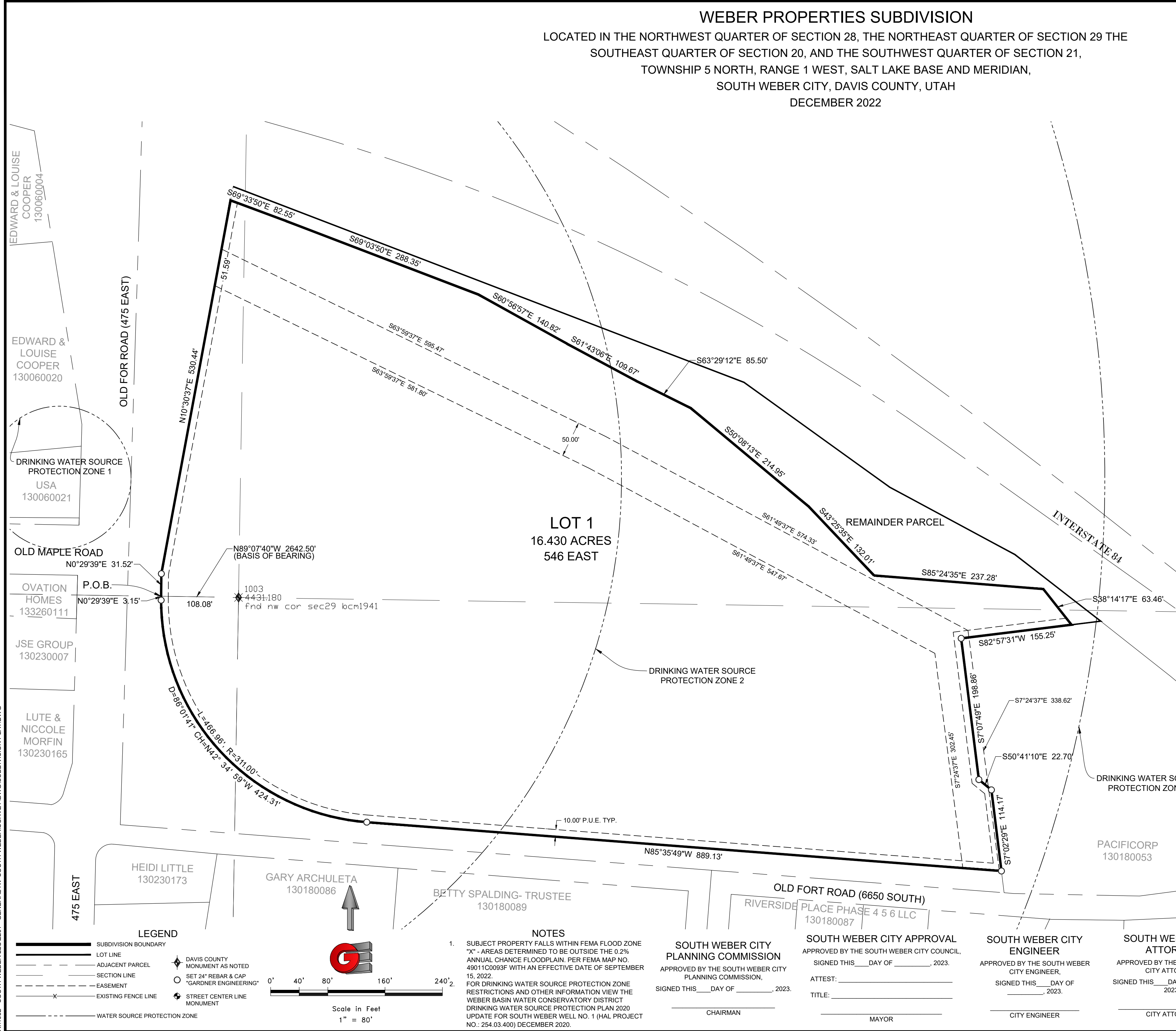

LEGEND

- SUBDIVISION BOUNDARY
- LOT LINE
- ADJACENT PARCEL
- SECTION LINE
- EASEMENT
- EXISTING FENCE LINE
- WATER SOURCE PROTECTION ZONE
- ◆ DAVIS COUNTY MONUMENT AS NOTED
- SET 24" REBAR & CAP "GARDNER ENGINEERING"
- ◆ STREET CENTER LINE MONUMENT

Scale in Feet
 1" = 80'

NOTES

- SUBJECT PROPERTY FALLS WITHIN FEMA FLOOD ZONE "X" - AREAS DETERMINED TO BE OUTSIDE THE 0.2% ANNUAL CHANCE FLOODPLAIN, PER FEMA MAP NO. 490110093F WITH AN EFFECTIVE DATE OF SEPTEMBER 15, 2022.

FOR DRINKING WATER SOURCE PROTECTION ZONE RESTRICTIONS AND OTHER INFORMATION VIEW THE WEBER BASIN WATER CONSERVATORY DISTRICT DRINKING WATER SOURCE PROTECTION PLAN 2020 UPDATE FOR SOUTH WEBER WELL NO. 1 (HAL PROJECT NO. 254.03.400) DECEMBER 2020.

SOUTH WEBER CITY PLANNING COMMISSION
 APPROVED BY THE SOUTH WEBER CITY PLANNING COMMISSION.
 SIGNED THIS _____ DAY OF _____, 2023.

CHAIRMAN _____ MAYOR _____

SOUTH WEBER CITY ENGINEER
 APPROVED BY THE SOUTH WEBER CITY ENGINEER.
 SIGNED THIS _____ DAY OF _____, 2023.

CITY ENGINEER _____

SOUTH WEBER CITY ATTORNEY
 APPROVED BY THE SOUTH WEBER CITY ATTORNEY.
 SIGNED THIS _____ DAY OF _____, 2023.

CITY ATTORNEY _____

R:\1952 - SOUTH WEBER LLC\2021 - GENERAL RV SOUTH WEBER SURVEY\DWG\SUBDIVISION PLAT.DWG

COLOR #1 - BRIGHT RED - METAL PANEL

COLOR #2 - BONE WHITE - METAL PANEL

COLOR #3 - BROWNSTONE - METAL PANEL

COLOR #4 - BRICK VENEER

COLOR #5 - PRE CAST CONCRETE PANEL

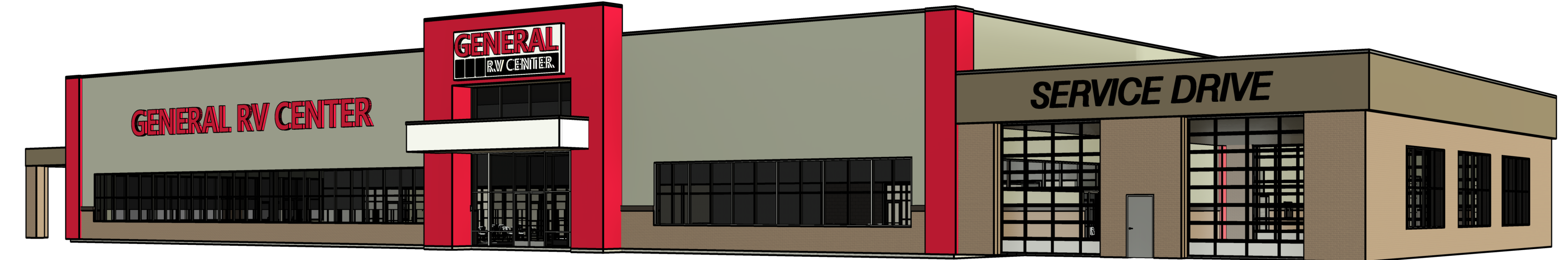

D1 RENDERING LEFT SIDE
 12" = 1'-0"

D2 RENDERING RIGHT SIDE
 12" = 1'-0"

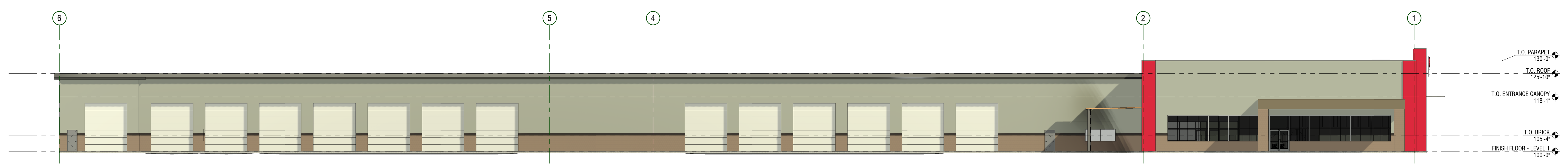

C1 LEFT ELEVATION
 1/16" = 1'-0"

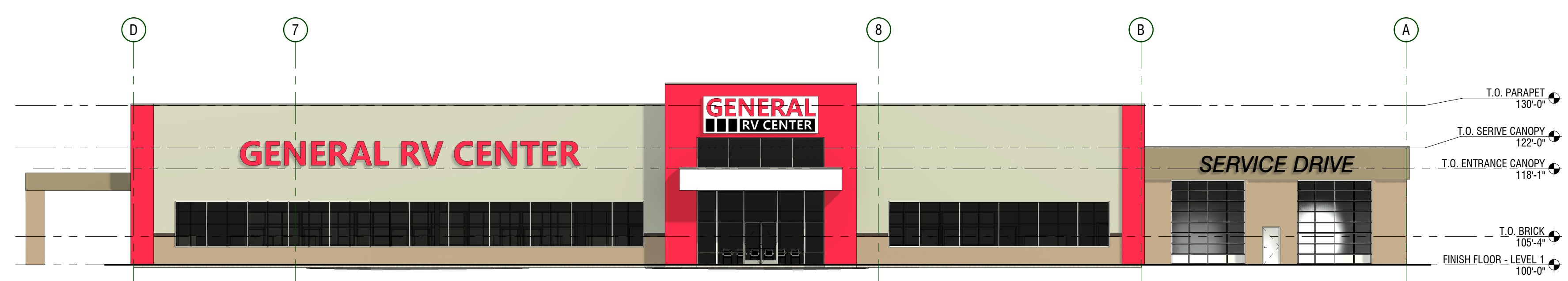

B1 FRONT ELEVATION
 1/16" = 1'-0"

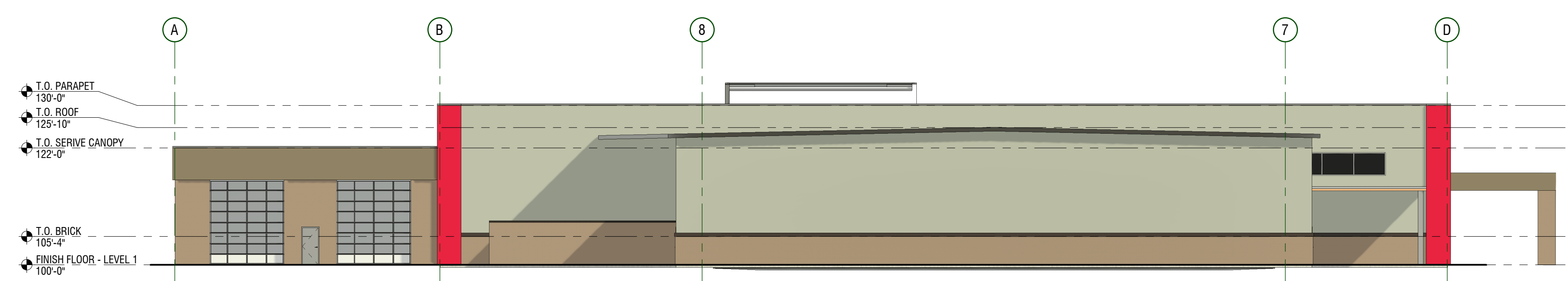

B4 REAR ELEVATION
 1/16" = 1'-0"

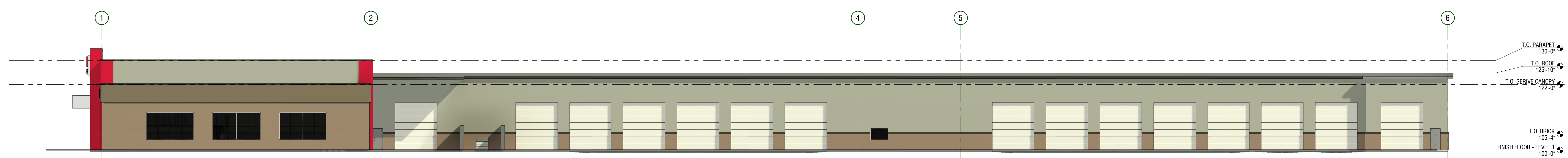

A1 RIGHT ELEVATION
 1/16" = 1'-0"

NOT FOR CONSTRUCTION

MARK	DATE	DESCRIPTION

PROJECT #:	422017
DRAWN BY:	FRANKS
CHECKED BY:	WILLIAMS
ISSUED:	10.05.2022

THESE RECORD DRAWINGS HAVE BEEN BASED ON INFORMATION PROVIDED BY THE GENERAL CONTRACTOR AND OTHERS. THE ARCHITECT AND ENGINEERS HAVE NOT VERIFIED THE ACCURACY AND/OR COMPLETENESS OF THIS INFORMATION AND SHALL NOT BE RESPONSIBLE FOR ANY ERRORS OR OMISSIONS WHICH MAY BE INCORPORATED HEREIN AS A RESULT.

E
D
C
B
A

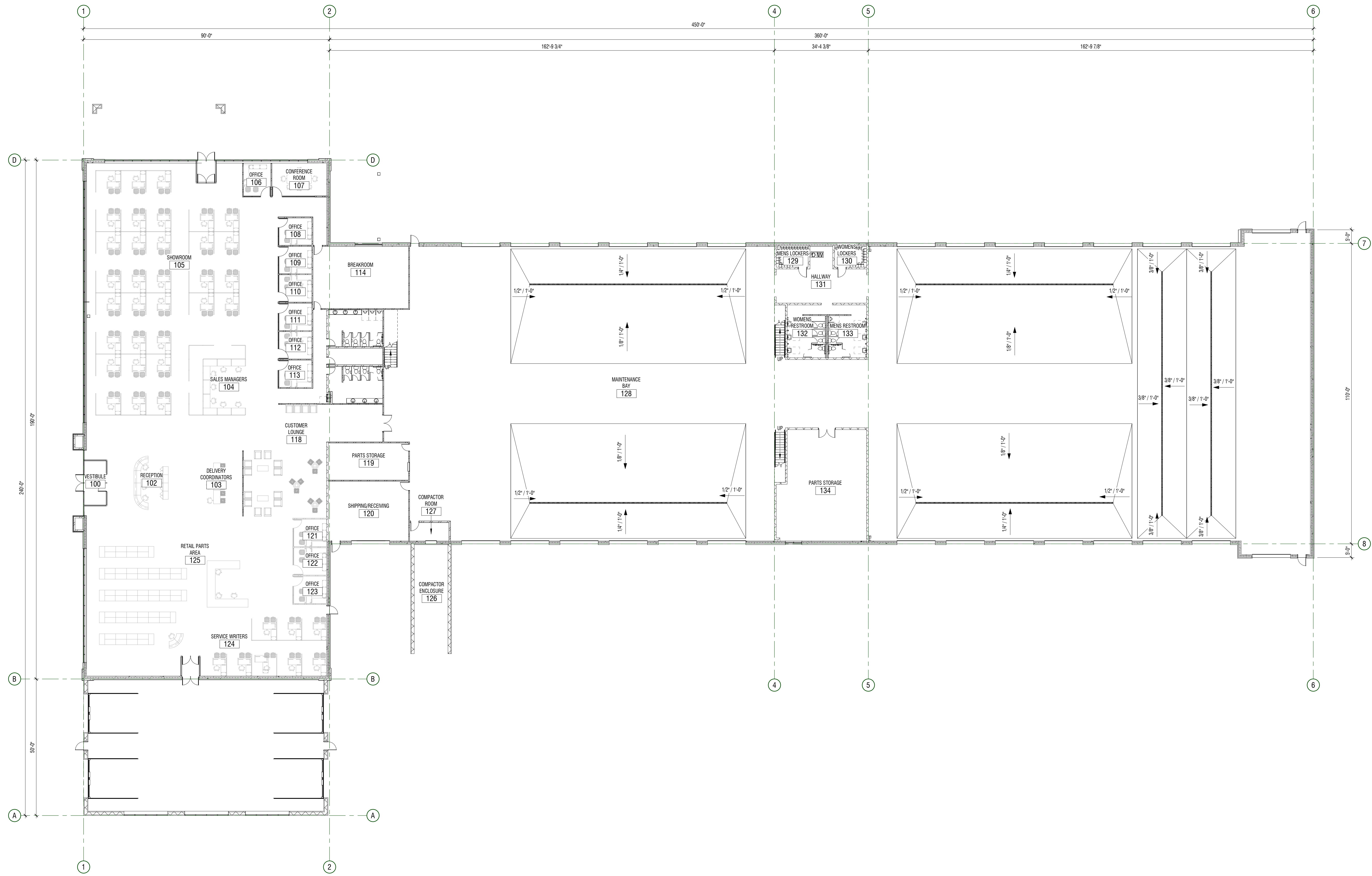

A1 OVERALL FLOOR PLAN
1/16" = 1'-0"

NOT FOR CONSTRUCTION

MARK	DATE	DESCRIPTION

PROJECT #:	422017
DRAWN BY:	FRANKS
CHECKED BY:	WILLIAMS
ISSUED:	10.05.2022

THESE RECORD DRAWINGS HAVE BEEN BASED ON INFORMATION PROVIDED BY THE GENERAL CONTRACTOR AND OTHERS. THE ARCHITECT AND ENGINEERS HAVE NOT VERIFIED THE ACCURACY AND/OR COMPLETENESS OF THIS INFORMATION AND SHALL NOT BE RESPONSIBLE FOR ANY ERRORS OR OMISSIONS WHICH MAY BE INCORPORATED HEREIN AS A RESULT.

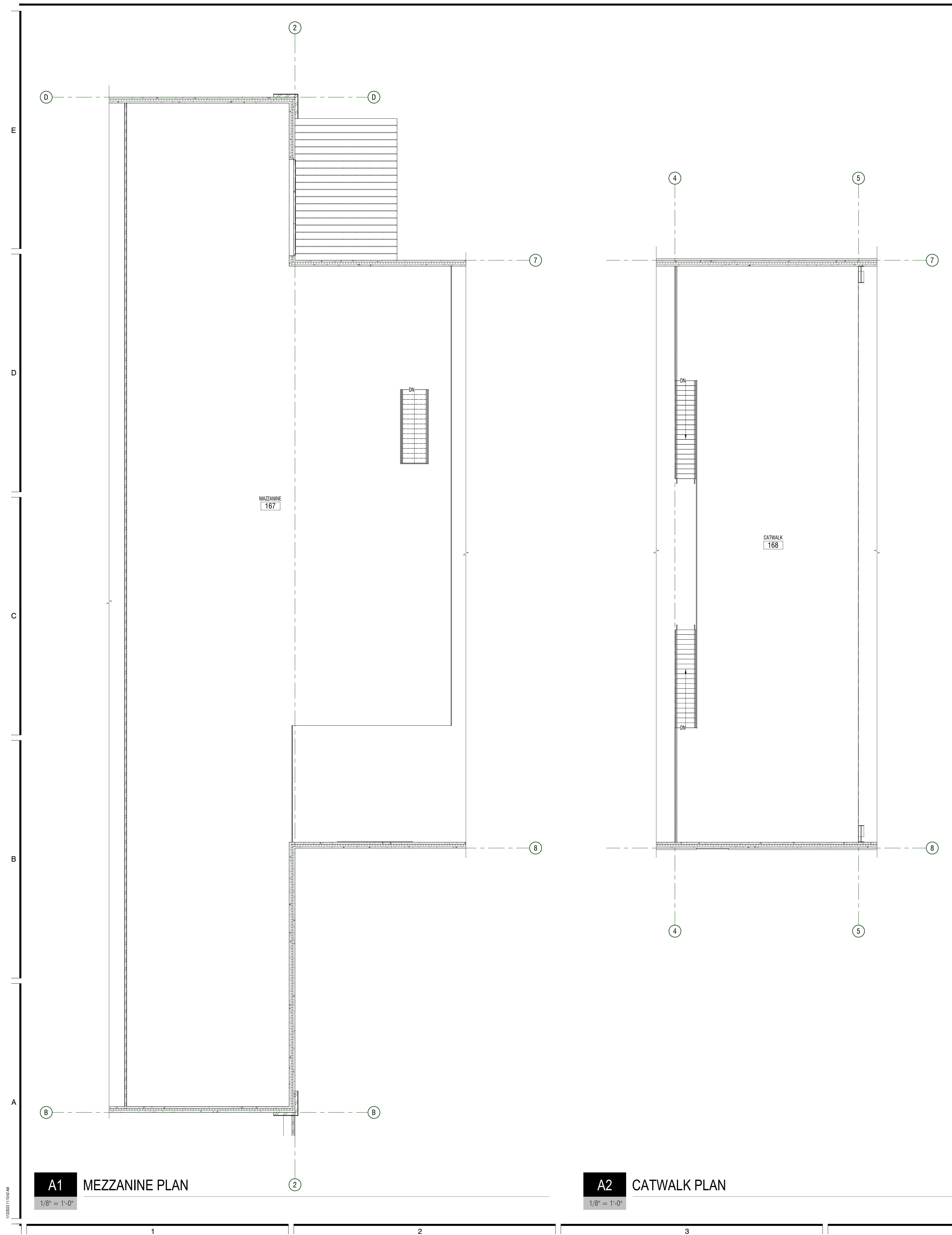

KEY PLAN

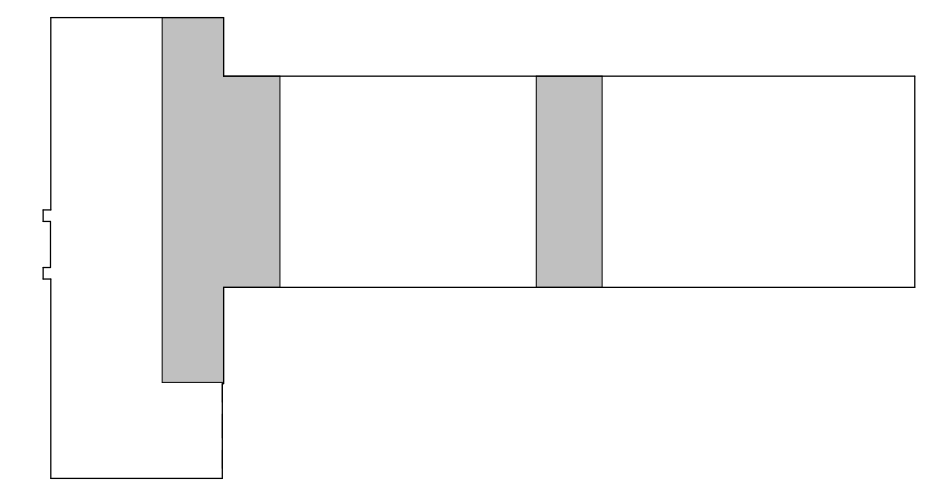

NOT FOR CONSTRUCTION

MARK	DATE	DESCRIPTION

PROJECT #:	422017
DRAWN BY:	FRANKS
CHECKED BY:	WILLIAMS
ISSUED:	10.05.2022

THESE RECORD DRAWINGS HAVE BEEN BASED ON INFORMATION PROVIDED BY THE GENERAL CONTRACTOR AND OTHERS. THE ARCHITECT AND ENGINEERS HAVE NOT VERIFIED THE ACCURACY AND/OR COMPLETENESS OF THIS INFORMATION AND SHALL NOT BE RESPONSIBLE FOR ANY ERRORS OR OMISSIONS WHICH MAY BE INCORPORATED HEREIN AS A RESULT.

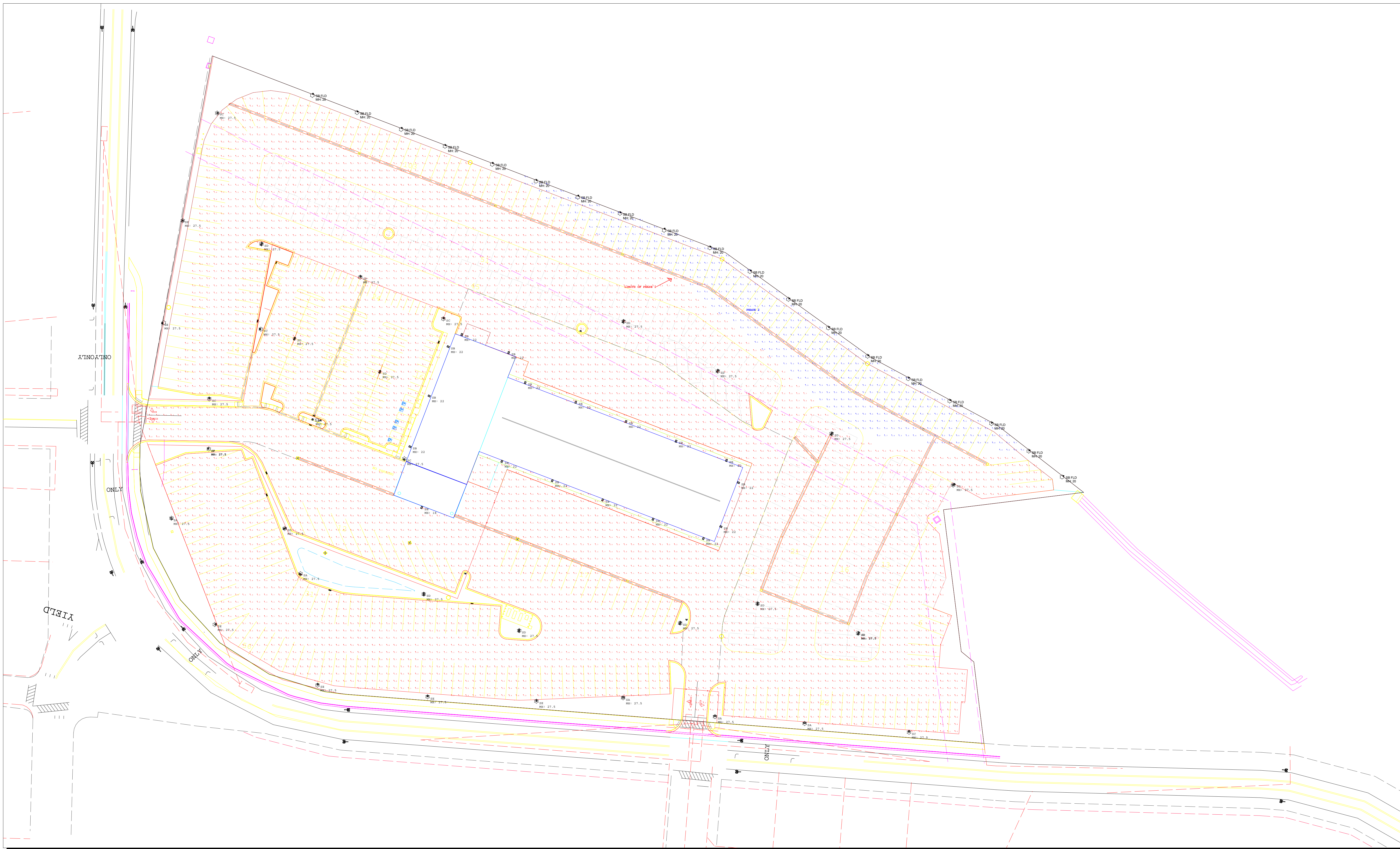

Scale: 1 inch= 60 Ft.

Luminaire Schedule							
Symbol	Qty	Label	LLF	Description	Lum. Watts	Lum. Lumens	Tag
□	5	GALN-SA6C0.920		GALN-SA6C-740-U-SL4-HSS	321	34293	SA
□	18	GALN-SA4C0.920		GALN-SA4C-740-U-T4FT	213	27751	SB
□	13	GALN-SA4C0.920		GALN-SA4C-740-U-5WQ	213	29108	SD
□	6	GALN-SA4C0.920		GALN-SA4C-740-U-T4FT	213	27751	SC
□	7	GALN-SA4C0.920		GALN-SA4C-740-U-T2R	213	28344	SE
□	2	GALN-SA4C0.920		GALN-SA4C-740-U-5WQ	213	29108	SF
□	19	GFLD-SA4D0.920		GFLD-SA4D-940-U-WAF-XX	217	19888	SB FLD

Calculation Summary						
Label	Units	Avg	Max	Min	Max/Min	Avg/Min
PHASE 1 - PARKING	Fc	2.37	13.4	0.2	67.00	11.85
PHASE 2 - PARKING	Fc	1.79	4.2	0.1	42.00	17.90

01.11.23
01.12.13

VERSION
JW-REV2
JW-REV3

30775 Barrington St.
Madison Heights, MI 48071
P: 248.677.0850
F: 248.677.0512
E: info@clarus-lighting.com



SITE PHOTOMETRICS

GENERAL RV
SOUTH WEBER UTAH

DATE
01/11/2023
PROJECT No.
CLC23-101306
SHEET No.

L201

MARK	DATE	DESCRIPTION

PROJECT #: 422017
 DRAWN BY: J. CLEMENTS
 CHECKED BY: B. WRIGHT
 ISSUED: 1.18.2023

PLANT SCHEDULE

SYMBOL	CODE	QTY	BOTANICAL / COMMON NAME	CONT.
	AC	26	Acer platanoides 'Columnare' / Columnar Norway Maple	B & B 2"
	GL	6	Gleditsia triacanthos inermis 'Skyline' / Skyline Honey Locust	B & B 2"
	MS	8	Malus x 'Spring Snow' / Spring Snow Crab Apple	B & B 2"
	PP	14	Picea pungens glauca 'Bakeri' / Colorado Blue Spruce	B & B 6' Height
	ZS	15	Zelkova serata 'Village Green' / Village Green Zelkova	B & B 2"
	CH	59	Chamaebatia millefolium / Fernbush	5 gal
	JB	56	Juniperus horizontalis 'Broadmoor' / Broadmoor Juniper	5 gal
	MA	45	Mahonia aquifolium 'Compacta' / Compact Oregon Grape	5 gal
	PH	49	Physocarpus opulifolius 'UMNHarpell' / Fireside® Ninebark	5 gal
	RC	26	Rhamnus frangula 'Columnaris' / Alder Buckthorn	5 gal
	RT	60	Rhus trilobata 'Autumn Amber' / Autumn Amber Sumac	5 gal
	SPI	37	Spiraea betulifolia 'Tor' / White Frost™ Birchleaf Spirea	5 gal
	VB	26	Viburnum dentatum 'Blue Muffin' / Southern Arrowwood	5 gal
	PV	52	Panicum virgatum 'Shenandoah' / Switch Grass	2 gal
	SC	114	Schizachyrium scoparium 'Blazer' / Blaze Little Buestem	2 gal
	HH	47	Hemerocallis x 'Happy Returns' / Happy Returns Daylily	1 gal
	LA	53	Lavandula angustifolia 'Hidcote Superior' / Hidcote Superior Lavender	1 gal

REFERENCE NOTE SCHEDULE

SYMBOL	DESCRIPTION	QTY
	6"x6" CONCRETE MOWSTRIP	
	6" BLACK VINYL COATED CHAIN LINK - see civil	
	6" CHAINLINK FENCE - see civil	
	4" SWING GATE - see civil	
	20' ACCESS GATE - see civil	
	6" BOLLARDS - see civil	
	DETENTION BASIN - see civil	
	RELOCATED SIGN THIS LOCATION	
	RELOCATED MONUMENT SIGN	
	TRANSFORMER - see civil	
	FIRE HYDRANT - see civil	
	PROPANE TANK AREA - see civil	
	EXISTING CATCH BASIN	
	EXISTING LIGHT POLE	
	EXISTING STREET LIGHT BOX	
	EXISTING MANHOLE	
	EXISTING POWER POLE	
	BOULDER - 1'-2' DIAMETER	82
	BOULDER - 2'-3' DIAMETER	27
	2" MINUS CRUSHED ROCK - 3" depth, color to be chosen by owner, weed barrier beneath	79,826 sf
	COBBLE - washed, 4-inch size, color to be chosen by owner, weed barrier beneath	37,482 sf
	2" MINUS CRUSHED ROCK - coordinate with Rocky Mountain Power to supply crushed rock that matches the color and depth of rock shown on site, weed barrier beneath	2,888 sf

PLANTING NOTES

- CONTRACTOR TO VERIFY ALL CONDITIONS PERTAINING TO THIS PLAN AND REPORT ANY DISCREPANCIES IMMEDIATELY TO THE LANDSCAPE ARCHITECT.
- THE CONTRACTOR SHALL LOCATE AND VERIFY ALL UTILITIES LINES PRIOR TO PLANTING AND SHALL REPORT ANY CONFLICTS TO THE LANDSCAPE ARCHITECT.
- CONTRACTOR SHALL REPAIR ALL DAMAGES CAUSED BY OPERATIONS (WHICH OCCUR ON OR OFF SITE) TO THE ARCHITECT'S AND OWNER'S SATISFACTION.
- ALL QUANTITIES SHOWN ARE APPROXIMATE AND ARE FURNISHED SOLELY FOR THE CONTRACTOR'S CONVENIENCE. THEY DO NOT NECESSARILY CORRESPOND TO BID SCHEDULE ITEMS. IN THE CASE OF ANY DISCREPANCIES, PLANS SHALL OVERRIDE THE LANDSCAPE AND BID SCHEDULE QUANTITIES. CONTRACTOR SHALL VERIFY QUANTITIES SHOWN ON THE PLANS AND BASE THEIR BID ACCORDINGLY.
- DO NOT MAKE UNAPPROVED SUBSTITUTIONS. IF SPECIFIED LANDSCAPE MATERIAL IS NOT OBTAINABLE, SUBMIT PROOF OF NON-AVAILABILITY FROM AT LEAST FIVE SOURCES TO LANDSCAPE ARCHITECT, TOGETHER WITH PROPOSAL FOR USE OF EQUIVALENT MATERIAL FOR FINAL APPROVAL.
- LAYOUT INDIVIDUAL TREE AND PLANT LOCATIONS AND AREAS FOR MULTIPLE PLANTINGS, STAKE LOCATIONS, AND OUTLINE AREAS AND SECURE ARCHITECT'S ACCEPTANCE BEFORE START OF PLANTING WORK. MAKE MINOR ADJUSTMENTS AS MAY BE DIRECTED.
- INSTALL DEWITT PRO-5 WEED BARRIER UNDER MULCH. FABRIC SHALL BE INSTALLED AFTER PRE-EMERGENT HAS BEEN APPLIED. CUT AN "X" SHAPE IN WEED BARRIER FOR PLANTS AND STAPLE FOLDS DOWN INTO SOIL. USE FABRIC STAPLES EVERY FIVE FEET ON CENTER IN PLANTER BED.
- REPAIR ALL LANDSCAPING WHERE NEW CONSTRUCTION MEETS EXISTING.
- PERFORM PERCOLATION TEST ON ALL TREE PLANTING HOLES AND PLANTING BEDS PRIOR TO PLANTING. INFORM LANDSCAPE ARCHITECT OF CONDITIONS OF POOR DRAINAGE.
- LANDSCAPE CONTRACTOR SHALL COORDINATE AND ADJUST PLANT PLACEMENT WITH SPRINKLER. PLANTS SHALL NOT BE PLACED WITHIN 12 INCHES OF A SPRINKLER HEAD.
- CONTRACTOR SHALL BE RESPONSIBLE TO MAINTAIN ALL PLANT MATERIALS IN A HEALTHY STATE DURING CONSTRUCTION. ANY DAMAGE TO PLANT MATERIAL DUE TO NEGLIGENCE BY THE CONTRACTOR SHALL BE REPAIRED OR REPLACED AT THE CONTRACTOR'S EXPENSE.

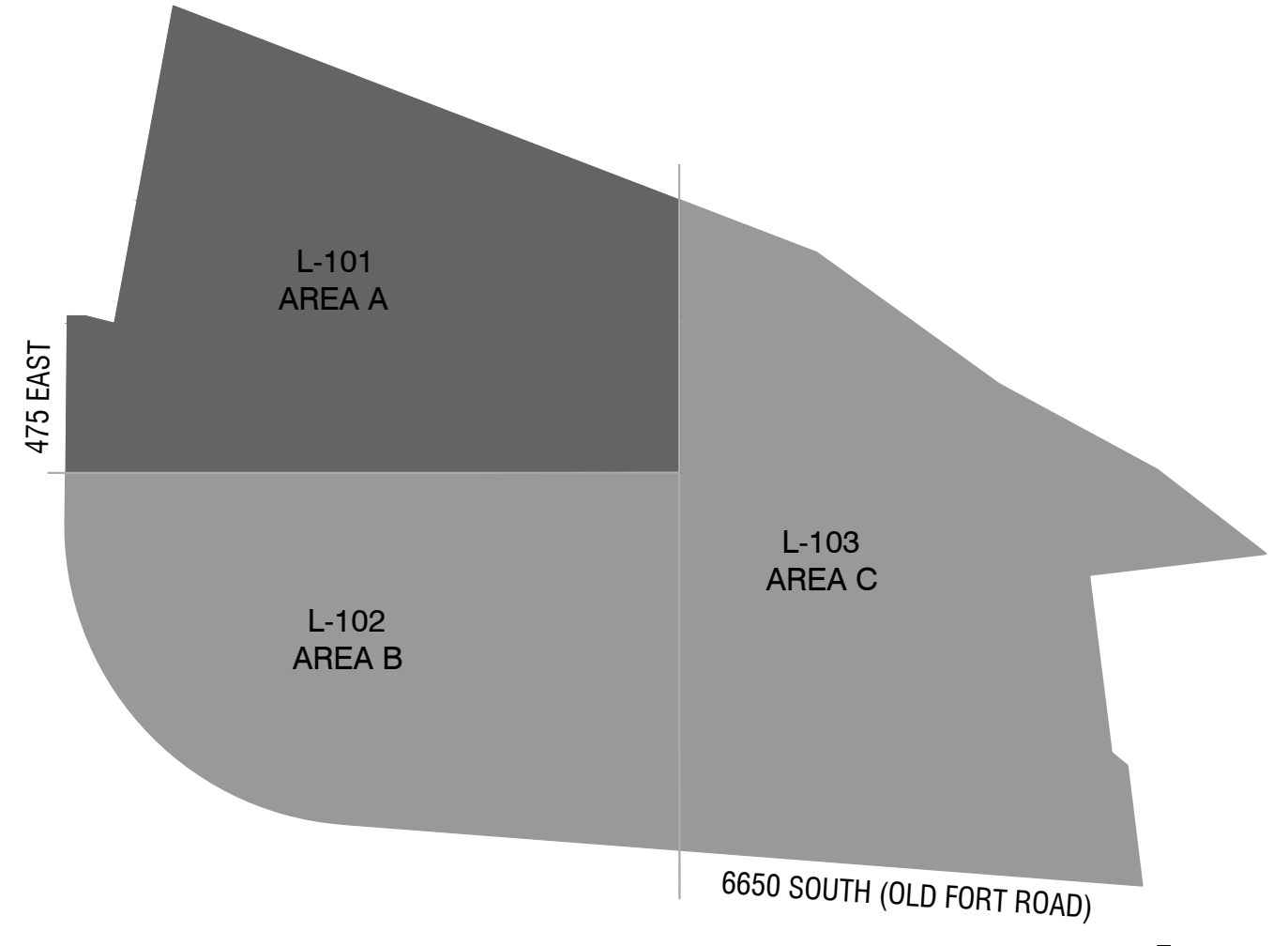

NOT FOR CONSTRUCTION

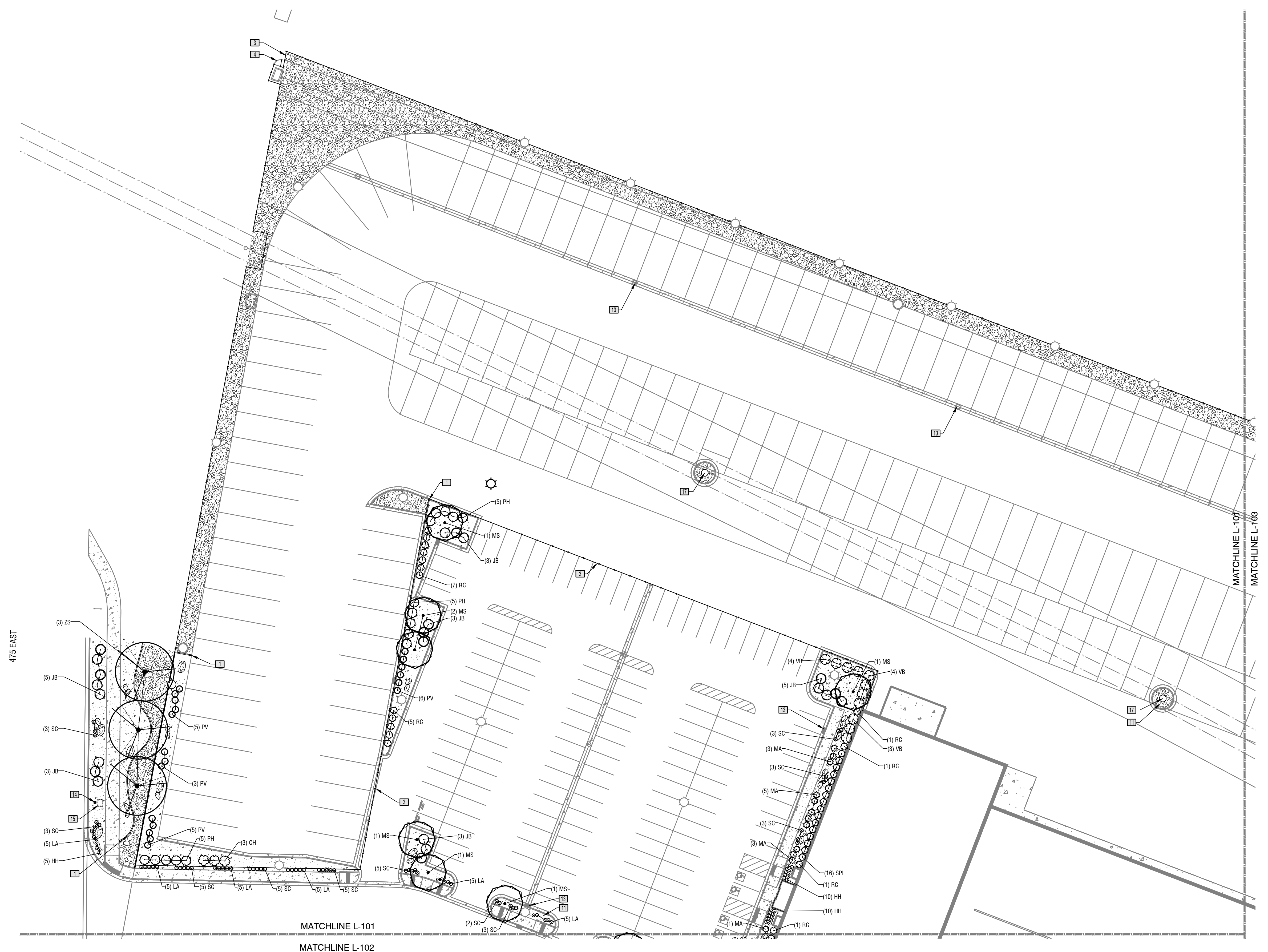

DESIGNED BY: J. CLEMENTS

RV GENERAL

CONSTRUCTION DOCUMENTS

SOUTH WEBER CITY, DAVIS COUNTY , UTAH

TRAFFIC CONTROL & SAFETY NOTES

1. BARRICADING AND DETOURING SHALL BE IN CONFORMANCE WITH THE REQUIREMENTS OF THE CURRENT STATE OF UTAH DEPARTMENT OF TRANSPORTATION MANUAL OF TRAFFIC CONTROLS FOR CONSTRUCTION AND MAINTENANCE WORK ZONES, AND THE CURRENT CITY STANDARD DRAWING, AND SHALL BE APPROVED BY THE CITY ENGINEER PRIOR TO ANY WORK.
2. NO STREET SHALL BE CLOSED TO TRAFFIC WITHOUT WRITTEN PERMISSION FROM THE CITY TRAFFIC ENGINEER, EXCEPT WHEN DIRECTED BY LAW ENFORCEMENT OR FIRE OFFICIALS.
3. THE CONTRACTOR SHALL MAKE EVERY EFFORT TO PROVIDE FOR SMOOTH TRAFFIC FLOW AND SAFETY. ACCESS SHALL BE MAINTAINED FOR ALL PROPERTIES ADJACENT TO THE WORK.
4. DETOURING OPERATIONS FOR A PERIOD OF SIX CONSECUTIVE CALENDAR DAYS, OR MORE, REQUIRE THE INSTALLATION OF TEMPORARY STREET STRIPING AND REMOVAL OF INTERFERING STRIPING BY SANDBLASTING. THE DETOURING STRIPING PLAN OR CONSTRUCTION TRAFFIC CONTROL PLAN MUST BE SUBMITTED TO THE CITY TRAFFIC ENGINEER FOR REVIEW AND APPROVAL.
5. ALL TRAFFIC CONTROL DEVICES SHALL BE RESTORED TO THEIR ORIGINAL CONDITION AT THE END OF THE WORK TO THE SATISFACTION OF THE CITY TRAFFIC ENGINEER
6. TRAFFIC CONTROL DEVICES (TCDs) SHALL REMAIN VISIBLE AND OPERATIONAL AT ALL TIMES.

UTILITY DISCLAIMER

THE CONTRACTOR IS SPECIFICALLY CAUTIONED THAT EXISTING UNDERGROUND UTILITIES AND IMPROVEMENTS ARE SHOWN IN THEIR APPROXIMATE LOCATIONS BASED UPON RECORD INFORMATION AVAILABLE AT THE TIME OF PREPARATION OF PLANS. LOCATIONS MAY NOT HAVE BEEN VERIFIED IN THE FIELD AND NO GUARANTEE IS MADE AS TO ACCURACY OR COMPLETENESS OF THE INFORMATION SHOWN. IT SHALL BE RESPONSIBILITY OF THE CONTRACTOR TO DETERMINE THE EXISTENCE AND LOCATION OF THOSE UTILITIES SHOWN ON THESE PLANS OR INDICATED IN THE FIELD BY LOCATING SERVICES. ANY ADDITIONAL COSTS INCURRED AS A RESULT OF CONTRACTOR'S FAILURE TO VERIFY LOCATIONS OF EXISTING UTILITIES PRIOR TO BEGINNING OF CONSTRUCTION IN THEIR VICINITY SHALL BE BORNE BY THE CONTRACTOR AND ASSUMED INCLUDED IN THE CONTRACT.

NOTICE TO CONTRACTOR

ALL CONTRACTORS AND SUBCONTRACTORS PERFORMING WORK SHOWN ON OR RELATED TO THESE PLANS SHALL CONDUCT THEIR OPERATIONS SO THAT ALL EMPLOYEES ARE PROVIDED A SAFE PLACE TO WORK AND THE PUBLIC IS PROTECTED. ALL CONTRACTORS AND SUBCONTRACTORS SHALL COMPLY WITH THE "OCCUPATIONAL SAFETY AND HEALTH REGULATIONS OF THE U.S. DEPARTMENT OF LABOR AND THE STATE OF UTAH DEPARTMENT OF INDUSTRIAL RELATIONS CONSTRUCTION SAFETY ORDERS". THE CIVIL ENGINEER SHALL NOT BE RESPONSIBLE IN ANY WAY FOR CONTRACTORS AND SUBCONTRACTORS COMPLIANCE WITH SAID REGULATIONS AND ORDERS.

CONTRACTOR FURTHER AGREES THAT HE SHALL ASSUME SOLE AND COMPLETE RESPONSIBILITY FOR JOB-SITE CONDITIONS DURING THE COURSE OF CONSTRUCTION OF THIS PROJECT, INCLUDING SAFETY OF ALL PERSONS AND PROPERTY, THAT THIS REQUIREMENT SHALL APPLY CONTINUOUSLY AND NOT BE LIMITED TO NORMAL WORKING HOURS, AND THAT THE CONTRACTOR SHALL DEFEND, INDEMNIFY AND HOLD THE OWNER AND THE CIVIL ENGINEER HARMLESS FROM ANY AND ALL LIABILITY, REAL OR ALLEGED IN CONNECTION WITH THE PERFORMANCE OF WORK ON THIS PROJECT, EXCEPTING FOR LIABILITY ARISING FROM THE SOLE NEGLIGENCE OF THE OWNER OR ENGINEER.

SANITARY SEWER GENERAL NOTES

1. ALL SANITARY SEWER CONSTRUCTION SHALL BE IN CONFORMANCE WITH CITY STANDARDS AND SPECIFICATIONS.
2. ALL GRAVITY SANITARY SEWER LINES SHALL BE SDR-35 PVC MATERIAL. SEWER LINE CONSTRUCTION AND MATERIALS SHALL CONFORM TO ASTM STANDARDS AND SPECIFICATIONS.
3. DISTANCES SHOWN ON PLANS ARE APPROXIMATE AND COULD VARY DUE TO VERTICAL ALIGNMENT.
4. RIM ELEVATIONS SHOWN ARE APPROXIMATE ONLY AND ARE NOT TO BE TAKEN AS FINAL ELEVATION. PIPELINE CONTRACTOR SHALL USE PRECAST CONCRETE ADJUSTMENT RINGS, GROUT AND STEEL SHIMS TO ADJUST THE MANHOLE FRAME TO THE REQUIRED FINAL GRADE IN CONFORMANCE WITH THE STANDARD SPECIFICATIONS. ALL FRAMES SHALL BE ADJUSTED TO FINAL GRADE.
5. ALL SANITARY SEWER MAIN TESTING SHALL BE IN ACCORDANCE WITH THE CITY STANDARDS AND SPECIFICATIONS. COPIES OF ALL TEST RESULTS SHALL BE PROVIDED TO THE PUBLIC WORKS SANITARY SEWER DEPARTMENT HEAD PRIOR TO FINAL ACCEPTANCE.
6. COMPACTION TESTING OF ALL TRENCHES WITH THE PROJECT SITE MUST BE ATTAINED AND RESULTS SUBMITTED TO THE CITY ENGINEER PRIOR TO FINAL ACCEPTANCE.
7. CONTRACTOR IS RESPONSIBLE TO PROTECT ALL EXISTING STRUCTURES AND IMPROVEMENTS DURING INSTALLATION OF SANITARY SEWER LINE.
8. WHERE CONNECTION TO EXISTING UTILITY IS PROPOSED, CONTRACTOR SHALL VERIFY LOCATION AND ELEVATION AND NOTIFY OWNER/ENGINEER IF LOCATION AND ELEVATION OF EXISTING UTILITY VARIES FROM THE DESIGN.
9. CAMERA TESTING AND PRESSURE TESTING PER CITY STANDARD.

GENERAL NOTES

1. ALL MATERIALS, WORKMANSHIP AND CONSTRUCTION OF SITE IMPROVEMENTS SHALL MEET OR EXCEED THE STANDARDS AND SPECIFICATIONS SET FORTH BY THE CITY ENGINEER, PLANNING, CODES AND SPECIFICATIONS AND APPLICABLE STATE AND FEDERAL REGULATIONS. WHERE THERE IS CONFLICT BETWEEN THESE PLANS AND SPECIFICATIONS, OR ANY APPLICABLE STANDARDS, THE HIGHER QUALITY STANDARD SHALL APPLY.
2. THE CONTRACTOR IS SPECIFICALLY CAUTIONED THAT THE LOCATION AND OR ELEVATION OF EXISTING UTILITIES, AS SHOWN ON THESE PLANS IS BASED ON RECORDS OF THE VARIOUS UTILITY COMPANIES AND WHERE POSSIBLE, MEASUREMENTS TAKEN IN THE FIELD. THE INFORMATION IS NOT TO BE RELIED UPON AS BEING EXACT OR COMPLETE. THE CONTRACTOR MUST CALL THE LOCAL UTILITY LOCATION CENTER AT LEAST 48 HOURS BEFORE ANY EXCAVATION TO REQUEST EXACT FIELD LOCATIONS OF THE UTILITIES. PRIOR TO CONSTRUCTION, THE CONTRACTOR SHALL VERIFY PERTINENT LOCATIONS AND ELEVATIONS, ESPECIALLY AT THE CONNECTION POINTS AND AT POTENTIAL UTILITY CONFLICTS. IT SHALL BE THE RESPONSIBILITY OF THE CONTRACTOR TO RELOCATE ALL EXISTING UTILITIES THAT CONFLICT WITH THE PROPOSED IMPROVEMENTS SHOWN ON THESE PLANS.
3. THE CONTRACTOR IS RESPONSIBLE FOR OBTAINING ALL NECESSARY PERMITS FROM ALL APPLICABLE AGENCIES. THE CONTRACTOR SHALL NOTIFY THE DESIGNATED PUBLIC WORKS INSPECTOR AT LEAST 48 HOURS PRIOR TO THE START OF ANY EARTH DISTURBING ACTIVITY, OR CONSTRUCTION ON ANY AND ALL PUBLIC IMPROVEMENTS.
4. THE CONTRACTOR SHALL COORDINATE AND COOPERATE WITH THE CITY AND ALL UTILITY COMPANIES INVOLVED WITH REGARD TO RELOCATIONS OR ADJUSTMENTS OF EXISTING UTILITIES DURING CONSTRUCTION AND TO ASSURE THAT THE WORK IS ACCOMPLISHED IN A TIMELY FASHION AND WITH A MINIMUM DISRUPTION OF SERVICE.
5. THE CONTRACTOR SHALL HAVE ONE (1) COPY OF APPROVED PLANS, AND ONE (1) COPY OF THE APPROPRIATE STANDARDS AND SPECIFICATIONS AND A COPY OF ANY PERMITS AND EXTENSION AGREEMENTS NEEDED FOR THE JOB, ON SITE AT ALL TIMES.
6. THE CONTRACTOR SHALL BE RESPONSIBLE FOR ALL ASPECTS OF SAFETY INCLUDING BUT NOT LIMITED TO, EXCAVATION, TRENCHING, SHORING, TRAFFIC CONTROL, AND SECURITY.
7. IF DURING THE CONSTRUCTION PROCESS CONDITIONS ARE ENCOUNTERED BY THE CONTRACTOR, HIS SUBCONTRACTORS, OR OTHER AFFECTED PARTIES, WHICH COULD INDICATE A SITUATION THAT IS NOT IDENTIFIED IN THE PLANS OR SPECIFICATIONS, THE CONTRACTOR SHALL CONTACT THE ENGINEER IMMEDIATELY.
8. THE CONTRACTOR IS RESPONSIBLE FOR PROVIDING ALL LABOR AND MATERIALS NECESSARY FOR THE COMPLETION OF THE INTENDED IMPROVEMENTS SHOWN ON THESE DRAWINGS OR DESIGNATED TO BE PROVIDED, INSTALLED, CONSTRUCTED, REMOVED AND RELOCATED UNLESS SPECIFICALLY NOTED OTHERWISE.
9. THE CONTRACTOR SHALL BE RESPONSIBLE FOR KEEPING ROADWAYS FREE AND CLEAR OF ALL CONSTRUCTION DEBRIS AND DIRT TRACKED FROM THE SITE.
10. THE CONTRACTOR SHALL BE RESPONSIBLE FOR RECORDING AS-BUILT DRAWINGS ON A SET OF RECORD DRAWINGS KEPT AT THE CONSTRUCTION SITE, AND AVAILABLE TO THE CITY INSPECTOR AT ALL TIMES.
11. THE CONTRACTOR SHALL SEQUENCE INSTALLATION OF UTILITIES IN SUCH A MANNER AS TO MINIMIZE POTENTIAL UTILITY CONFLICTS. IN GENERAL, STORM SEWER AND SANITARY SEWER SHOULD BE CONSTRUCTED PRIOR TO INSTALLATION OF WATER LINES AND DRY UTILITIES.
12. IT SHALL BE THE RESPONSIBILITY OF THE CONTRACTOR TO COORDINATE ALL UTILITY RELOCATIONS CONSISTENT WITH THE CONTRACTORS SCHEDULE FOR THIS PROJECT, WHETHER SHOWN OR NOT SHOWN AS IT RELATES TO THE CONSTRUCTION ACTIVITIES CONTEMPLATED IN THESE PLANS.

SWPPP GENERAL NOTES

1. CONTRACTOR SHALL OBTAIN ALL NECESSARY PERMITS AS REQUIRED BY THE CITY AND STATE.
2. ALL STRUCTURAL EROSION MEASURES SHALL BE INSTALLED AS SHOWN ON THE SWPPP PLAN, PRIOR TO ANY OTHER GROUND-DISTURBING ACTIVITY. ALL EROSION CONTROL MEASURES SHALL BE MAINTAINED IN GOOD REPAIR BY THE CONTRACTOR, UNTIL SUCH TIME AS THE ENTIRE DISTURBED AREAS ARE STABILIZED WITH HARD SURFACE OR LANDSCAPING.

STORM SEWER GENERAL NOTES

1. THE CONTRACTOR SHALL BE RESPONSIBLE FOR THE FOLLOWING:
 - A) OBTAIN ALL REQUIRED PERMITS FROM THE CITY OR REGULATORY AGENCIES, INCLUDING PERMITS TO WORK IN THE RIGHT-OF-WAY.
 - B) RESTORATION OF EXISTING IMPROVEMENTS INCLUDING BUT NOT LIMITED TO FENCES, SOD, LANDSCAPING, PAVEMENT, SPRINKLER SYSTEM.
 - C) VERIFICATION AND PROTECTION OF ALL EXISTING IMPROVEMENTS WITHIN THE LIMITS OF CONSTRUCTION.
 - D) PROVIDING AS-BUILT DRAWINGS TO THE CITY AND THE ENGINEER.
 - E) ALL PERMITTING, DEVELOPMENT, LOCATION, CONNECTION AND INSPECTION AND SCHEDULING FOR SUCH.
2. ALL STORM SEWER CONNECTIONS SHALL BE IN CONFORMANCE WITH CITY STANDARDS AND SPECIFICATIONS.
3. RIM ELEVATIONS SHOWN ARE APPROXIMATE ONLY AND ARE NOT TO BE TAKEN AS FINAL ELEVATION. PIPELINE CONTRACTOR SHALL USE PRECAST CONCRETE ADJUSTMENT RINGS, GROUT, AND STEEL SHIMS TO ADJUST THE MANHOLE FRAME TO THE REQUIRED FINAL GRADE IN CONFORMANCE WITH CITY STANDARDS AND SPECIFICATIONS AND PLANS. ALL FRAMES SHALL BE ADJUSTED TO FINAL GRADE PRIOR TO PLACEMENT OF ASPHALT PAVING.
4. COMPACTION OF ALL TRENCHES WITHIN THE PROJECT SITE MUST BE ATTAINED AND COMPACTION RESULTS SUBMITTED TO THE ENGINEER AND THE CITY PRIOR TO FINAL ACCEPTANCE.
5. ALL STORM DRAIN PIPES IN THE CITY RIGHT-OF-WAY SHALL BE RCP CL III.
6. ALL STORM SEWER MANHOLES IN PAVED AREAS SHALL BE FLUSH WITH THE PAVEMENT AND SHALL HAVE TRAFFIC BEARING LIDS. ALL STORM SEWER LIDS SHALL BE LABELED "STORM DRAIN".
7. WHERE CONNECTION TO EXISTING UTILITY IS PROPOSED, CONTRACTOR SHALL VERIFY LOCATION AND ELEVATION AND NOTIFY OWNER/ENGINEER IF LOCATION AND ELEVATION OF EXISTING UTILITY VARIES FROM THE DESIGN.

GENERAL GRADING NOTES

1. ALL WORK SHALL BE IN ACCORDANCE WITH THE LATEST APWA STANDARDS AND SPECIFICATION FOR PUBLIC WORKS AND THE CITY STANDARDS. CONTRACTOR SHALL ENSURE POSITIVE DRAINAGE AWAY FROM BUILDING FOUNDATIONS AND ENTRIES. FINISHED GRADE AT FOUNDATION FOR WOOD FRAMED STRUCTURES SHALL BE 8 INCHES BELOW TOP OF FOUNDATION AND DRAINAGE SHALL BE A MINIMUM OF 5% WITHIN 10 FEET FROM THE BUILDING.
2. MAXIMUM SLOPES SHALL BE 3:1 FOR CUT AND FILL UNLESS OTHERWISE NOTED.
3. COMPACTION REQUIREMENTS AND TESTING SHALL BE PERFORMED TO MEET THE CITY STANDARDS.
4. NO FILL SHALL BE PLACED UNTIL VEGETATION HAS BEEN REMOVED AND SUB-GRADE PREPARED PER THE SOILS REPORT.
5. DUST SHALL BE CONTROLLED BY WATERING OR OTHER APPROVED METHODS.
6. CONTRACTOR SHALL COMPLY WITH STORM WATER POLLUTION PREVENTION PLAN BY INSTALLING BMP'S PRIOR TO COMMENCEMENT OF EXCAVATION ACTIVITIES. CONTACT THE CITY INSPECTOR FOR INSPECTION.
7. ALL RECOMMENDATIONS OF THE GEOTECHNICAL REPORT AND ALL SUBSEQUENT REPORTS, ADDENDUM ETC. SHALL BE CONSIDERED A PART OF THIS GRADING PLAN AND SHALL BE COMPLIED WITH.
8. THE CONTRACTOR SHALL CONTACT BLUE STAKES FOR LOCATION MARKING PRIOR TO COMMENCING EXCAVATION ACTIVITIES.
9. CITY MAY REQUIRE A PRE-CONSTRUCTION MEETING BEFORE A PERMIT IS ISSUED.
10. STREETS ADJACENT TO THE PROJECT SHALL BE CLEAN AT ALL TIMES.
11. CONTRACTOR IS RESPONSIBLE FOR ARRANGING FOR ALL REQUIRED INSPECTIONS.
12. PRIOR TO TAKING WATER FROM A CITY FIRE HYDRANT, THE CONTRACTOR SHALL MAKE ARRANGEMENTS WITH THE WATER UTILITY TO OBTAIN A WATER METER.

CULINARY WATER GENERAL NOTES

1. ALL INSTALLATION AND MATERIALS SHALL CONFORM TO WATER UTILITY STANDARDS, SPECIFICATIONS AND PLANS.
2. THRUST BLOCKING IS REQUIRED AT ALL BENDS AND FITTINGS. TIE RODS SHALL BE USED AT ALL BENDS AND FITTINGS WHERE THRUST BLOCKS DO NOT BEAR AGAINST UNDISTURBED SOIL.
3. ALL WATERLINES AT SEWER CROSSINGS SHALL BE LOCATED ABOVE AND HAVE AN 18-INCH VERTICAL SEPARATION FROM THE SEWER PIPE. IF THIS IS NOT PROVIDED, THE WATERLINE SHALL BE INSTALLED WITH 20 L.F. OF CONCRETE CASING CENTERED OVER THE SEWER PIPE.
4. DISINFECTION TESTS SHALL BE PERFORMED BY THE WATER UTILITY WITH COOPERATION FROM THE CONTRACTOR IN PERFORMING ANY NECESSARY EXCAVATION AND SUBSEQUENT BACKFILLING AT NO COST TO THE CITY.
5. CHLORINATION OF COMPLETED WATER LINE. THE NEW WATER LINES SHALL BE DISINFECTED BY CHLORINATION. THE CONTRACTOR WILL BE RESPONSIBLE FOR ALL RELATED COSTS AND FEES RELATED TO THE CHLORINATION OF THE COMPLETED WATER LINE. THIS TEST SHALL BE PERFORMED PRIOR TO CONNECTION OF THE NEW WATER LINES TO THE EXISTING WATER SYSTEM. THE CONTRACTOR SHALL NOTIFY THE WATER UTILITY AT LEAST 24 HOURS BEFORE THE CHLORINATION IS DESIRED.
6. A MINIMUM HORIZONTAL CLEARANCE OF 10 FEET SHALL BE MAINTAINED FROM SANITARY SEWER MAINS.
7. UNLESS OTHERWISE SPECIFIED, ALL WATERLINES SHALL BE AWWA C900 PVC CLASS 150, PER ASTM D2241.
8. CONTRACTOR SHALL LOCATE VALVES PRIOR TO CONNECTION WITH EXISTING SYSTEM, BUT SHALL NOT OPERATE ANY VALVE WITHOUT PERMISSION FROM THE WATER UTILITY.
9. ALL WATER MAINS, VALVES, FIRE HYDRANTS, SERVICES AND APPURTENANCES SHALL BE INSTALLED, TESTED, AND APPROVED PRIOR TO PAVING.
10. THERE SHALL BE A WATER SUPPLY TO THE DEVELOPMENT BEFORE ANY WOOD CONSTRUCTION STARTS.
11. THE WATER UTILITY REQUIRES THE USE OF CORROSION RESISTANT MATERIALS FOR ALL CULINARY WATER IMPROVEMENTS. SPECIFICALLY, ROMAC BLUE BOLTS OR STAINLESS STEEL BOLTS MUST BE USED ON ALL FITTINGS. FURTHER, ALL METAL FITTINGS SHALL BE POLY WRAPPED.

ALL IMPROVEMENTS TO CONFORM TO CURRENT CITY STANDARDS AND SPECIFICATIONS
 CULINARY WATER IMPROVEMENTS TO CONFORM TO THE WATER UTILITY'S STANDARDS AND SPECIFICATIONS
 SECONDARY WATER IMPROVEMENTS TO CONFORM TO THE SECONDARY WATER UTILITY'S STANDARDS AND SPECIFICATIONS

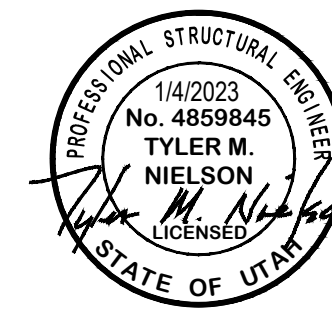

RV GENERAL
 CONSTRUCTION DOCUMENTS

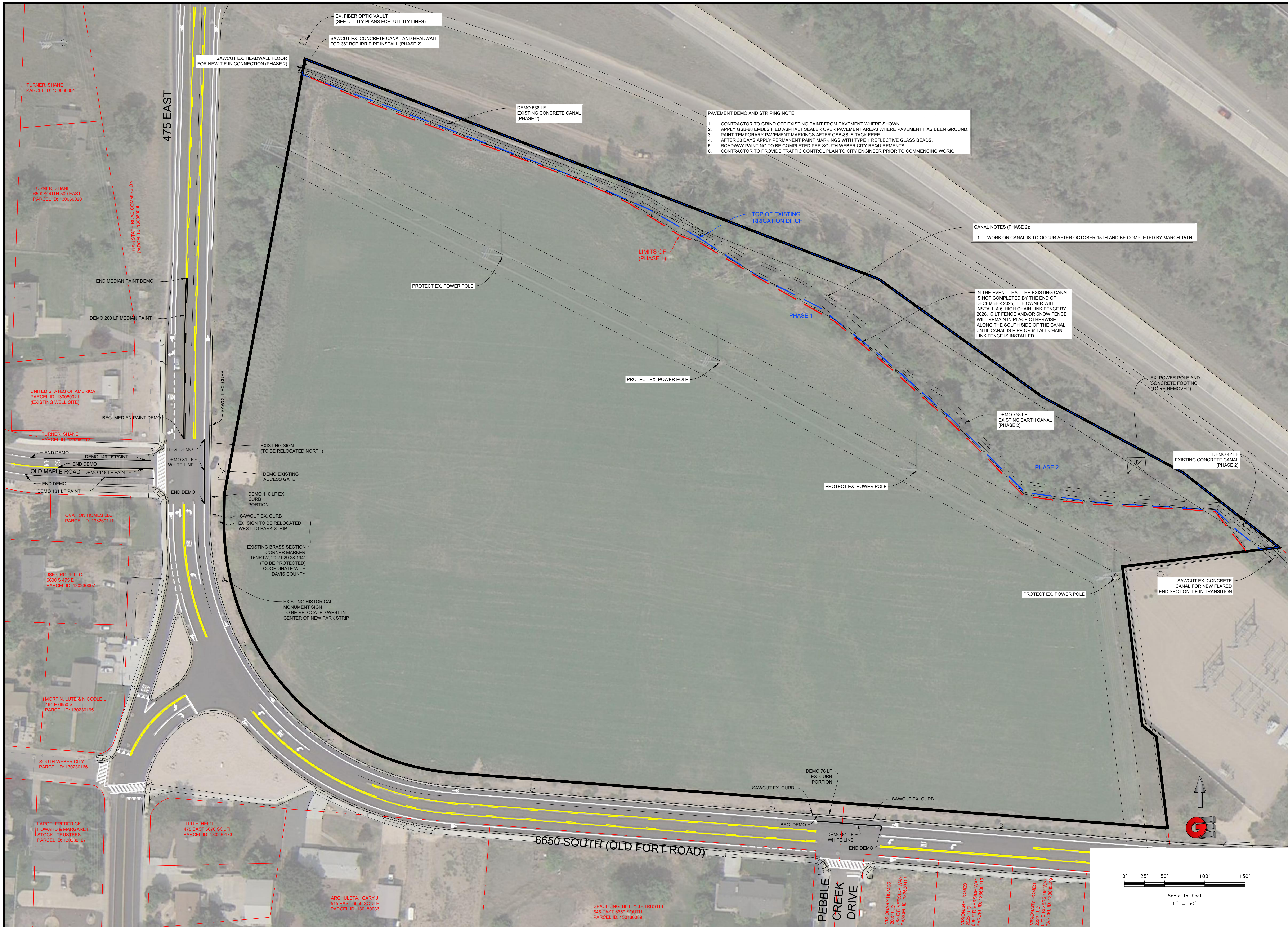

EX. FIBER OPTIC VAULT
(SEE UTILITY PLANS FOR UTILITY LINES)

SAWCUT EX. CONCRETE CANAL AND HEADWALL
FOR 36" RCP IRR PIPE INSTALL (PHASE 2)

SAWCUT EX. HEADWALL FLOOR
FOR NEW TIE IN CONNECTION (PHASE 2)

DEMO 538 LF
EXISTING CONCRETE CANAL
(PHASE 2)

PAVEMENT DEMO AND STRIPING NOTE:
 1. CONTRACTOR TO GRIND OFF EXISTING PAINT FROM PAVEMENT WHERE SHOWN.
 2. APPLY GSB-88 EMULSIFIED ASPHALT SEALER OVER PAVEMENT AREAS WHERE PAVEMENT HAS BEEN GROUND.
 3. PAINT TEMPORARY PAVEMENT MARKINGS AFTER GSB-88 IS TACK FREE.
 4. AFTER 30 DAYS APPLY PERMANENT PAINT MARKINGS WITH TYPE 1 REFLECTIVE GLASS BEADS.
 5. ROADWAY PAINTING TO BE COMPLETED PER SOUTH WEBER CITY REQUIREMENTS.
 6. CONTRACTOR TO PROVIDE TRAFFIC CONTROL PLAN TO CITY ENGINEER PRIOR TO COMMENCING WORK.

CANAL NOTES (PHASE 2):
 1. WORK ON CANAL IS TO OCCUR AFTER OCTOBER 15TH AND BE COMPLETED BY MARCH 15TH.

IN THE EVENT THAT THE EXISTING CANAL IS NOT COMPLETED BY THE END OF DECEMBER 2025, THE OWNER WILL INSTALL A 6' HIGH CHAIN LINK FENCE BY 2026. SILT FENCE AND/OR SNOW FENCE WILL REMAIN IN PLACE OTHERWISE ALONG THE SOUTH SIDE OF THE CANAL UNTIL CANAL IS PIPE OR 6' TALL CHAIN LINK FENCE IS INSTALLED.

EX. POWER POLE AND CONCRETE FOOTING
(TO BE REMOVED)

DEMO 42 LF
EXISTING CONCRETE CANAL
(PHASE 2)

DEMO 758 LF
EXISTING EARTH CANAL
(PHASE 2)

SAWCUT EX. CONCRETE CANAL FOR NEW FLARED END SECTION TIE IN TRANSITION

PROTECT EX. POWER POLE

PROTECT EX. POWER POLE

PROTECT EX. POWER POLE

PROTECT EX. POWER POLE

475 EAST

6650 SOUTH (OLD FORT ROAD)

PEBBLE CREEK DRIVE

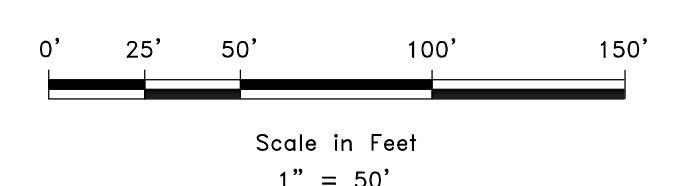

SCALE	1"=50'
DATE	1/4/2023
DESIGN	WJS
DRAWN	WJS
CHECKED	TJM
DWG.	REVISED - SOUTH WEBER LIC. 2021 - GENERAL BY SOUTH WEBER/CIVIL/PLANNING

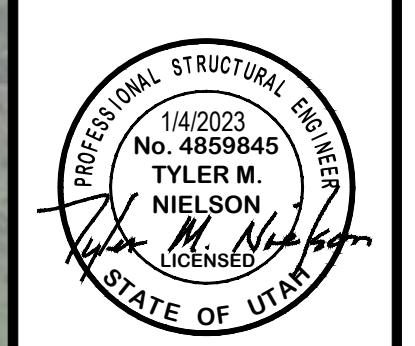

EXISTING STRIPING + DEMO PLAN
 RV GENERAL
 546 EAST OLD FORT ROAD
 SOUTH WEBER CITY, DAVIS COUNTY, UTAH

GARDNER ENGINEERING
 CIVIL • LAND PLANNING
 MUNICIPAL • LAND SURVEYING

5150 SOUTH 375 EAST OGDEN, UT
 OFFICE: 801-476-0202 FAX: 801-476-0066

CE0-01

TURNER, SHANE
PARCEL ID. 130060004

TURNER, SHANE
880 SOUTH 500 EAST
PARCEL ID. 130060020

UTAH STATE RACING COMMISSION
PARCEL ID. 100000000

UNITED STATES OF AMERICA
PARCEL ID. 130060021
(EXISTING WELL SITE)

TURNER, SHANE
PARCEL ID. 130060012

END DEMO
DEMO 149 LF PAINT
END DEMO
DEMO 81 LF WHITE LINE
OLD MAPLE ROAD DEMO 118 LF PAINT
END DEMO
DEMO 161 LF PAINT

Ovation Homes LLC
PARCEL ID. 133260111

JSE GROUP LLC
6800 S 476 E
PARCEL ID. 130230007

MORFIN, LUTE & NICOLE L
464 E 6650 S
PARCEL ID. 130230165

SOUTH WEBER CITY
PARCEL ID. 130230166

LARGE, FREDERICK
HOWARD & MARGARET
STOCK - TRUSTEES
PARCEL ID. 130230167

LITTLE, HEIDI
475 EAST 6670 SOUTH
PARCEL ID. 130230173

ARCHULETA, GARY J
515 EAST 8650 SOUTH
PARCEL ID. 130180096

SPAUDLING, BETTY J - TRUSTEE
545 EAST 6650 SOUTH
PARCEL ID. 130180098

EXISTING SIGN
(TO BE RELOCATED NORTH)

DEMO EXISTING ACCESS GATE

DEMO 110 LF EX. CURB PORTION

SAWCUT EX. CURB
EX. SIGN TO BE RELOCATED WEST TO PARK STRIP

EXISTING BRASS SECTION CORNER MARKER
TSNR1W, 20 21 29 28 1941
(TO BE PROTECTED)
COORDINATE WITH DAVIS COUNTY

EXISTING HISTORICAL MONUMENT SIGN
TO BE RELOCATED WEST IN CENTER OF NEW PARK STRIP

END MEDIAN PAINT DEMO

DEMO 200 LF MEDIAN PAINT

SAWCUT EX. CURB

BEG. MEDIAN PAINT DEMO

BEG. DEMO

TOP OF EXISTING IRRIGATION DITCH

LIMITS OF (PHASE 1)

PHASE 1

PHASE 2



POWER NOTES:

- NO FLAMMABLES, INCLUDING BUT NOT LIMITED TO PROPANE TANKS, FIRE PITS, ETC. ARE ALLOWED WITHIN THE TRANSMISSION EASEMENT AREA.
- WITHIN 12 HOURS OF ADVANCED NOTICE AREA, ANY TRAILERS (OR OTHER ITEMS) WITHIN THE AREA SHOWN IN RED, WHICH AREA IS 60' FROM POWER POLE ON THREE SIDES WILL BE TEMPORARILY RELOCATED FOR RMP TO MAINTAIN LINES AND MANEUVER ANY AND ALL EQUIPMENT, AS MAY BE REQUIRED.

TOTAL SITE = 782,982 SF
 ONSITE XEROSCAPE LANDSCAPING = 78,439 SF (10%)
 144 PARKING STALLS
 435 RV PARKING STALLS
 HEAVY DUTY ASPHALT
 STANDARD ASPHALT
 TOTAL OFF SITE = SF
 OFF SITE LANDSCAPING = 15,278 SF
 OFF SITE SIDEWALK = 12,005 SF

IN THE EVENT THAT THE EXISTING CANAL IS NOT COMPLETED BY THE END OF DECEMBER 2025, THE OWNER WILL INSTALL A 6' HIGH CHAIN LINK FENCE BY 2026. SILT FENCE AND/OR SNOW FENCE WILL REMAIN IN PLACE OTHERWISE ALONG THE SOUTH SIDE OF THE CANAL UNTIL CANAL IS PIPE OR 6' TALL CHAIN LINK FENCE IS INSTALLED.

SCALE: 1"=50'

DATE: 1/4/2023

DESIGN: WJS

DRAWN: WJS

CHECKED: TMN

REVISIONS	DESCRIPTION
DATE	

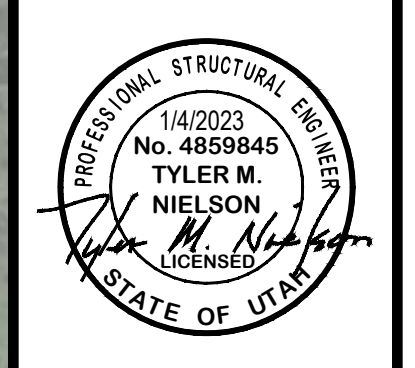

SITE PLAN

RV GENERAL

546 EAST OLD FORT ROAD

SOUTH WEBER CITY, DAVIS COUNTY, UTAH

GARDNER ENGINEERING

CIVIL-LAND PLANNING

MUNICIPAL-LAND SURVEYING

5150 SOUTH 375 EAST OGDEN, UT

OFFICE: 801-476-0202 FAX: 801-476-0066

CE1-01

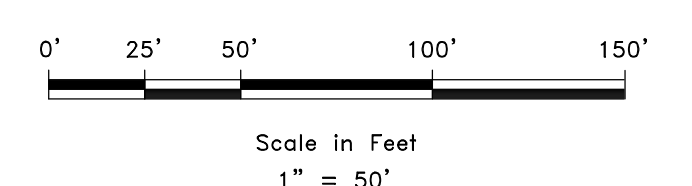

NOTE: SEE SHEET CE1-02 FOR OFFSITE STRIPING PLAN

NOTE: SEE PLANS BY OTHERS FOR FUELING TANKS.

NOTE: SEE SHEET CE1-02 FOR OFFSITE STRIPING PLAN

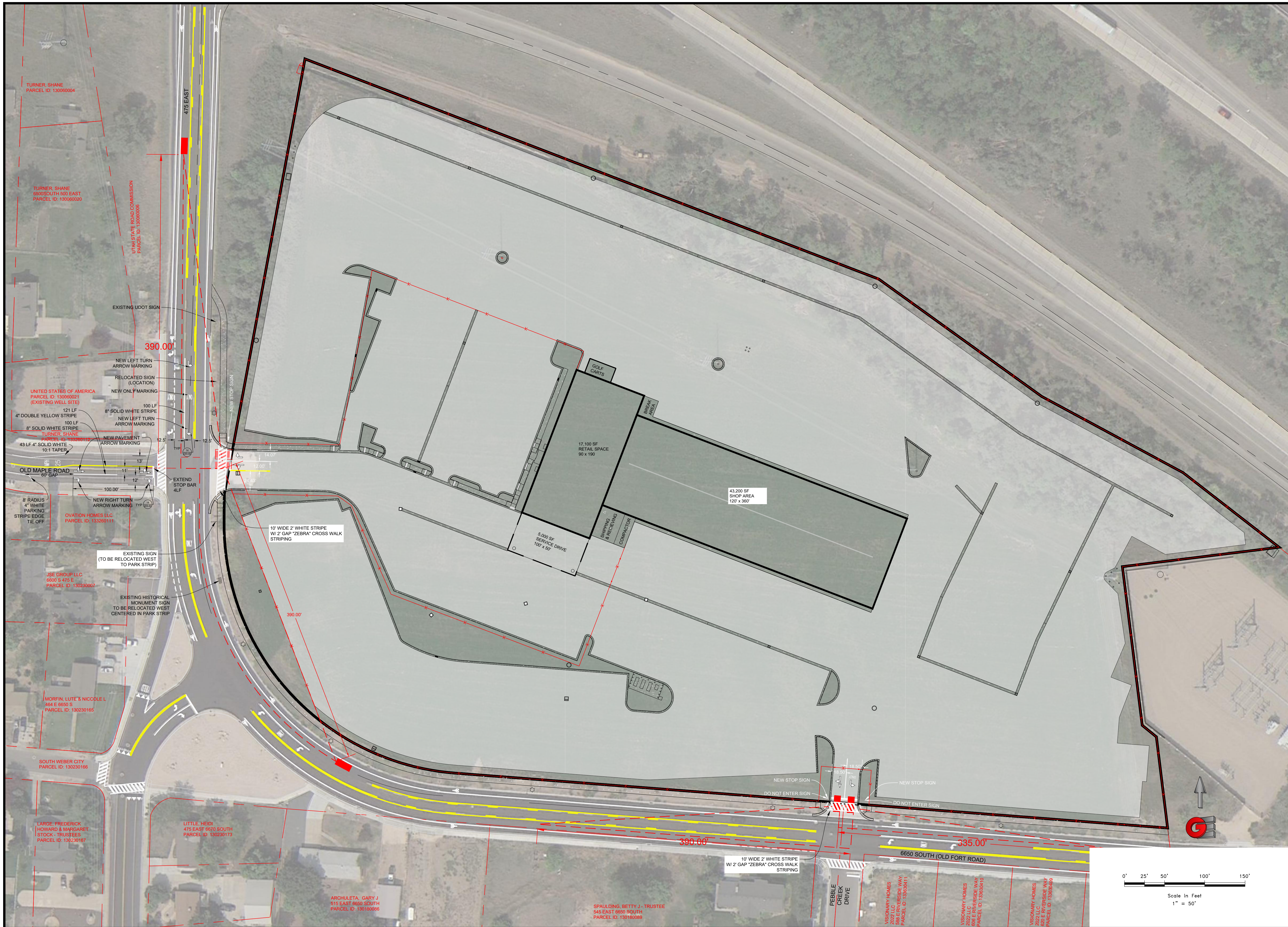

REVISIONS	DESCRIPTION
DATE	

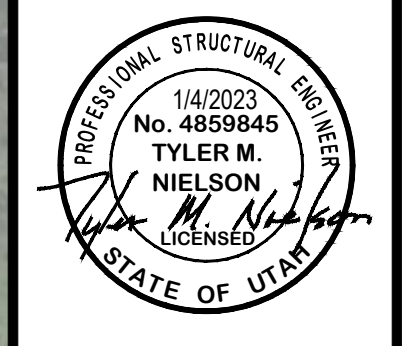

OFF SITE STRIPING PLAN
 RV GENERAL
 546 EAST OLD FORT ROAD
 SOUTH WEBER CITY, DAVIS COUNTY, UTAH

GARDNER ENGINEERING
 CIVIL - LAND PLANNING
 MUNICIPAL - LAND SURVEYING

5150 SOUTH 375 EAST OGDEN, UT
 OFFICE: 801.476.0202 FAX: 801.476.0066

CE1-02

SCALE: 1"=50'
 DATE: 1/4/2023
 DESIGN: WJS
 DRAWN: WJS
 CHECKED: TMN
 DWG: 8/1/182 - SOUTH WEBER, LIC.2511 - GENERAL BY SOUTH WEBER/CIVIL/SITE PLANNING

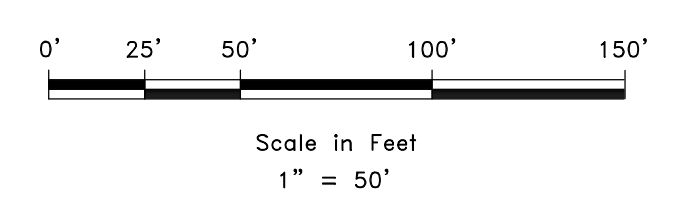

EROSION CONTROL NOTES:

1. SANDBAGS WILL BE PLACED AT DISCHARGE LOCATIONS TO CONTAIN AND DIVERT STORM WATER THROUGH THE INLET PROTECTION.
2. AN EARTHEN BERM 6" HIGH WILL BE CONSTRUCTED TO CONTAIN THE STORM WATER AND DIVERT IT TO DISCHARGE AREAS.
3. STORM WATER WILL BE DISCHARGED INTO AN EXISTING DRAINAGE SYSTEM. EXISTING LINES SHALL BE INSPECTED PRIOR TO CERTIFICATE OF OCCUPANCY AND CLEANED IF NECESSARY.
4. THE STORM WATER POLLUTION PREVENTION PLAN SHALL CONFORM TO ALL STATE DIVISION OF ENVIRONMENTAL PROTECTION REGULATIONS.

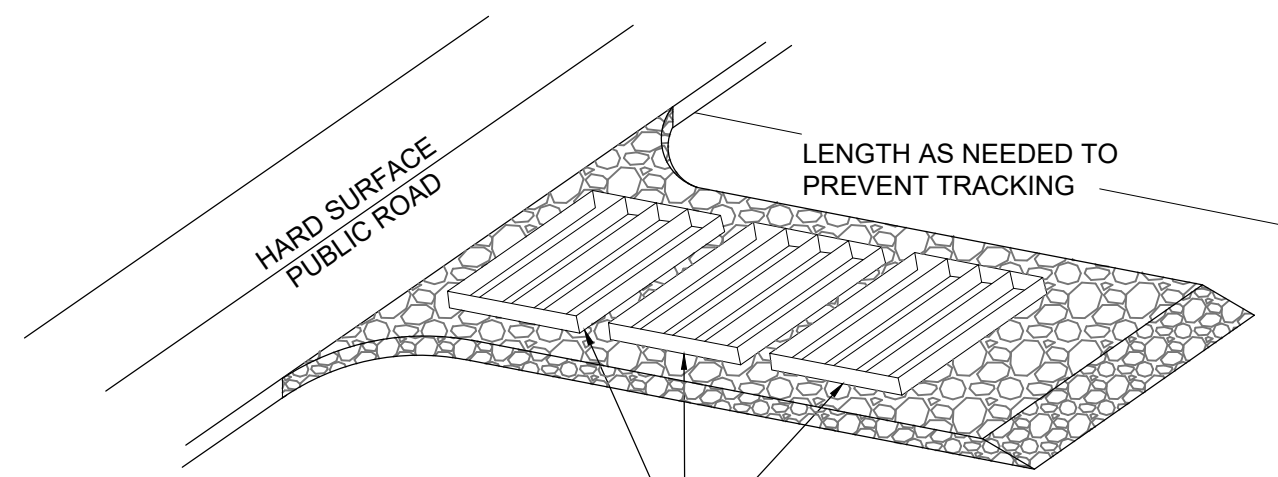
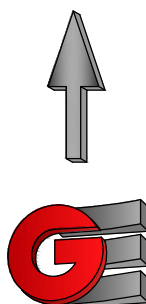

ENTRANCE STABILIZATION NOTES:

1. SEDIMENTS AND OTHER MATERIALS SHALL NOT BE TRACKED FROM THE SITE BY VEHICLE TRAFFIC. THE CONSTRUCTION ENTRANCE ROADWAYS SHALL BE STABILIZED SO AS TO PREVENT SEDIMENTS FROM BEING DEPOSITED INTO THE STORM DRAIN SYSTEMS. DEPOSITIONS MUST BE SWEEPED UP IMMEDIATELY AND MAY NOT BE WASHED DOWN BY RAIN OR OTHER MEANS INTO THE STORM DRAIN SYSTEM.
2. STABILIZED CONSTRUCTION ENTRANCE SHALL BE:
 - a. LOCATED AT ANY POINT WHERE TRAFFIC WILL BE ENTERING OR LEAVING A CONSTRUCTION SITE TO OR FROM A PUBLIC RIGHT-OF-WAY, STREET, ALLEY AND SIDEWALK OR PARKING AREA.
 - b. A SERIES OF STEEL PLATES WITH "RUMBLE STRIPS", AND/OR MIN. 3" COARSE AGGREGATE WITH LENGTH, WIDTH AND THICKNESS AS NEEDED TO ADEQUATELY PREVENT ANY TRACKING ONTO PAVED SURFACES.
3. ADDING A WASH RACK WITH A SEDIMENT TRAP LARGE ENOUGH TO COLLECT ALL WASH WATER CAN GREATLY IMPROVE EFFICIENCY.
4. ALL VEHICLES ACCESSING THE CONSTRUCTION SITE SHALL UTILIZE THE STABILIZED CONSTRUCTION ENTRANCE SITES.

STREET MAINTENANCE NOTES:

1. REMOVE ALL SEDIMENT DEPOSITED ON PAVED ROADWAYS IMMEDIATELY.
2. SWEEP PAVED AREAS THAT RECEIVE CONSTRUCTION TRAFFIC WHENEVER SEDIMENT BECOMES VISIBLE.
3. PAVEMENT WASHING WITH WATER IS PROHIBITED IF IT RESULTS IN A DISCHARGE TO THE STORM DRAIN SYSTEM.

NOTE:

CONTRACTOR SHALL COMPLETE AND SUBMIT A STATE NOTICE OF INTENT (NOI) AND A STORM WATER POLLUTION PREVENTION PLAN BOOKLET

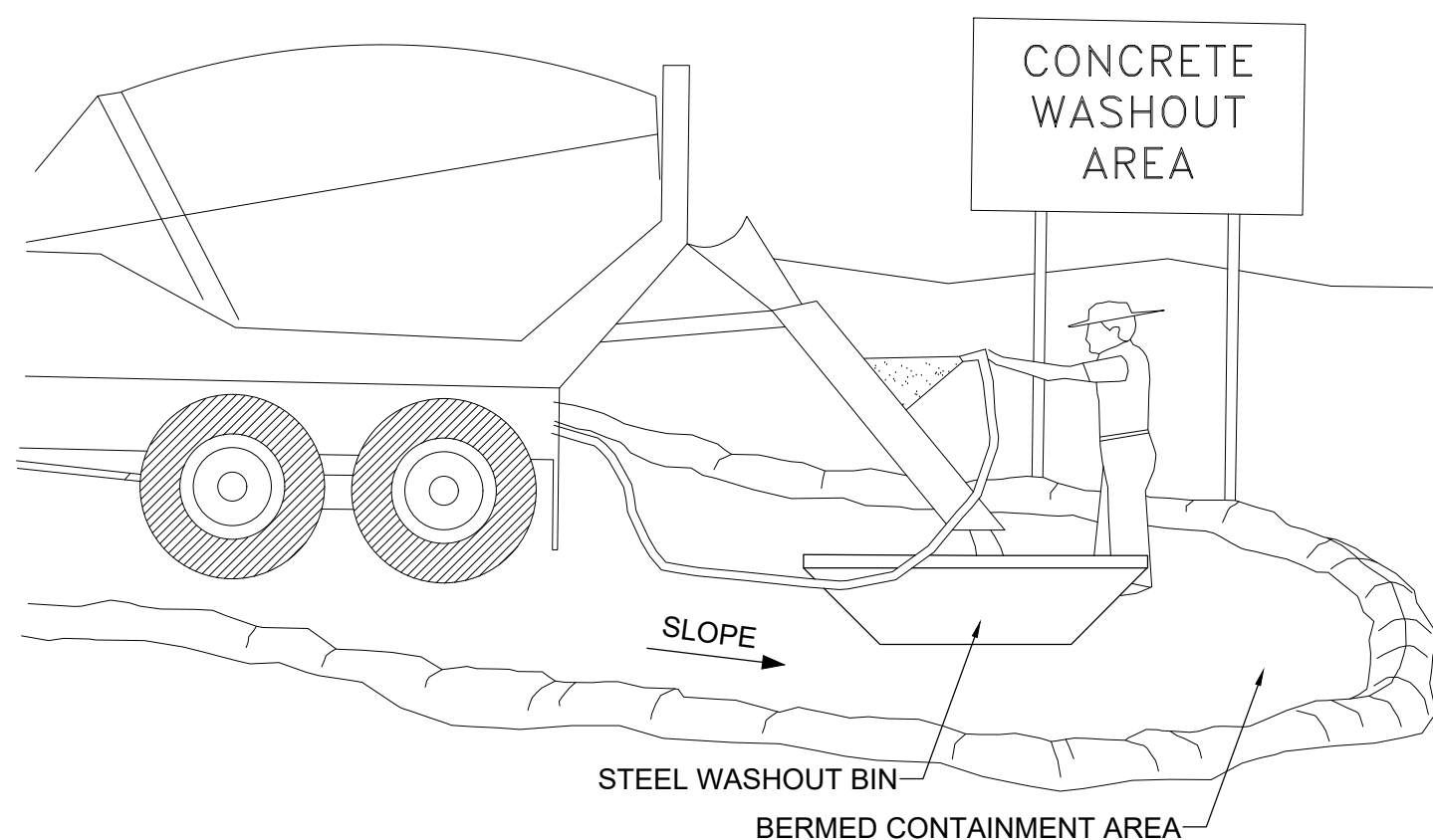

NOTES:

1. EXCESS AND WASTE CONCRETE SHALL BE DISPOSED OF OFF SITE OR AT DESIGNATED AREAS ONLY.
2. EXCESS AND WASTE CONCRETE SHALL NOT BE WASHED INTO THE STREET OR INTO A DRAINAGE SYSTEM.
3. FOR WASHOUT OF CONCRETE AND MORTAR PRODUCTS ONSITE, A DESIGNATED CONTAINMENT FACILITY OF SUFFICIENT CAPACITY TO RETAIN LIQUID AND SOLID WASTE SHALL BE PROVIDED.
4. ONSITE CONCRETE WASHOUT CONTAINMENT FACILITY SHALL BE A STEEL BIN OR APPROVED ALTERNATE.
5. SLURRY FROM CONCRETE AND ASPHALT SAW CUTTING SHALL BE VACUUMED OR CONTAINED, DRIED, PICKED UP AND DISPOSED OF PROPERLY.



INLET PROTECTION (EITHER OPTION)



SILT FENCE

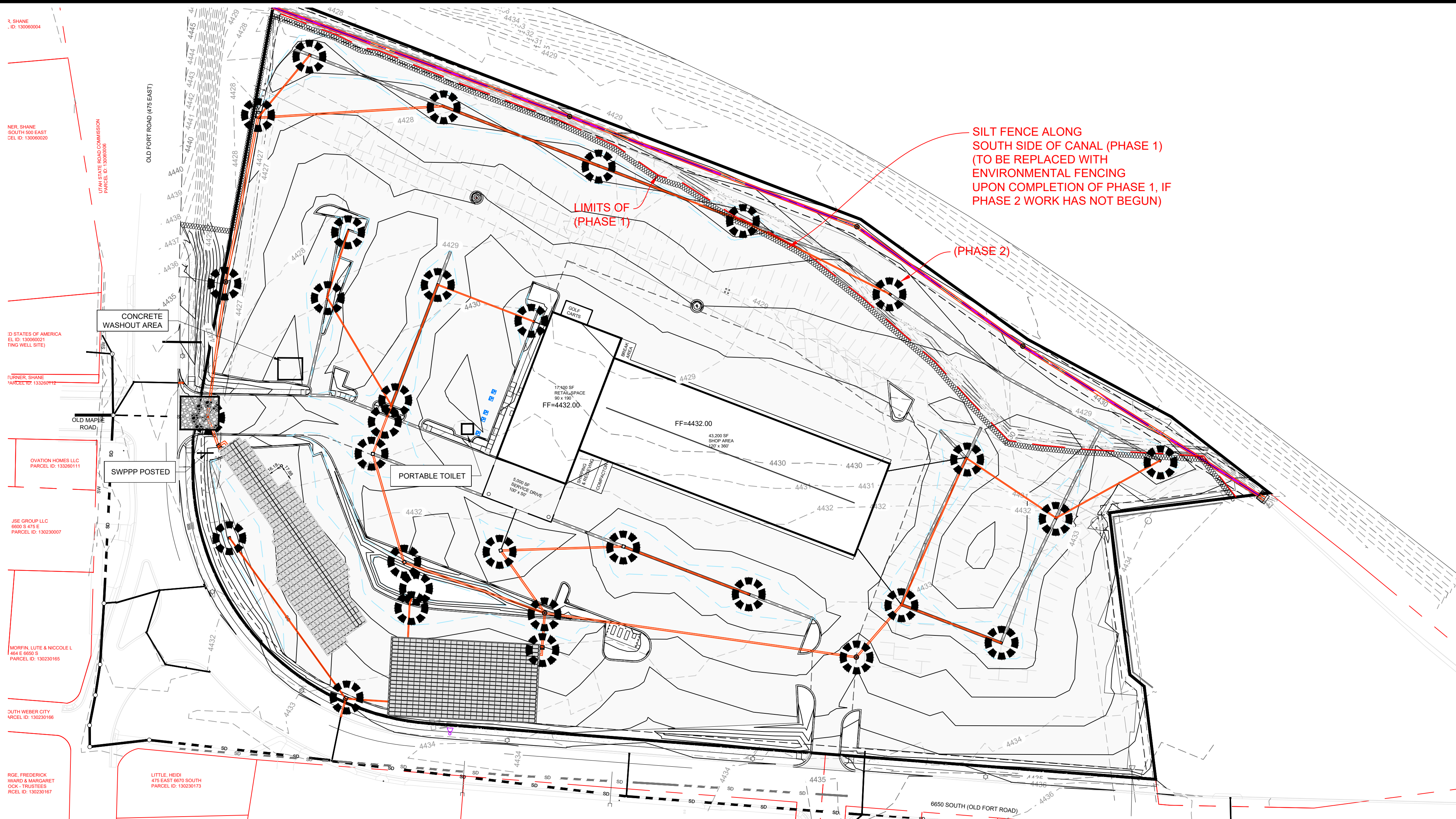

INSTALLATION NOTES

1. PLACEMENT: PLACE CG TIGHTLY AGAINST CURB OPENING AND COVER ENTIRE GRATE. CG SHOULD EXTEND AT LEAST 2 INCHES PAST GRATE TOWARDS STREET.
2. OVERLAP FOR LONG OPENINGS: OVERLAP CG UNITS AT LONGER OPENINGS.
3. ANCHOR: ANCHOR CG SO THAT WATER CANNOT FLOW BEHIND IT.
4. ALTERNATE ANCHOR METHODS: A) INSTALL GRAVEL BAGS AT EACH SIDE OF CG - HALF-ON AND HALF-OFF THE EDGES. USE HALF-FILLED GRAVEL BAGS (15 OR 20 LBS). ROUND ROCK IS RECOMMENDED. OR B) ATTACH WITH 16 GAUGE TIE-WIRE. CUT WIRE TO 18" LENGTH. AT EACH CORNER OF CG, FEED ONE END OF WIRE DOWN THROUGH CG, AROUND GRATE BAR, AND BACK UP THRU CG, ABOVE GROUND, TWIST WIRES SEVERAL TIMES, CUT-OFF EXCESS. OR C) FASTEN WITH CONCRETE ANCHORS/NAILS AT THE OUTSIDE EDGES OF CG.

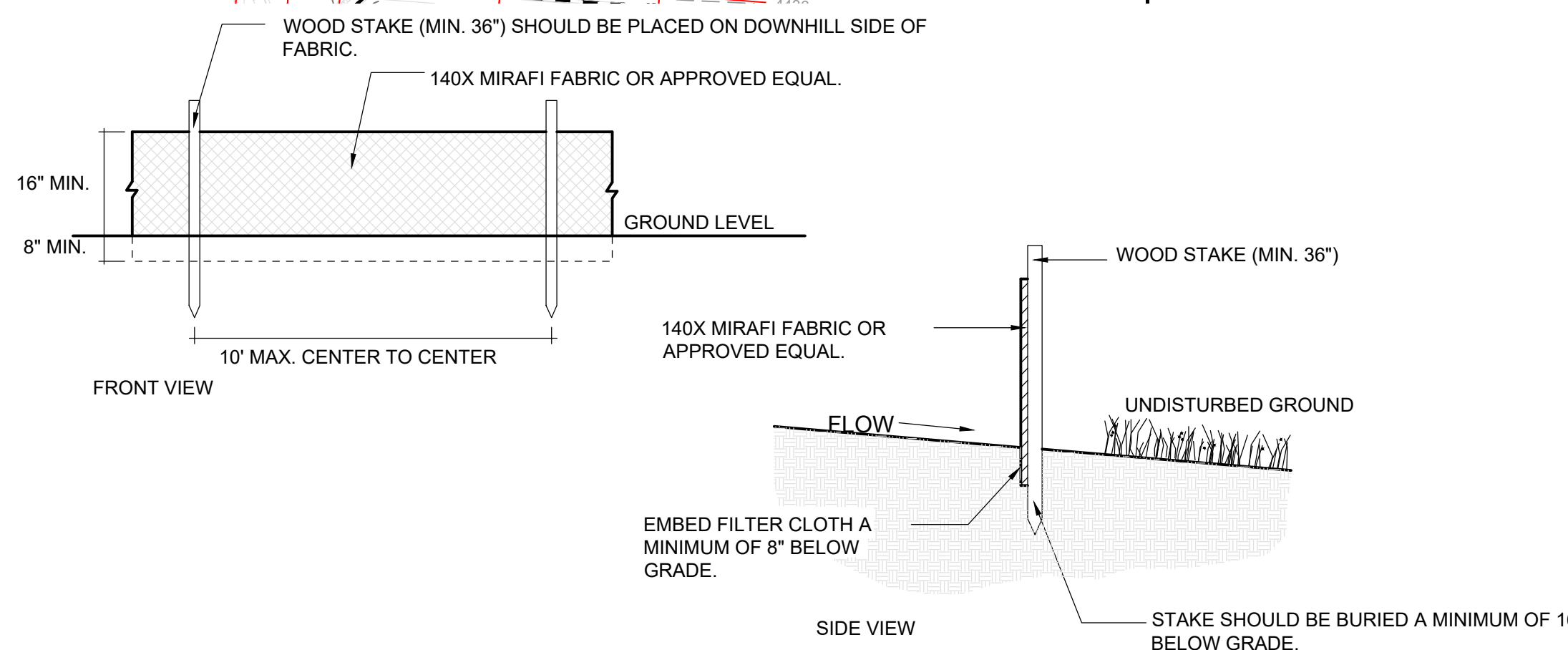
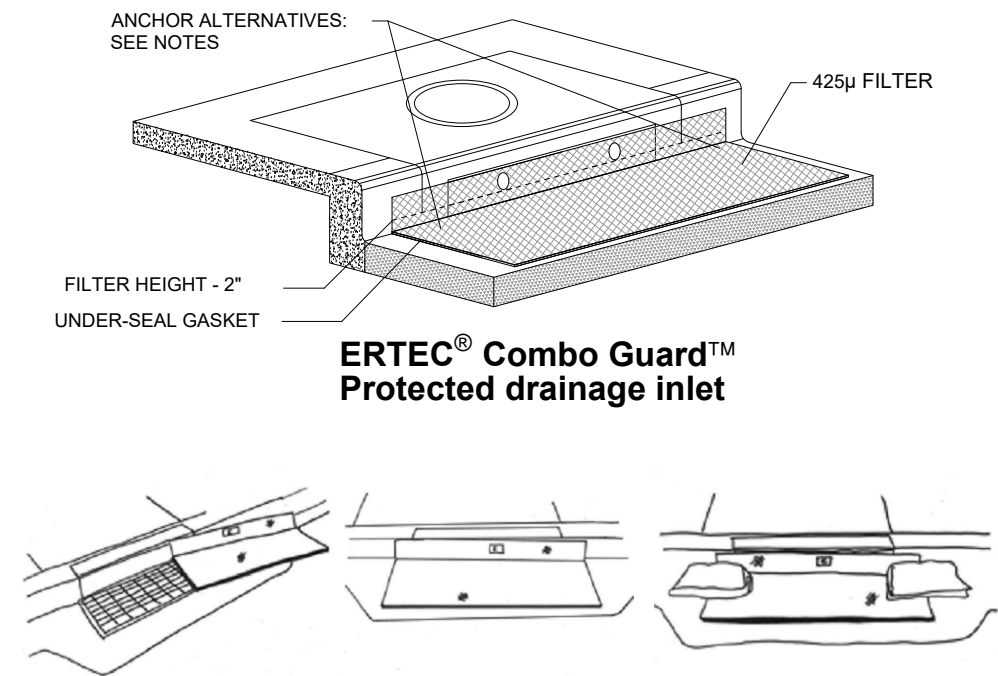

1A INLET PROTECTION - OPTION 1

Scale: NTS

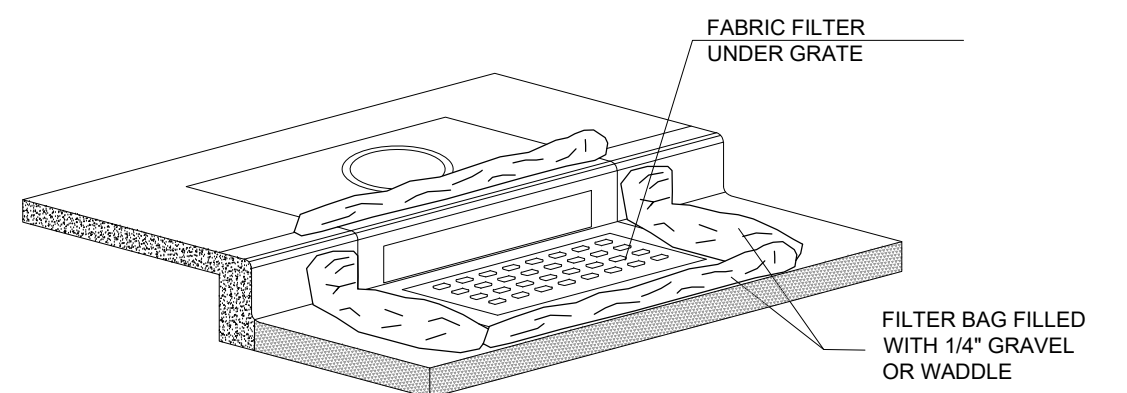

1B INLET PROTECTION - OPTION 2

Scale: NTS

2 SILT FENCE

Scale: NTS

DEVELOPER:

SOUTH WEBER, LLC
KEVIN SCHINDLER
25000 ASSEMBLY PARK DR.
WIXOM, MI 48393
(248) 787-4690

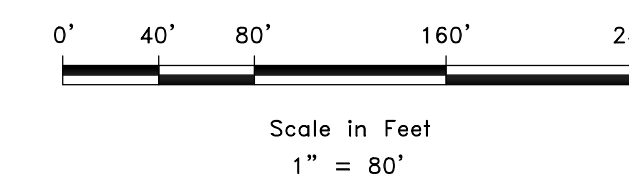

SCALE: 1" = 80'	DATE: 1/4/2023	DESIGN: WJS	DRAWN: WJS	CHECKED: TAY
REVISIONS	DATE	DESCRIPTION		

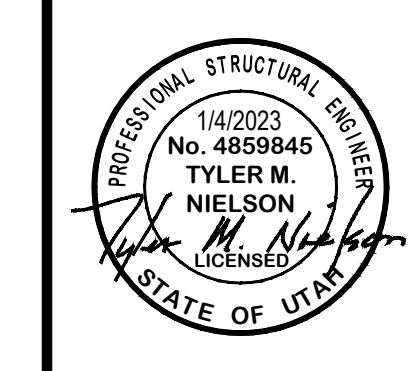

SWPPP
RV GENERAL
546 EAST OLD FORT ROAD
SOUTH WEBER CITY, DAVIS COUNTY, UTAH

GARDNER ENGINEERING
CIVIL - LAND PLANNING
MUNICIPAL - LAND SURVEYING
396 S CHAMBERLAIN ST., SUITE #5, OGDEN, UT 84405
P. 801.476.0202 F. 801.476.0066



CE1-02

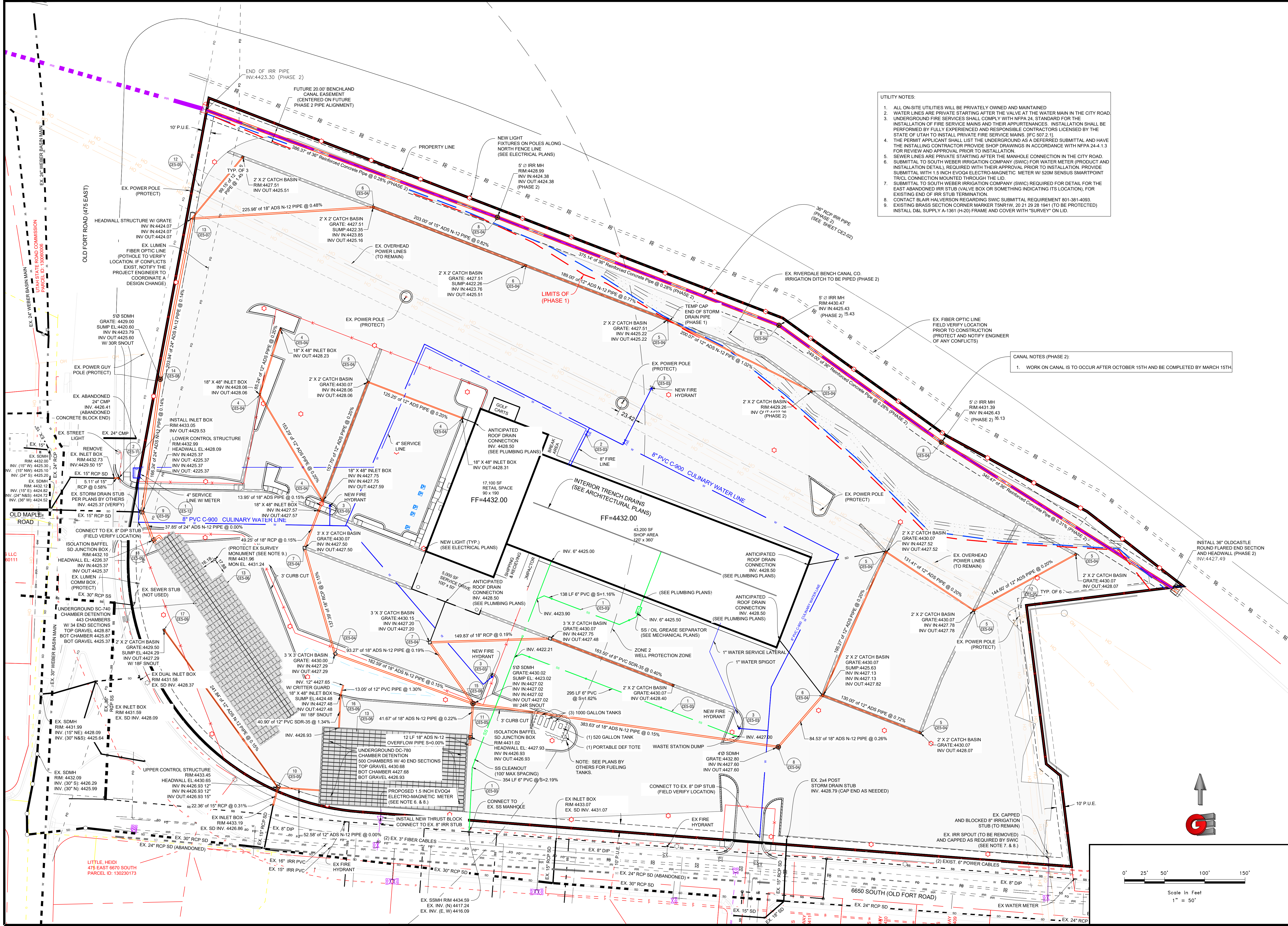

- UTILITY NOTES:
1. ALL ON-SITE UTILITIES WILL BE PRIVATELY OWNED AND MAINTAINED
 2. WATER LINES ARE PRIVATE STARTING AFTER THE VALVE AT THE WATER MAIN IN THE CITY ROAD
 3. UNDERGROUND FIRE SERVICES SHALL COMPLY WITH NFPA 24, STANDARD FOR THE INSTALLATION OF FIRE SERVICE MAINS AND THEIR APPURTENANCES. INSTALLATION SHALL BE PERFORMED BY FULLY EXPERIENCED AND RESPONSIBLE CONTRACTORS LICENSED BY THE STATE OF UTAH TO INSTALL PRIVATE FIRE SERVICE MAINS. (IPC 507.2.1)
 4. THE PERMIT APPLICANT SHALL LIST THE UNDERGROUND AS A DEFERRED SUBMITTAL AND HAVE THE INSTALLING CONTRACTOR PROVIDE SHOP DRAWINGS IN ACCORDANCE WITH NFPA 24.1.3 FOR REVIEW AND APPROVAL PRIOR TO INSTALLATION.
 5. SEWER LINES ARE PRIVATE STARTING AFTER THE MANHOLE CONNECTION IN THE CITY ROAD.
 6. SUBMITTAL TO SOUTH WEBER IRRIGATION COMPANY (SWIC) FOR WATER METER (PRODUCT AND INSTALLATION DETAIL), REQUIRED WITH THEIR APPROVAL PRIOR TO INSTALLATION. PROVIDE SUBMITTAL WITH 1.5 INCH EVOC4 ELECTRO-MAGNETIC METER W/ 520M SENSUS SMARTPOINT TRICL CONNECTION MOUNTED THROUGH THE LID.
 7. SUBMITTAL TO SOUTH WEBER IRRIGATION COMPANY (SWIC) REQUIRED FOR DETAIL FOR THE EAST ABANDONED IRR STUB (VALVE BOX OR SOMETHING INDICATING ITS LOCATION), FOR EXISTING END OF IRR STUB TERMINATION.
 8. CONTACT BLAIR HALVERSON REGARDING SWIC SUBMITTAL REQUIREMENT 801-381-4093.
 9. EXISTING BRASS SECTION CORNER MARKER TSN1W, 20 21 29 28 1941 (TO BE PROTECTED) INSTALL D&L SUPPLY A-1361 (H-20) FRAME AND COVER WITH "SURVEY" ON LID.

- CANAL NOTES (PHASE 2):
1. WORK ON CANAL IS TO OCCUR AFTER OCTOBER 15TH AND BE COMPLETED BY MARCH 15TH.

SCALE:	1" = 50'
DATE:	1/4/2023
DESIGN:	WJS
DRAWN:	WJS
CHECKED:	TAN

REVISIONS	DESCRIPTION

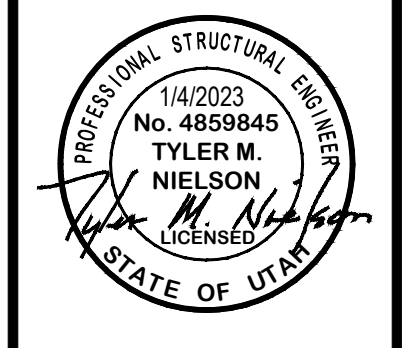

UTILITY PLAN
 RV GENERAL
 546 EAST OLD FORT ROAD
 SOUTH WEBER CITY, DAVIS COUNTY, UTAH

GARDNER ENGINEERING
 CIVIL - LAND PLANNING
 MUNICIPAL - LAND SURVEYING
 3965 CHAMBERS ST., SUITE #5, OGDEN, UT 84405
 P: 801.476.0202, F: 801.476.0066

CE2-01

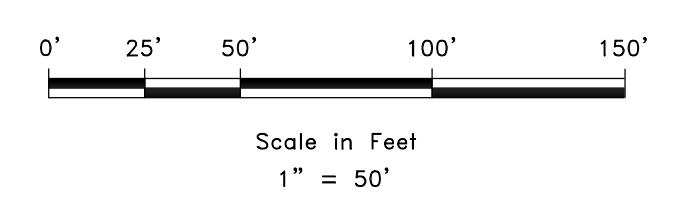

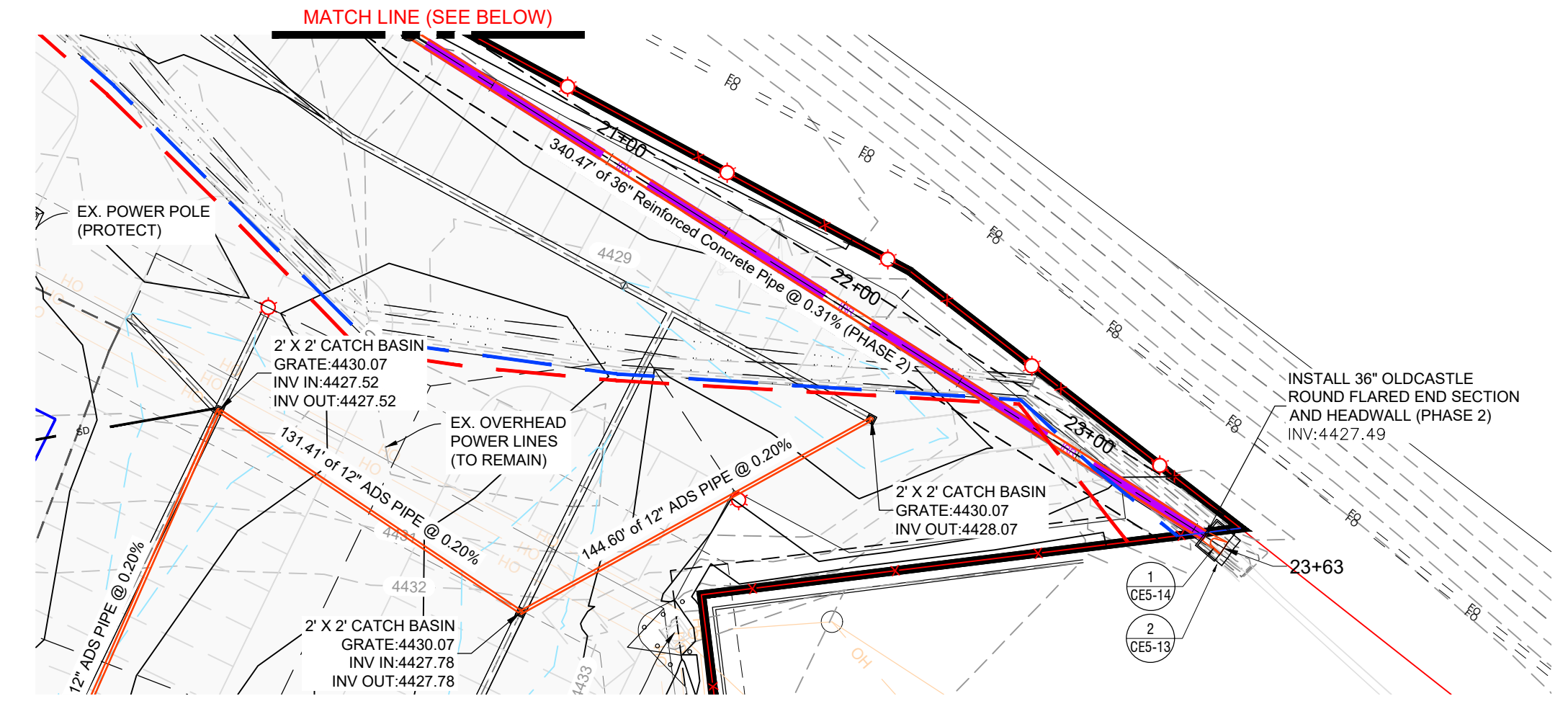
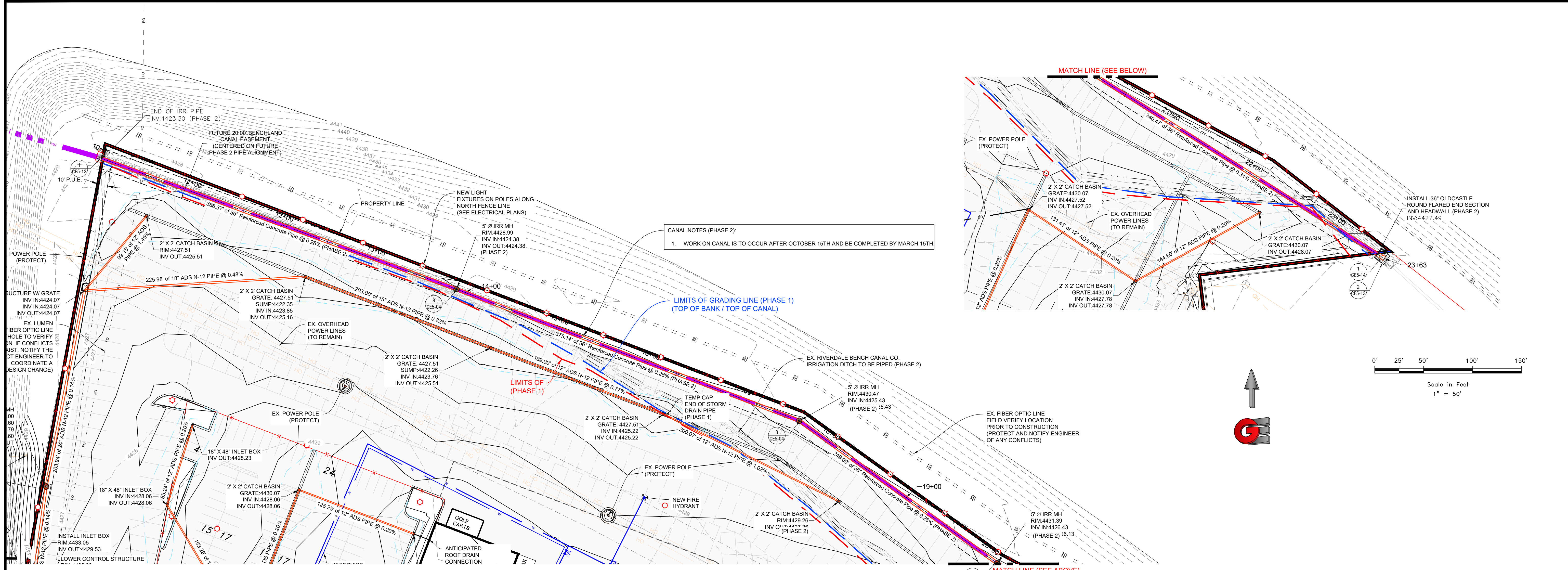

CANAL NOTES (PHASE 2):
 1. WORK ON CANAL IS TO OCCUR AFTER OCTOBER 15TH AND BE COMPLETED BY MARCH 15TH.

LIMITS OF GRADING LINE (PHASE 1)
 (TOP OF BANK / TOP OF CANAL)

LIMITS OF (PHASE 1)

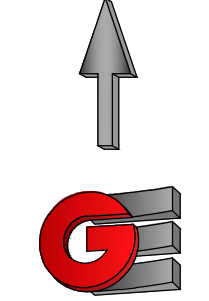
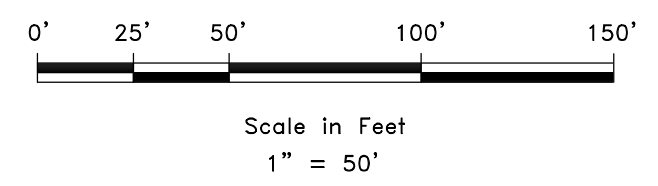

CANAL ALIGNMENT PROFILE

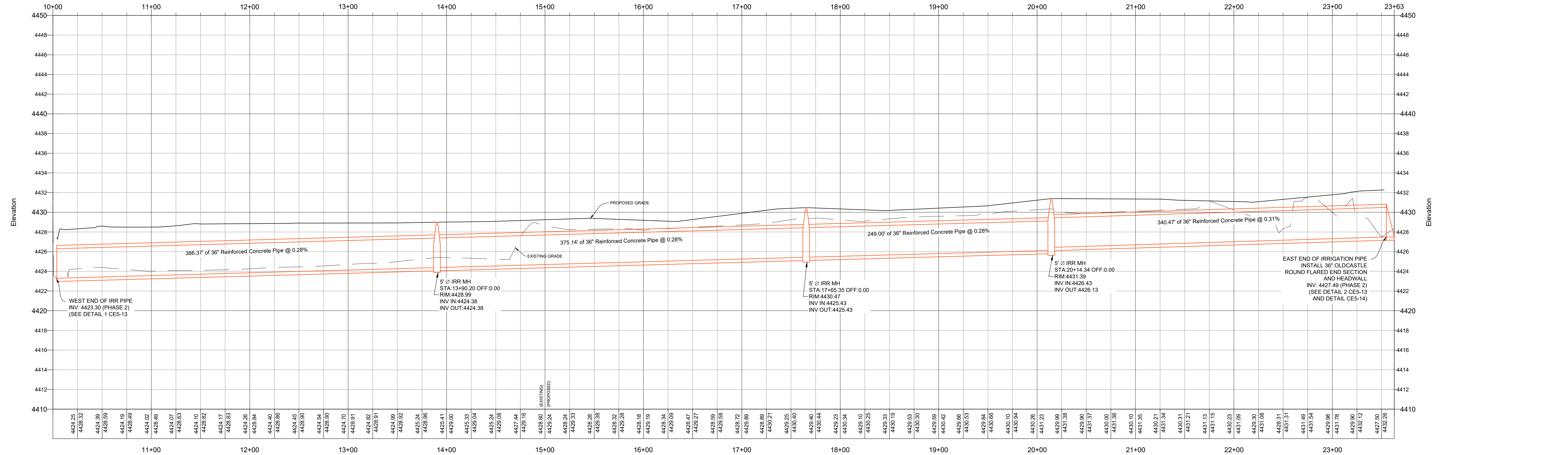

SCALE: 1" = 50'

REVISIONS	DATE	DESCRIPTION

DATE: 1/4/2023
 DESIGN: WJS
 DRAWN: WJS
 CHECKED: TAN

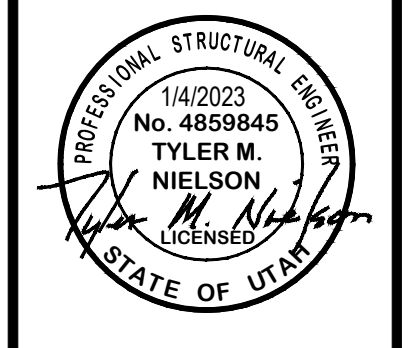

IRRIGATION DITCH PROFILE
 BY GENERAL
 546 EAST OLD FORT ROAD
 SOUTH WEBER CITY, DAVIS COUNTY, UTAH

GARDNER ENGINEERING
 CIVIL - LAND PLANNING
 MUNICIPAL - LAND SURVEYING
 985 S CHAMBERLAIN ST., SUITE #5, OGDEN, UT 84405
 P. 801.476.0202 F. 801.476.0066



CE2-02

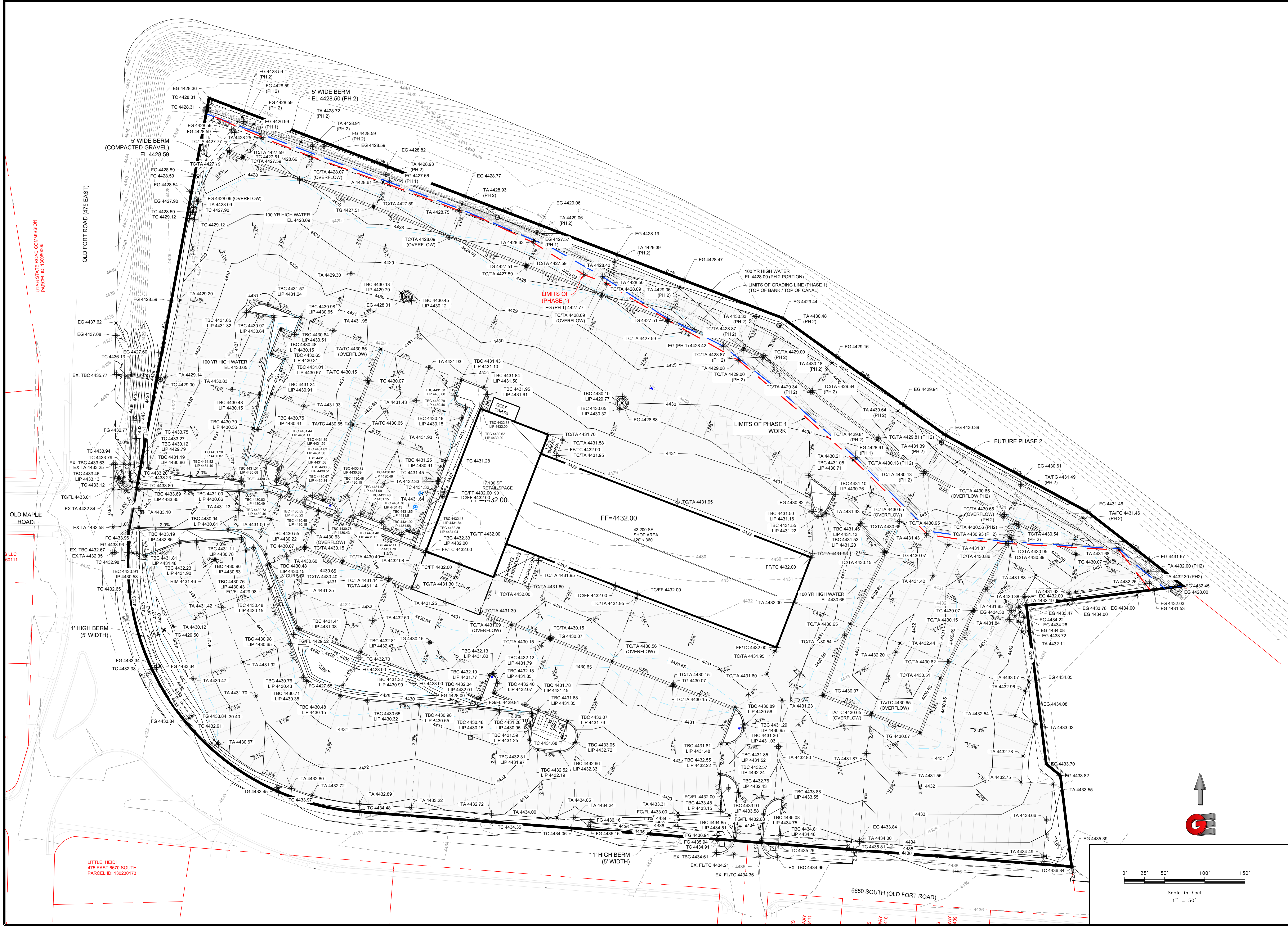

SCALE: 1" = 50'

DATE	1/4/2023
DESIGN	WJS
DRAWN	WJS
CHECKED	TAN

REVISIONS

DATE	DESCRIPTION

DWG: R.V. 1932 - SOUTH WEBER LLC 2021 - GENERAL BY SOUTH WEBER DESIGN, DWG GRADING PLAN

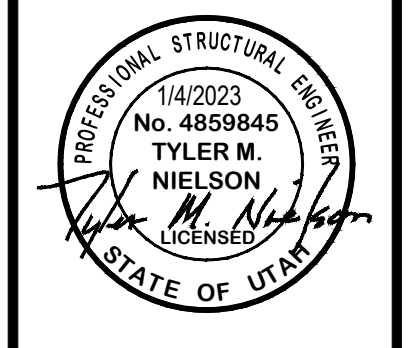

GRADING PLAN
RY GENERAL
546 EAST OLD FORT ROAD
SOUTH WEBER CITY, DAVIS COUNTY, UTAH

GARDNER ENGINEERING
 CIVIL - LAND PLANNING
 MUNICIPAL - LAND SURVEYING
 985 S CHAMBERLAIN ST., SUITE #5, OGDEN, UT 84405
 P: 801.476.0202, F: 801.476.0066

CE3-01

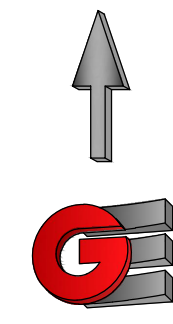
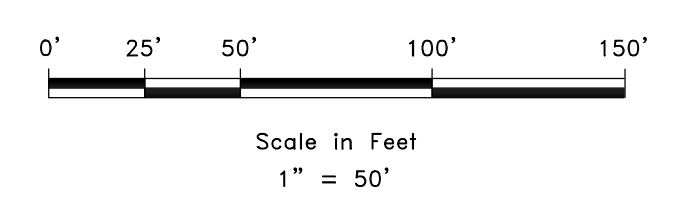

UTAH STATE ROAD COMMISSION
 PARCEL ID: 13006006

SLLC
 90111

LITTLE, HEIDI
 475 EAST 6670 SOUTH
 PARCEL ID: 130230173

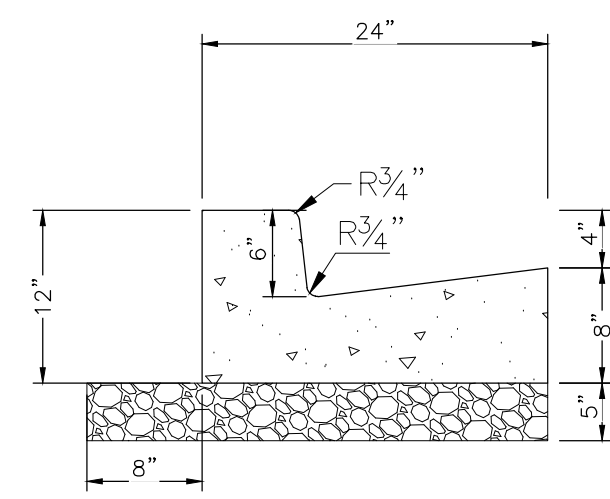

PAVEMENT NOTE:

- PAVEMENT DESIGNED BY GEOTECH ENGINEER ACCORDING TO AASHTO 1993 AND COMPLIES WITH AASHTO 1993.

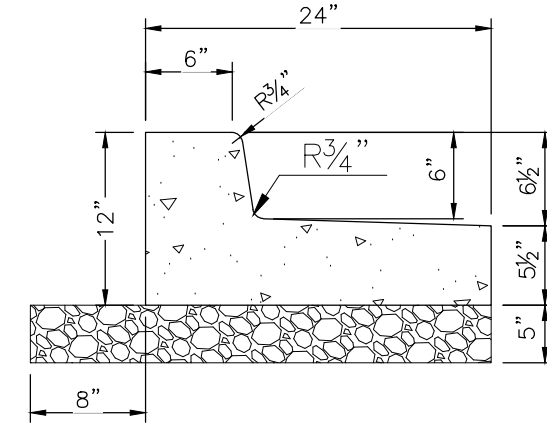

1 24\"/>

2 24\"/>

CURB AND GUTTER CONSTRUCTION NOTES:

- OPEN FACE GUTTER SHALL BE CONSTRUCTED WHERE DRAINAGE IS DIRECTED AWAY FROM CURB.
- OPEN FACE CURB & GUTTER LOCATIONS ARE INDICATED BY HATCHING AND NOTES ON THE GRADING PLAN.
- IT IS THE RESPONSIBILITY OF THE CONTRACTOR/SURVEYOR TO ADJUST TOP OF CURB GRADES AT THE TIME OF CONSTRUCTION STAKING.
- REFER TO THE TYPICAL DETAILS FOR STANDARD (CLOSED) AND OPEN FACE CURB AND GUTTER FOR DIMENSIONS.
- TRANSITIONS BETWEEN OPEN FACE AND STANDARD (CLOSED) CURB AND GUTTER ARE TO BE SMOOTH. HAND FORM THESE AREAS IF NECESSARY.
- CRUSHED GRAVEL BASE COURSE SHALL BE PLACED UNDER CURB AT MINIMUM DEPTH SHOWN AND EXTENDED BEYOND THE TOP BACK OF CURB AS SHOWN.
- PROVIDE PROPERLY PREPARED SUBGRADE A MINIMUM OF 18 INCHES BEYOND THE TBC (OR AS DIRECTED BY GEOTECH REPORT) WHICH EVER IS GREATER.
- THE ABOVE CURB AND GUTTER DETAILS ARE FOR ON-SITE (PRIVATE) CURB AND GUTTER ONLY. CURB AND GUTTER PLACED WITHIN THE PUBLIC RIGHT OF WAY IS TO FOLLOW CITY STANDARDS.

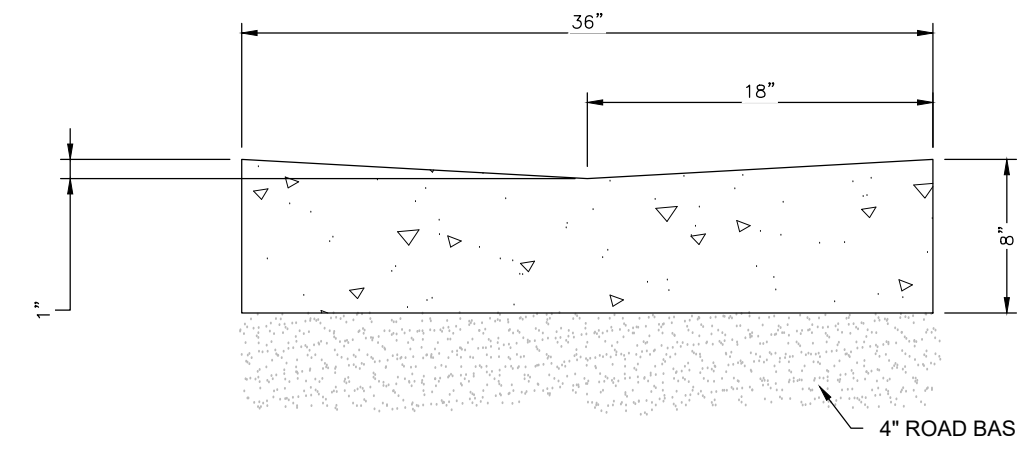

WATERWAY NOTE:

- THE ABOVE WATERWAY DETAIL IS FOR ON-SITE (PRIVATE) USE ONLY. WATERWAYS ARE NOT ALLOWED WITHIN THE CITY RIGHT OF WAY.

PAVEMENT NOTE:

- PAVEMENT DESIGNED BY GEOTECH ENGINEER ACCORDING TO AASHTO 1993 AND COMPLIES WITH AASHTO 1993.

3 CONCRETE WATERWAY (PRIVATE)
Scale: NTS

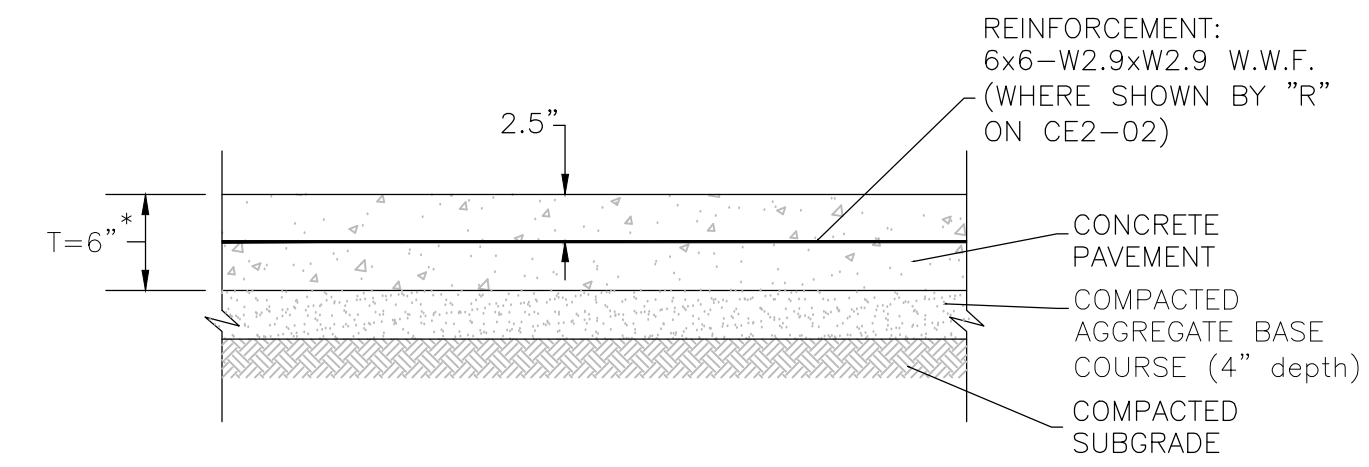
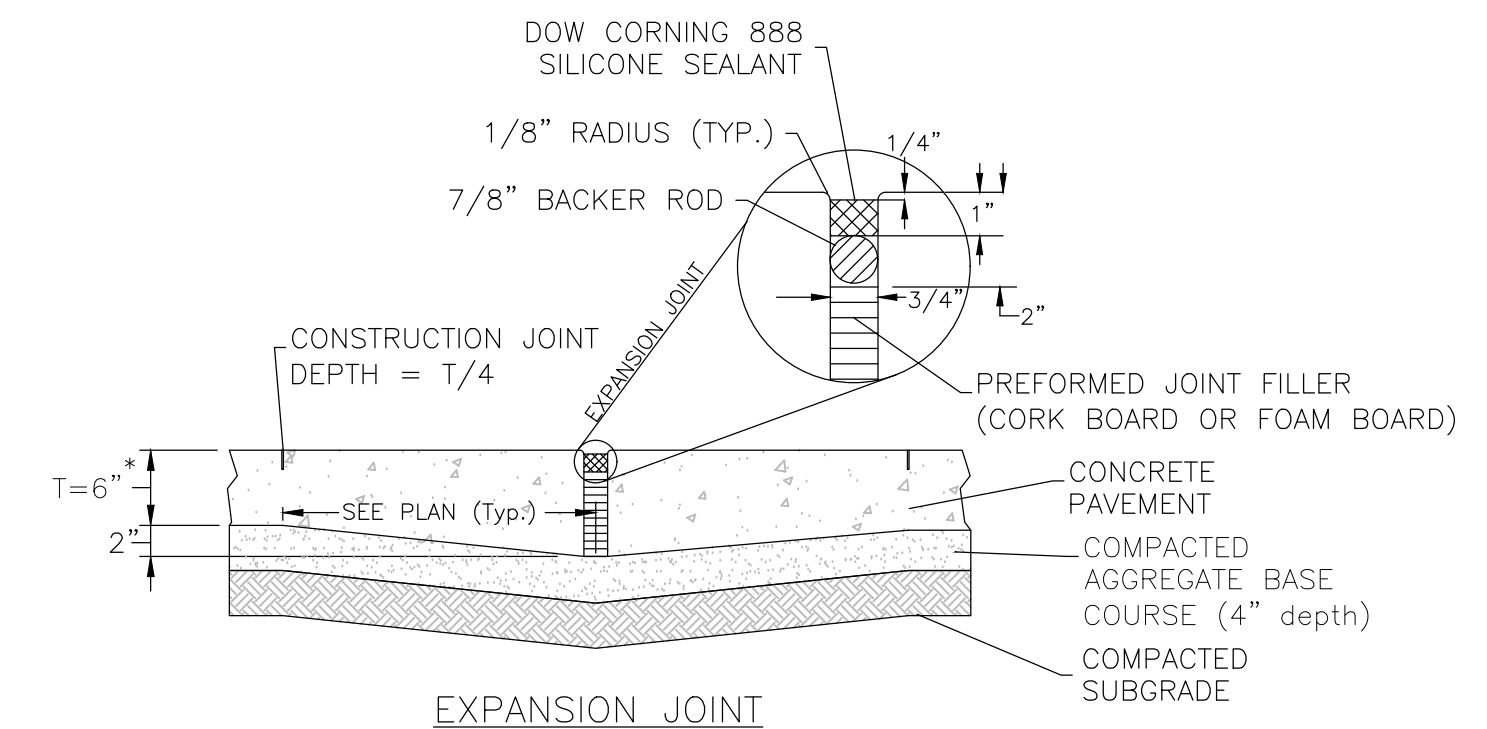

- PAVEMENT NOTE:**
- PAVEMENT DESIGNED BY GEOTECH ENGINEER ACCORDING TO AASHTO 1993 AND COMPLIES WITH AASHTO 1993.

REFER TO GEOTECH REPORT

5 HEAVY DUTY ASPHALT PAVING SECTION
Scale: (NOT TO SCALE)

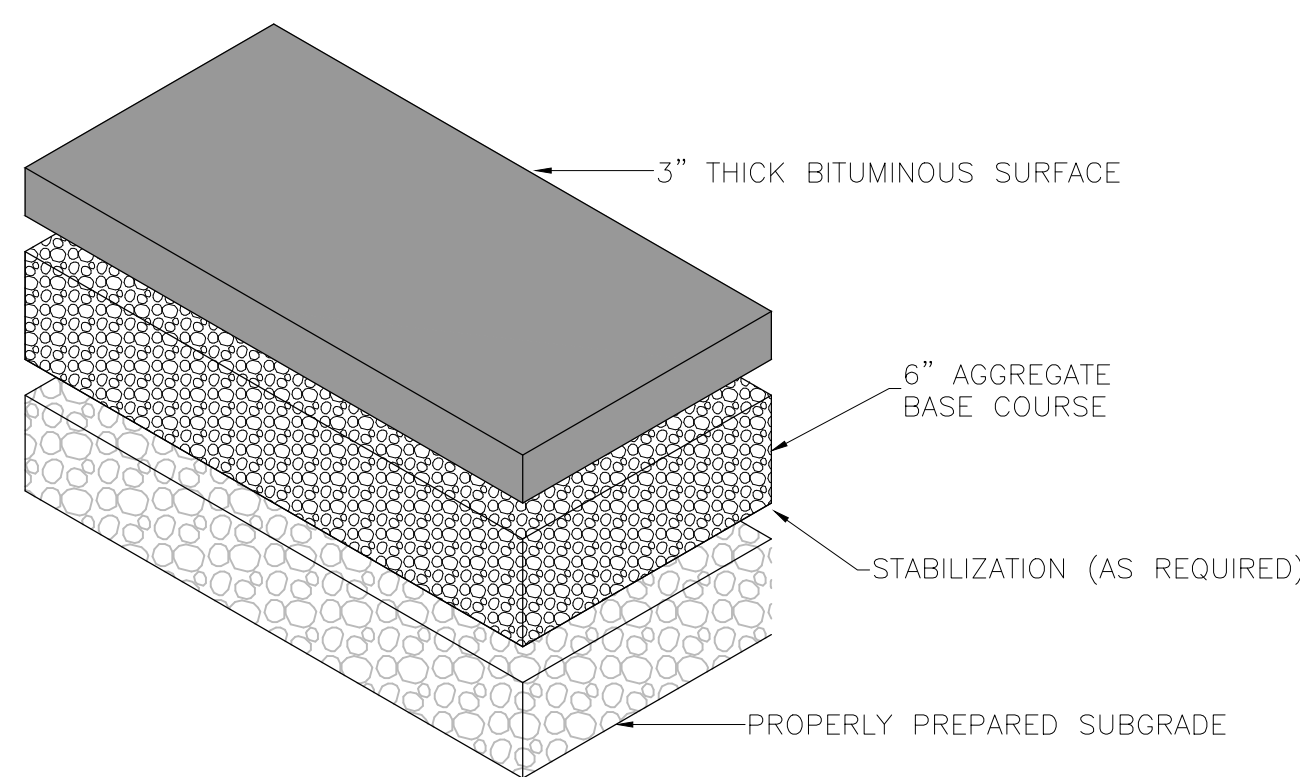

PAVEMENT NOTE:

- PAVEMENT DESIGNED BY GEOTECH ENGINEER ACCORDING TO AASHTO 1993 AND COMPLIES WITH AASHTO 1993.

REFER TO GEOTECH REPORT

6 LIGHT DUTY ASPHALT PAVING SECTION
Scale: (NOT TO SCALE)

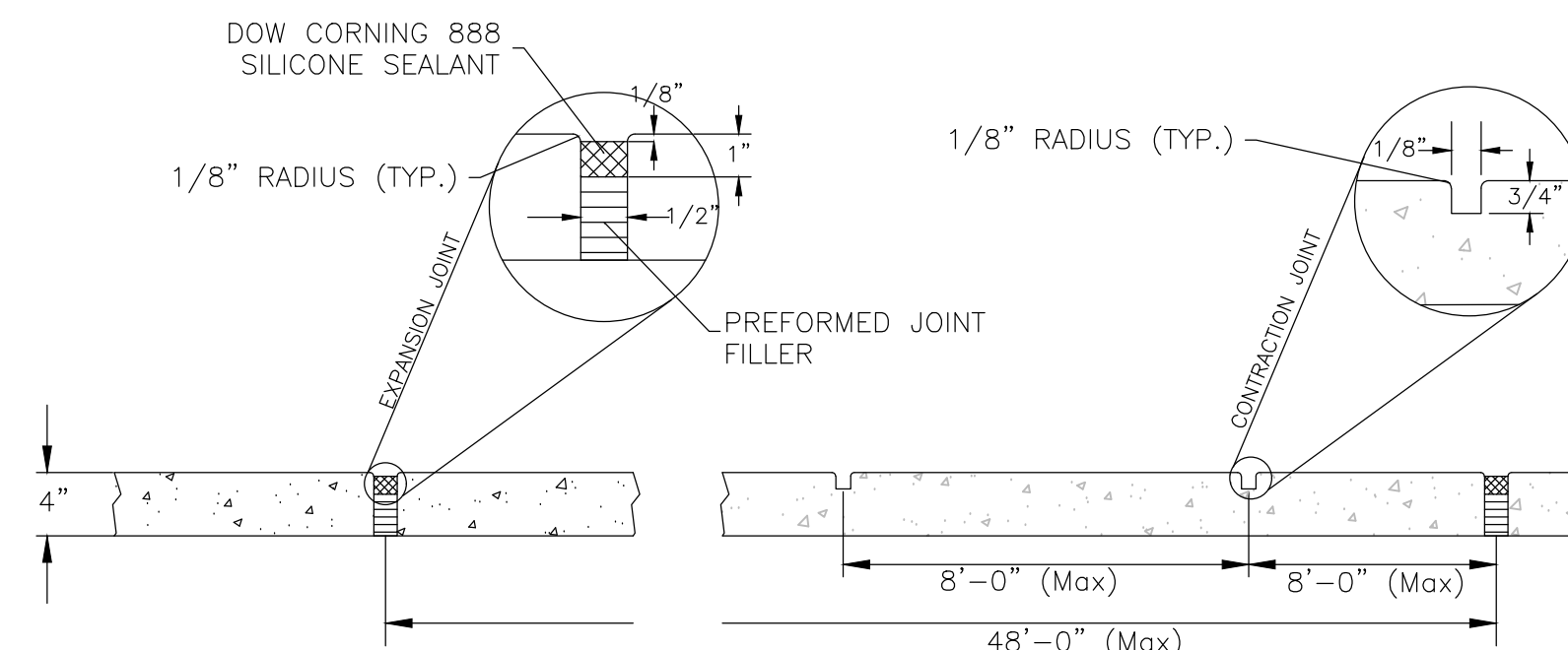

SIDEWALK NOTE:

- THE ABOVE SIDEWALK DETAIL IS FOR ON-SITE (PRIVATE) USE ONLY. REFER TO PROVIDED CITY DETAIL FOR WORK WITHIN RIGHT OF WAY ON SHEET CE5-10.

7 TYPICAL CONCRETE SIDEWALK DETAIL (PRIVATE)
Scale: (NOT TO SCALE)

4 STANDARD CONCRETE PAVEMENT
Scale: (NOT TO SCALE)

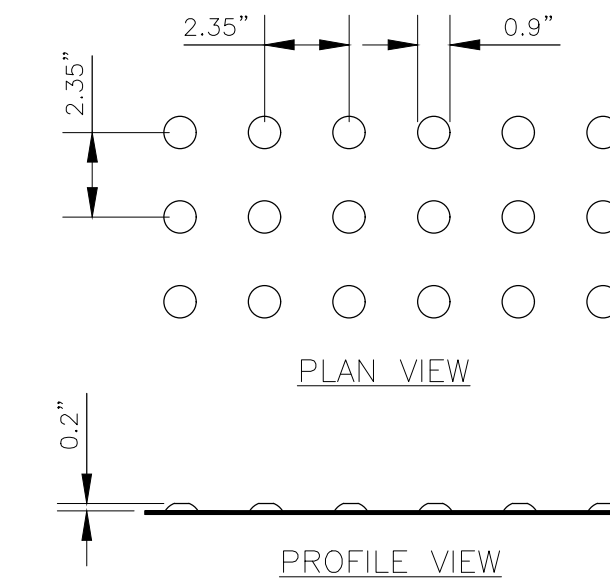

- NOTE:**
TRUNCATED DOME PATTERN SHALL:
- SHALL BE LOCATED 6 TO 8 INCHES FROM CURB OR HAZARD
 - EXTEND THE FULL WIDTH OF THE RAMP
 - BE IN-LINE WITH DIRECTION OF TRAVEL
 - NOT EXCEED A 1:12 SLOPE

TYPICAL TRUNCATED DOME DETAIL (PRIVATE)
Scale: NTS

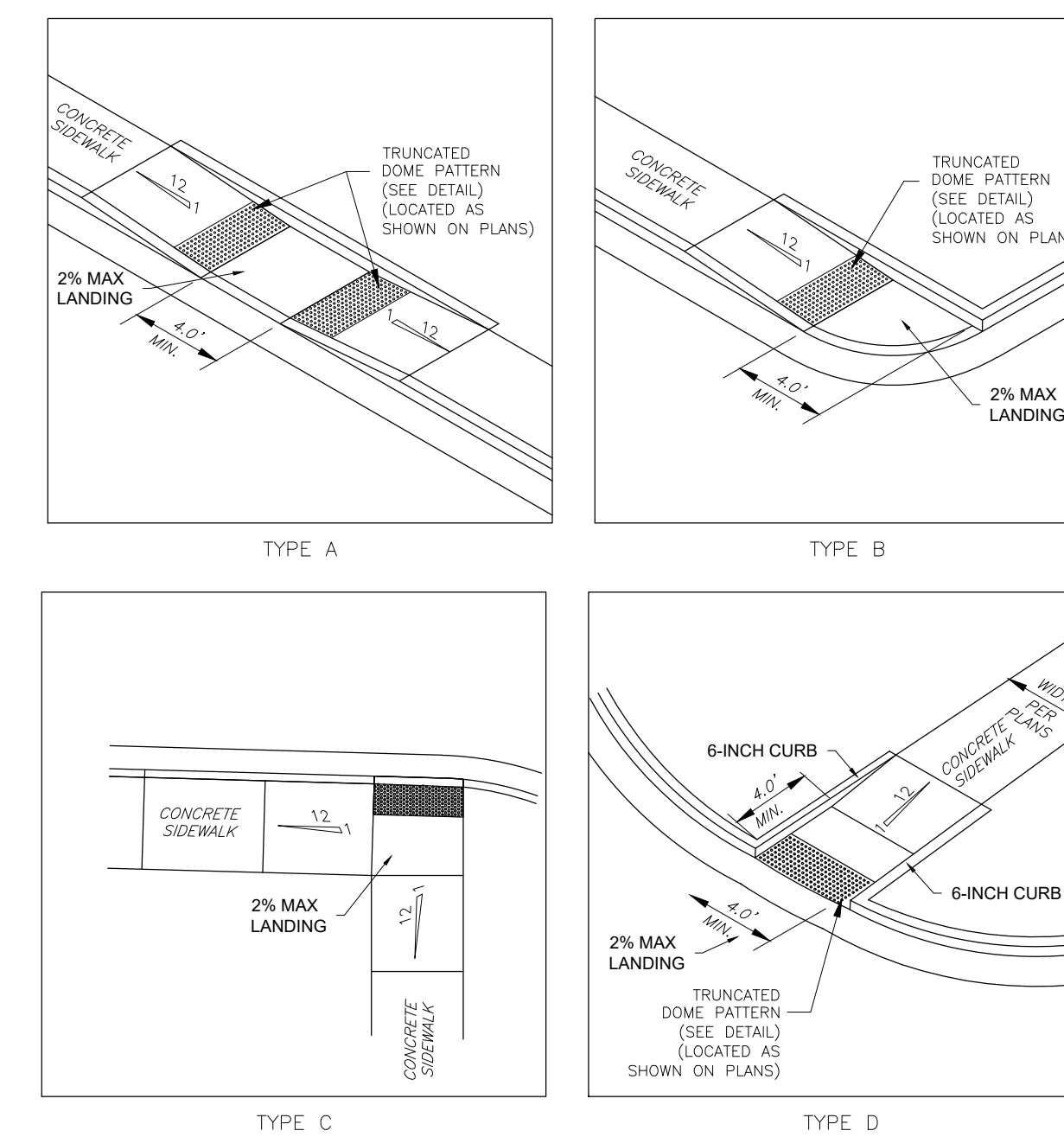

CURB RAMP TO MEET CITY STANDARDS

- NOTES:**
- SEE APWA PLAN NO. 236 FOR ADA RAMP REQUIREMENTS AND APWA PLAN NO. 238 FOR TRUNCATED DOME REQUIREMENTS.
 - CURB SHOULD HAVE A TEXTURED NON-SLIP SURFACE AS BROOM FINISH CONCRETE.

8 ADA RAMP DETAIL (PRIVATE)
Scale: (NOT TO SCALE)

ADA RAMP NOTE:

- THE ABOVE ADA RAMP DETAIL IS FOR ON-SITE (PRIVATE) USE ONLY. REFER TO PROVIDED CITY DETAIL ON SHEET CE5-10 FOR TRUNCATED DOMES AND FOR ADA RAMPS WITHIN CITY RIGHT OF WAY.

SCALE: 1"=50'	DATE: 1/4/2023	DESIGN: WJS	DRAWN: WJS	CHECKED: TMN
REVISIONS	DESCRIPTION	DATE		

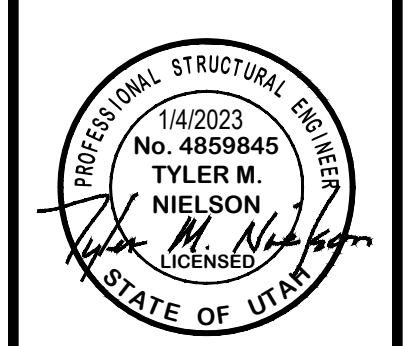

CIVIL SITE DETAILS
 RV GENERAL
 546 EAST OLD FORT ROAD
 SOUTH WEBER CITY, DAVIS COUNTY, UTAH



CE5-01

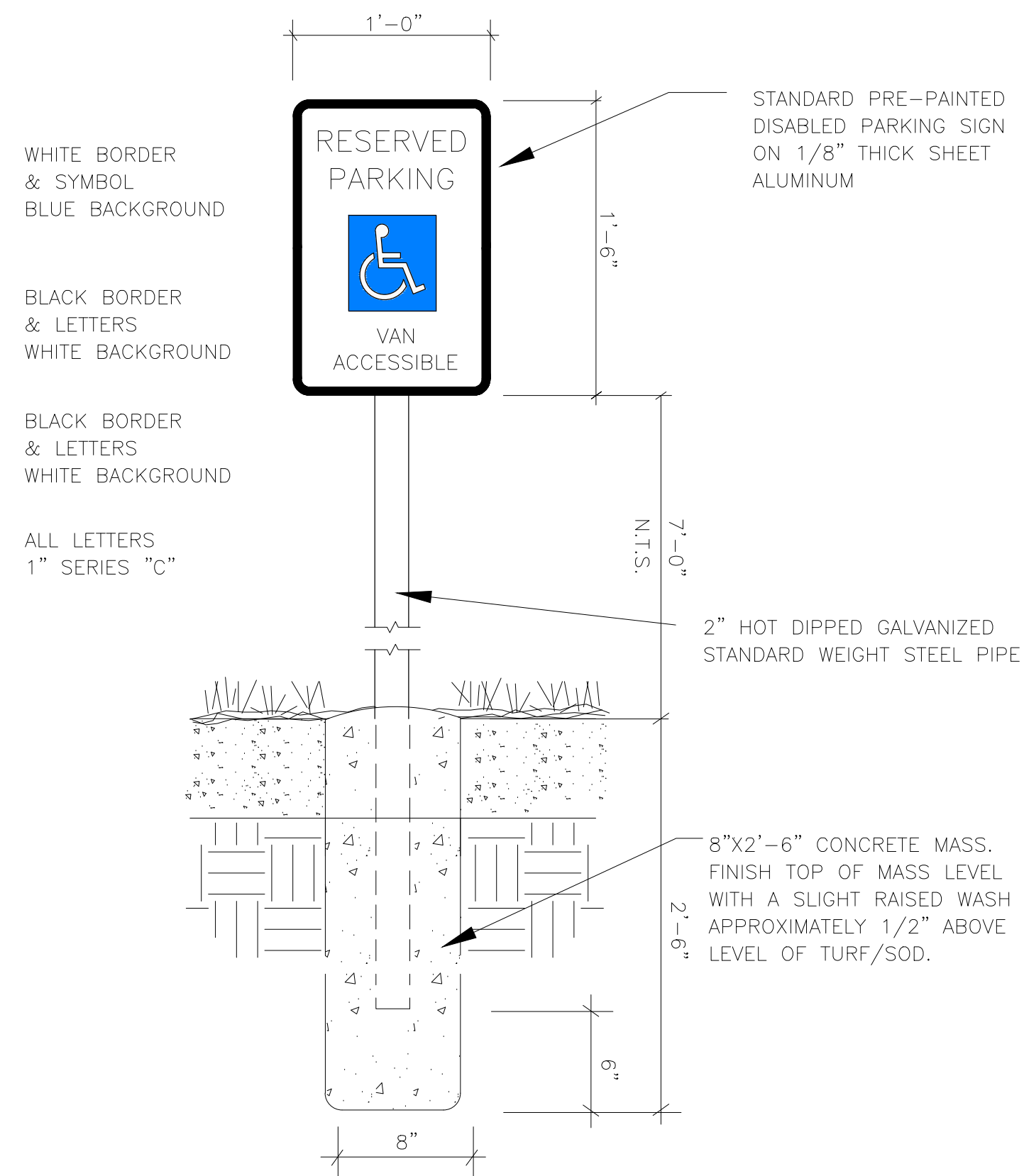

9 VAN ACCESSIBLE ADA PARKING SIGN DETAIL
Scale: (NOT TO SCALE)

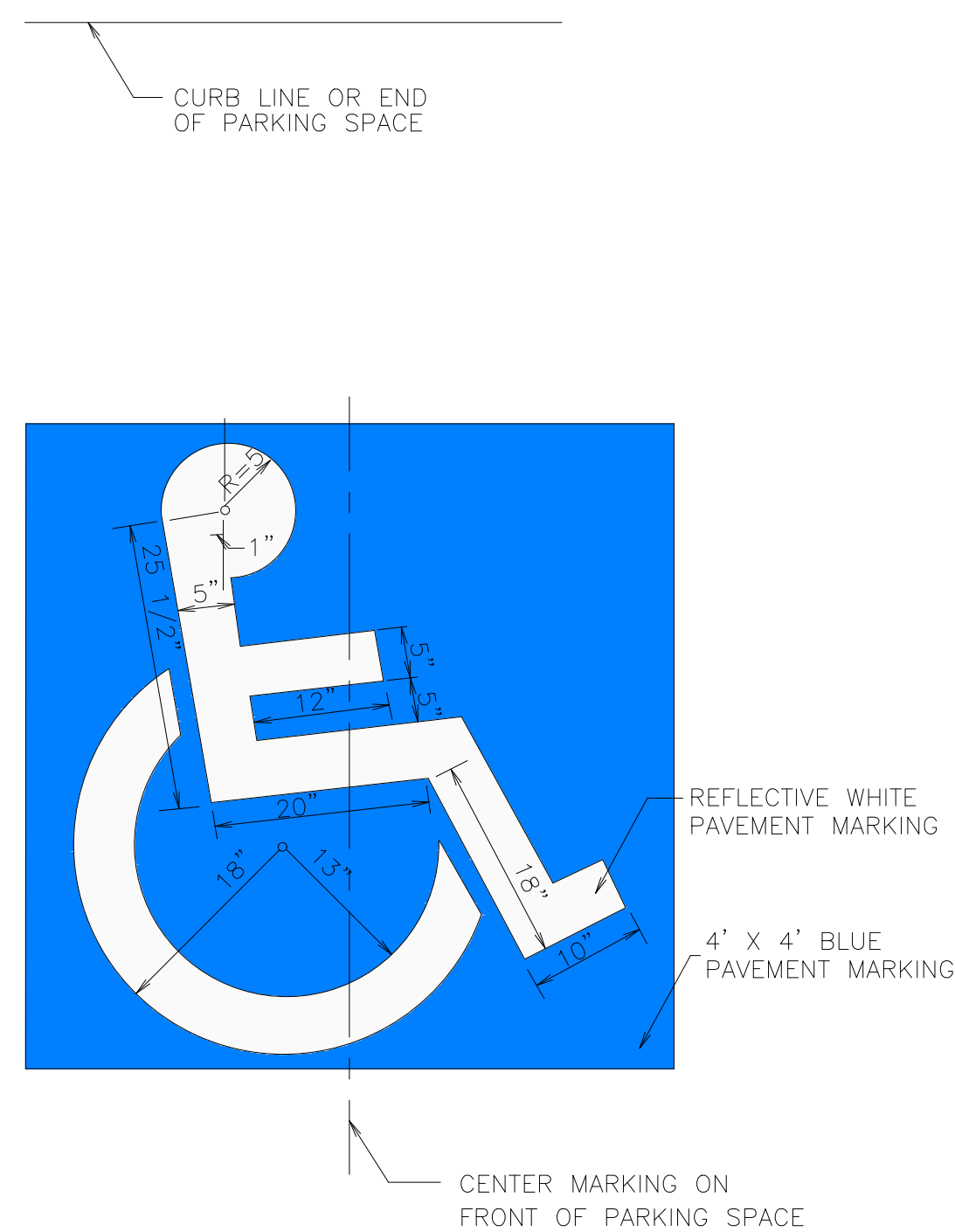

10 ADA PARKING SYMBOL
Scale: (NOT TO SCALE)

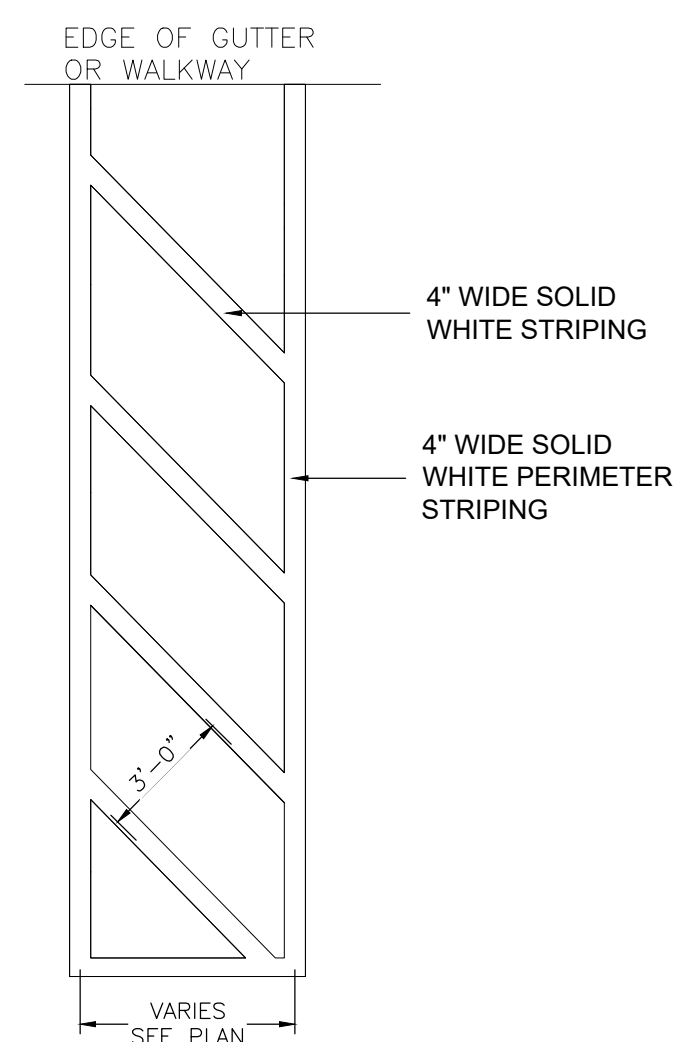

11 NO PARKING STRIPING
Scale: (NOT TO SCALE)

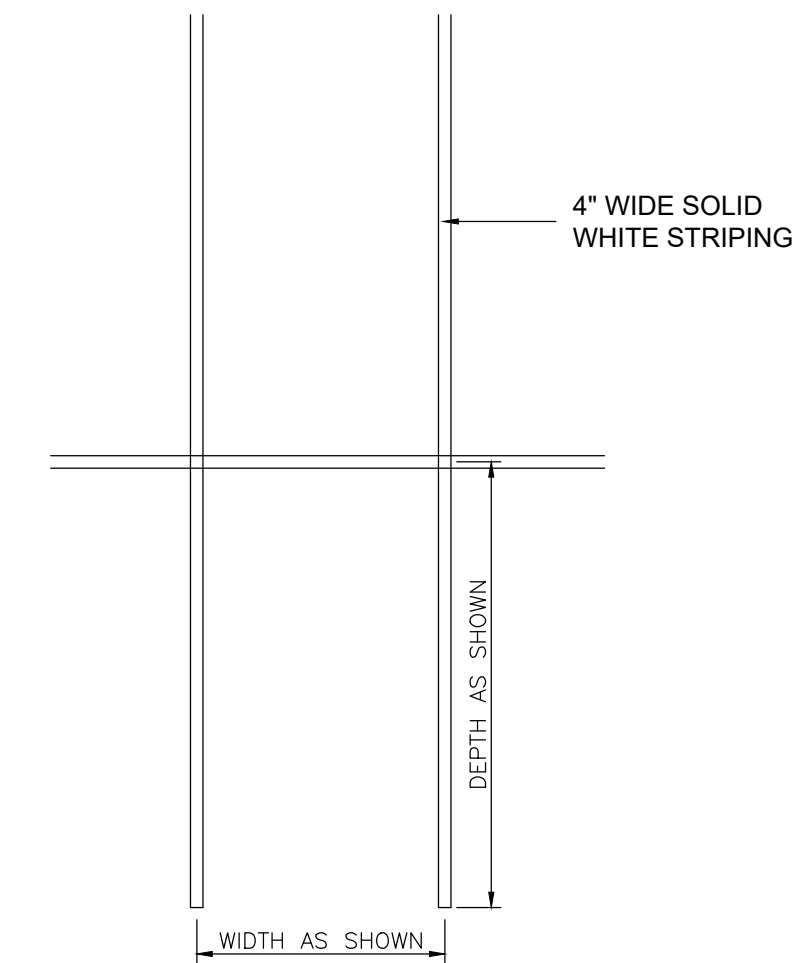

12 PARKING STRIPING DETAIL
Scale: (NOT TO SCALE)

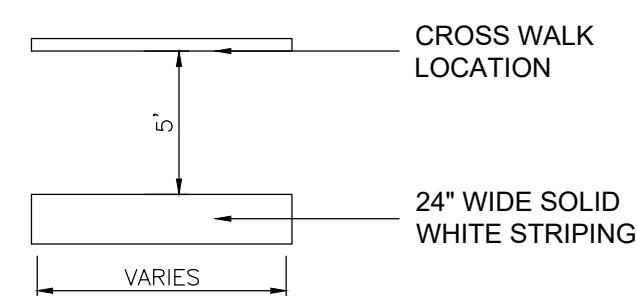

13 STOP BAR STRIPING
Scale: (NOT TO SCALE)

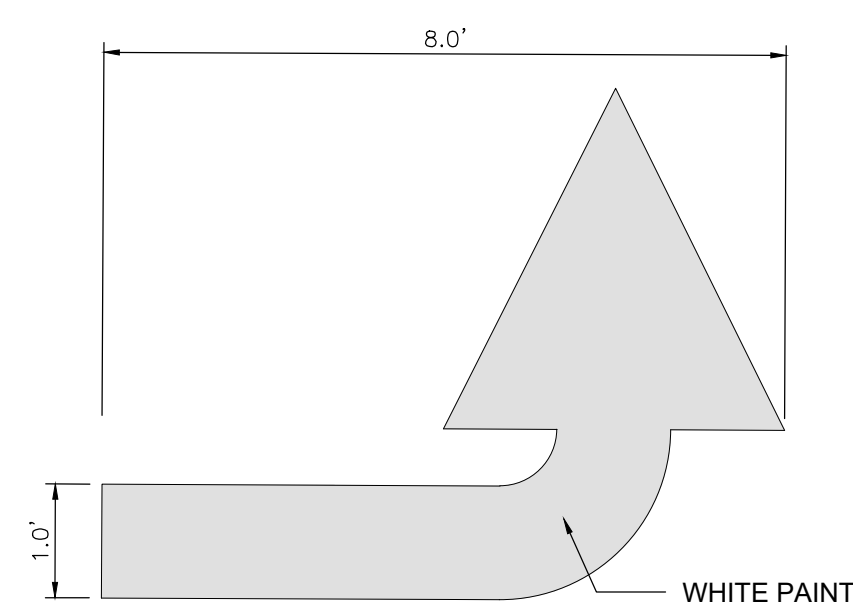

14 TURN ARROW MARKING
Scale: (NOT TO SCALE)

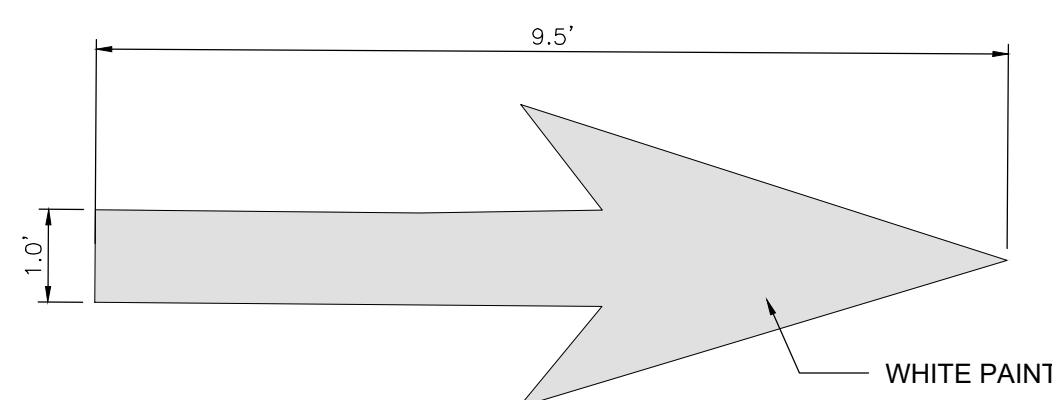

15 THROUGH LANE ARROW MARKING
Scale: (NOT TO SCALE)

CHAIN LINK FENCE NOTES:

- GENERAL
 - A. ADDITIONAL CHAIN LINK FENCE REQUIREMENTS ARE SPECIFIED IN APWA SECTION 32.31.13.
- PRODUCTS
 - A. TENSION WIRE: ZINC COATED, GALVANIZED, NO. 7 GAGE SPRING COIL STEEL.
 - B. POSTS: SCHEDULE 40 HOT DIPPED ZINC COATED STEEL PIPE, ASTM A120.
 - C. CONCRETE: CLASS 4000, APWA SECTION 03.30.04.
- EXECUTION
 - A. FENCE FABRIC: 6 FEET HIGH BLACK VINYL COATED CHAINLINK.
 - B. TENSION WIRE: SET WIRE AT 1-INCH OVER NATURAL GROUND OR 6-INCHES OVER CONCRETE STRUCTURES.
 - C. POST SPACING: LOCATE POSTS AT EQUAL SPACING FOR EACH SEGMENT WITH MAXIMUM SPACING SPECIFIED IN STANDARD SPECIFICATIONS.
 - D. BARB WIRE ARM: FACE ARM TOWARDS EXTERIOR OF FENCED AREA.
 - E. CONCRETE PLACEMENT: APWA SECTION 03.30.10. PROVIDE 1/2-INCH RADIUS EDGES. APPLY A BROOM FINISH. APPLY A CURING AGENT.

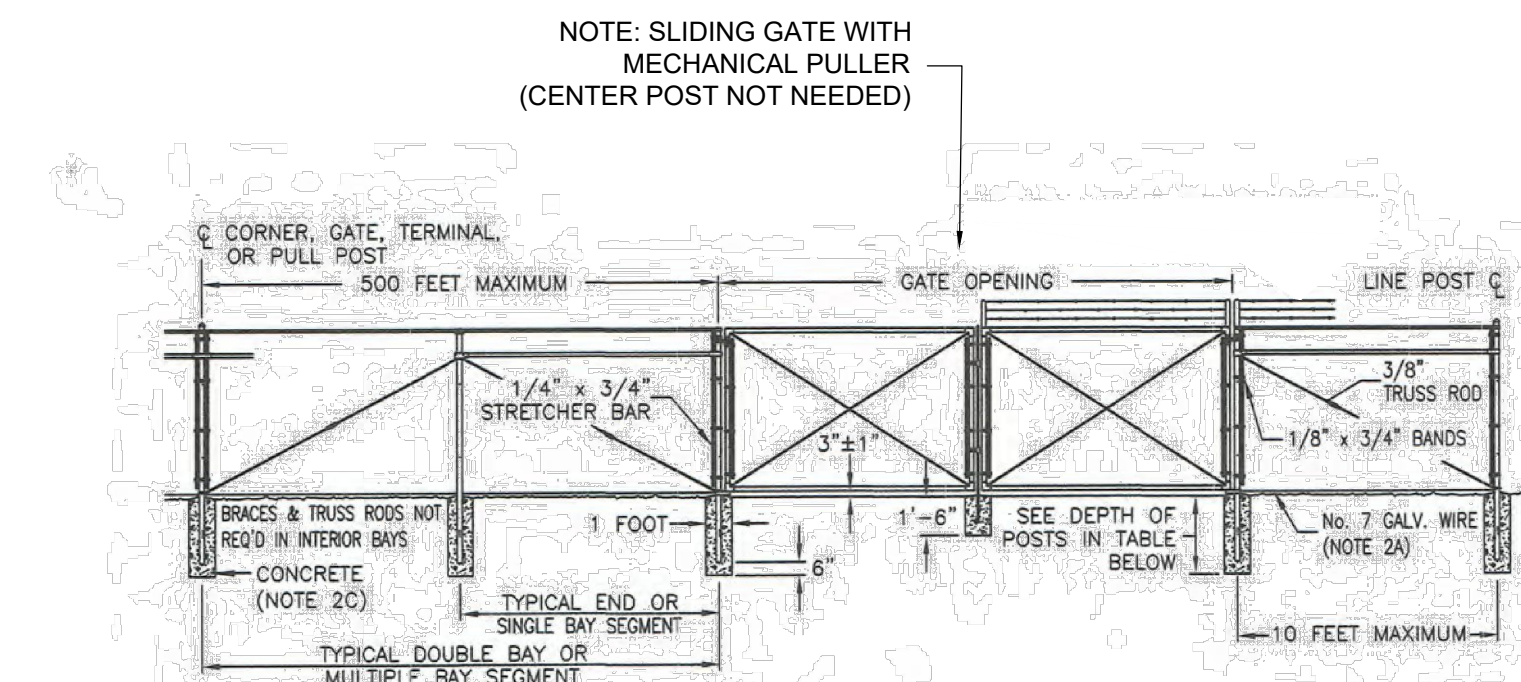
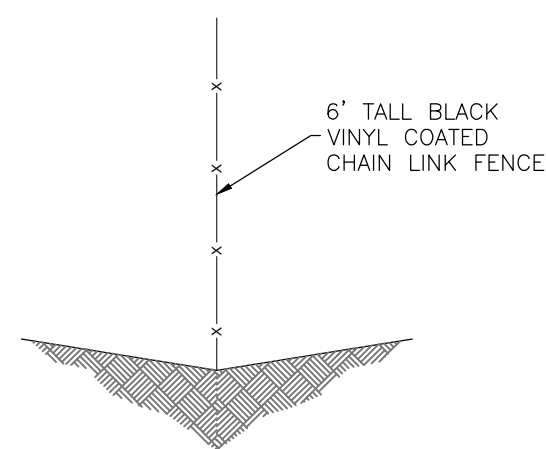

FENCE

HEIGHT OF FABRIC	DEPTH OF POSTS	LENGTH OF END OF CORNER OR PULL POST	LENGTH OF LINE POST	MINIMUM DIAMETER
7'	3"	10'	9'-8"	2 1/2"
6'	3"	9'	8'-8"	2 1/2"
5'	3"	8'	7'-8"	2"
4'	2"	6'	5'-8"	1 1/2"

HEIGHT	FRAME	GATE OPENING	POST
UNDER	1 1/2"	SINGLE TO 6" OR DOUBLE TO 12"	2"
6 FEET	1 1/2"	SINGLE OVER 6" TO 8" OR DOUBLE OVER 12" TO 16"	2 1/2"
6 FEET	1 1/2"	SINGLE OVER 8" TO 12" OR DOUBLE OVER 16" TO 24"	3 1/2"
6 FEET	1 1/2"	SINGLE TO 6" OR DOUBLE TO 12"	2 1/2"
6 FEET	1 1/2"	SINGLE OVER 6" TO 13" OR DOUBLE OVER 12" TO 26"	3 1/2"
AND OVER	1 1/2"	SINGLE OVER 13" TO 18" OR DOUBLE OVER 26" TO 36"	6"
		SINGLE OVER 18" OR DOUBLE OVER 36"	8"

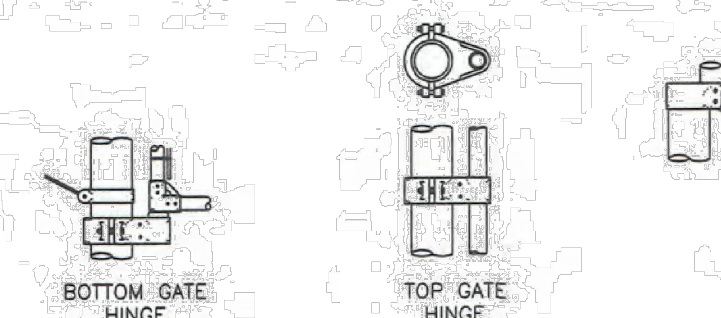

DETAILS

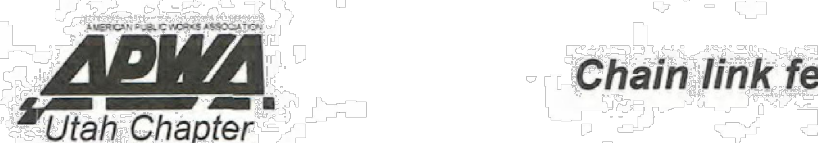

16 CHAIN LINK SECURITY FENCE
Scale: (NOT TO SCALE)

SCALE: 1"=50'

DATE: 1/4/2023

DESIGN: W.J.S.

DRAWN: W.J.S.

CHECKED: T.M.

REVISIONS

DATE	DESCRIPTION

PROFESSIONAL STRUCTURAL ENGINEER

1/4/2023

No. 4859845

TYLER M. NIELSON

LICENSED

STATE OF UTAH

CIVIL SITE DETAILS

RV GENERAL

546 EAST OLD FORT ROAD

SOUTH WEBER CITY, DAVIS COUNTY, UTAH

GARDNER ENGINEERING

CIVIL - LAND PLANNING

MUNICIPAL - LAND SURVEYING

5150 SOUTH 375 EAST OGDEN, UT

OFFICE: 801-476-0202 FAX: 801-476-0066

Plan 831

April 1997

CE5-02

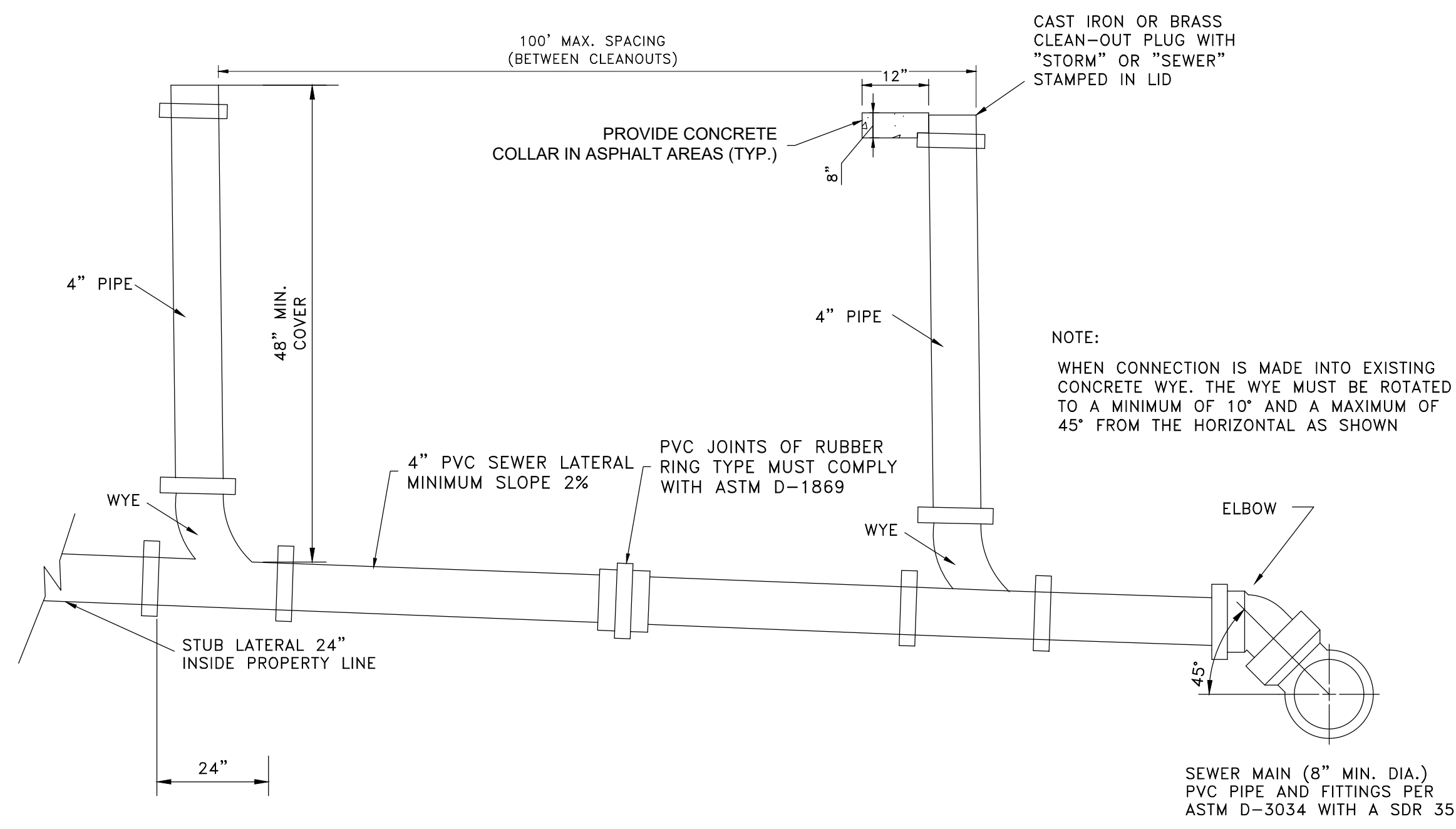

1 TYPICAL SANITARY SEWER OR STORM DRAIN LATERAL CLEANOUT CONNECTION
Scale: (NOT TO SCALE)

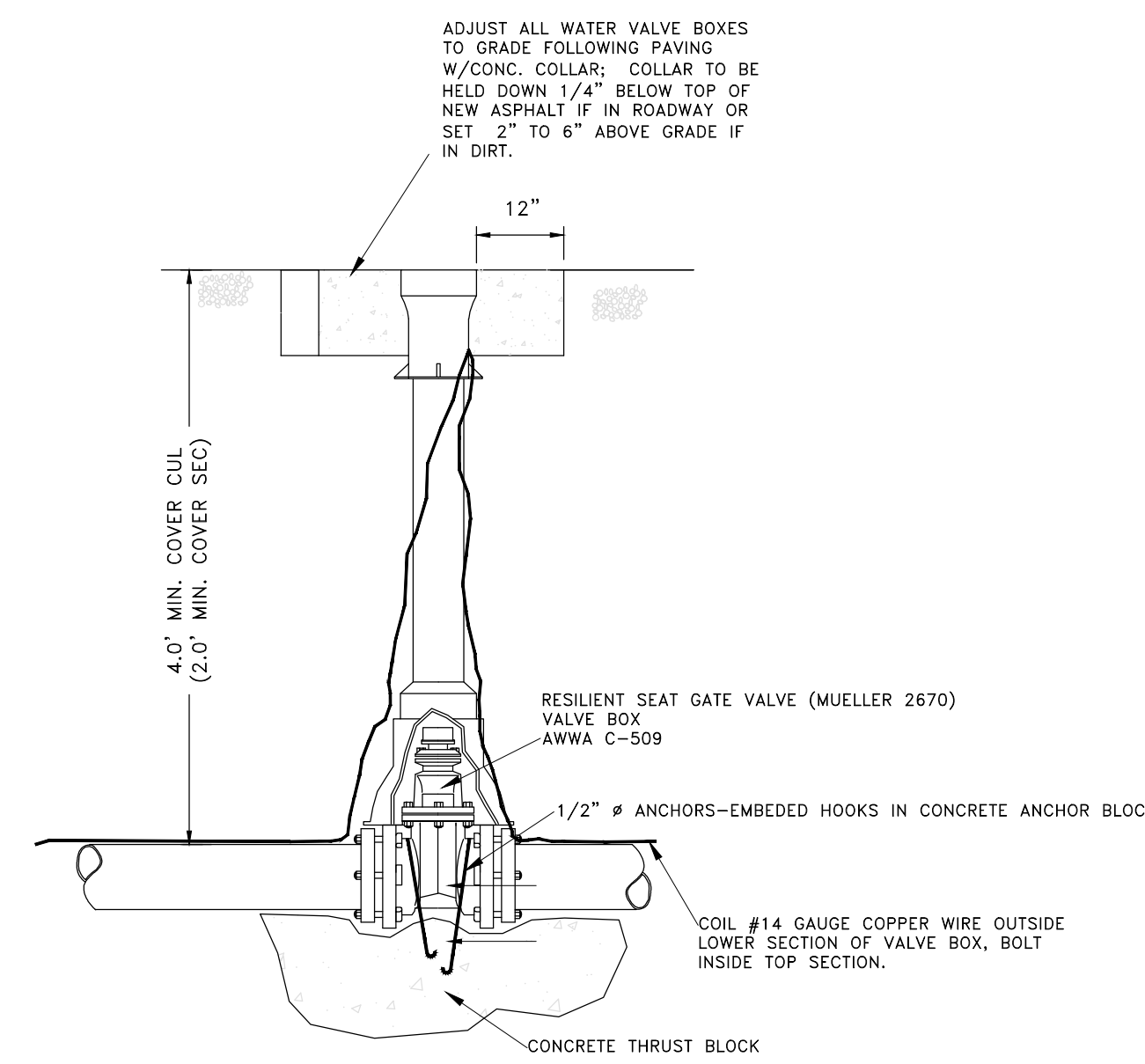

2 TYPICAL VALVE DETAIL
Scale: (NOT TO SCALE)
(CULINARY OR SECONDARY SEE INDIVIDUAL WATER COMPANY OR DISTRICT STANDARDS)

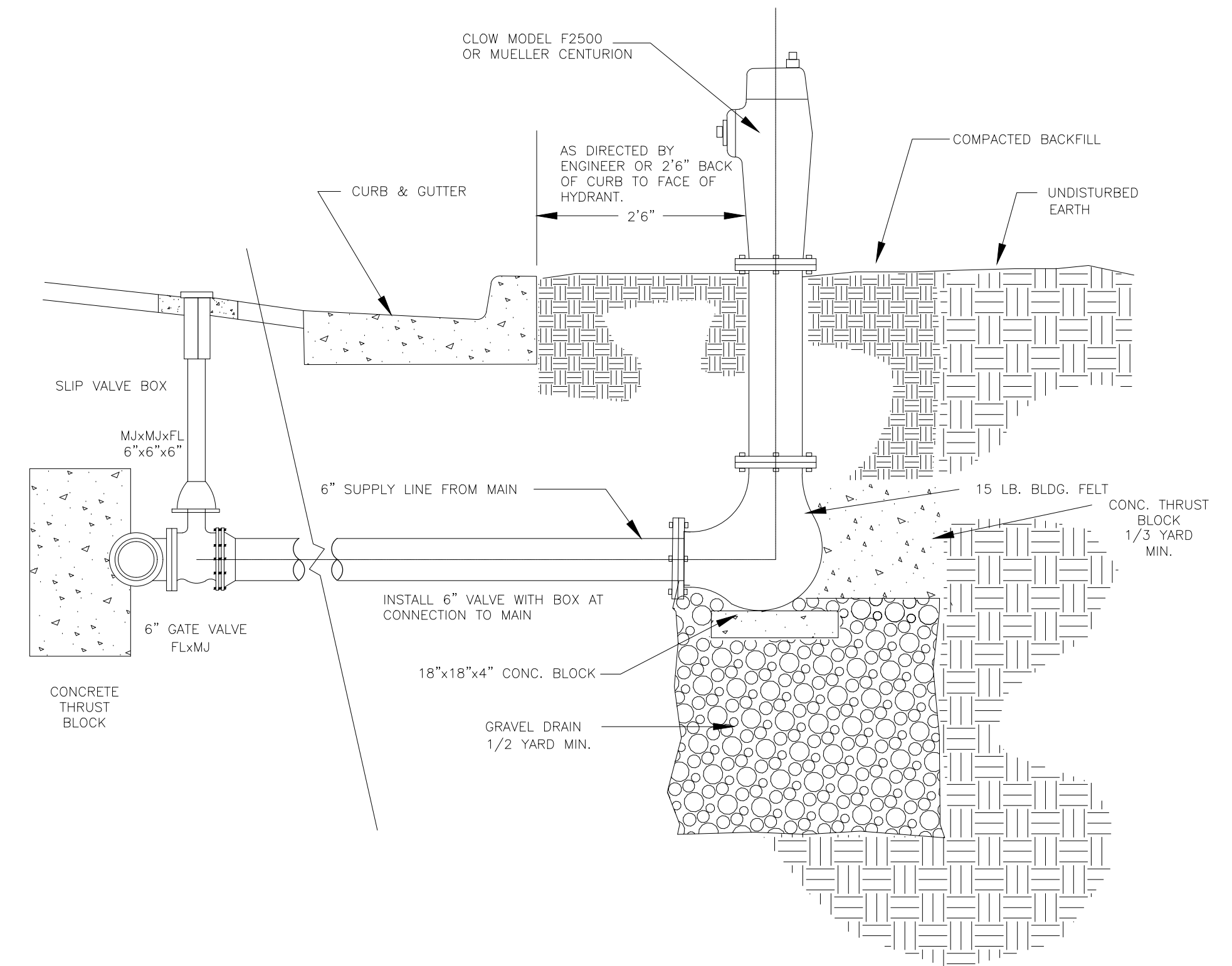

3 TYPICAL WATER HYDRANT DETAIL
Scale: (NOT TO SCALE)

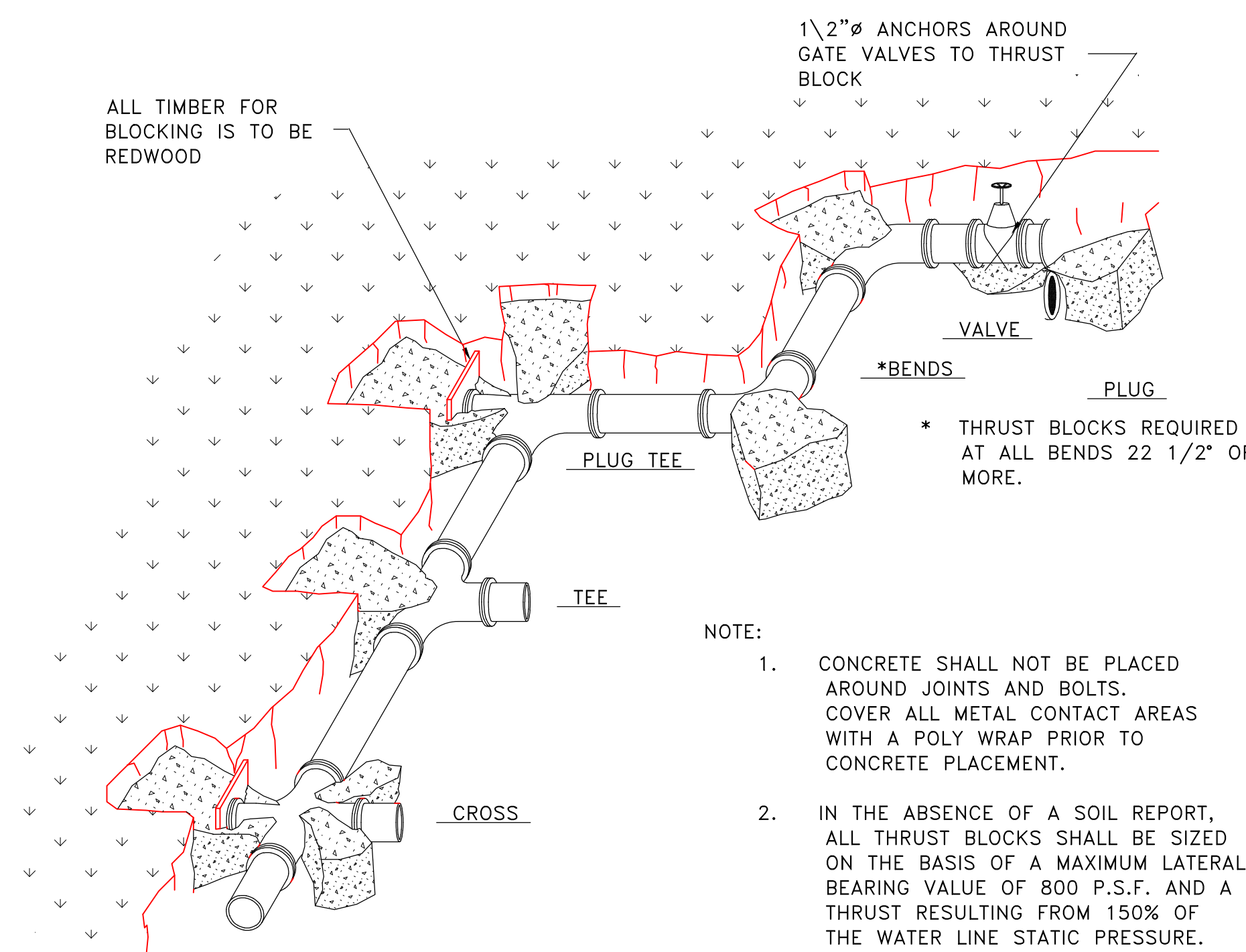

THRUST BLOCKING

- NOTE:
- CONCRETE SHALL NOT BE PLACED AROUND JOINTS AND BOLTS. COVER ALL METAL CONTACT AREAS WITH A POLY WRAP PRIOR TO CONCRETE PLACEMENT.
 - IN THE ABSENCE OF A SOIL REPORT, ALL THRUST BLOCKS SHALL BE SIZED ON THE BASIS OF A MAXIMUM LATERAL BEARING VALUE OF 800 P.S.F. AND A THRUST RESULTING FROM 150% OF THE WATER LINE STATIC PRESSURE.

IMPORTANT:
THIS DETAIL SHEET IS A MINIMUM REQUIREMENT STANDARD FOR CULINARY WATER SUPPLY UTILITIES AND IMPROVEMENTS. IN DEVELOPMENT AREAS WHERE NO STANDARDS EXIST, ALL CULINARY WATER FACILITIES AND IMPROVEMENTS SHALL BE CONSTRUCTED TO THE CITY STANDARD.

NOTE
TRENCH BACK FILL, INSTALLATION, TESTING AND DISINFECTING REQUIREMENTS:
ALL IMPORT MATERIAL AND BACKFILL TO BE COMPACTED TO 97% ASTM D-1557 IN ROADWAYS OR ANY LOAD BEARING SURFACE AND 90% IN LANDSCAPED AREAS OR NON LOAD BEARING SURFACES.
ALL BACKFILL AND COMPACTION SHALL TAKE PLACE IN 24" MAXIMUM DEPTH LIFTS WITH COMPACTION TESTING ON EACH LIFT. ALL COMPACTION TESTING SHALL BE PROVIDED AT THE EXPENSE OF THE CONTRACTOR PERFORMING THE WORK. THE CITY SHALL REVIEW AND INSPECT COMPACTION PROCEDURES AND TEST RESULTS FOR COMPLIANCE WITH CITY REQUIREMENTS.
ALL PRESSURE PIPE SYSTEMS TO BE FLUSHED AND PRESSURE TESTED AT A MINIMUM OF 1.5 TIMES THE MAXIMUM STATIC PRESSURE FOR 2 HOURS OR AS REQUIRED BY THE CONTROLLING WATER COMPANY OR DISTRICT.
CULINARY PIPE SYSTEMS TO BE DISINFECTED AND TESTED TO THE CONTROLLING COMPANY OR DISTRICT STANDARDS. IF THE SYSTEM IS TO BE OWNED OR OPERATED BY WEST HAVEN CITY THEN THE SYSTEM SHALL BE TESTED USING CURRENT STATE STANDARDS

TABLE OF BEARING AREAS IN SQ. FT FOR CONCRETE THRUST BLOCKING

SIZE	BENDS			TEES*	GATE VALVES	DEAD ENDS	CROSSW/ BRANCH PLUGGED	CROSSW/ 2 BRAN. PLUGGED
	45°	22 1/2°	11 1/2°					
3	1.0	0.0	0.3	0	0.7	0.5	0.7	0.7
4	1.8	1.0	0.5	0	1.3	0.5	1.3	1.3
6	4.0	2.2	1.1	0	2.8	0.7	2.8	2.8
8	7.1	3.8	2.0	1.0	5.0	2.4	5.0	5.0
10	11.1	6.0	3.0	1.5	7.8	4.5	7.8	7.8
12	16.0	8.6	4.4	2.2	11.3	7.3	11.3	11.3
14	21.7	11.8	6.0	3.0	15.4	11.0	15.4	15.4
15	25.0	13.5	7.0	3.5	17.6	12.6	17.6	17.6
16	28.4	15.3	8.0	4.0	20.0	14.3	20.0	20.0
18	36.0	19.4	10.0	5.0	25.4	18.0	25.4	25.4
20	44.2	24.0	12.2	6.1	31.4	22.0	31.4	31.4
21	49.0	26.5	13.5	6.8	34.6	24.0	34.6	34.6
22	54.0	29.0	14.8	7.4	38.0	26.0	38.0	38.0
24	64.0	34.5	17.7	8.8	45.0	31.0	45.0	45.0
30	100.0	54.0	27.6	13.8	71.0	51.0	71.0	71.0
36	144.0	78.0	40.0	20.0	102.0	71.0	102.0	102.0

*SIZE IS BRANCH SIZE.
FOR 100 P.S.I. INTERNAL STATIC PRESSURE AND 1000 LBS.PER SQ. FT. SOIL BEARING CAPACITY.

THRUST BLOCKING DETAIL
APPLIES TO ALL PRESSURE PIPE

ALL VALVES, TEES, CROSSES AND BENDS GREATER THAN 22.5" SHALL ALSO BE FITTED WITH MECHANICAL RESTRAINTS, SUCH AS MEGA LUGS OR APPROVED EQUAL.

AREAS GIVEN IN TABLE ARE BASED UPON AN INTERNAL STATIC PRESSURE OF 100 P.S.I AND A SOIL BEARING CAPACITY OF 1000 LBS PER SQ. FT. BEARING AREAS FOR ANY PRESSURE AND SOIL BEARING CAPACITY MAY BE OBTAINED BY MULTIPLYING THE TABULATED VALUES BY A CORRECTION FACTOR "F".

F = ACTUAL SPECIFIED TEST PRESSURE IN HUNDREDS OF LBS/SQ. IN.
ACTUAL SOIL BEARING CAPACITY IN THOUSANDS OF LBS.

EXAMPLE: TO FIND BEARING AREA FOR 8"-90° BEND WITH A STATIC INTERNAL PRESSURE OF 1500 P.S.I AND WITH A SOIL BEARING CAPACITY OF 3000 LBS. PER SQ. FT.
F = 1.5 / 3 = 0.5 TABULATED VALUE = 7.1 SQ. FT.
0.5 X 7.1 = 3.56 ~ 4 SQ. FT. (~OR 2FT. LONG BY 2FT. HIGH.)

SCALE	1"=50'
DATE	1/4/2023
DESIGN	WJS
DRAWN	WJS
CHECKED	TJM

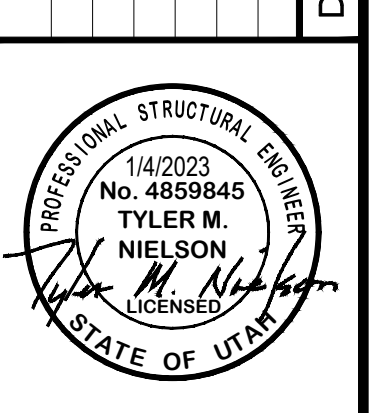

CIVIL UTILITY DETAILS
RY GENERAL
546 EAST OLD FORT ROAD
SOUTH WEBER CITY, DAVIS COUNTY, UTAH

GARDNER ENGINEERING
CIVIL-LAND PLANNING
MUNICIPAL-LAND SURVEYING
5150 SOUTH 375 EAST OGDEN, UT
OFFICE: 801-476-0202 FAX: 801-476-0066

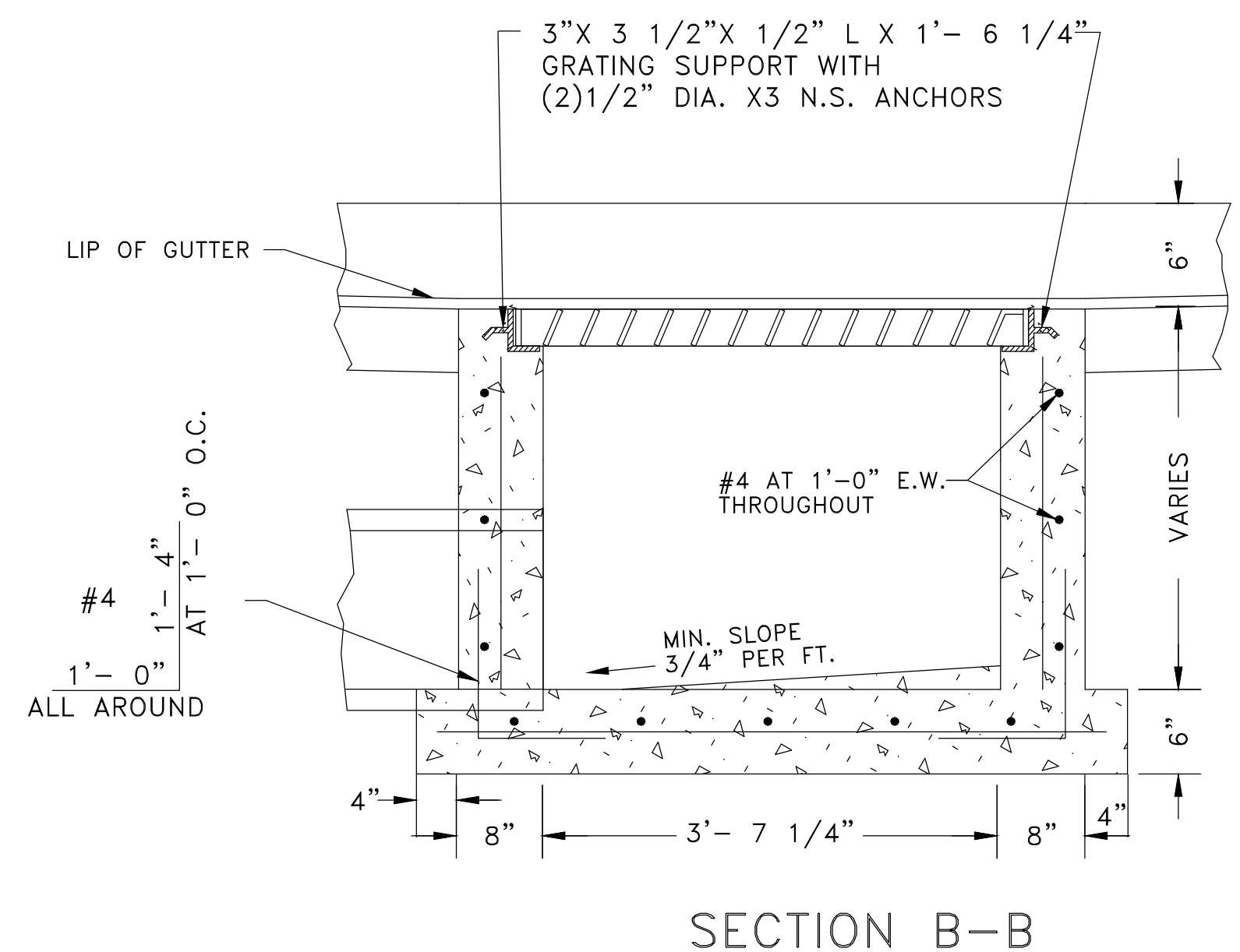
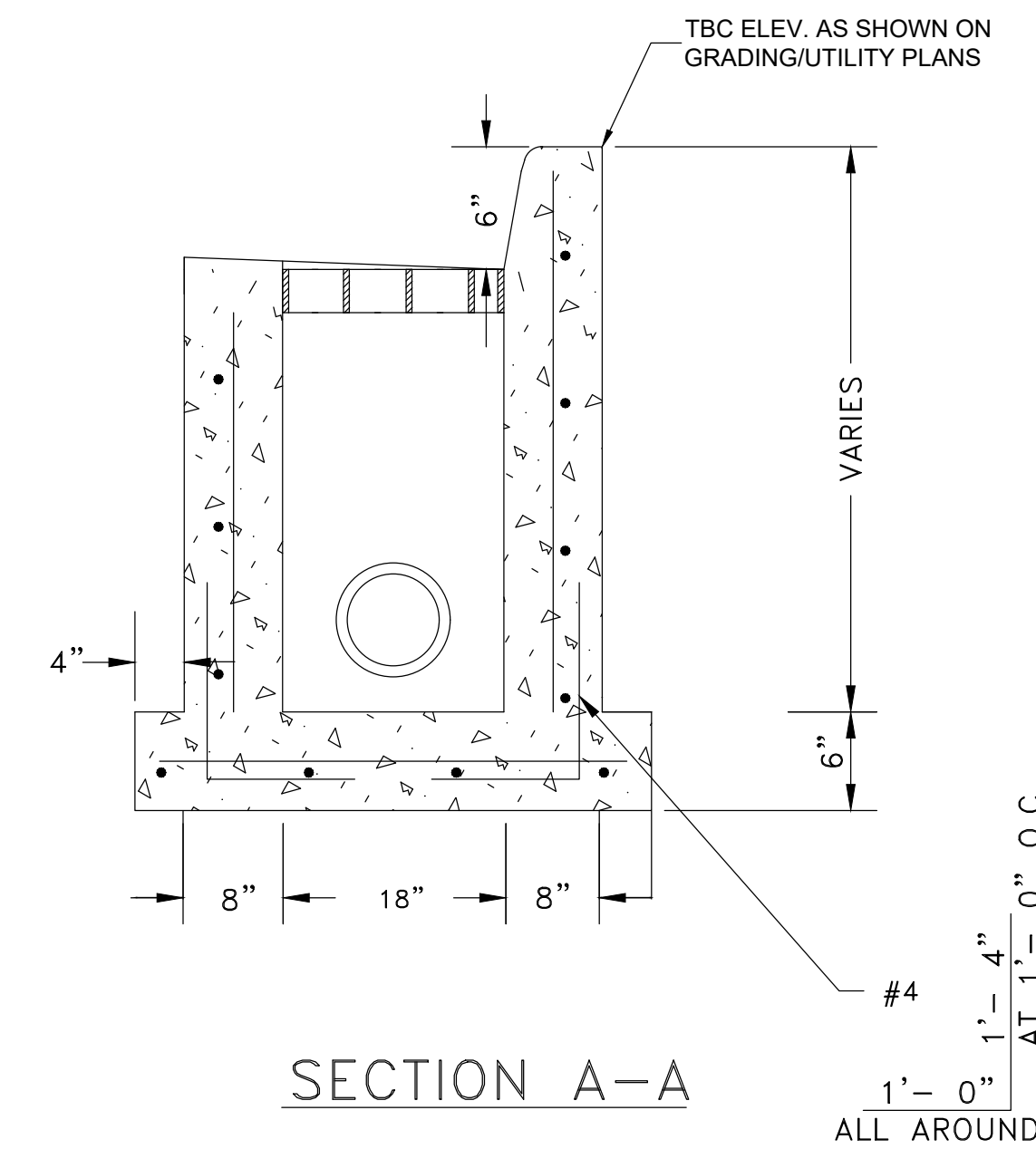
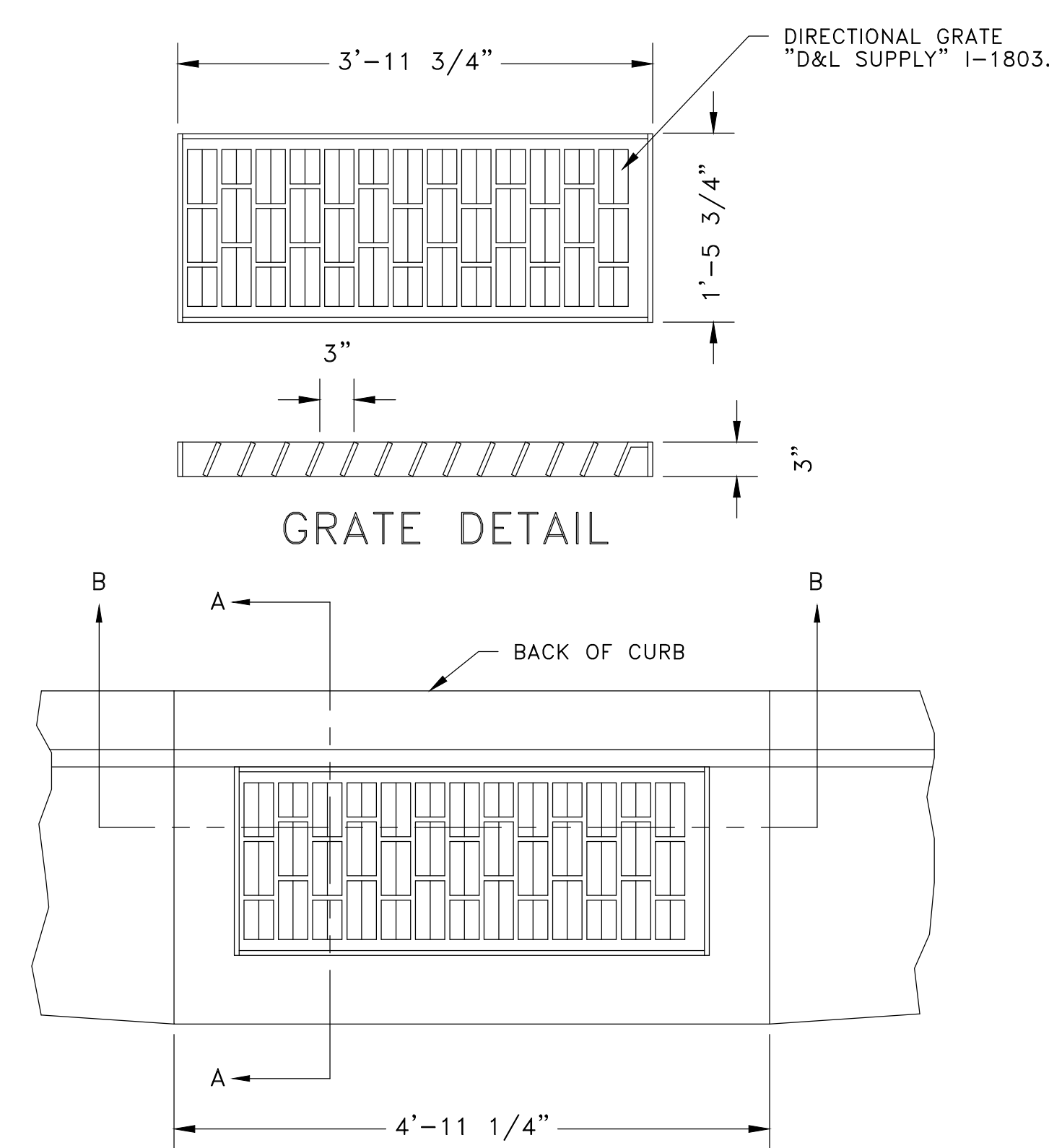

4 18-INCH CURB INLET BOX
Scale: (NOT TO SCALE)

PLAN

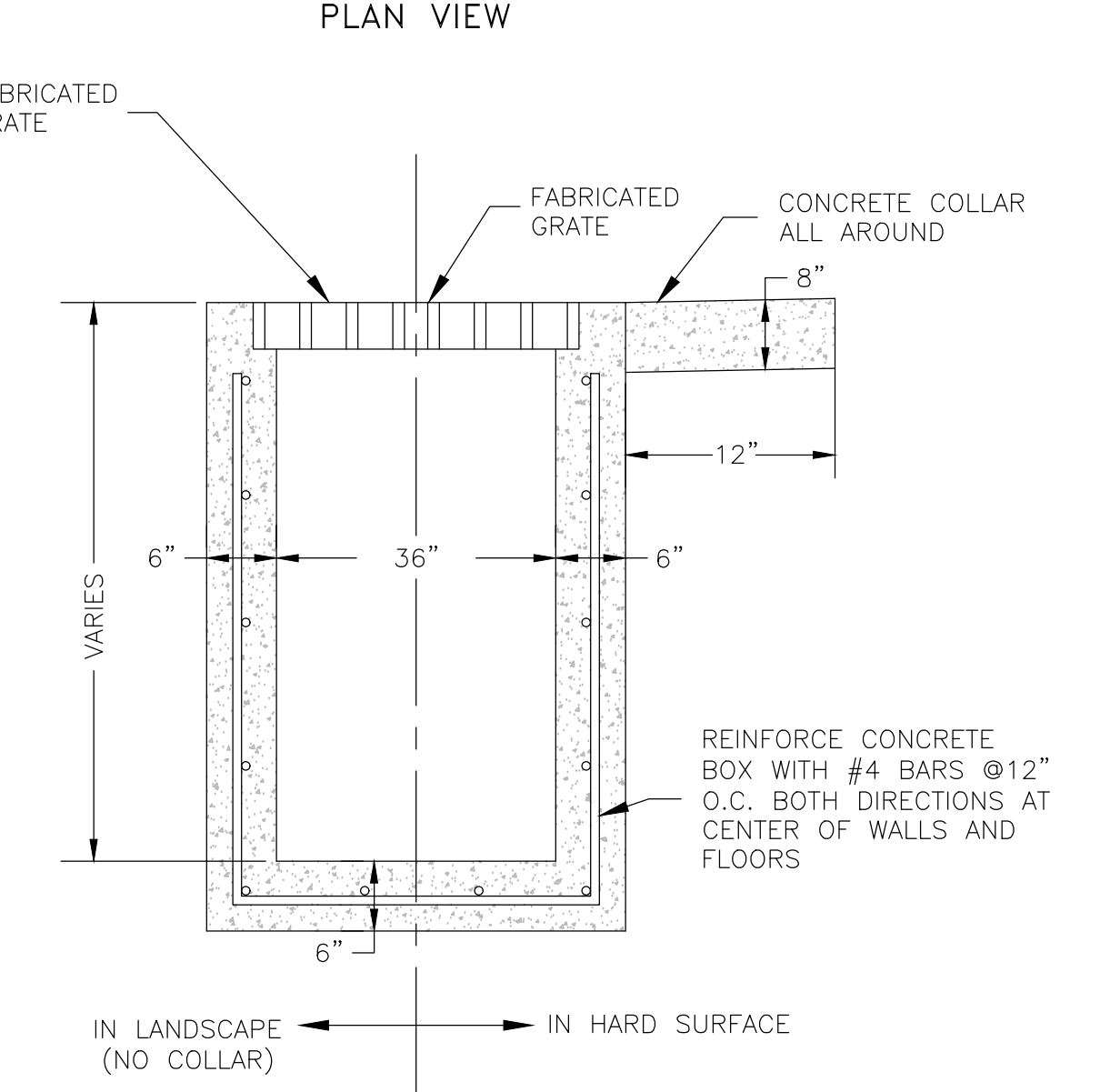
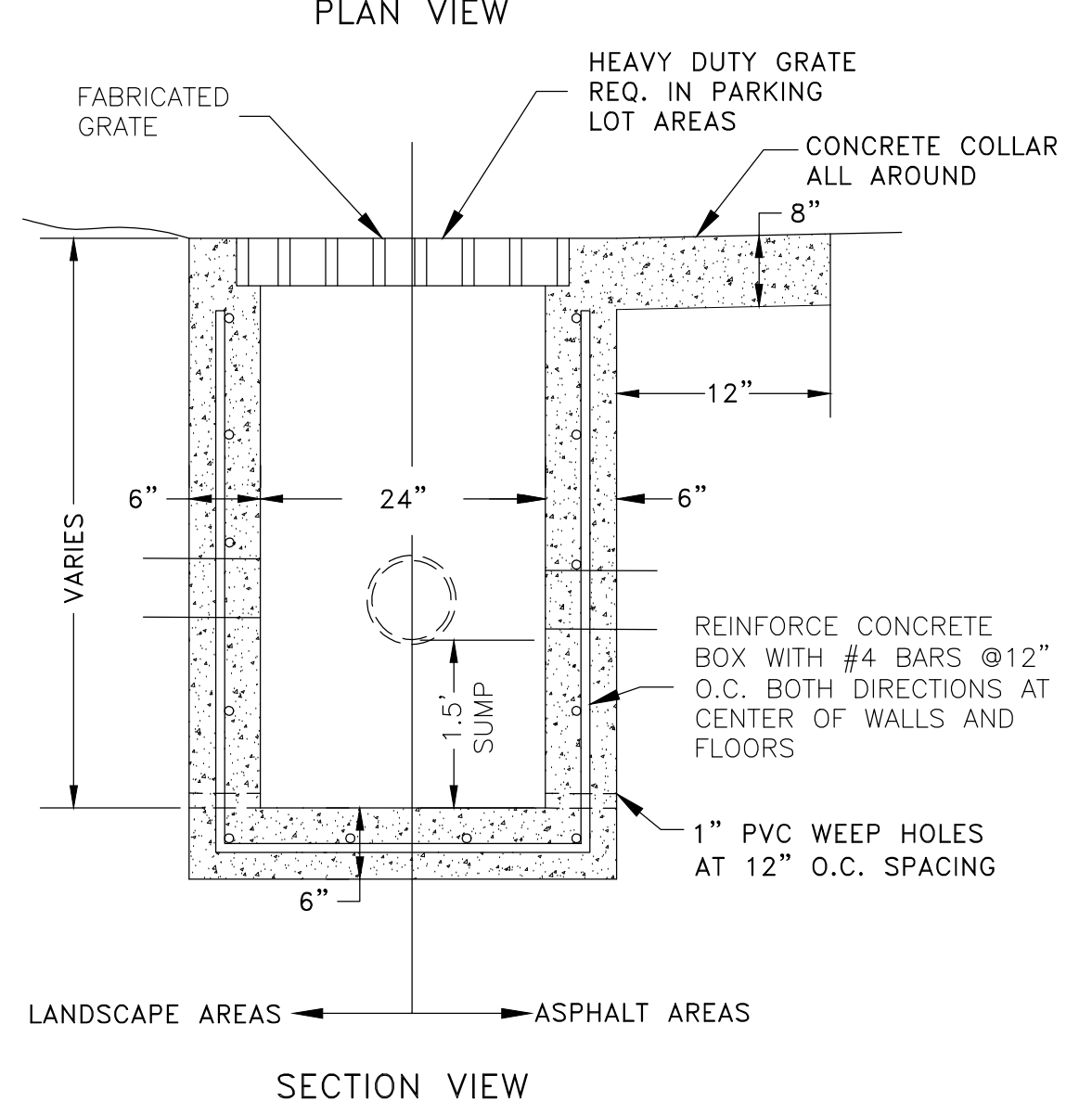
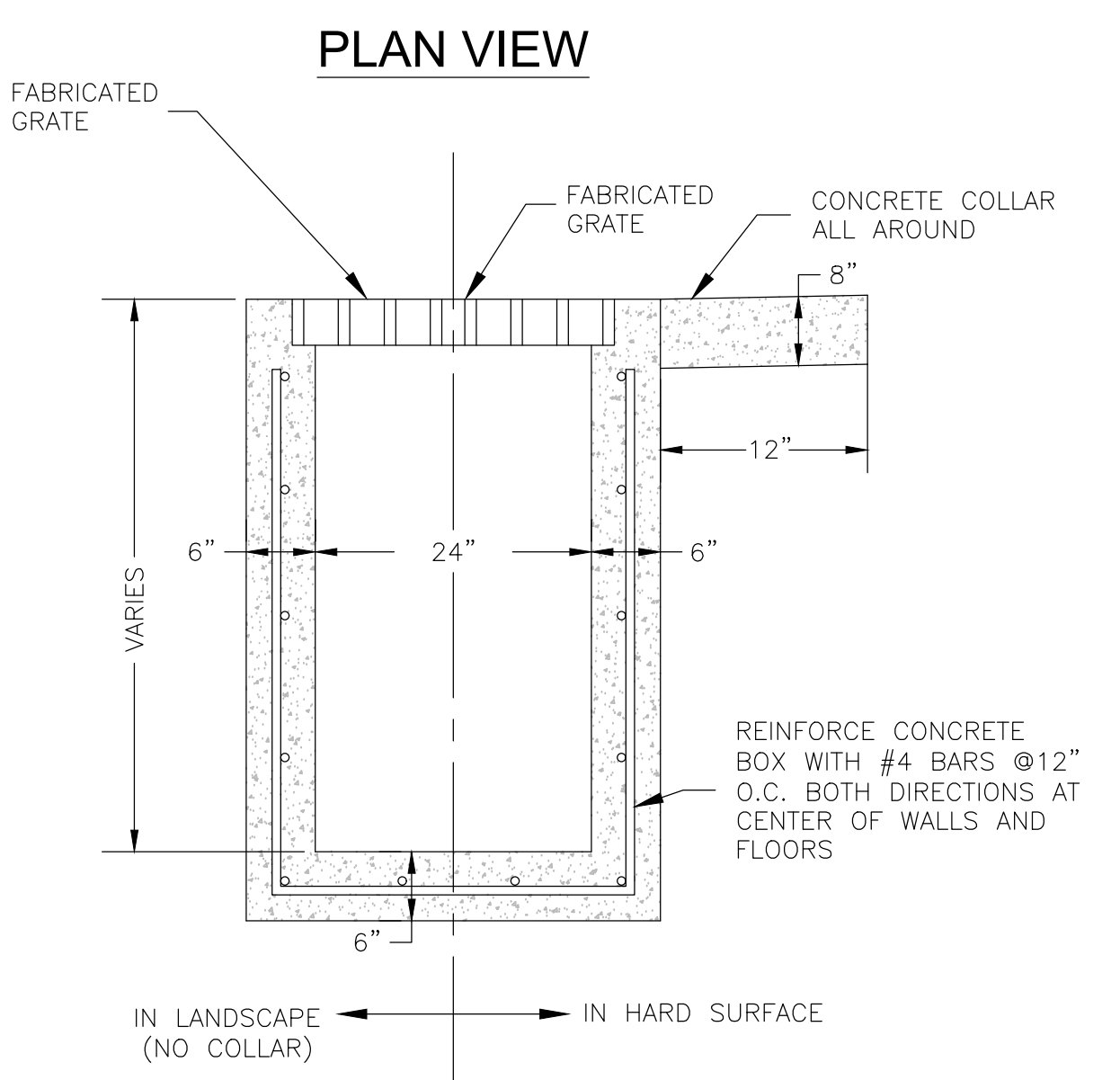
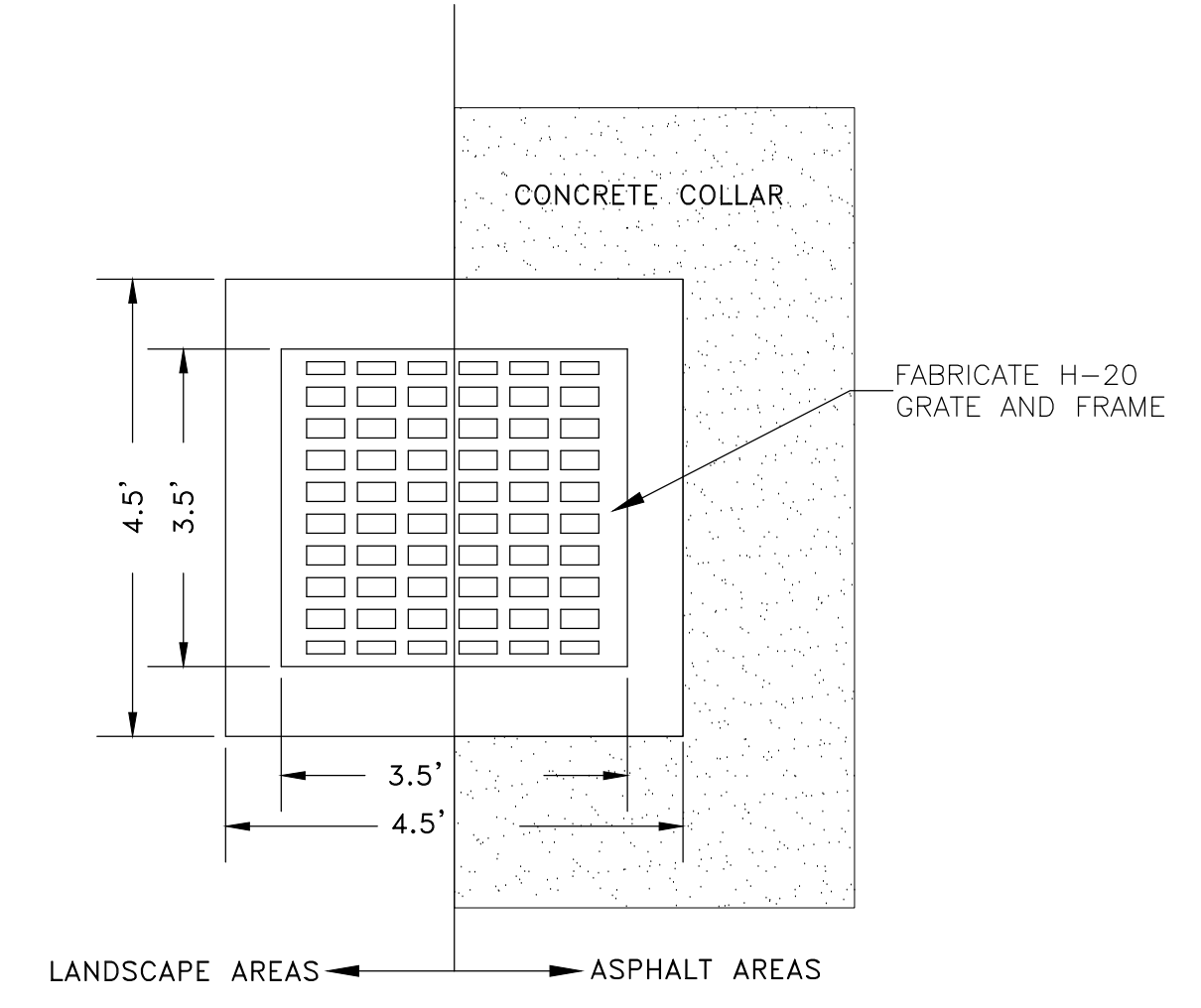
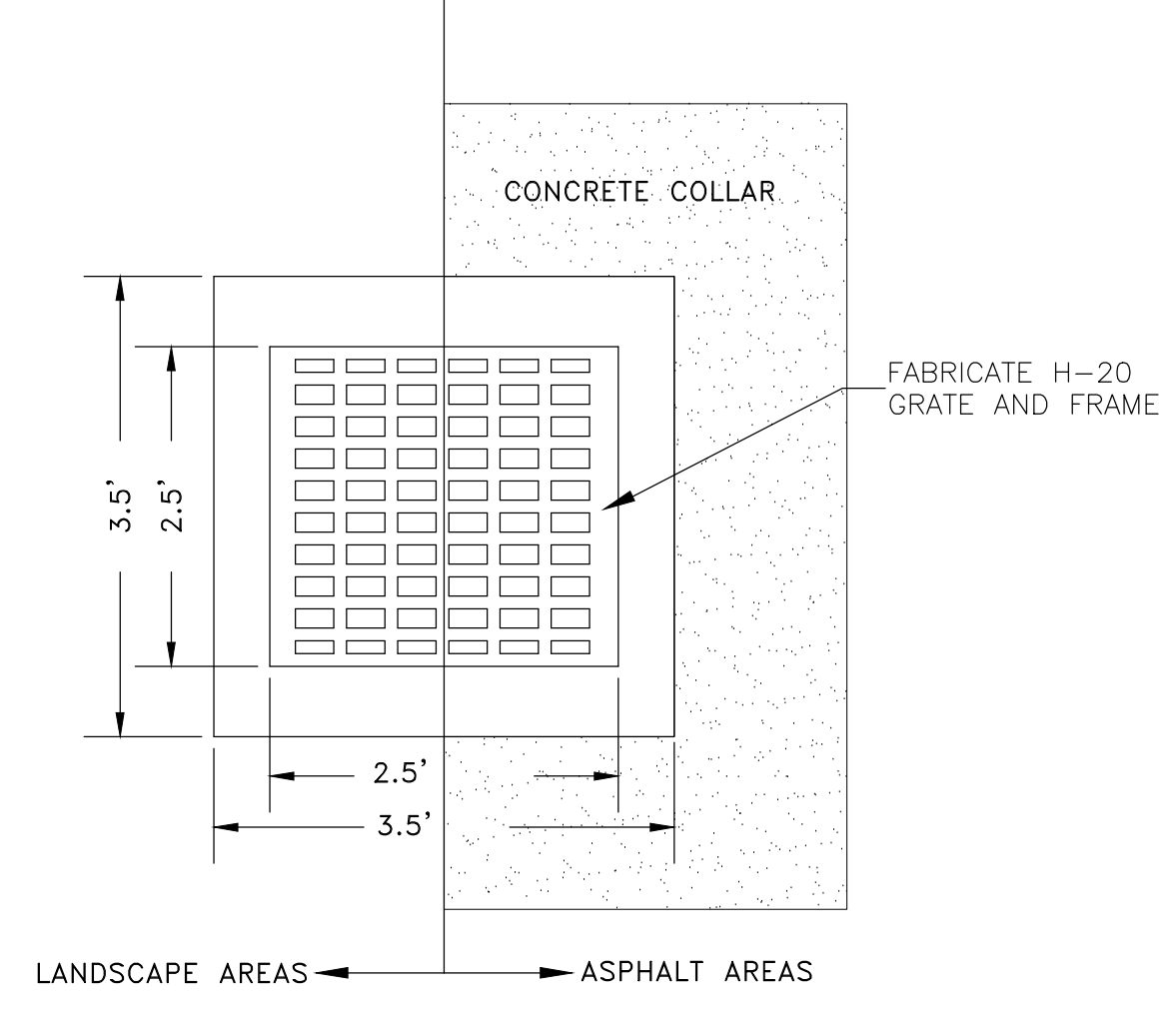
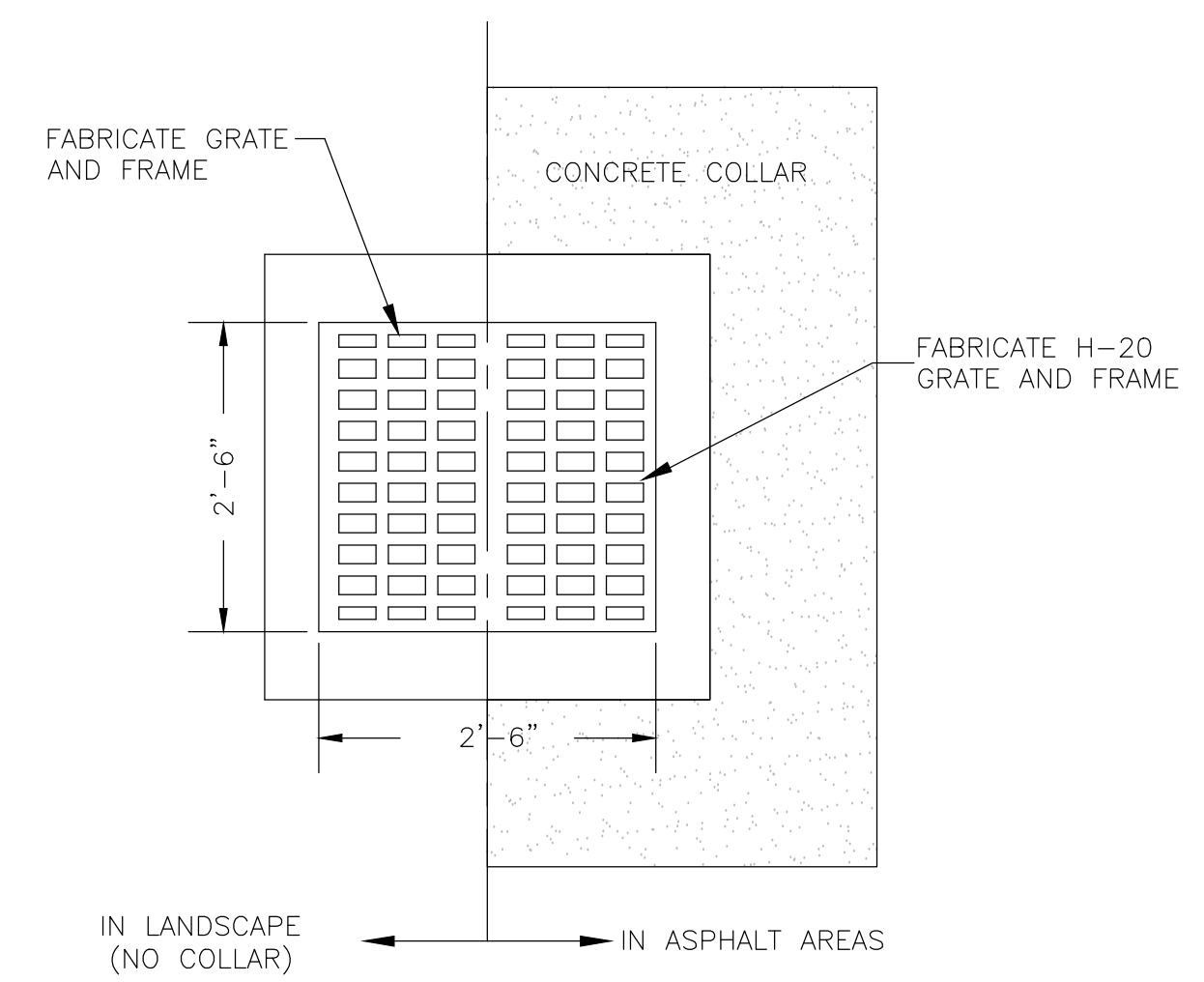

5 24-INCH CATCH BASIN BOX (NO SUMP)
Scale: (NOT TO SCALE)

6 24-INCH CATCH BASIN W/ SUMP
Scale: (NOT TO SCALE)

7 36-INCH CATCH BASIN BOX (NO SUMP)
Scale: (NOT TO SCALE)

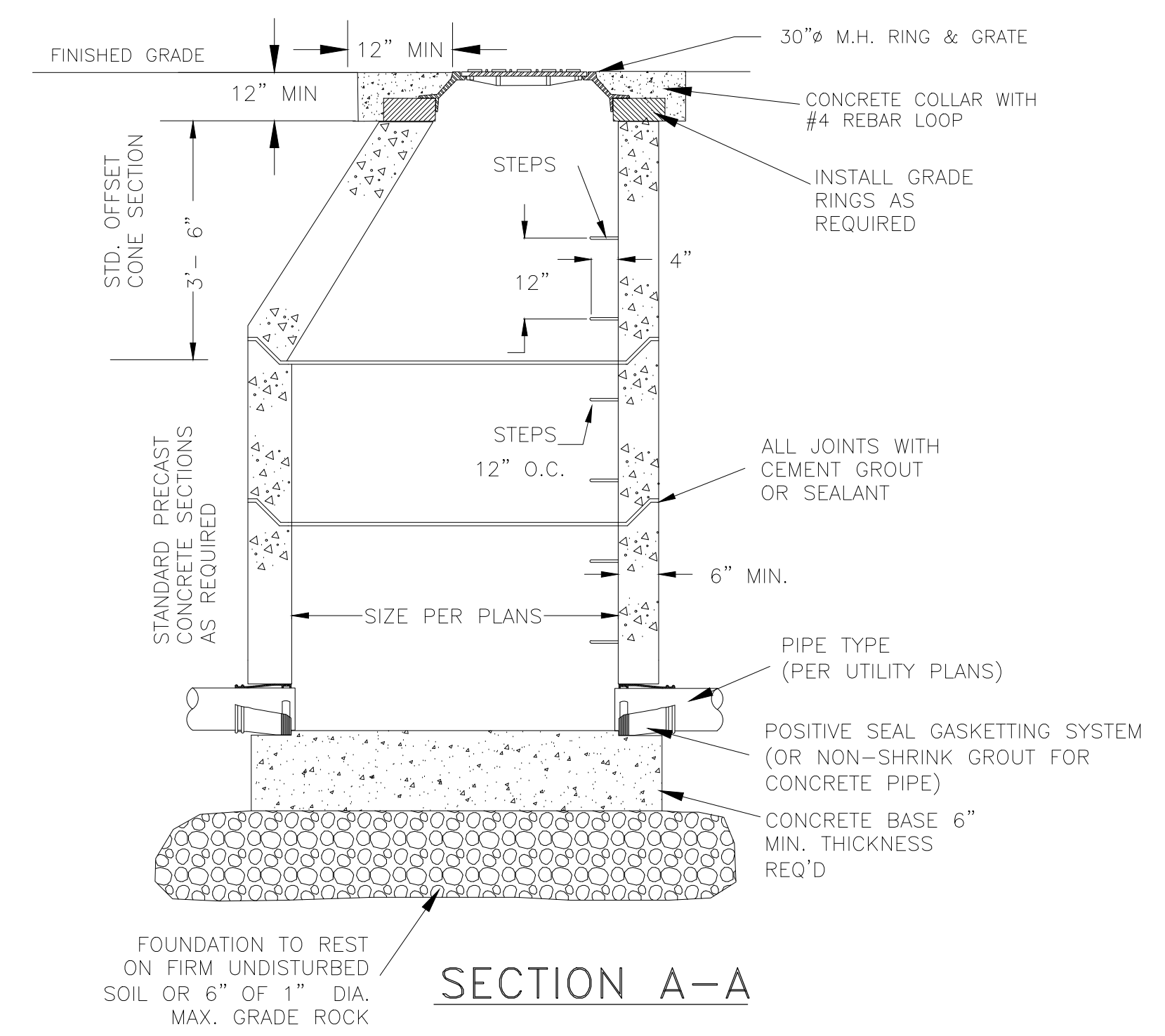
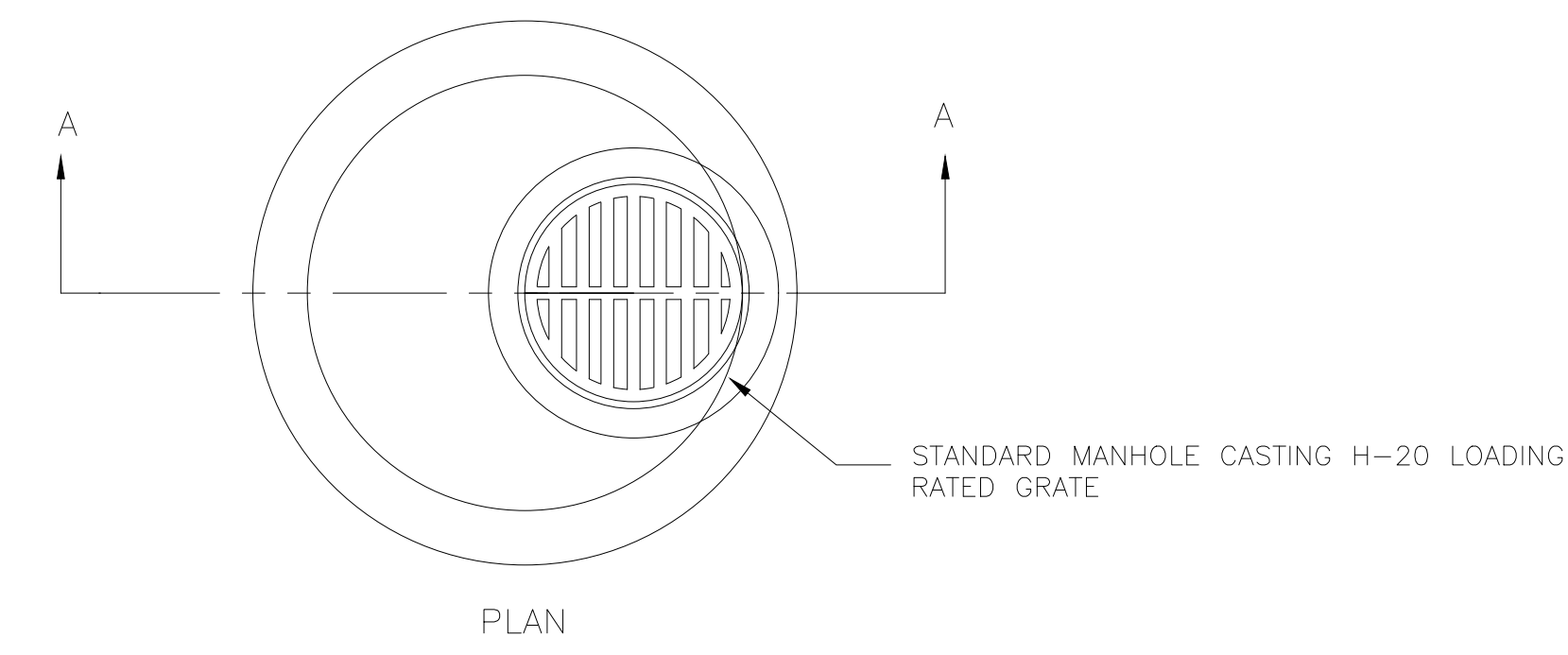

8 STORM DRAIN / CANAL IRRIGATION MANHOLE
Scale: (NOT TO SCALE)

SCALE	1"=5'
DATE	1/4/2023
DESIGN	WJS
DRAWN	WJS
CHECKED	TJM

REVISIONS	DESCRIPTION
DATE	

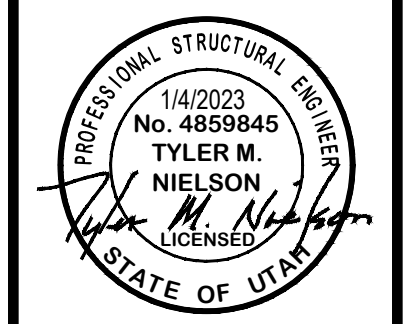

CIVIL UTILITY DETAILS
 RV GENERAL
 546 EAST OLD FORT ROAD
 SOUTH WEBER CITY, DAVIS COUNTY, UTAH



5150 SOUTH 375 EAST OGDEN, UT
 OFFICE: 801-476-0202 FAX: 801-476-0066

CE5-04

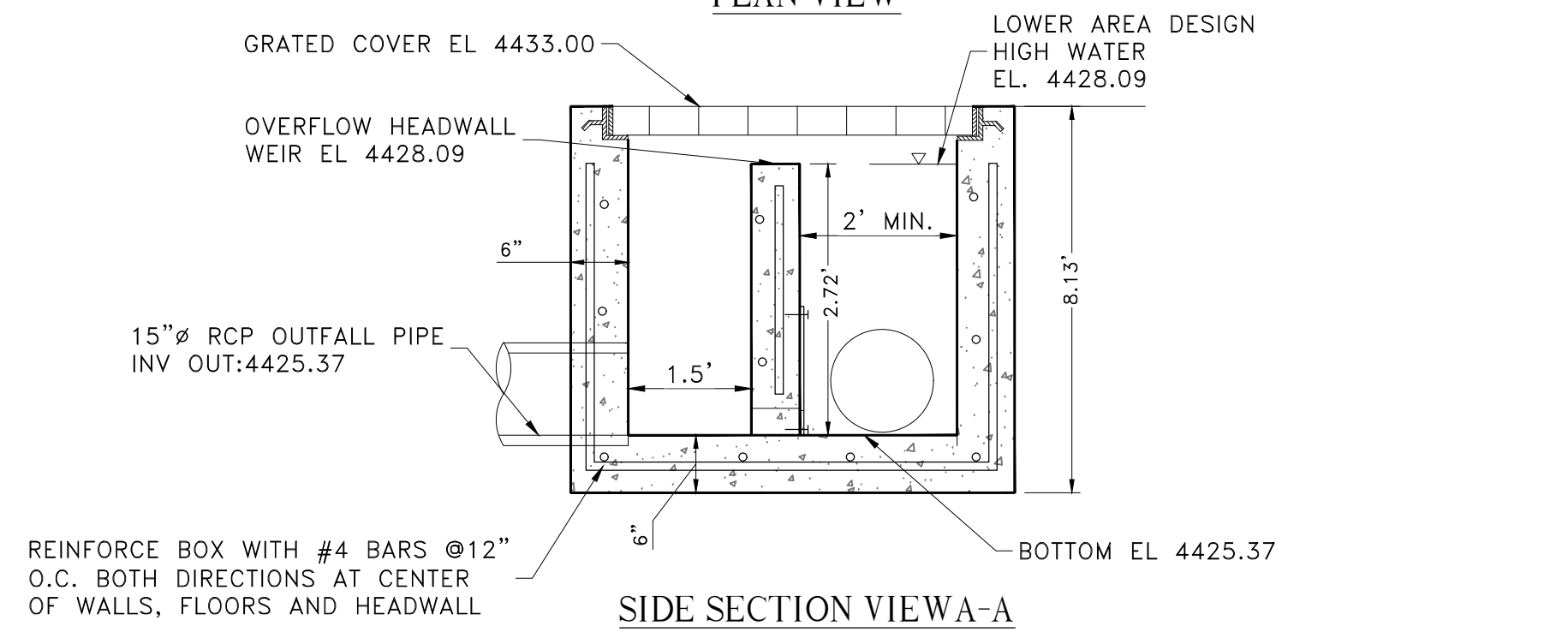
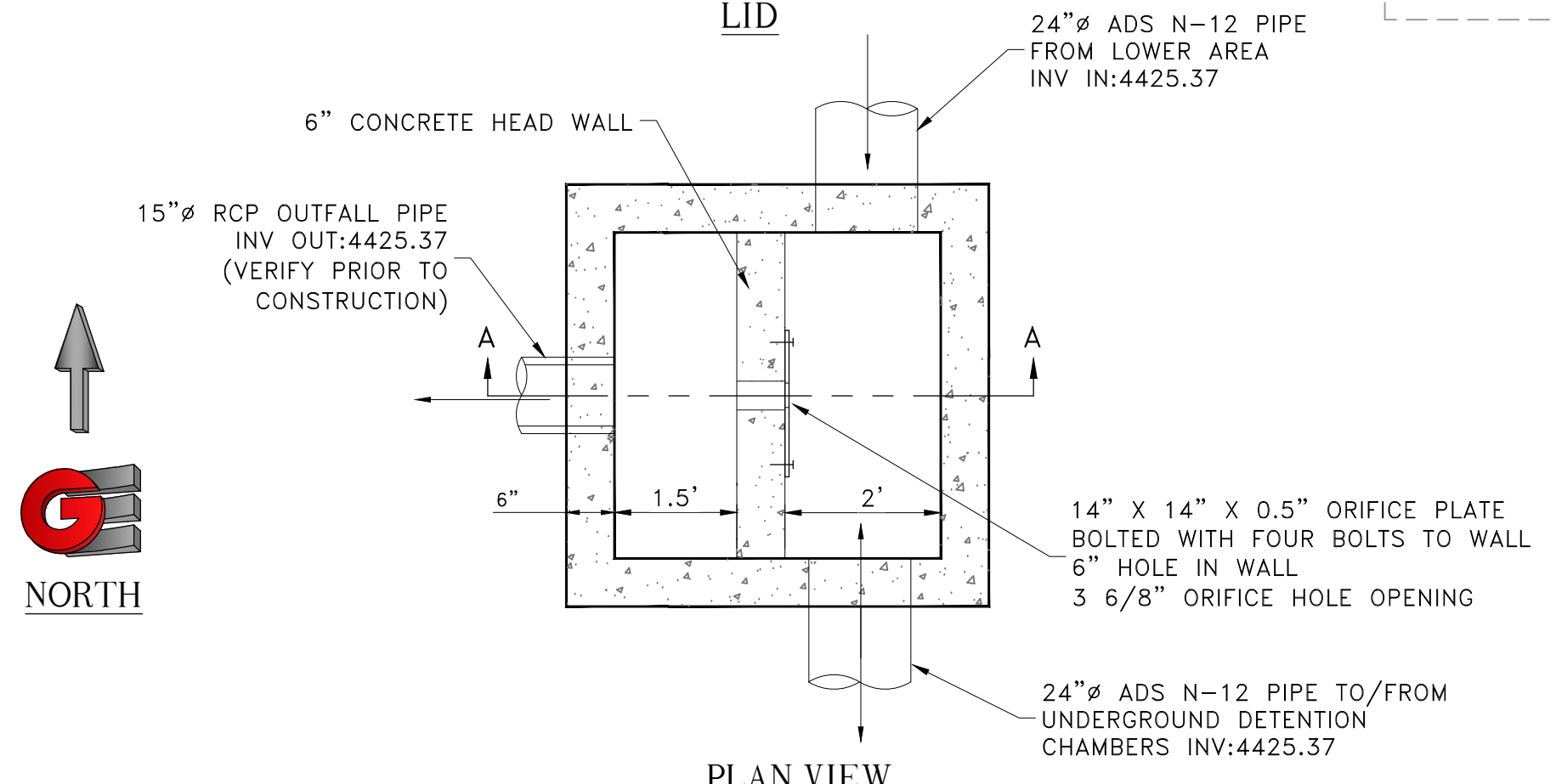
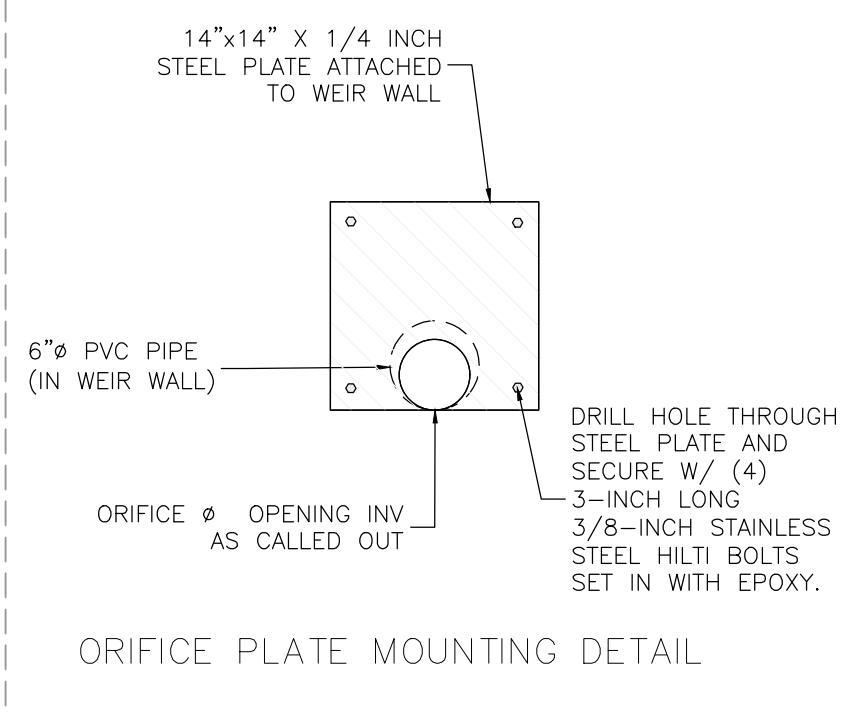
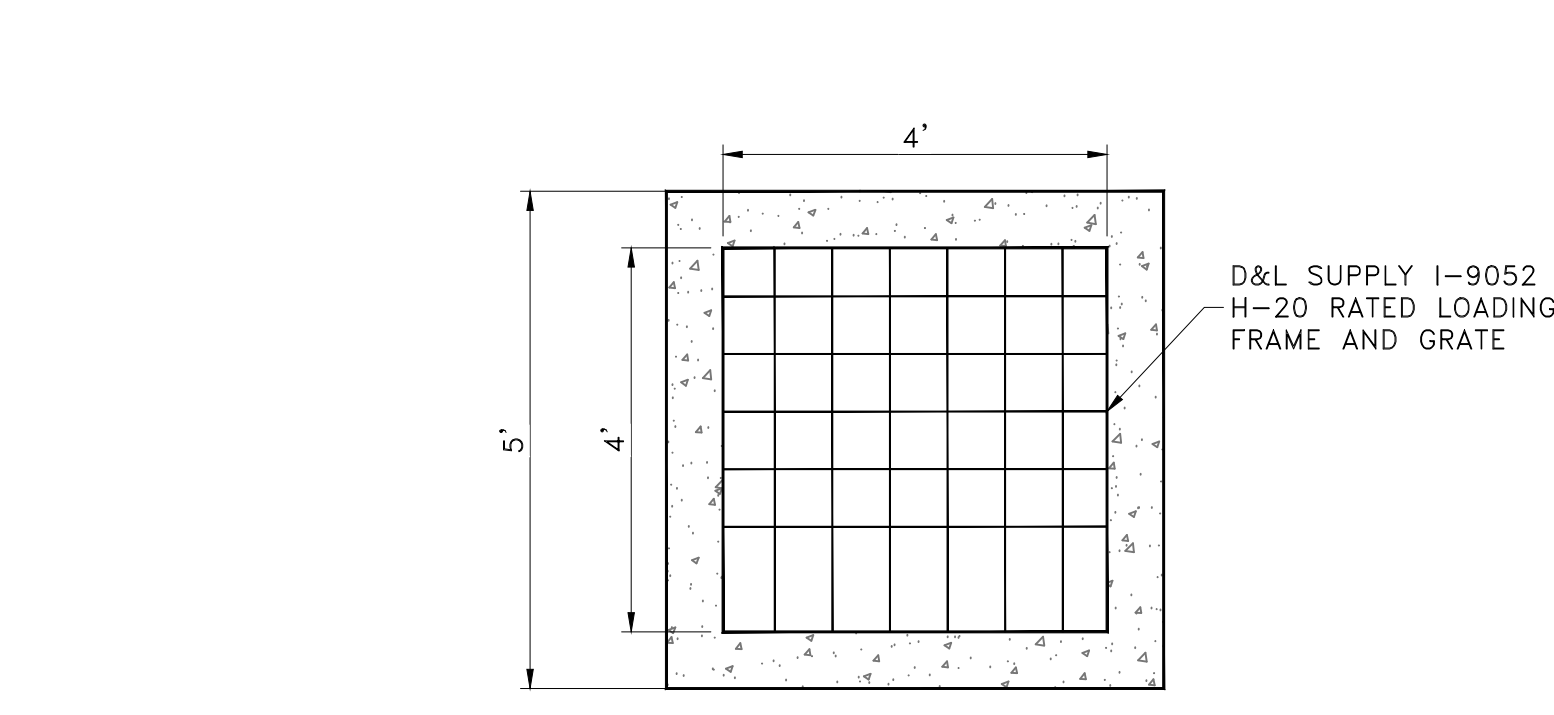

9 4' x 4' STORM DRAIN OUTLET CONTROL BOX-1
Scale: NTS

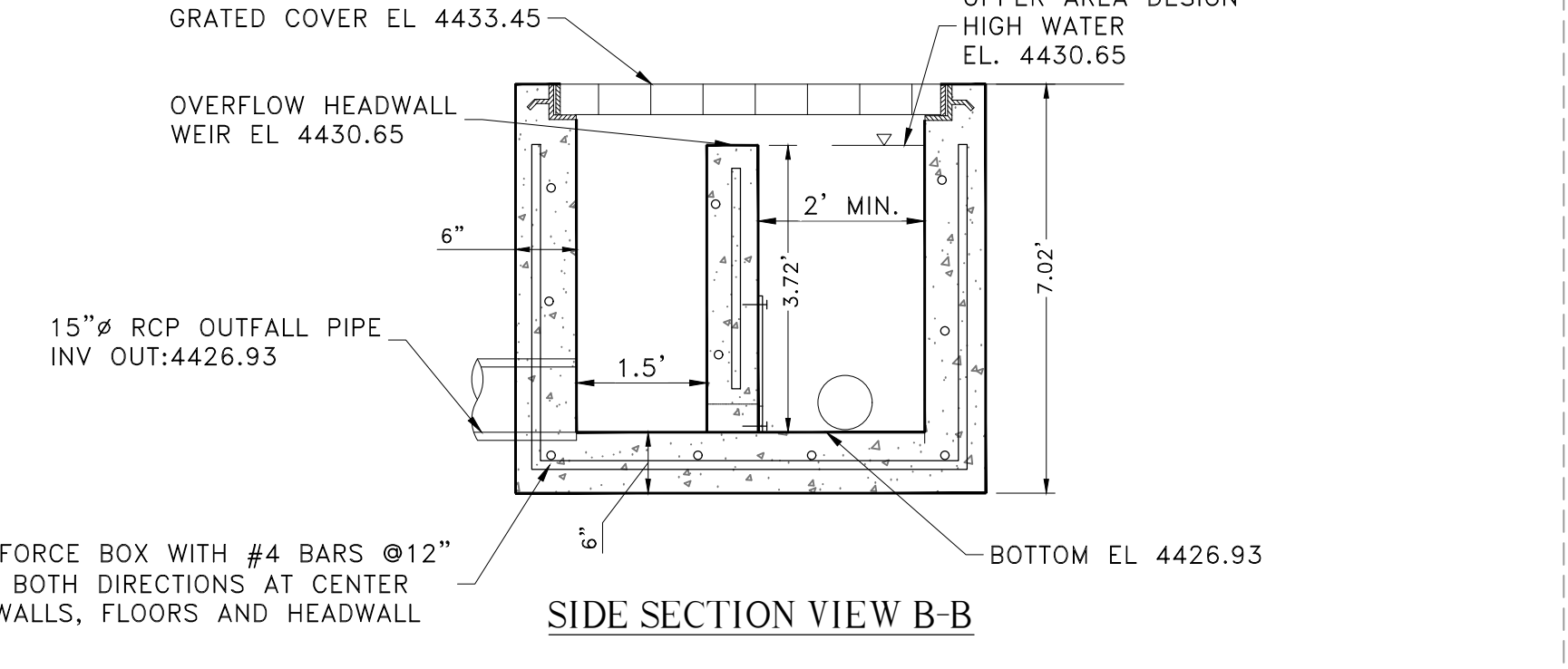
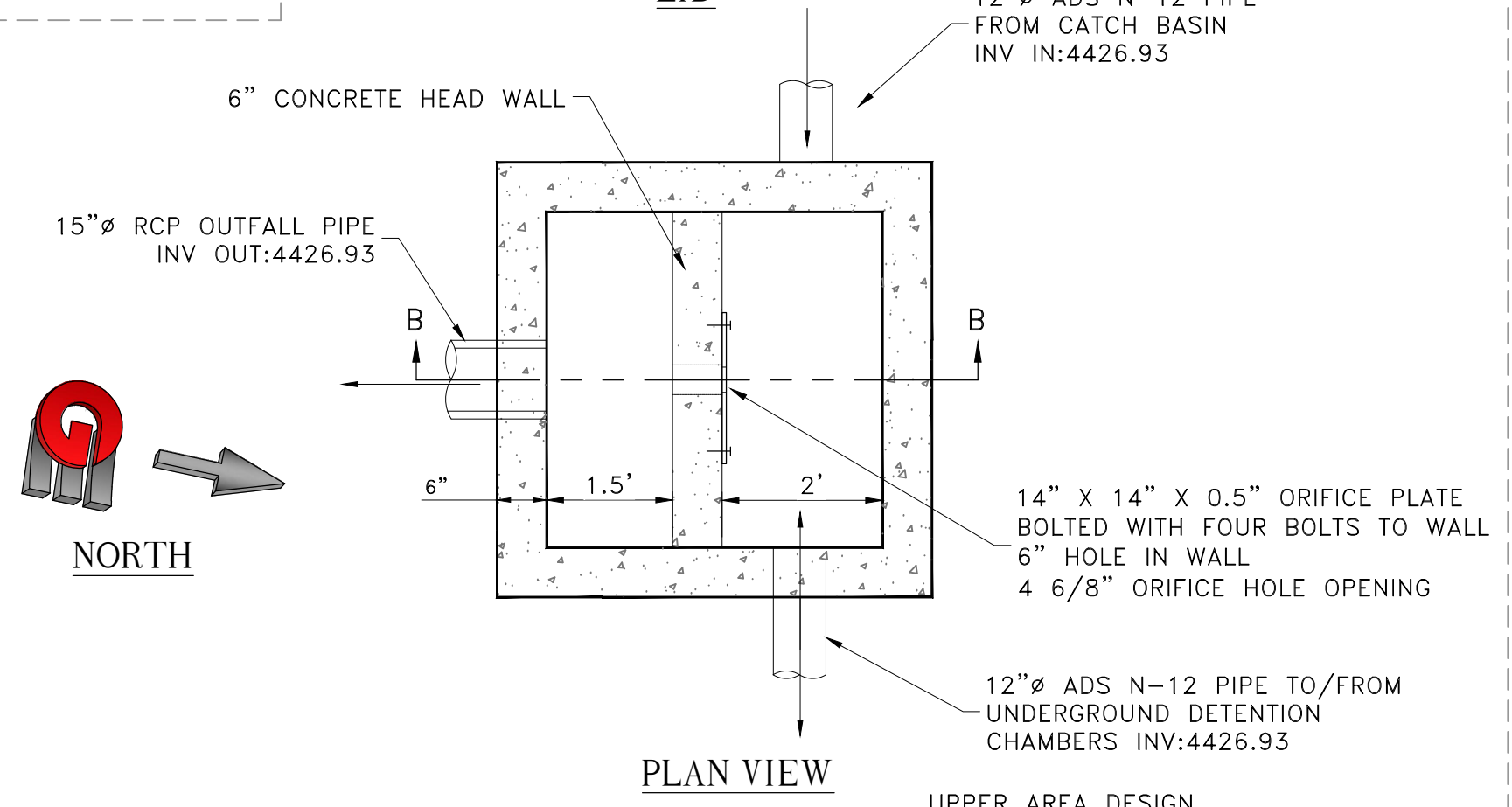
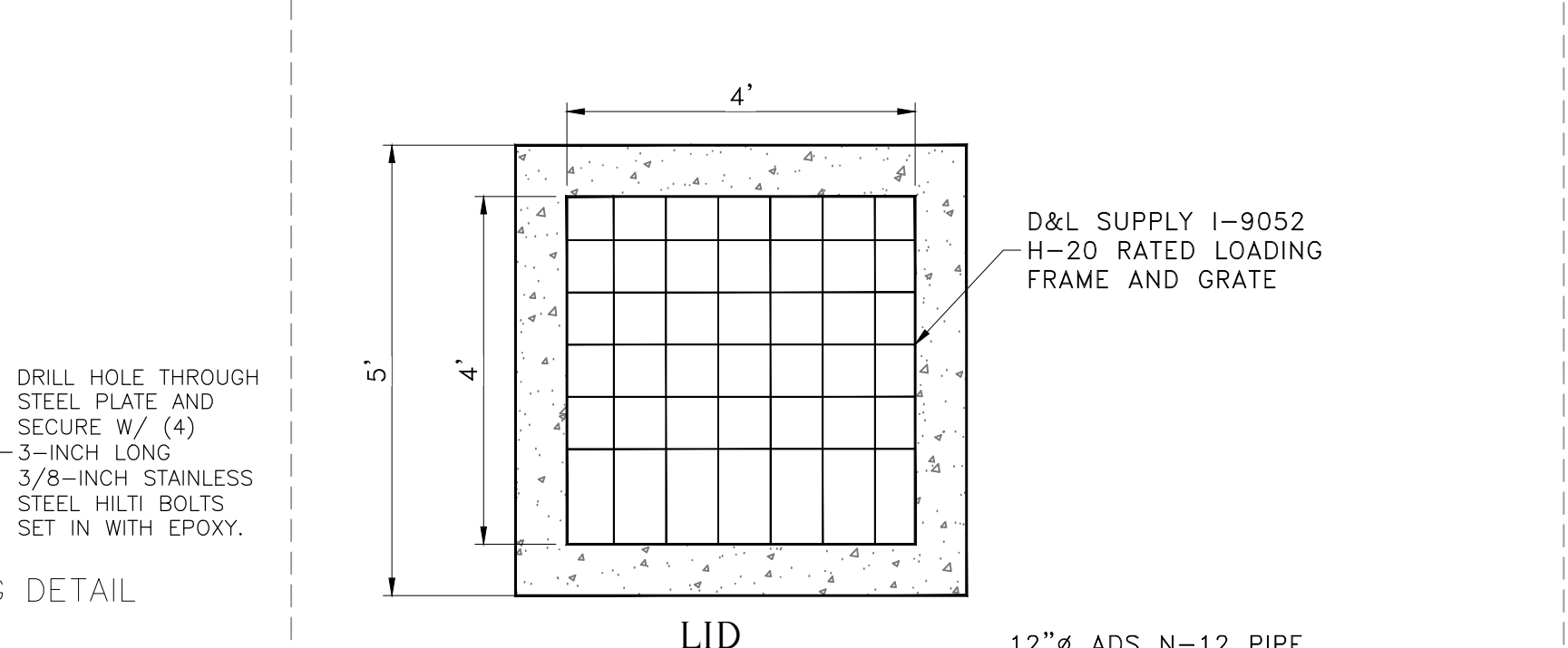

10 4' x 4' STORM DRAIN OUTLET CONTROL BOX-2
Scale: NTS

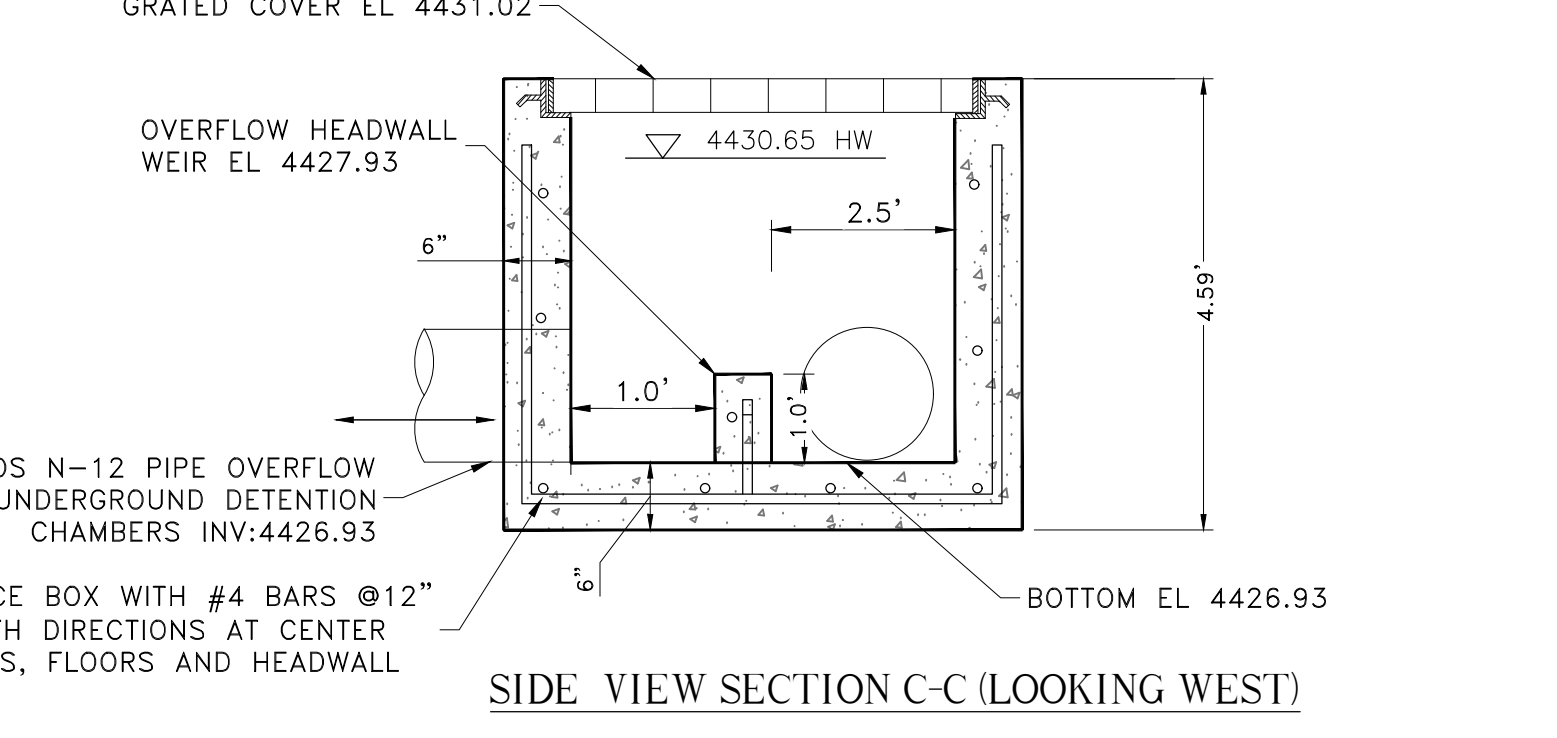
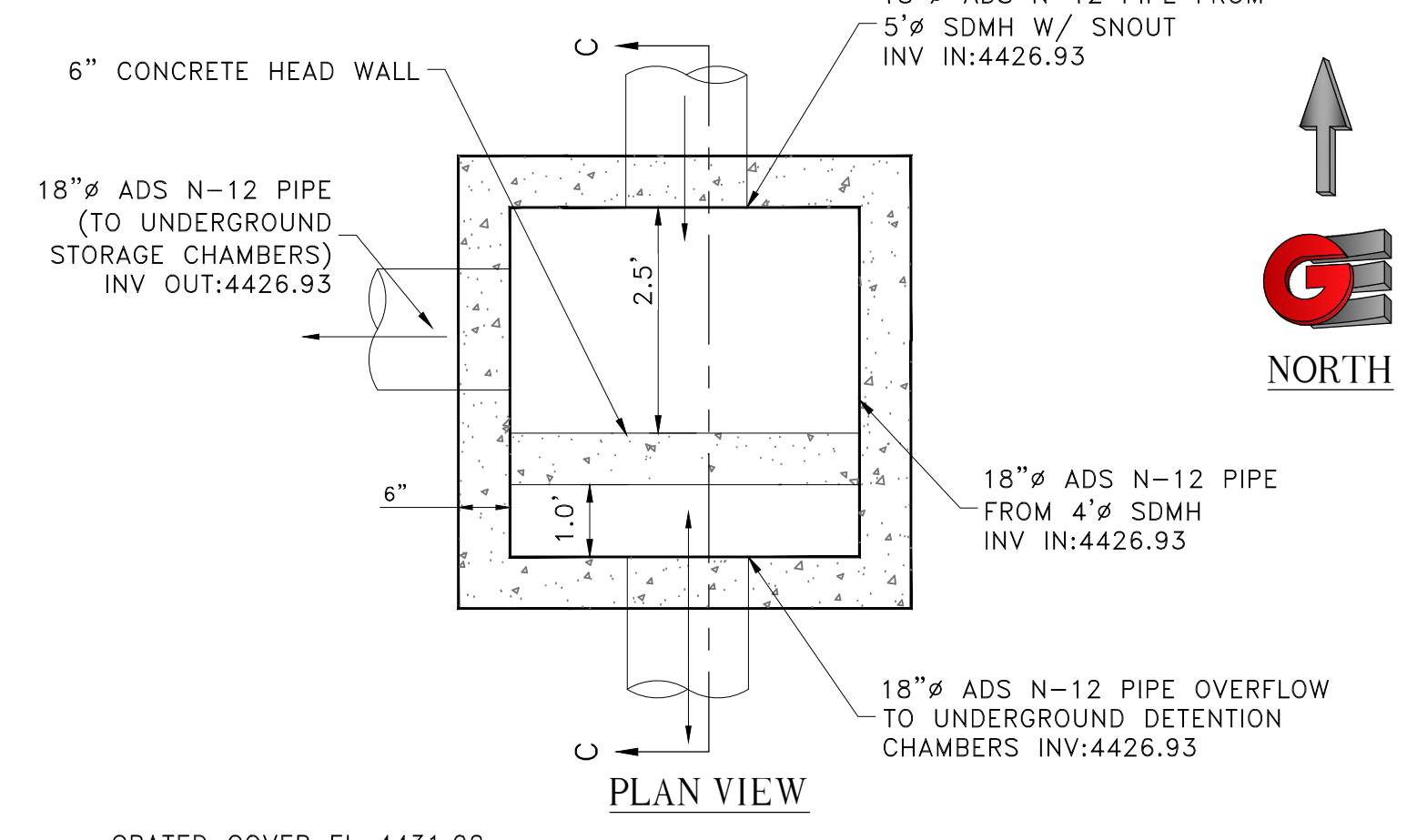
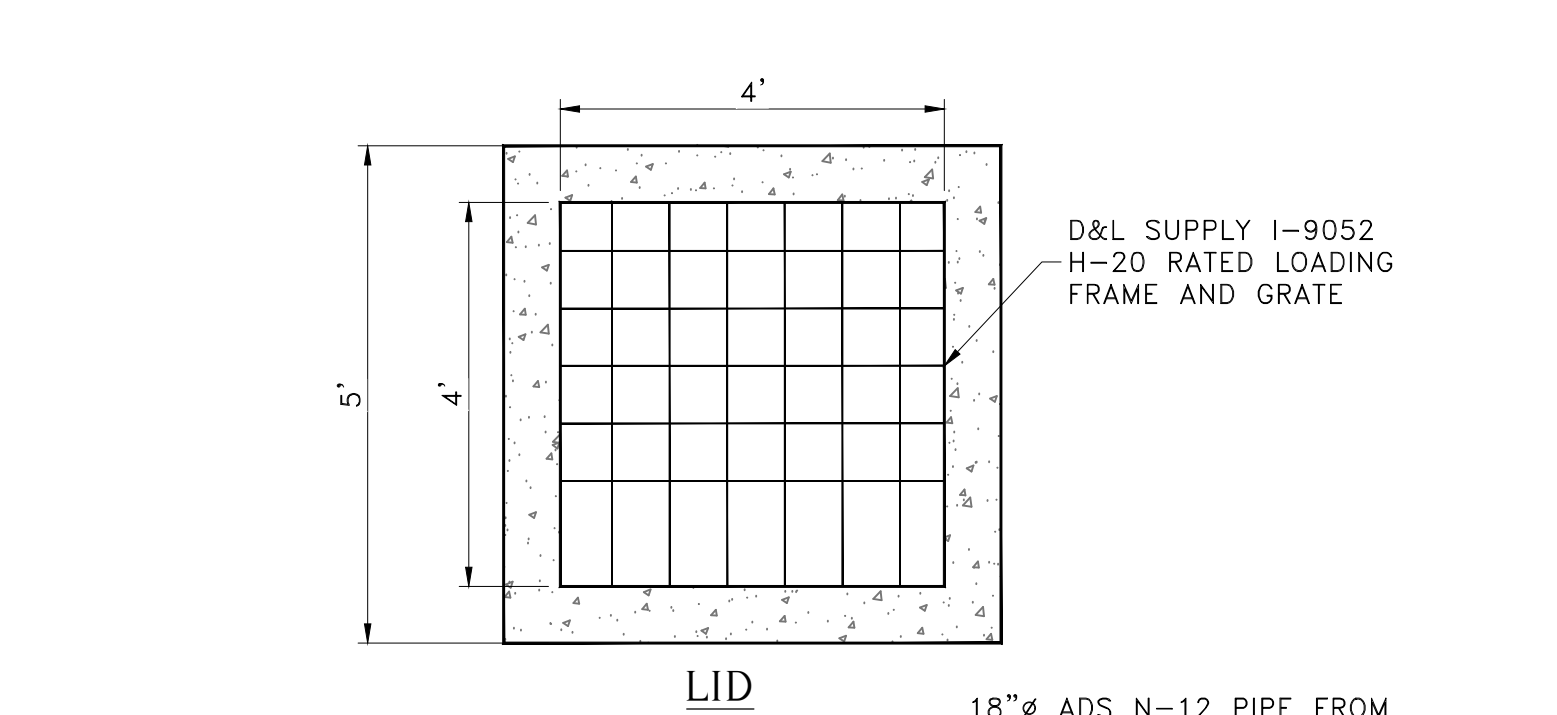

11 4' x 4' ISOLATION BAFFEL STORM DRAIN JUNCTION BOX
Scale: NTS

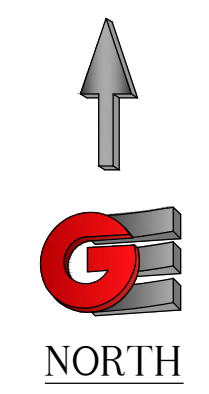

Section I 2016 Electric Service Requirements, 2nd Edition

1.11 Barrier Posts

Barrier posts shall be provided by the customer in locations where vehicular traffic may pose a threat to utility equipment.

See Figure 1 for details on barrier posts. Consult the Power Company regarding barrier post location prior to installation.

Requirements:

- Barrier posts shall be six-inch-diameter steel or concrete suitable for local environmental conditions.
- Steel posts may be filled with concrete.
- Posts shall have a domed top, free of burrs and sharp edges.
- Barrier posts shall be placed so as not to obstruct the opening of the equipment doors (doors shall open at least 135 degrees), nor to impede the operation of the equipment. If such positioning is not possible, removable posts shall be used in the obstructive location(s).
- Each barrier post shall be set in a concrete foundation at least 12 inches (12") in diameter and 24 inches (24") in depth below grade. See Figure 1 for additional space and dimension requirements.
- Enough barrier posts shall be installed to adequately protect utility equipment from damage.
- Temporary barrier posts may be required during construction.
- BARRIER POST MAY NOT BE INSTALLED WITHIN 3' OF AN EXISTING POWER POLE.

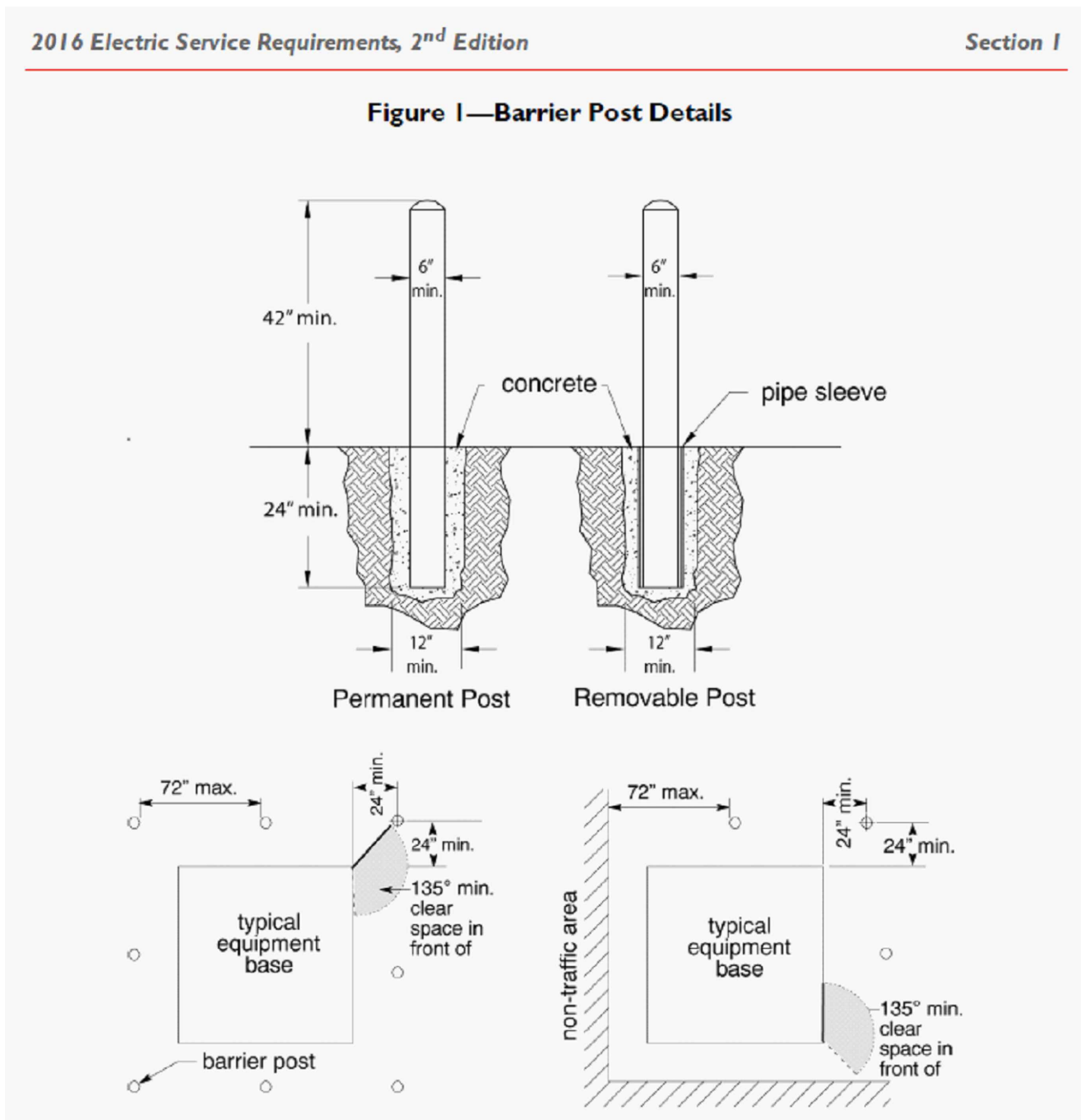

12 BARRIER POST DETAILS
Scale: (NOT TO SCALE)

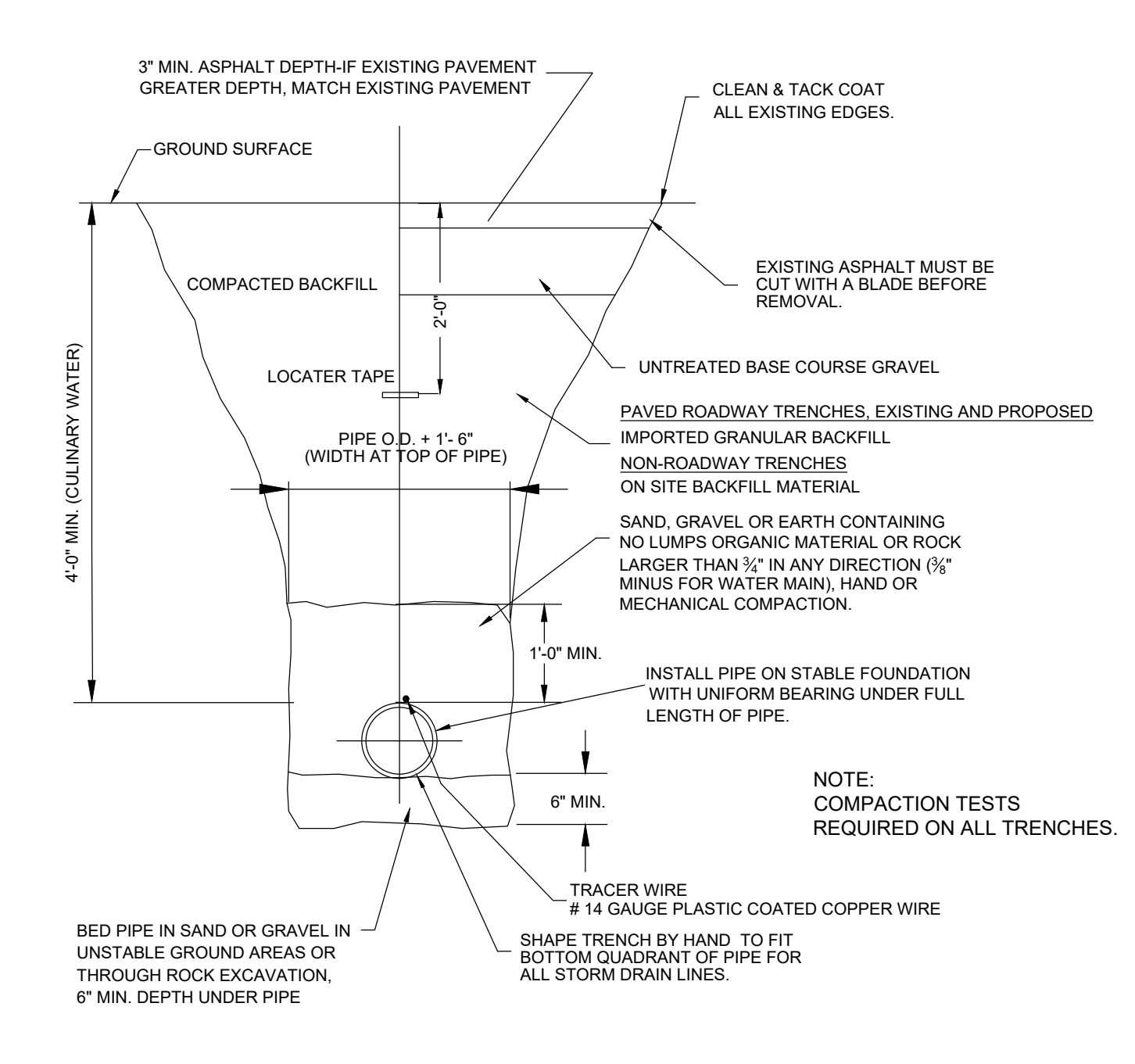

TYPICAL TRENCH DETAIL
Scale: (NOT TO SCALE)

SCALE: 1"=50'	DATE: 1/4/2023	DESIGN: WJS	DRAWN: WJS	CHECKED: TMN
REVISIONS	DESCRIPTION	DATE		

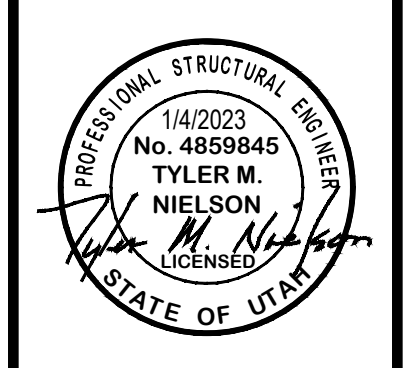

CIVIL UTILITY DETAILS
RV GENERAL
546 EAST OLD FORT ROAD
SOUTH WEBER CITY, DAVIS COUNTY, UTAH

GARDNER ENGINEERING
CIVIL-LAND PLANNING
MUNICIPAL-LAND SURVEYING
5150 SOUTH 375 EAST OGDEN, UT
OFFICE: 801-476-0202 FAX: 801-476-0066

CE5-05

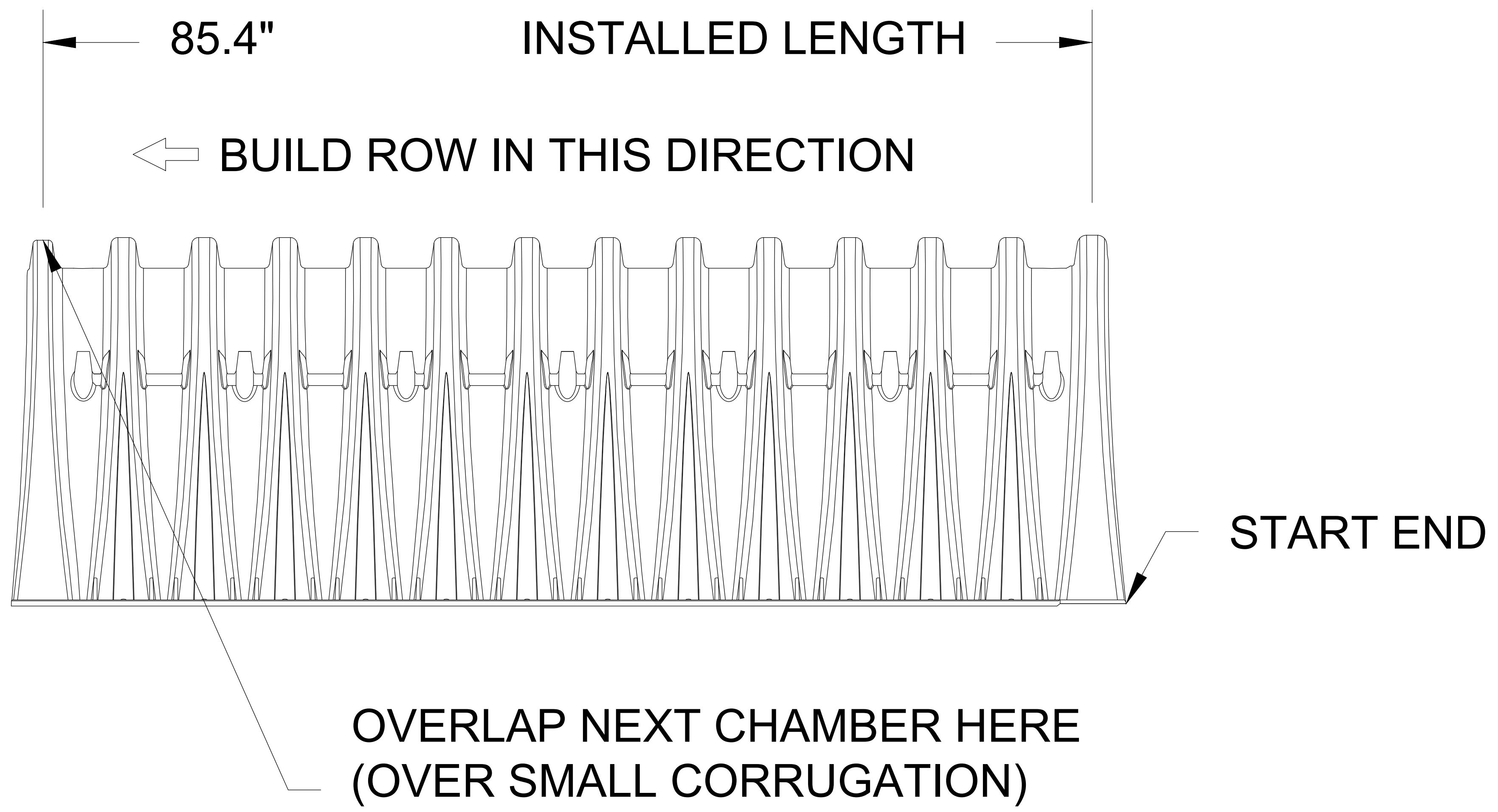

NOTE:
SEE MANUFACTURER INSTALLATION SPECIFICATIONS. REFER TO UTILITY SHEET FOR SPECIFIED GRAVEL DEPTHS BELOW AND ABOVE CHAMBERS.

13 CHAMBER SECTION DC-780 AND SC-740
Scale: NTS

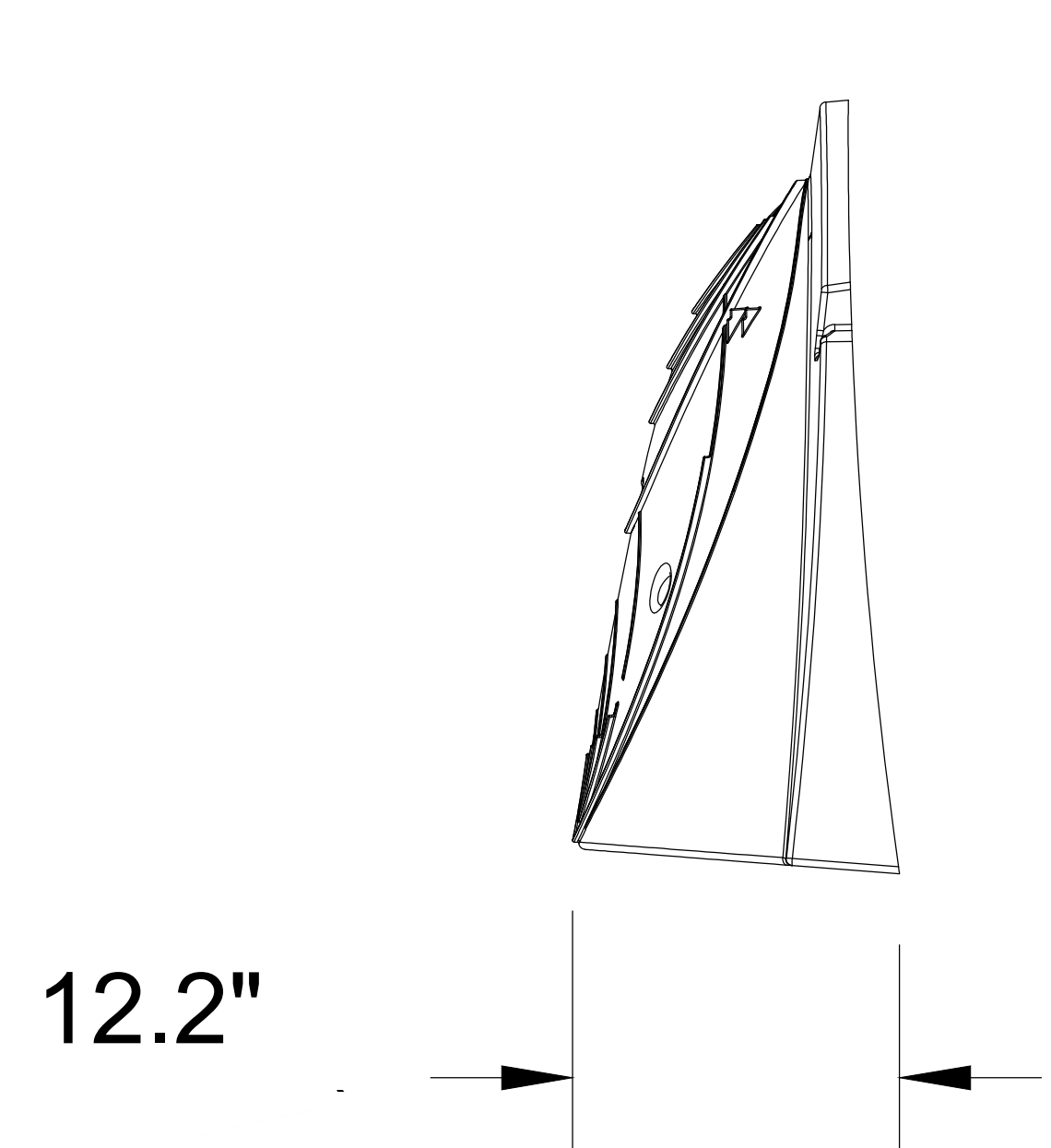

END SECTION
Scale: NTS

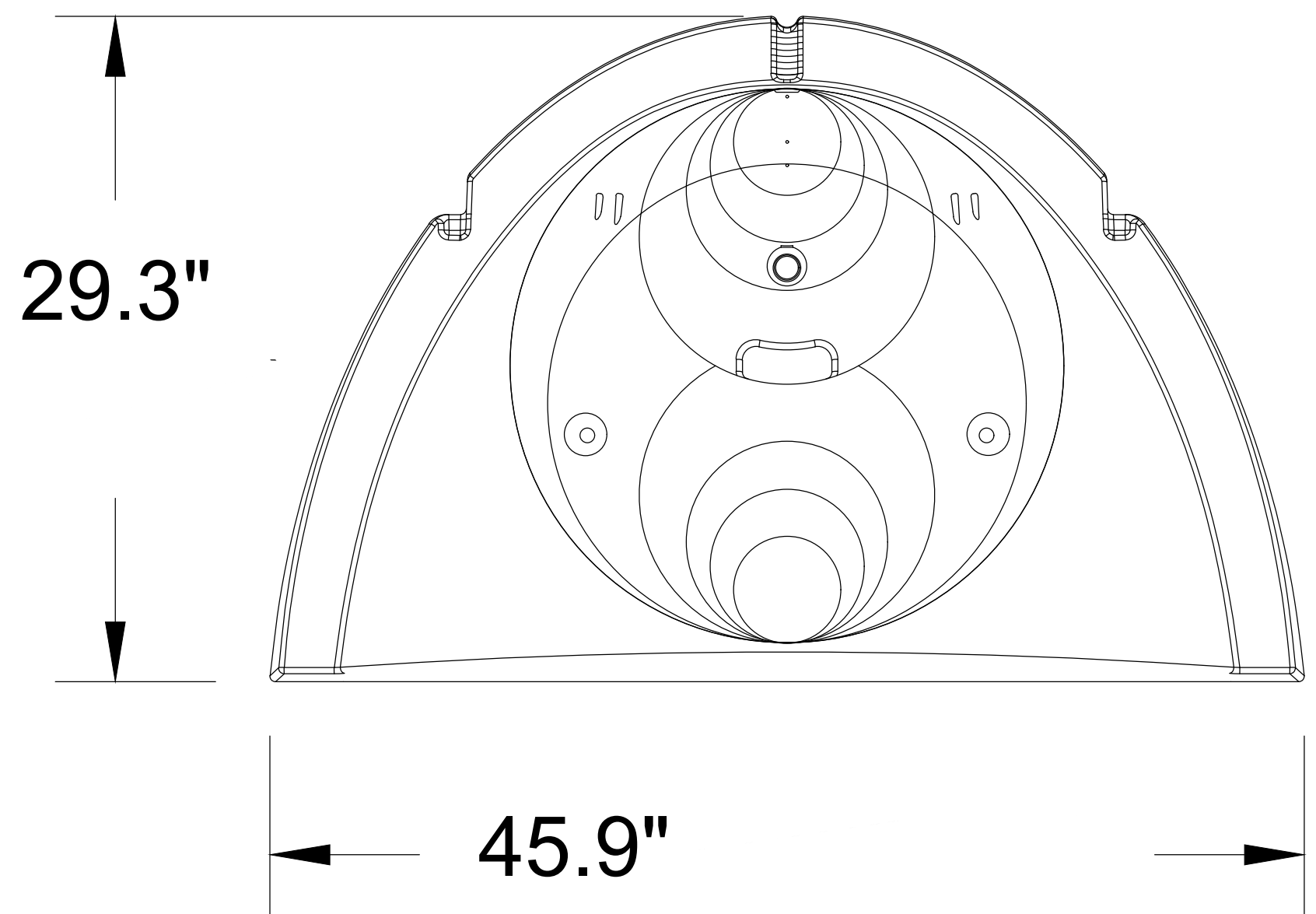

SCALE	1"=50'
DATE	1/4/2023
DESIGN	WJS
DRAWN	WJS
CHECKED	TJM
REVISIONS	DESCRIPTION
DATE	

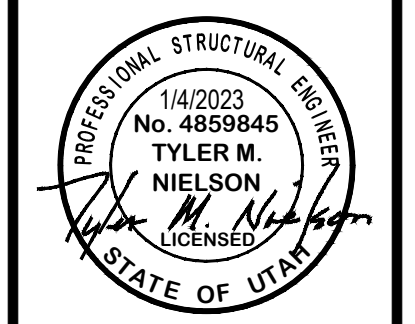

CIVIL UTILITY DETAILS
RV GENERAL
546 EAST OLD FORT ROAD
SOUTH WEBER CITY, DAVIS COUNTY, UTAH



CE5-06

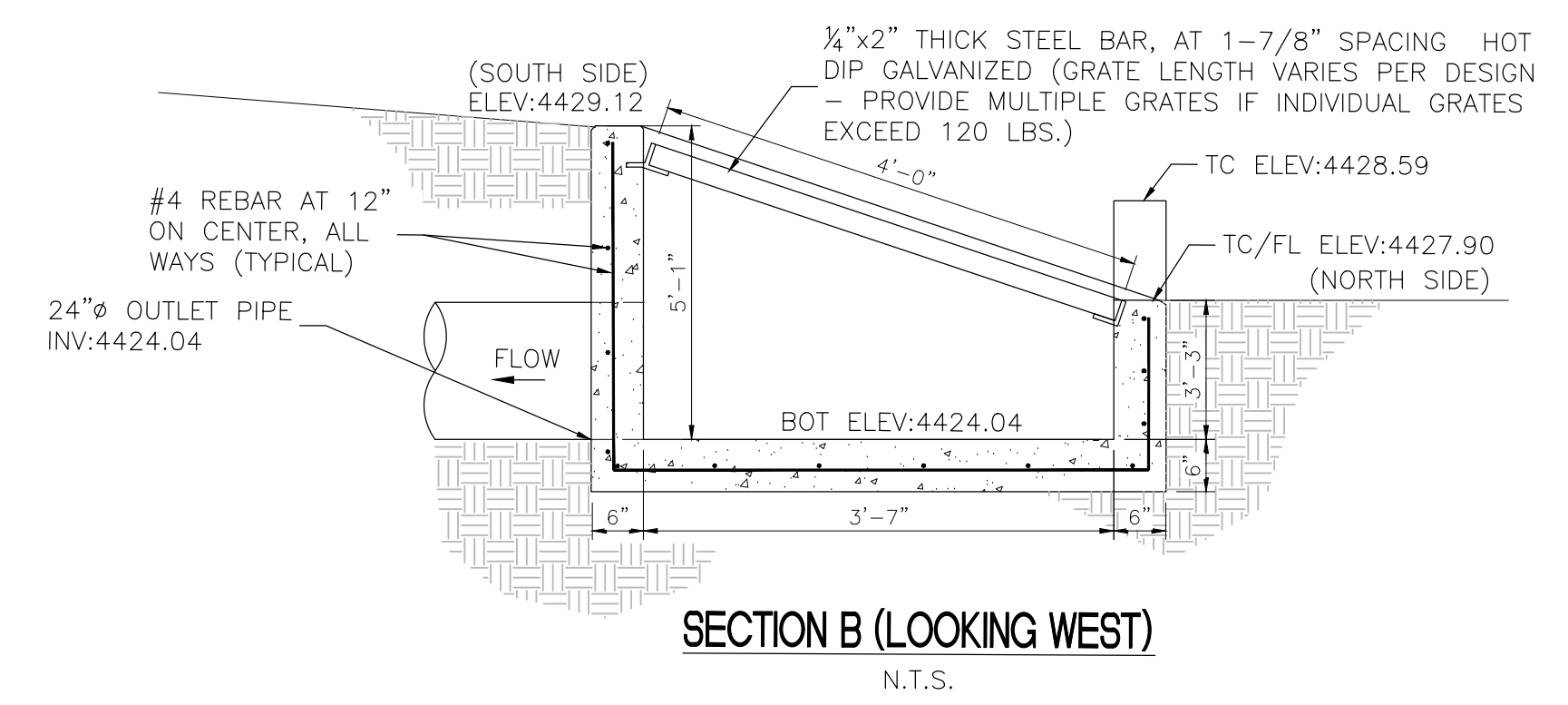
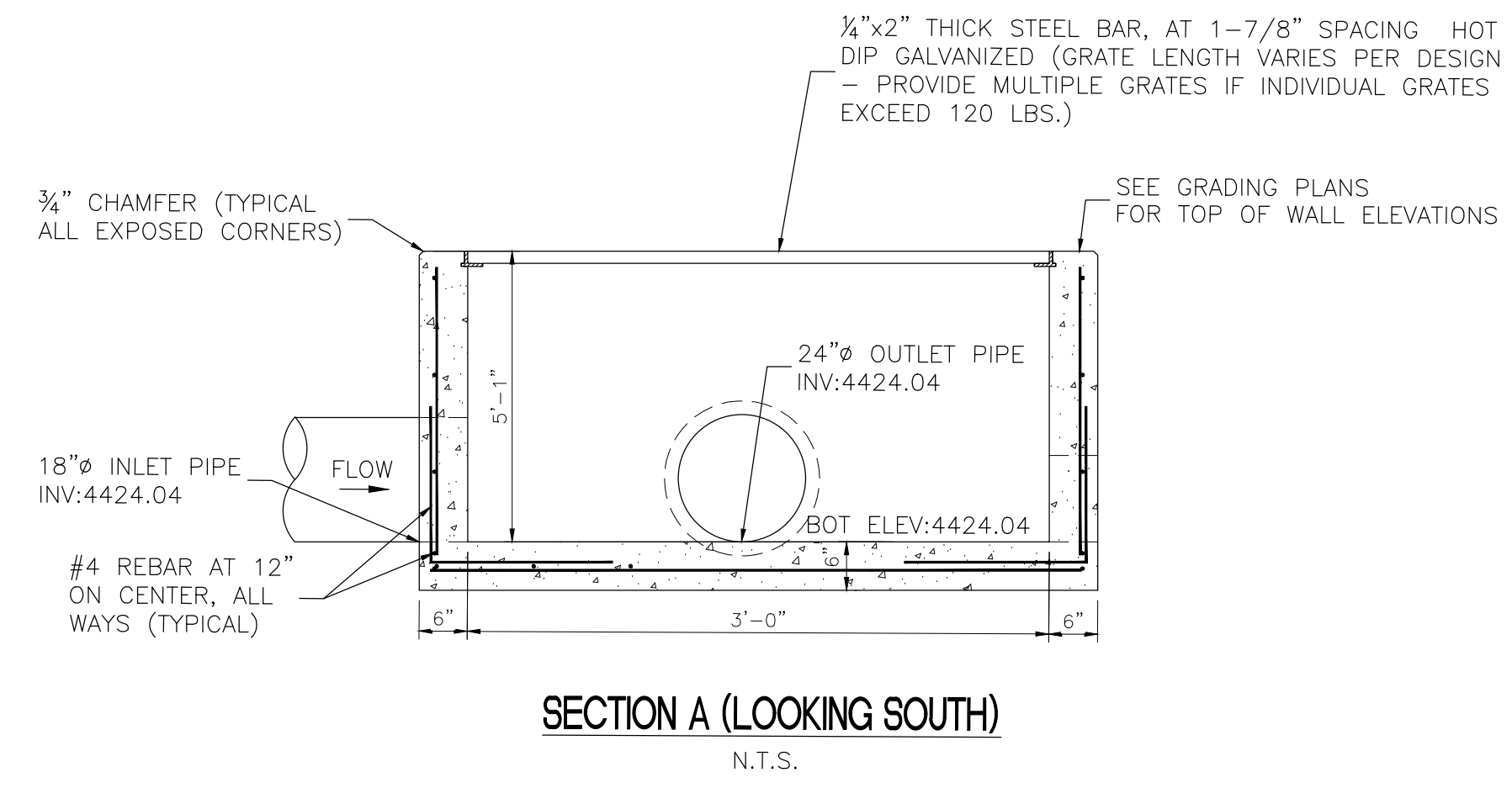
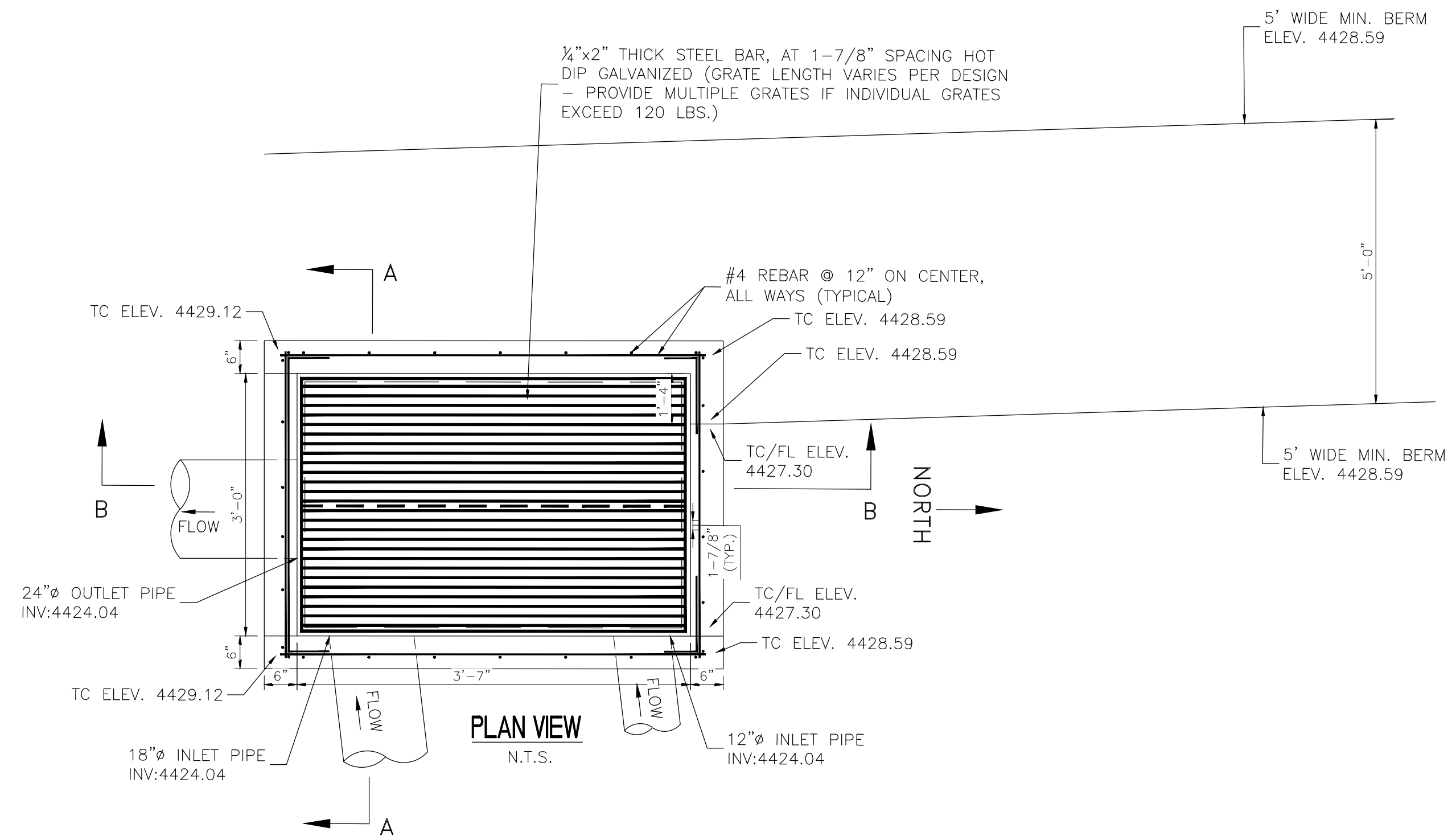

13 HEADWALL INLET STRUCTURE DETAIL
Scale: NTS

SCALE	1"=50'
DATE	1/4/2023
DESIGN	WJS
DRAWN	WJS
CHECKED	TJN
DWG.:	RV1102 - SOUTH WEBER LUG 2021 - GENERAL BY SOUTH WEBER/ISSA/CIVIL/STALLING

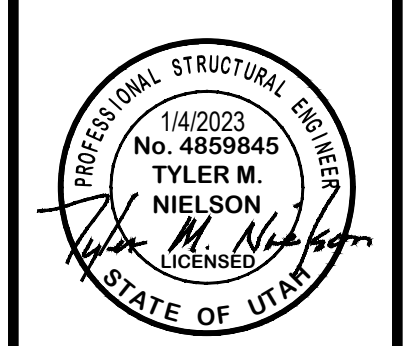

CIVIL UTILITY DETAILS
RV GENERAL
546 EAST OLD FORT ROAD
SOUTH WEBER CITY, DAVIS COUNTY, UTAH

GARDNER ENGINEERING
CIVIL • LAND PLANNING
MUNICIPAL • LAND SURVEYING
5150 SOUTH 375 EAST OGDEN, UT
OFFICE: 801.476.0202 FAX: 801.476.0066

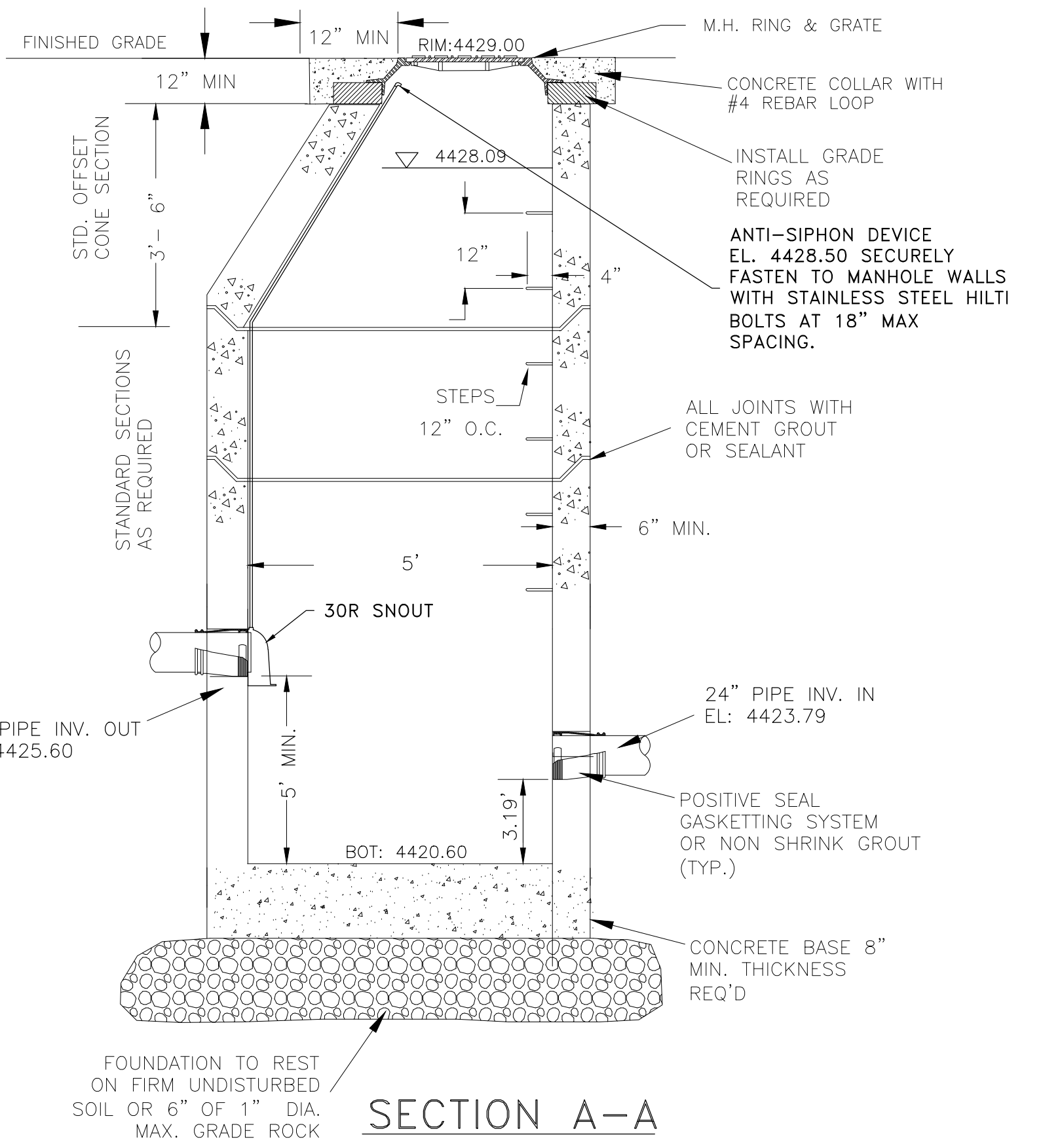
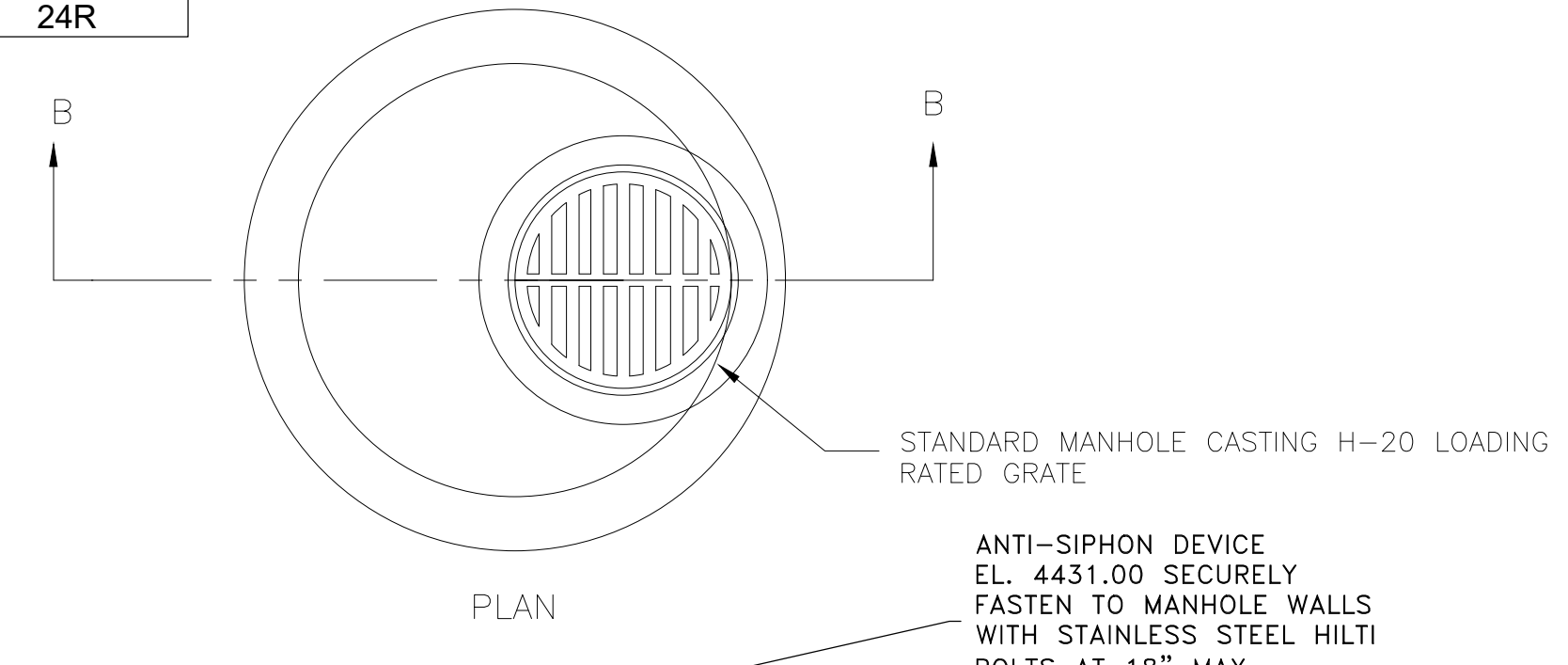
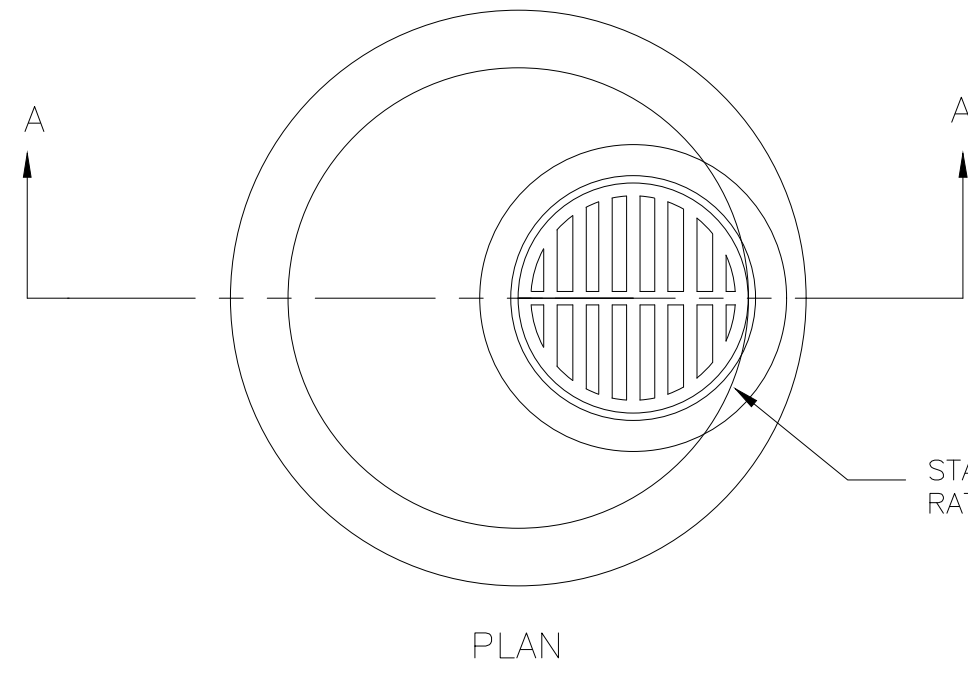
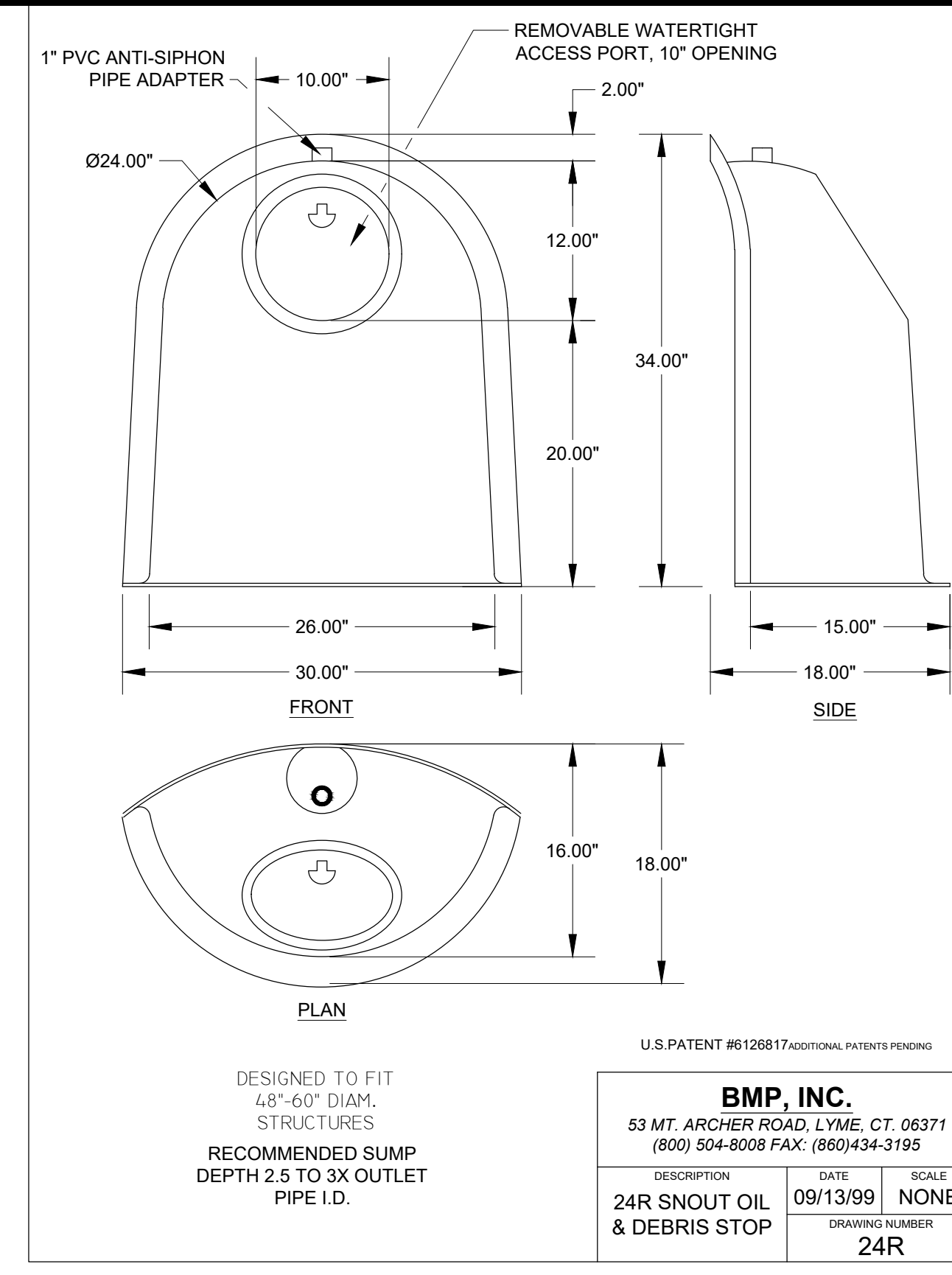
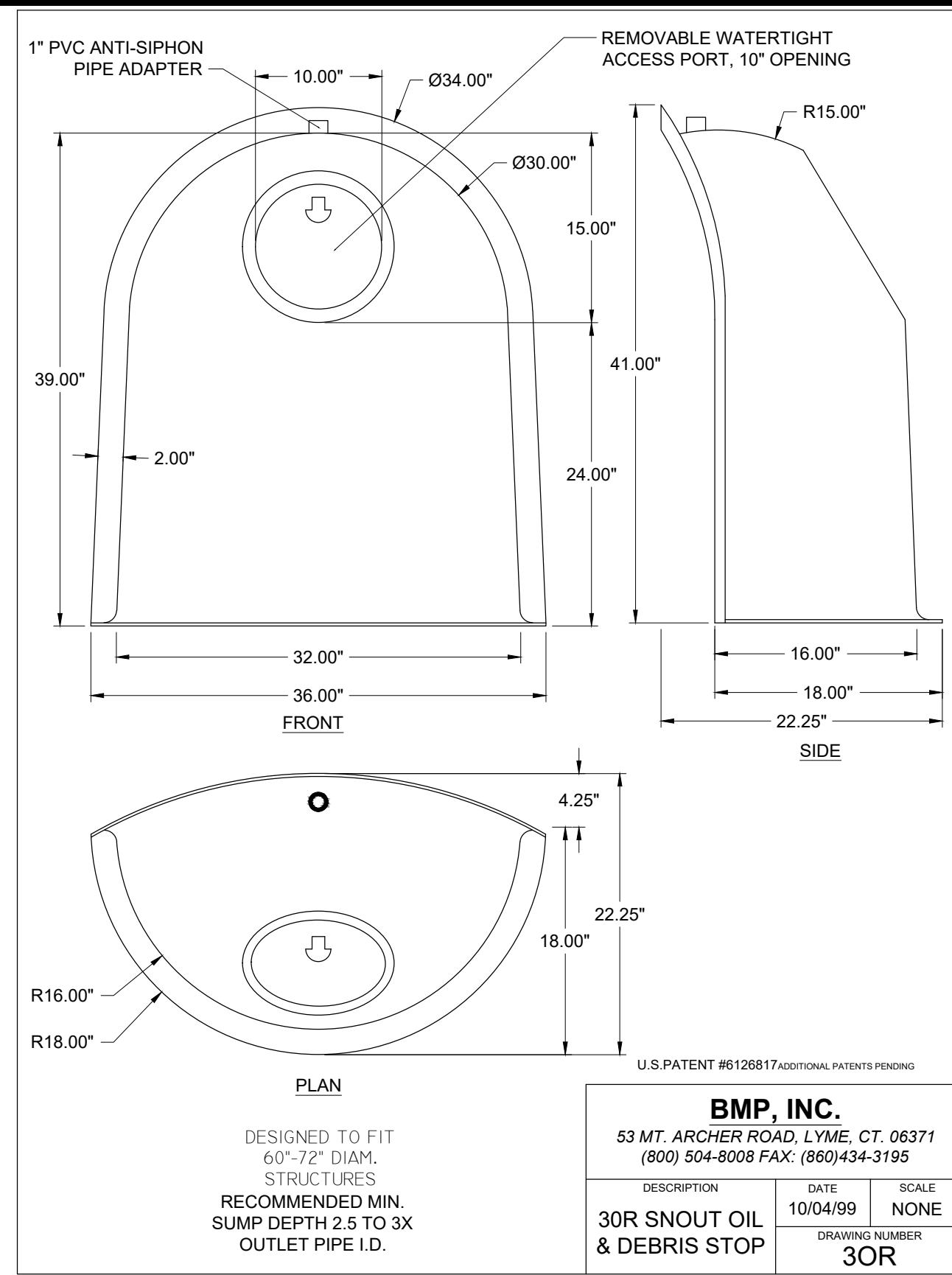

14 STORM DRAIN MANHOLE W/ 30R SNOOT
Scale: (NOT TO SCALE)

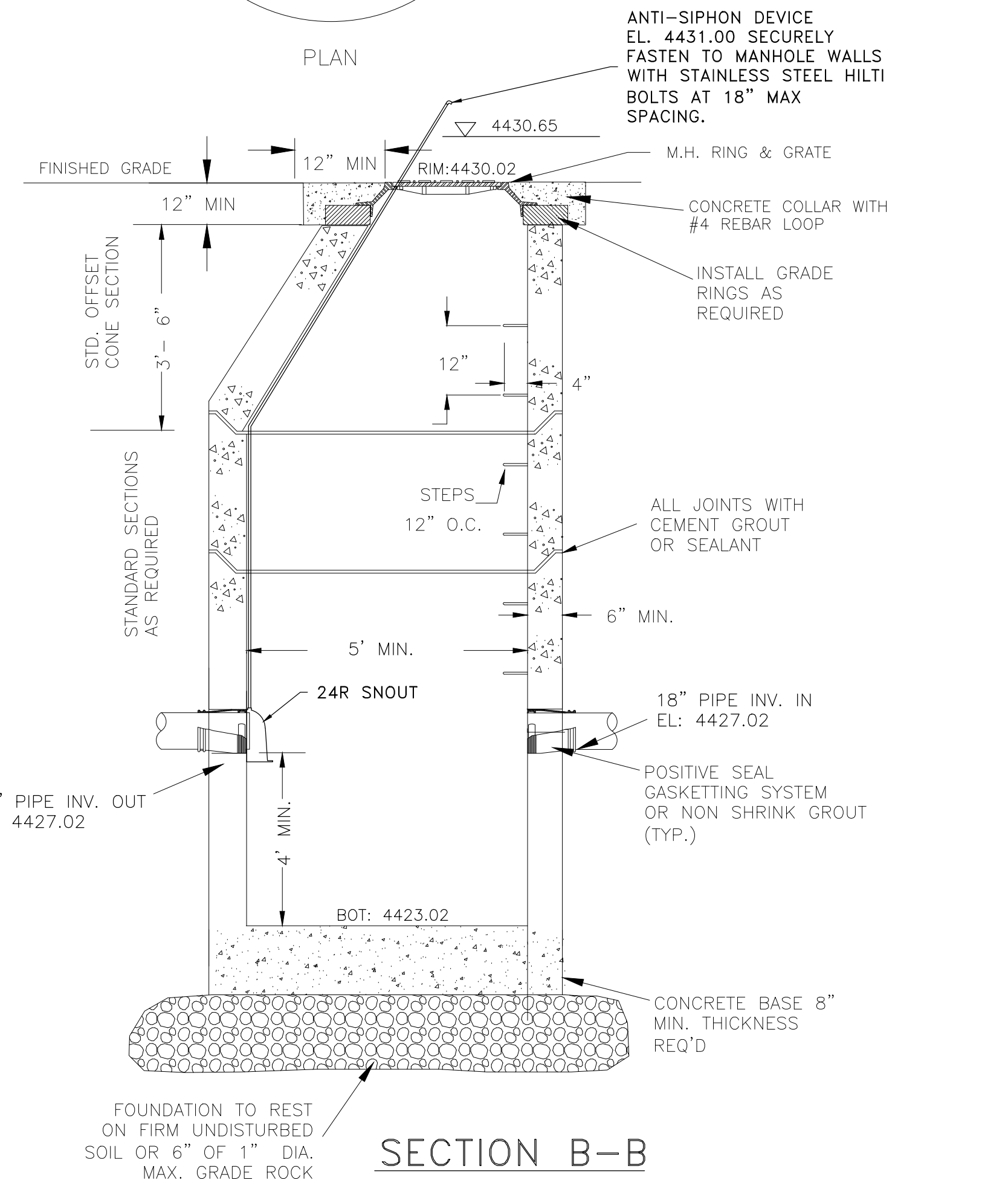
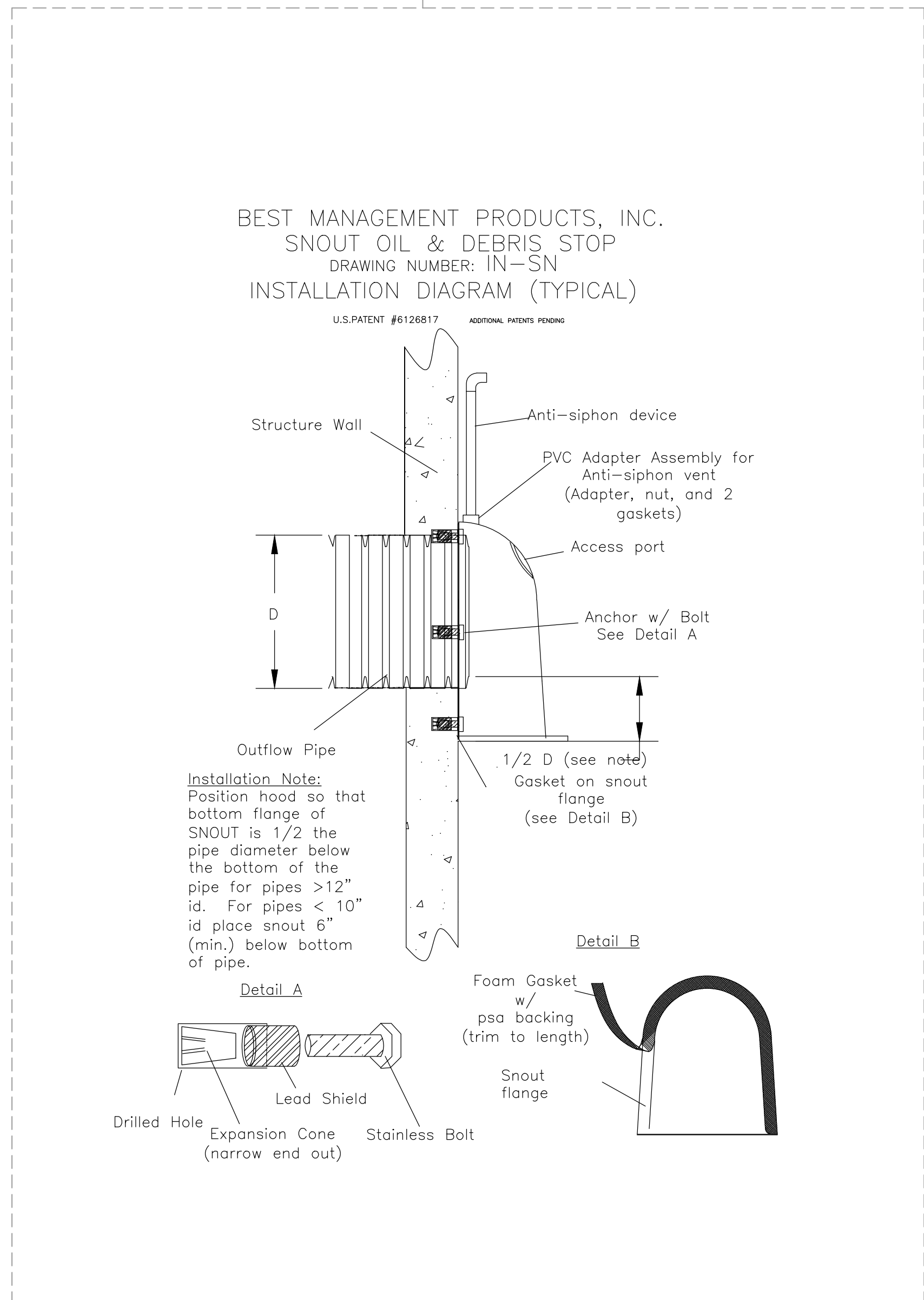

15 STORM DRAIN MANHOLE W/ 24R SNOOT
Scale: (NOT TO SCALE)

SCALE	1"=50'
DATE	1/4/2023
DESIGN	WJS
DRAWN	WJS
CHECKED	TJM
REVISIONS	DESCRIPTION
DATE	

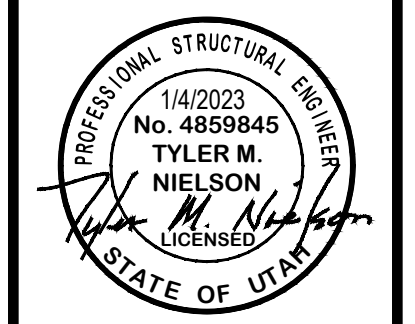

CIVIL UTILITY DETAILS
RV GENERAL
546 EAST OLD FORT ROAD
SOUTH WEBER CITY, DAVIS COUNTY, UTAH



CE5-08

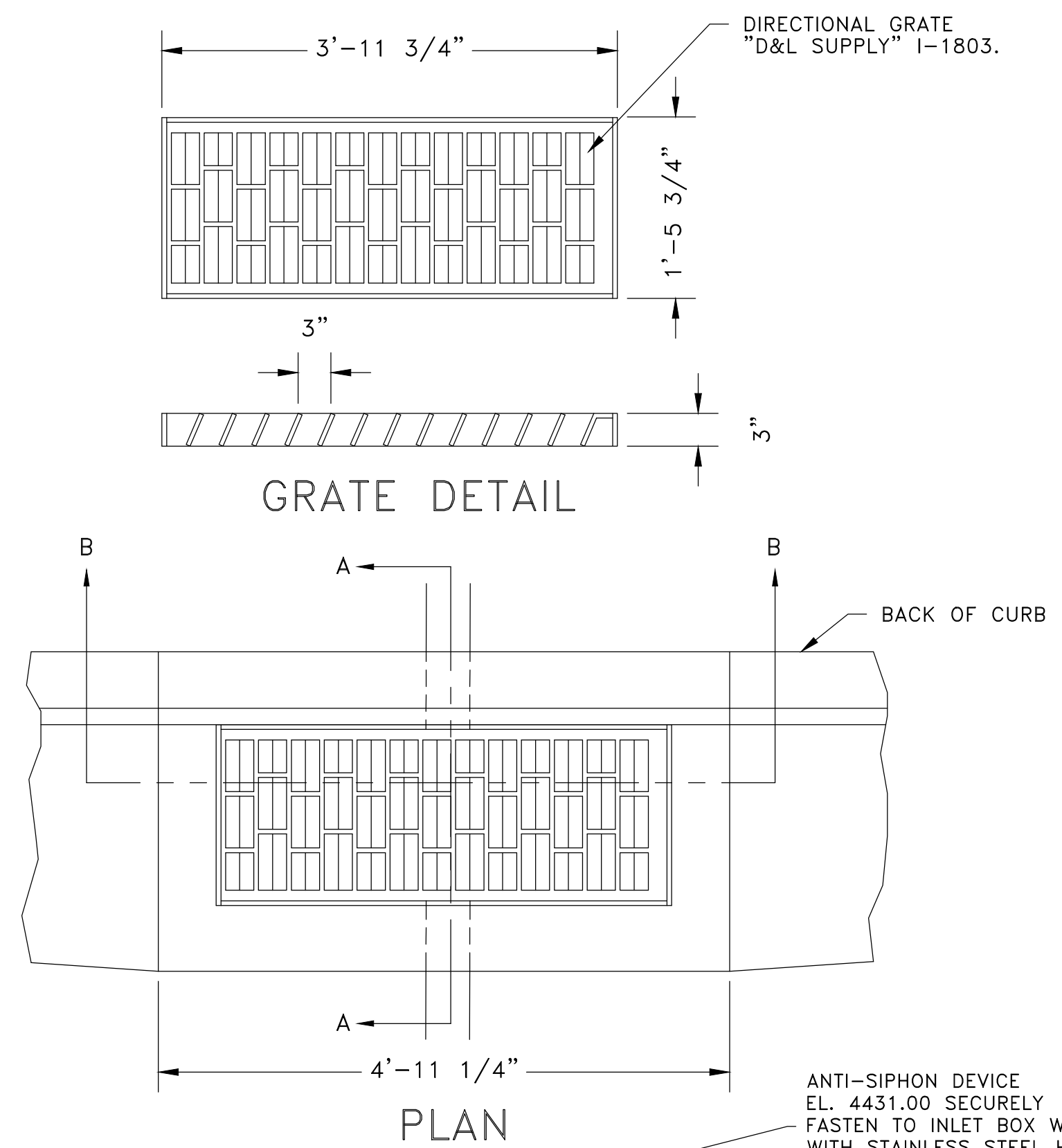

16 18-INCH CURB INLET BOX W/ 18F SNOOUT
Scale: (NOT TO SCALE)

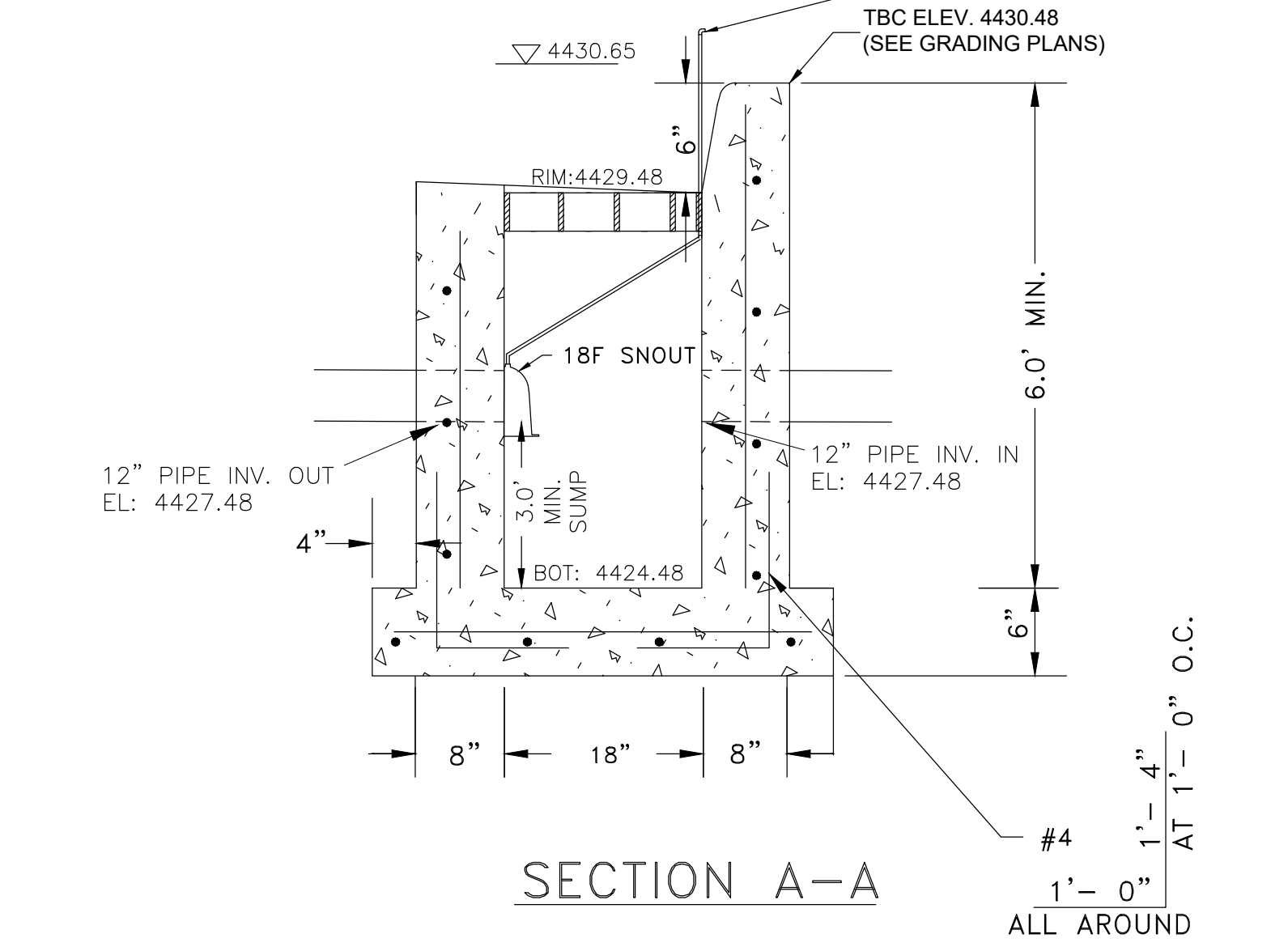

SECTION A-A

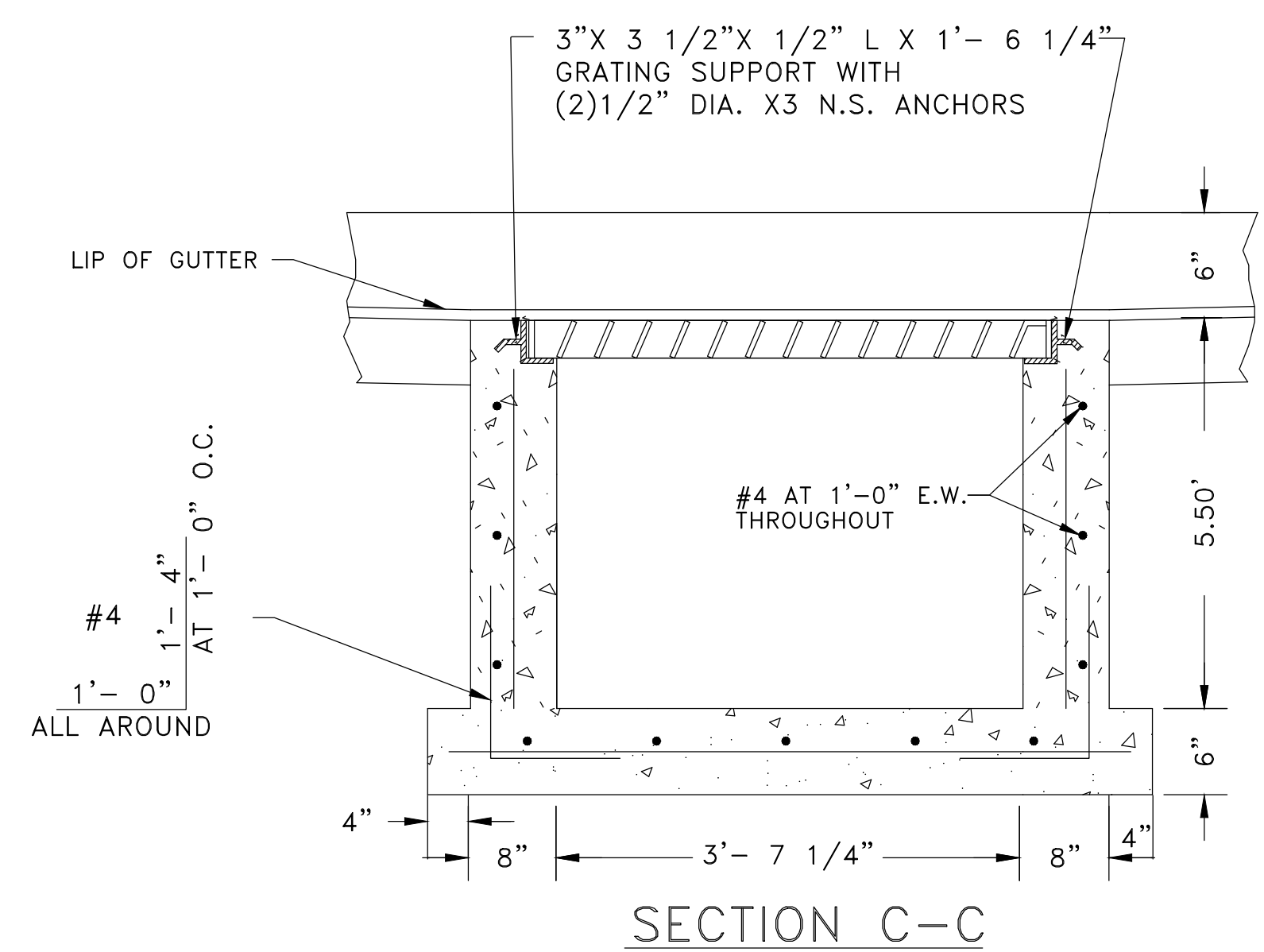

SECTION C-C

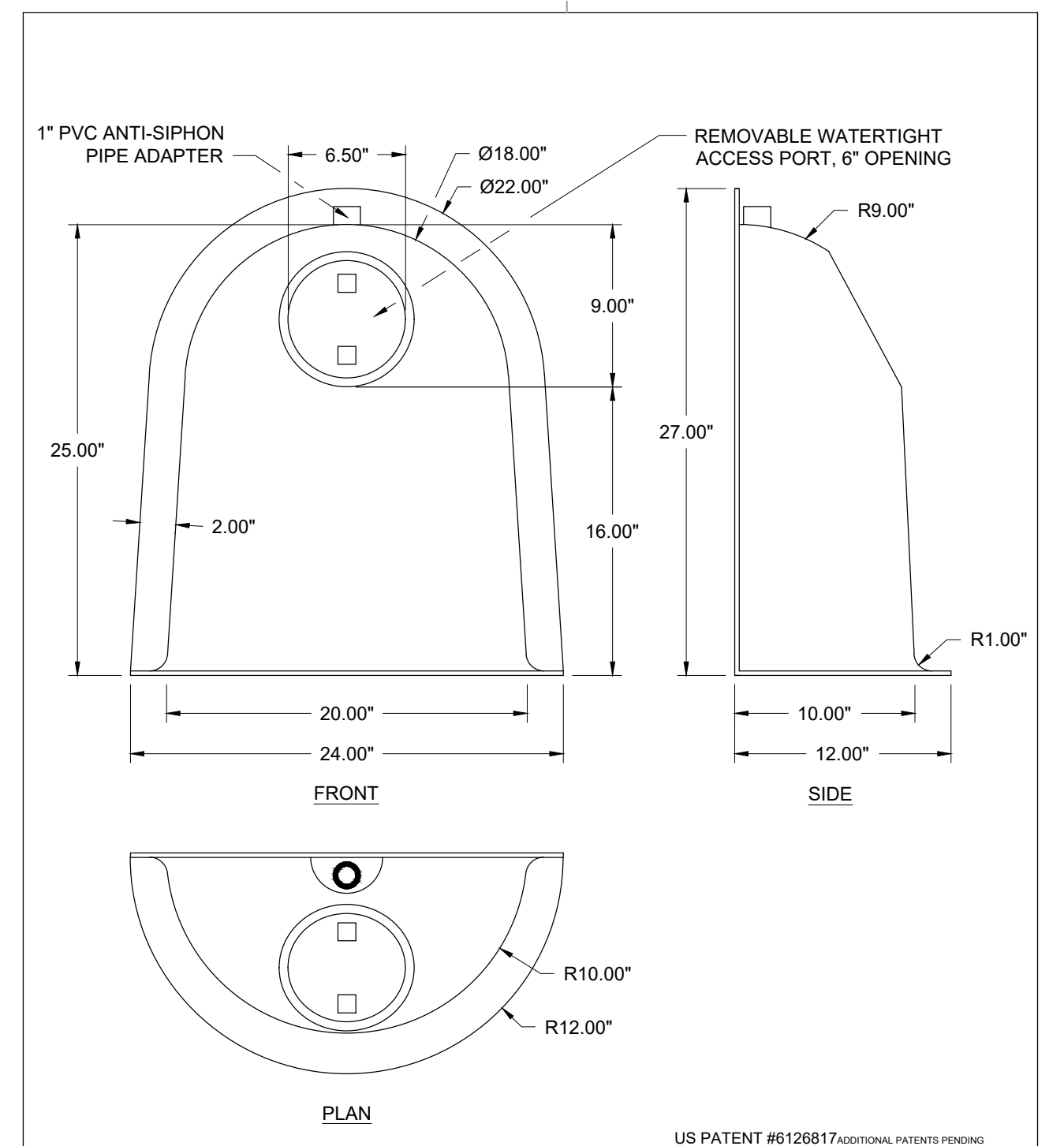

US PATENT #6126817 ADDITIONAL PATENTS PENDING

BMP, INC.
53 MT. ARCHER ROAD, LYME, CT. 06371
(800) 504-8008 FAX: (860) 434-3195

DESCRIPTION:	DATE:	SCALE:
18F SNOOUT OIL & DEBRIS STOP	09/14/99	NONE
DRAWING NUMBER:		
18F		

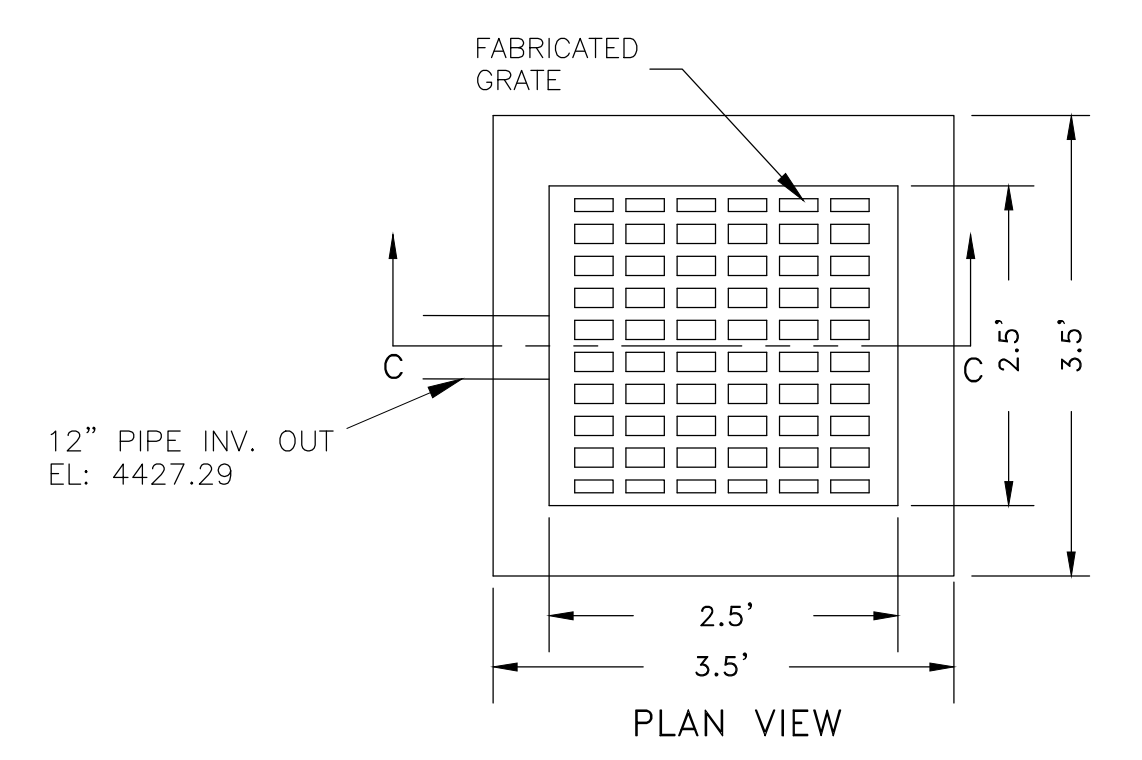

PLAN VIEW

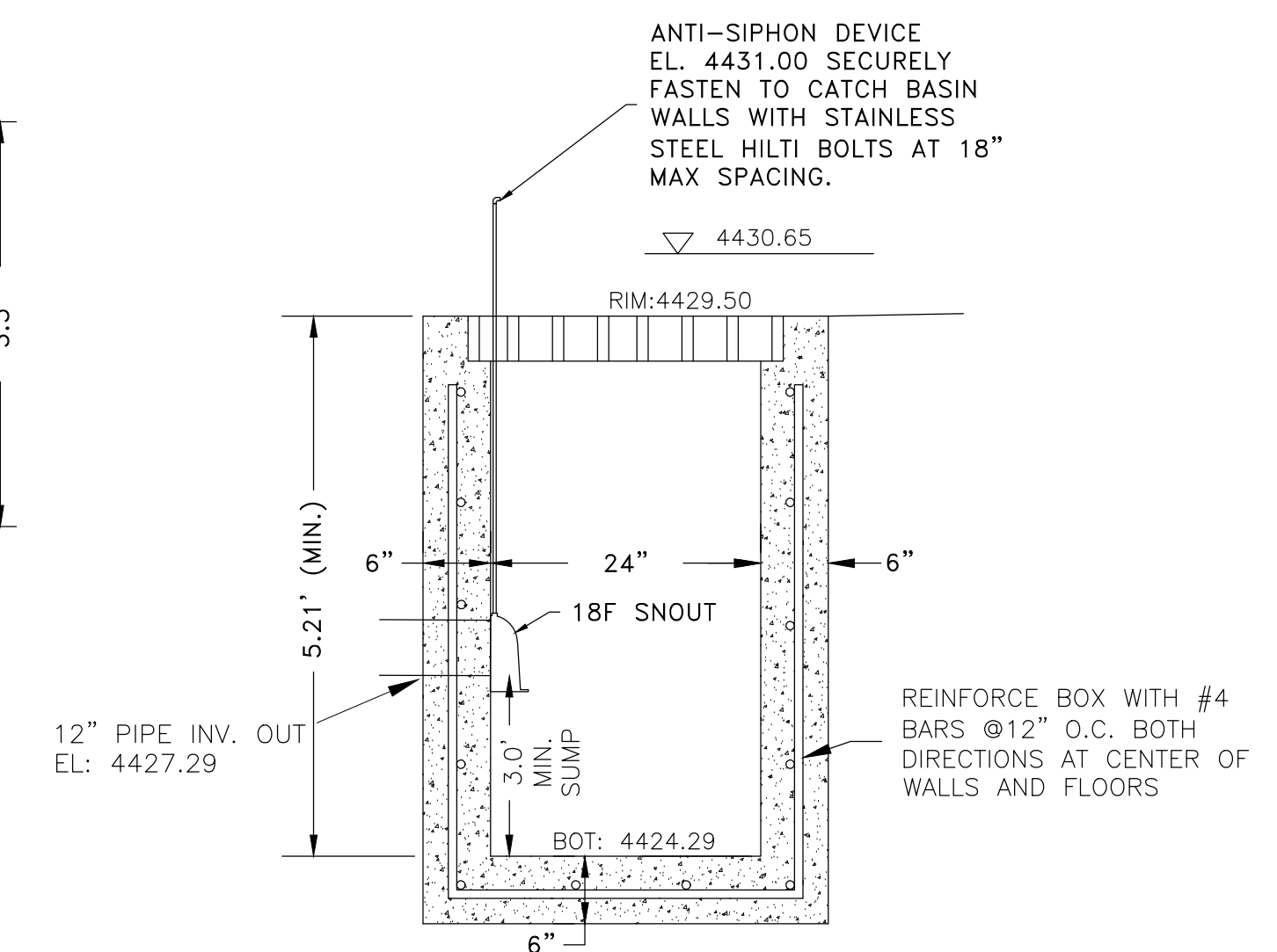

SECTION C-C

17 24-INCH CATCH BASIN W/ 18F SNOOUT
Scale: (NOT TO SCALE)

BEST MANAGEMENT PRODUCTS, INC.
SNOOUT OIL & DEBRIS STOP
DRAWING NUMBER: IN-SN
INSTALLATION DIAGRAM (TYPICAL)

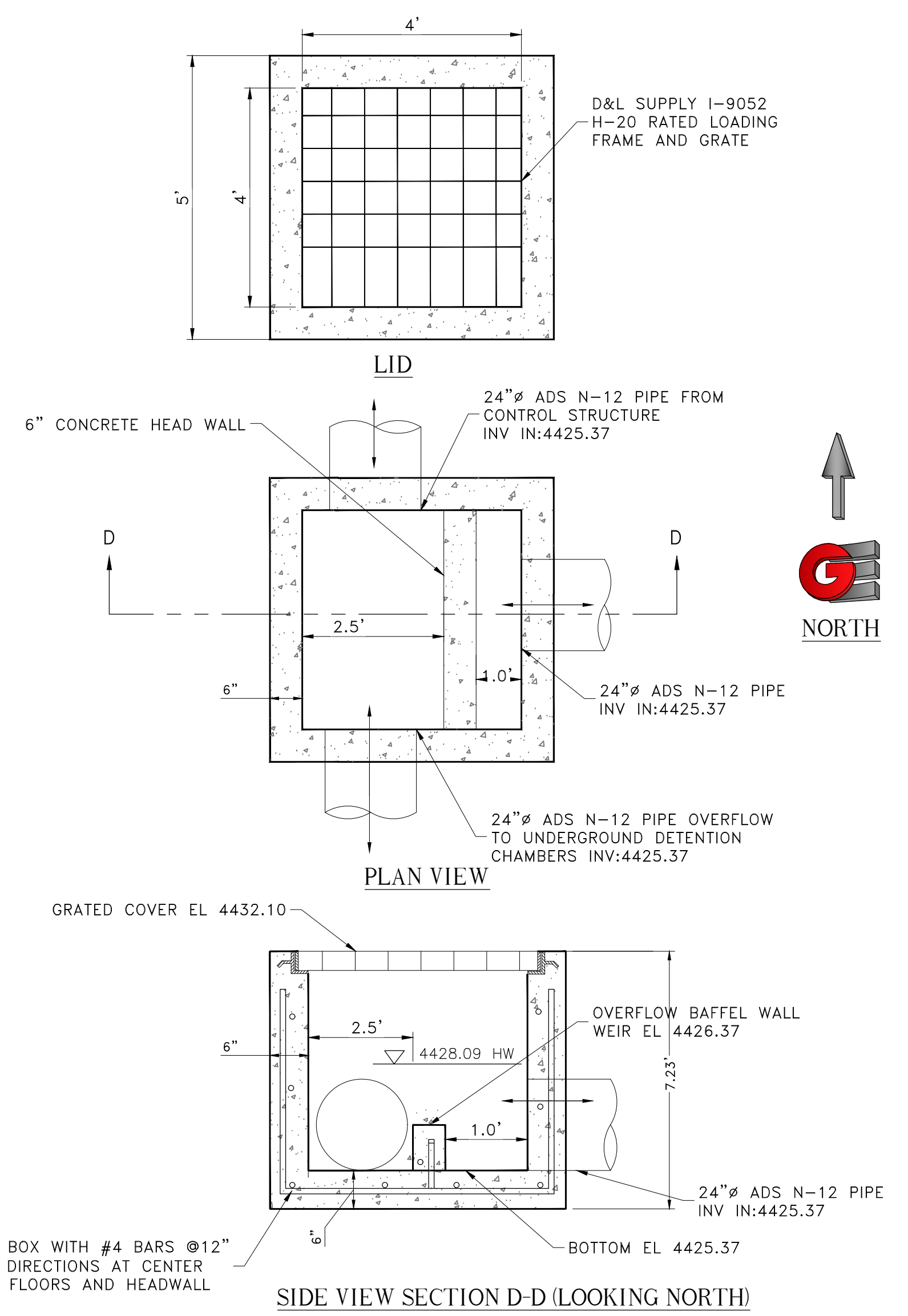
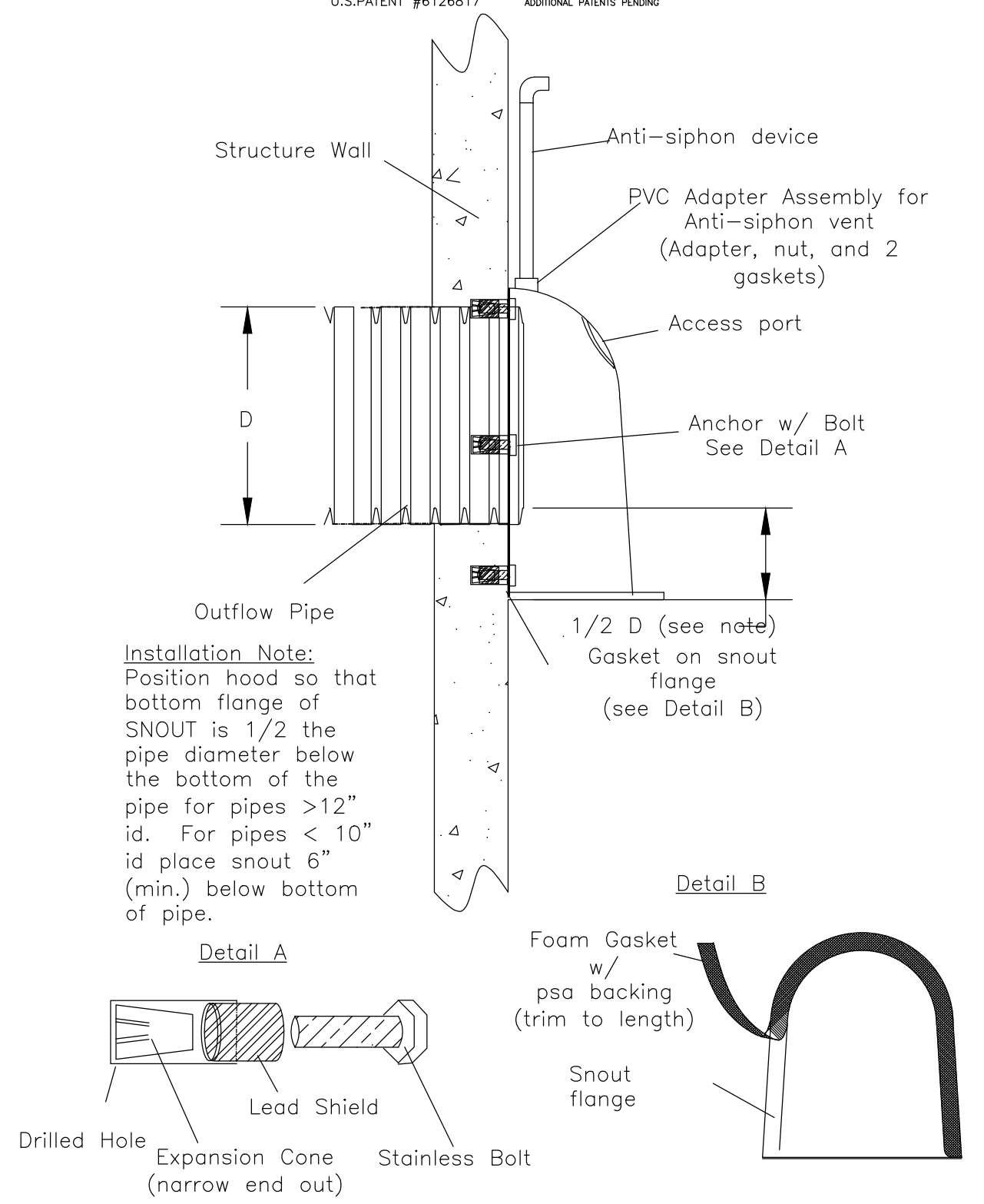

PLAN VIEW

SIDE VIEW SECTION D-D (LOOKING NORTH)

18 4' x 4' ISOLATION BAFFEL STORM DRAIN JUNCTION BOX
Scale: NTS

SCALE: 1"=5'	DATE: 1/4/2023	DESIGN: WJS	DRAWN: WJS	CHECKED: TMN
REVISIONS	DESCRIPTION	DATE		

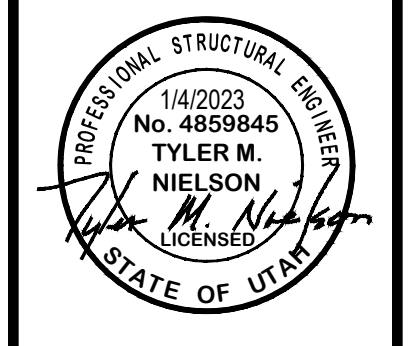

CIVIL UTILITY DETAILS
RV GENERAL
546 EAST OLD FORT ROAD
SOUTH WEBER CITY, DAVIS COUNTY, UTAH

GARDNER ENGINEERING
CIVIL-LAND PLANNING
MUNICIPAL-LAND SURVEYING
5150 SOUTH 375 EAST OGDEN, UT
OFFICE: 801-476-0202 FAX: 801-476-0066

CE5-09

DETECTABLE WARNING SURFACE NOTES:

1. LOCATE THE DETECTABLE WARNING SURFACE SO THE OUTSIDE CORNER NEAREST THE STREET IS WITHIN 1 INCH OF THE BACK OF CURB (TBC). PROVIDE 2'-FOOT MINIMUM DEPTH.
2. PROVIDE DETECTABLE WARNING SURFACE FOR FULL WIDTH OF CURB CUT.
3. THE DETECTABLE WARNING SURFACE DOMES SHALL BE ORIENTED SUCH THAT THE ROWS ARE PARALLEL WITH THE DIRECTION OF PEDESTRIAN TRAVEL TO THE RAMP ON THE OPPOSITE SIDE OF THE STREET.
4. THE STANDARD COLOR FOR THE DETECTABLE WARNING SURFACE SHALL BE YELLOW OR PRE-APPROVED CONTRASTING COLOR. WHEN THE EXISTING SIDEWALK COLOR IS NOT STANDARD CONCRETE, THE COLOR OF THE DETECTABLE WARNING SURFACE SHALL BE DETERMINED BY THE CITY ENGINEER OR AUTHORIZED REPRESENTATIVE.
5. WHEN A DETECTABLE WARNING SURFACE DOME IS CUT, THE REMAINING PORTION OF THE DOME SHALL BE BEVELED TO A MAXIMUM SLOPE OF 1:2.

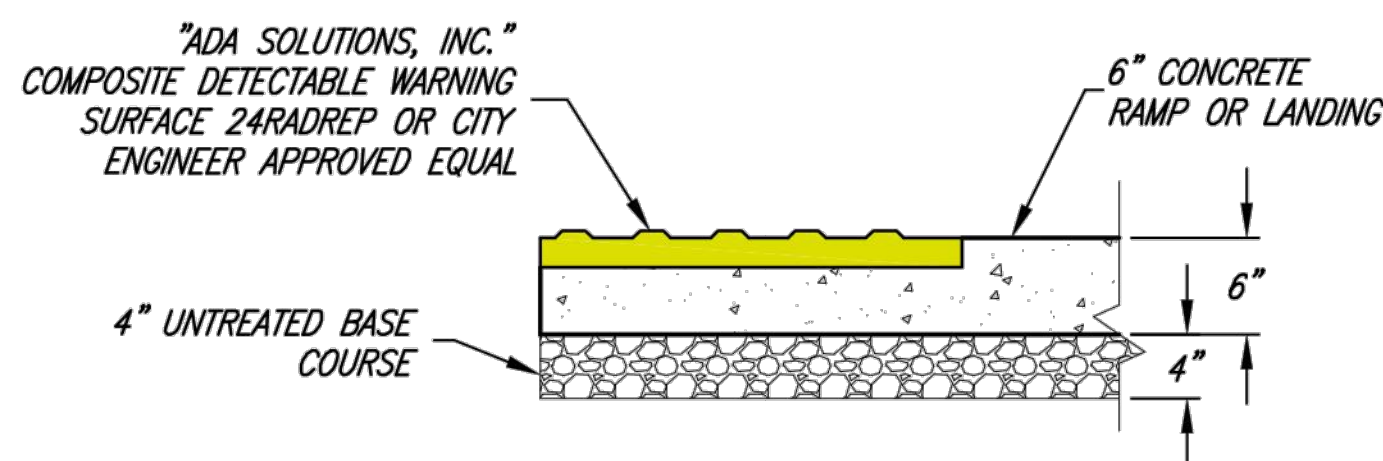

DETECTABLE WARNING SURFACE DETAIL

ADA RAMP NOTES:

- A. WHERE DESIGNATED BY THE CITY, ALTERNATE UDOT OR APWA RAMP DESIGNS MAY BE USED WITH THE PRIOR APPROVAL OF THE CITY ENGINEER AND THE CITY PUBLIC WORKS DEPARTMENT. SUBMIT ENGINEERED CONSTRUCTION PLANS TO CITY ENGINEER FOR REVIEW AND ACCEPTANCE PRIOR TO CONSTRUCTION.
- B. SITE CONDITIONS WILL VARY. CONFIGURATION OF RAMP, LANDING, AND TRANSITION MAY BE CHANGED, BUT THEY MUST MEET DIMENSIONS AND SLOPES AS SHOWN IN THE MOST RECENT EDITION OF THE U.D.O.T. STANDARDS & SPECIFICATIONS (SHEETS PA1 THROUGH PA5). THE USE OF FLARES, CURB WALLS, ETC. ARE AT THE DISCRETION OF THE ENGINEER.
- C. LOCATE CURB CUT WITHIN CROSSWALK.
- D. RAMP GRADE BREAK MUST BE PERPENDICULAR TO THE RUNNING SLOPE.

SLOPE TABLE			
ITEM	MAX RUNNING SLOPE*	MAX. CROSS SLOPE*	
T	TURNING SPACE ²	2% (1V:48H)	2% (1V:48H)
R	RAMP	8.3% (1V:12H)	2% (1V:48H)
S	SIDEWALK	5% (1:20) ¹	2% (1V:48H)
F1	TRAVERSABLE SURFACE	10% (1V:10H)	--
F2	NON-TRAVERSABLE SURFACE	25% (1V:4H)	--
B	BLENDED TRANSITION	5% (1V:20H) 2% MIN.	2% (1V:48H)

* RUNNING SLOPE IS IN THE DIRECTION OF PEDESTRIAN TRAVEL. CROSS SLOPE IS PERPENDICULAR TO PEDESTRIAN TRAVEL.

¹ 5% MAX OR NATURAL SLOPE OF LAND

² NOT TO EXCEED 2% IN ANY DIRECTION

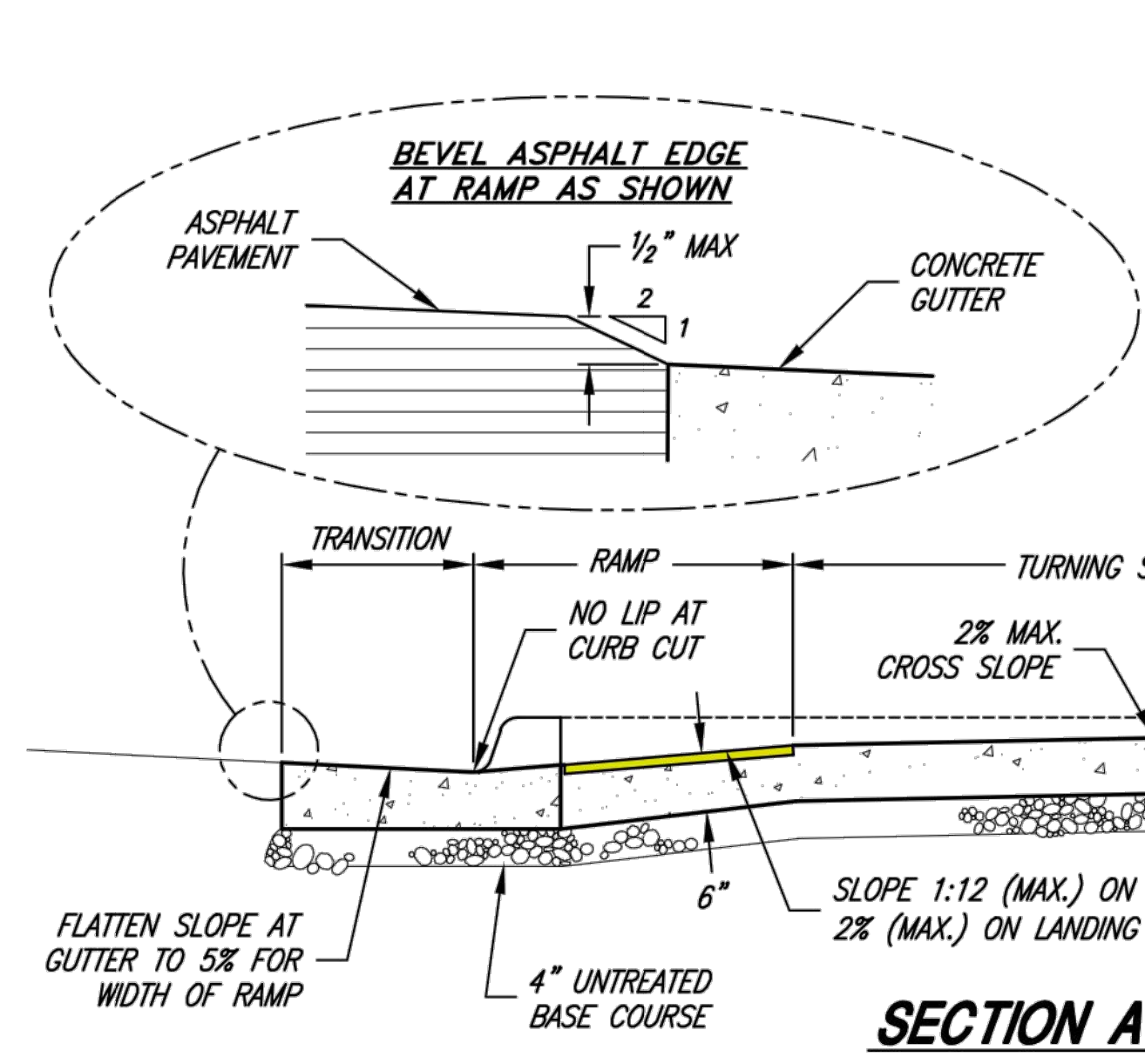

SECTION A-A

GENERAL NOTES:

- A2. INSTALLATION TOLERANCES ON CURB & GUTTER AND SIDEWALK PER APWA 32 16 1.3, 3.7.
- B2. AS-BUILT SURVEY MAY BE REQUIRED TO VERIFY COMPLIANCE WITH TOLERANCES.
- C2. GRINDING OF CONCRETE, TO MEET TOLERANCES, WILL NOT BE ALLOWED.

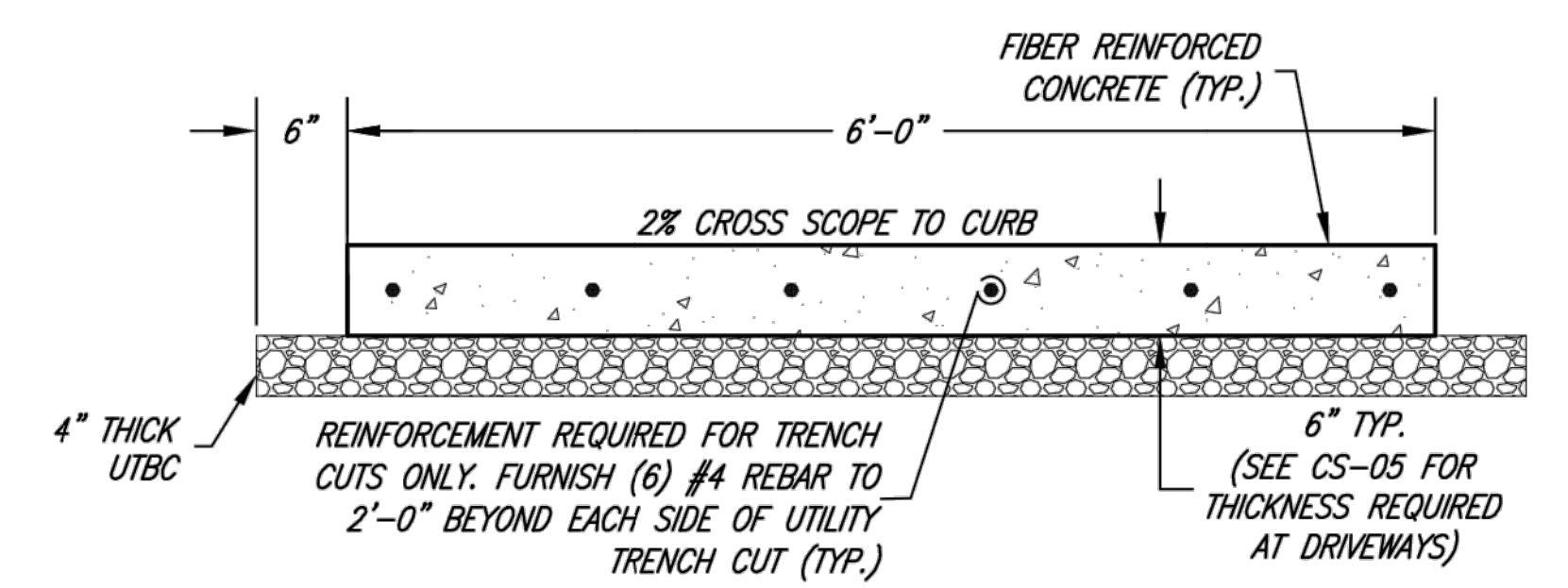

1 SIDEWALK SECTION (CITY STANDARD) N.T.S.

CURB & GUTTER NOTES:

- A1. WHEN REPLACING CURB DUE TO CONSTRUCTION ACTIVITY, NEW CURB MUST EXTEND 5' MIN. PAST TRENCH ON EACH SIDE.
- B1. CONCRETE CURB TO BE CONSTRUCTED USING SLIPFORMS, HAND FORMED OR STATIONARY FORMS ARE ONLY ALLOWED FOR CURB TIE-INS.
- C1. THE SLOPE FOR CURB & GUTTER MUST BE A MINIMUM OF 0.5%.

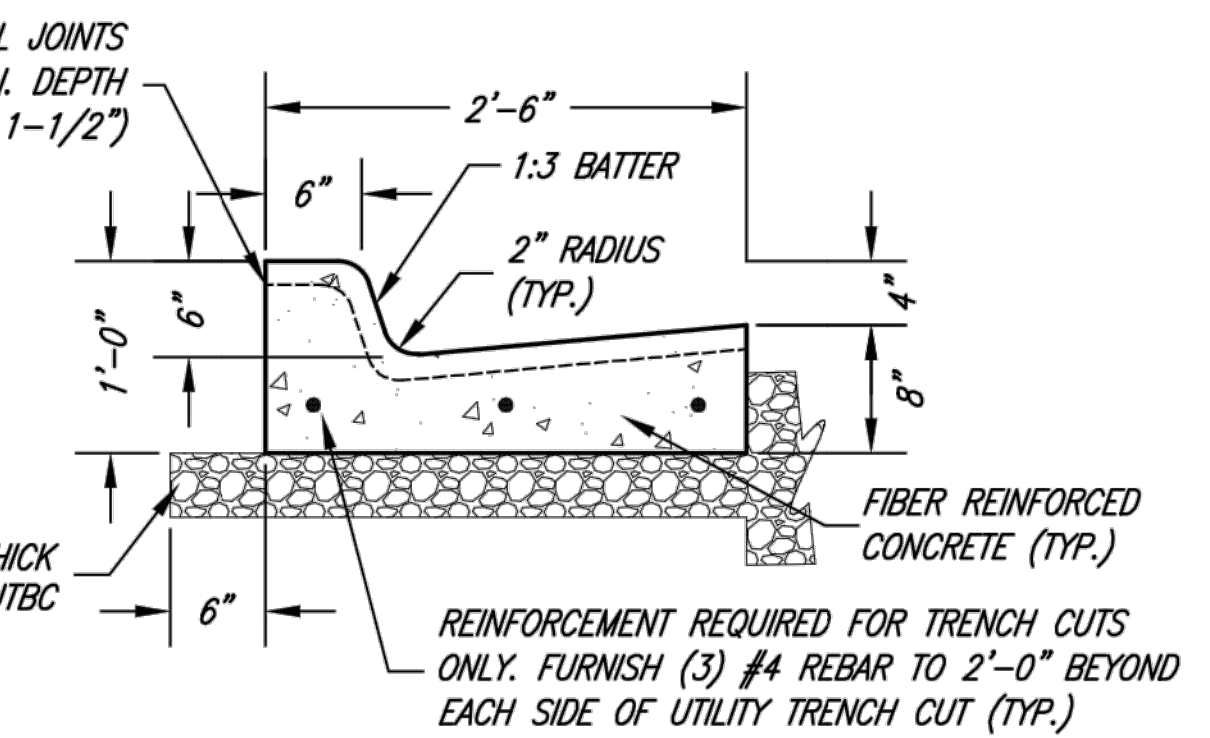

3 CURB & GUTTER SECTION (CITY STANDARD)

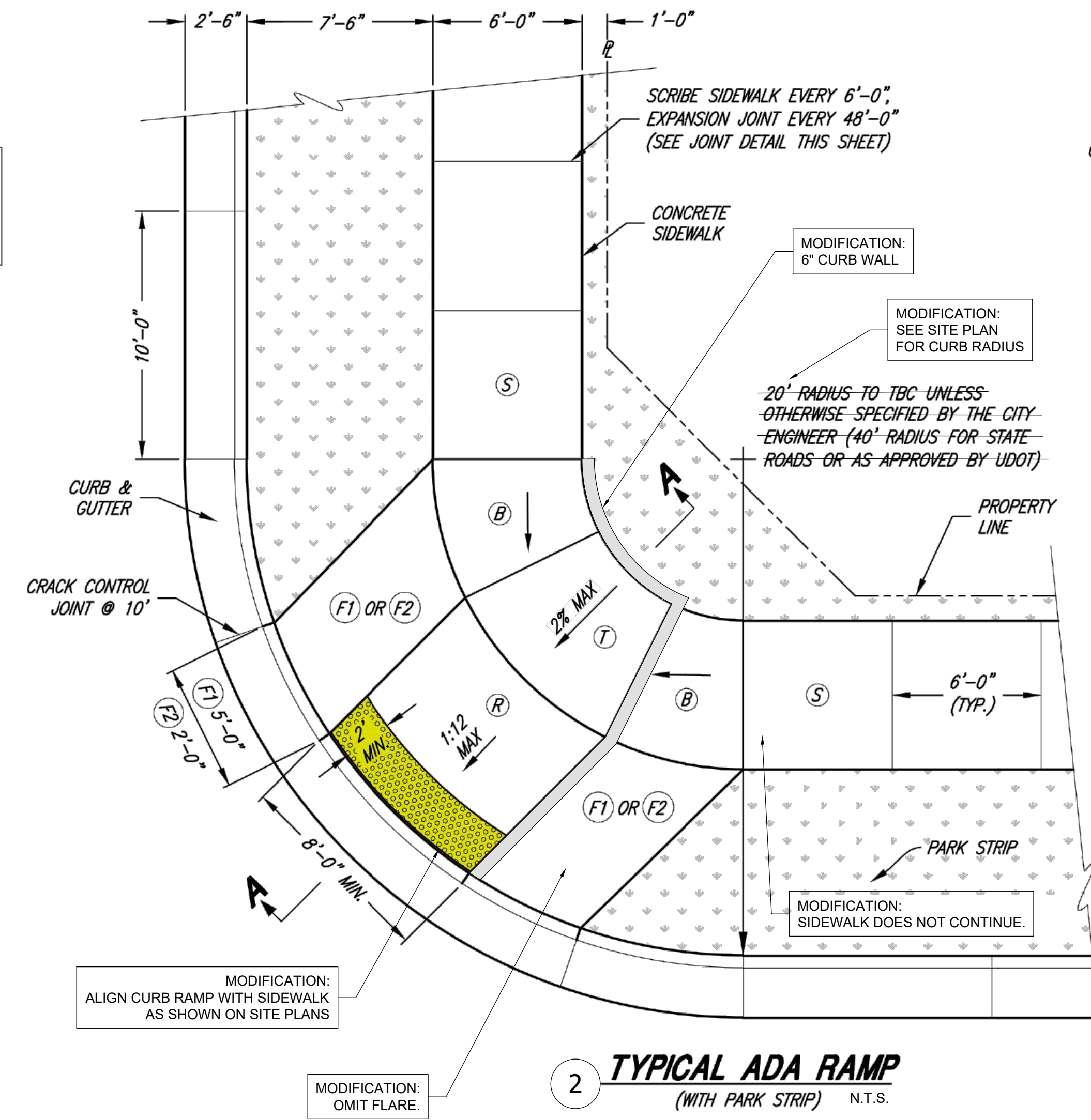

2 TYPICAL ADA RAMP (WITH PARK STRIP) N.T.S.

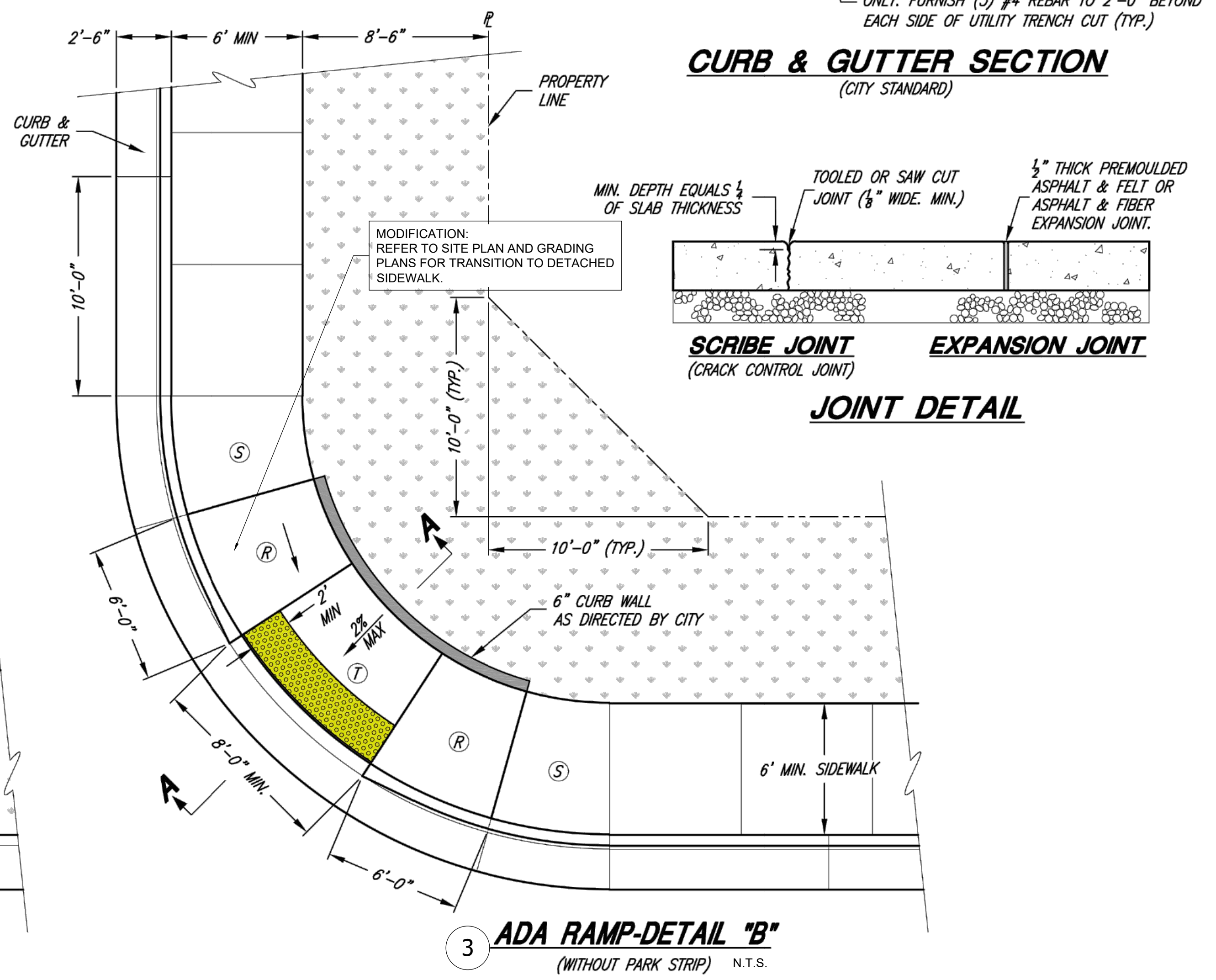

3 ADA RAMP-DETAIL 'B' (WITHOUT PARK STRIP) N.T.S.

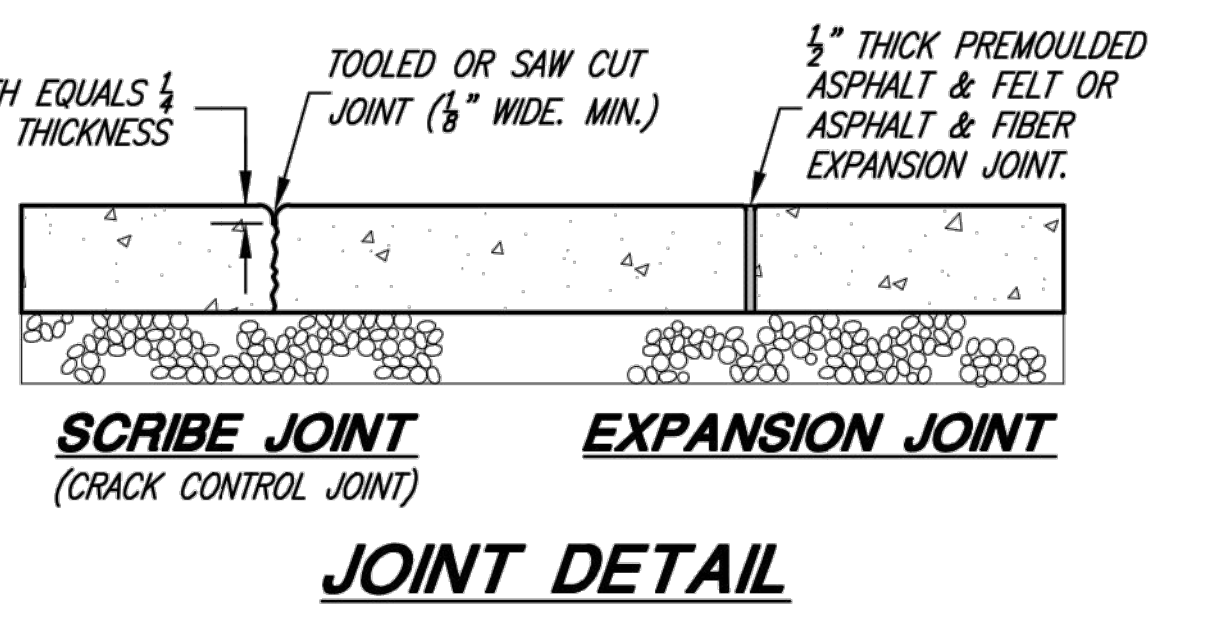

JOINT DETAIL

REGISTERED PROFESSIONAL ENGINEER
BRANDON KENT JONES
No. 5148758
State of Utah
PROJECT ENGINEER
2-12-2019
DATE

REV.	DATE	APPR.	ADDED NOTES
1	JAN '19	BKJ	

SCALE: N.T.S.
DESIGNED: BKJ
DRAWN: BEB
CHECKED: BKJ

JONES & ASSOCIATES
CONSULTING ENGINEERS
6080 Fashion Point Drive
South Ogden, Utah 84403 (801) 476-9767
www.jonescivil.com

SOUTH WEBER CITY CORPORATION
PUBLIC WORKS STANDARDS
PUBLIC ROADS - TYPICAL ADA RAMP, SIDEWALK, CURB & GUTTER, AND CONCRETE JOINT DETAILS
SHEET: CS-06 OF 24 SHEETS

REVISIONS: DATE DESCRIPTION

SCALE: 1"=50'

DATE: 1/4/2023

DESIGN: WJS

DRAWN: WJS

CHECKED: TMM

DWG.: 18V102 - SOUTH WEBER LOCAL - GENERAL BY SOUTH WEBER DESIGN/CITY ENGINEER

CIVIL UTILITY DETAILS

RV GENERAL

546 EAST OLD FORT ROAD

SOUTH WEBER CITY, DAVIS COUNTY, UTAH

GARDNER ENGINEERING
CIVIL-LAND PLANNING
MUNICIPAL-LAND SURVEYING
5150 SOUTH 375 EAST OGDEN, UT
OFFICE: 801.476.0202 FAX: 801.476.0066

CE5-10

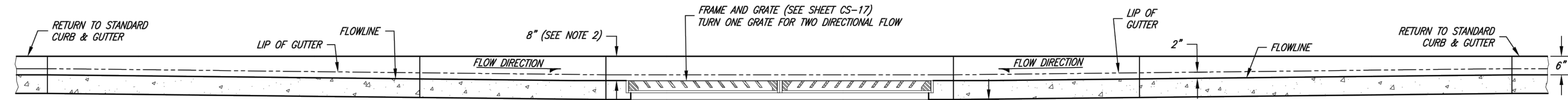
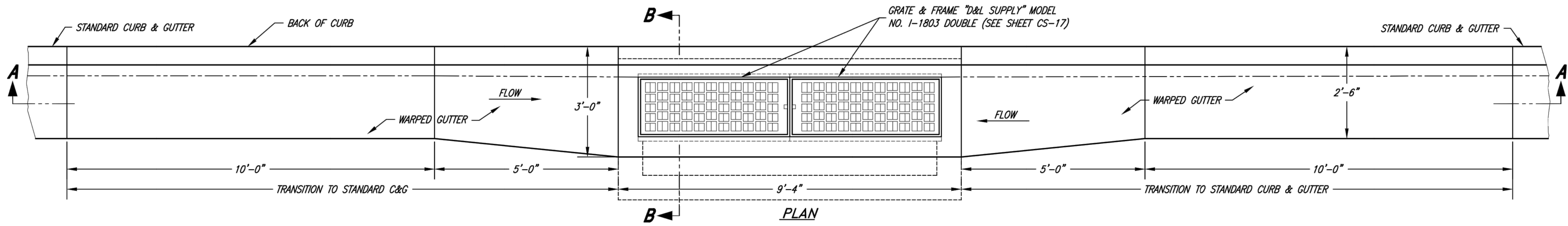

STANDARD CATCH BASIN DIMENSION TABLE					
PIPE SIZE (IN.)	"X"	SINGLE CATCH BASIN		DOUBLE	"Z" MIN.
		"Y" (ANGLE A)	"Y" (ANGLE B)		
15	2'-6"	4'-0"	4'-0"	8'-0"	2'-0"
18	2'-6"	4'-0"	4'-0"	8'-0"	2'-6"
21	4'-0"	4'-0"	4'-0"	8'-0"	3'-0"
24	4'-0"	4'-0"	5'-0"	8'-0"	3'-0"
30	4'-0"	4'-0"	6'-0"	8'-0"	3'-6"
36	4'-0"	5'-0"	6'-0"	8'-0"	4'-0"
42	6'-0"	6'-0"	7'-0"	8'-0"	5'-0"
48	6'-0"	6'-0"	8'-0"	8'-0"	5'-6"

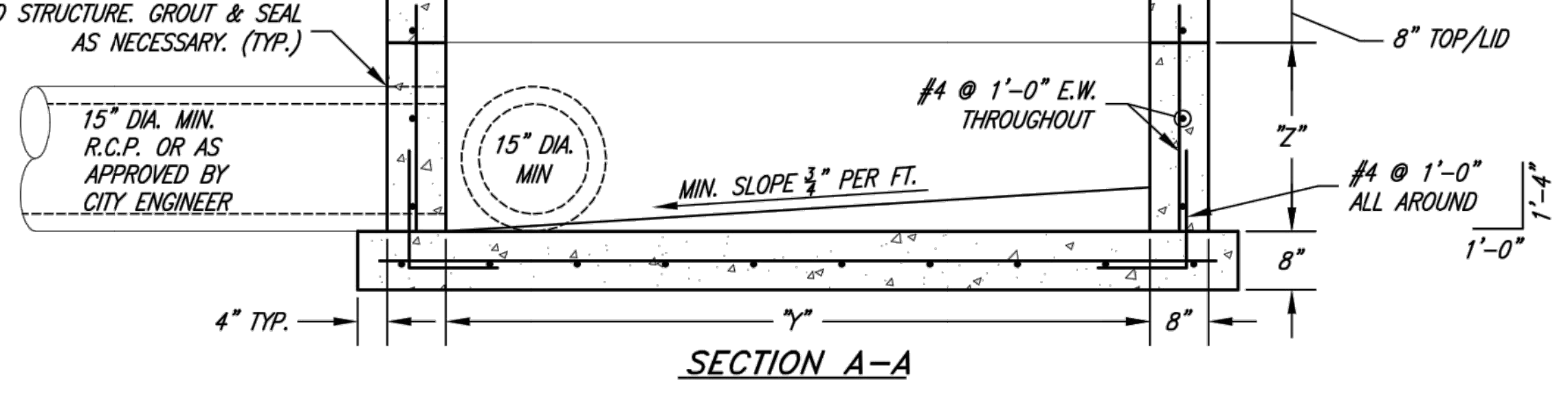

1 DOUBLE CATCH BASIN N.T.S.

- GENERAL NOTES:
- ALL CATCH BASIN BOX SIZES REFLECT DIMENSIONS FOR THE MINIMUM 15" PIPE SIZE. BOX DIMENSIONS MUST INCREASE PROPORTIONALLY TO ACCOMMODATE LARGER PIPE SIZES.
 - DEPTH MAY VARY FROM 6" TO 10" AS DIRECTED BY THE CITY ENGINEER
 - CAST-IN-PLACE CONCRETE CATCH BASINS CAN BE REPLACED WITH PRECAST CONCRETE CATCH BASINS WITH HL-93 DECK LOADING AND COMPARABLE SIZE.
 - ALL BOXES SHALL BE FORMED ON THE INSIDE AND OUTSIDE OF THE BOX AND INSPECTED BY THE CITY PRIOR TO THE PLACING OF CONCRETE.
 - DOUBLE CATCH BASINS WILL BE REQUIRED IN LOCATIONS SPECIFIED BY THE CITY ENGINEER (TYPICALLY IN LOW SPOTS OR WHERE ADDITIONAL INLET CAPACITY IS NEEDED).
 - STORM DRAIN LINES SHALL BE 15 INCH MINIMUM DIAMETER REINFORCED CONCRETE PIPE (RCP), OF APPROPRIATE CLASS.
 - ALTERNATE STRUCTURE (E.G. COMBO BOXES) MAY BE USED WITH APPROVAL OF THE CITY ENGINEER. STRUCTURES SHALL FOLLOW APWA STANDARD PLANS AND BE A COMMON SIZE.

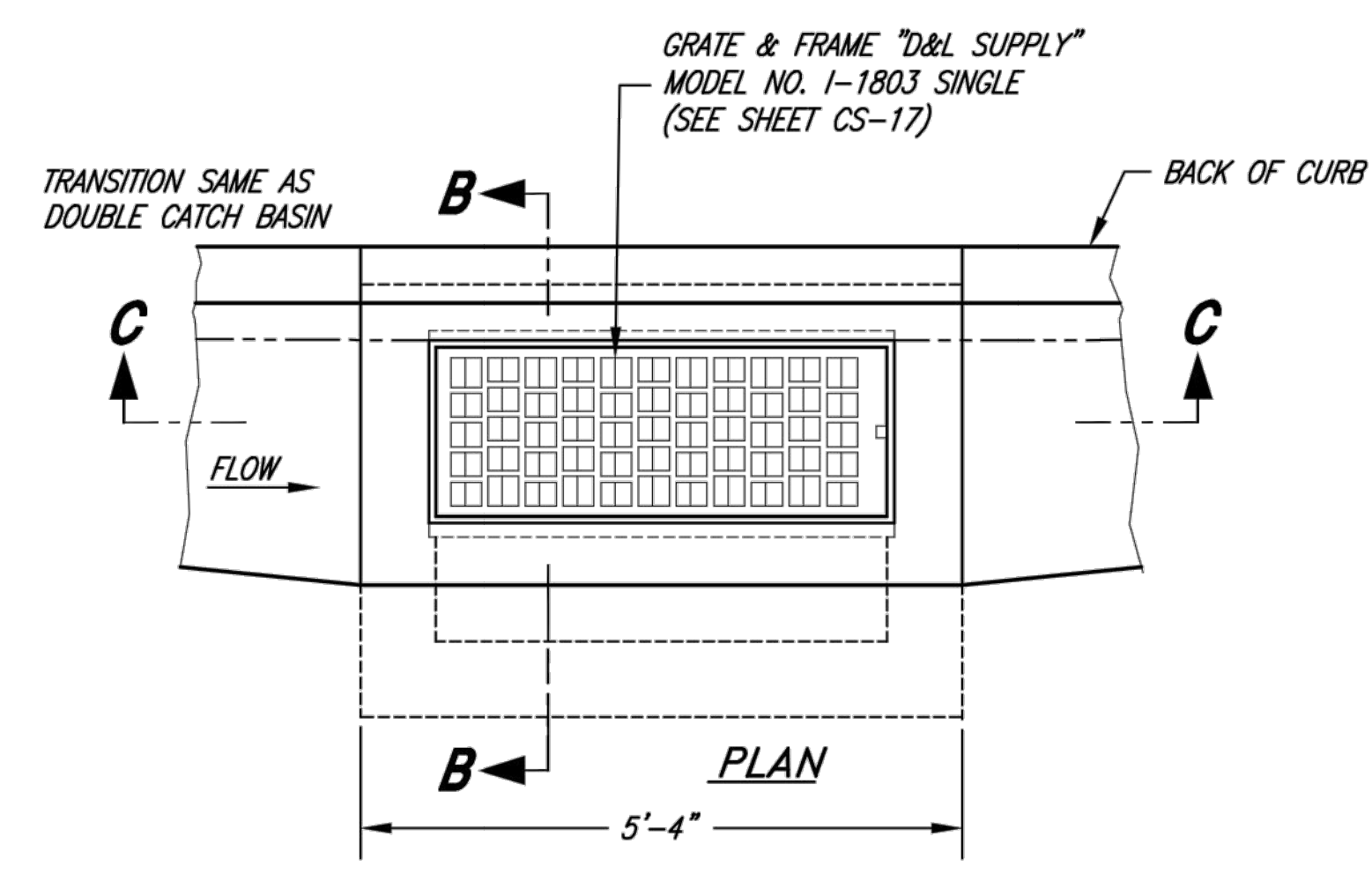
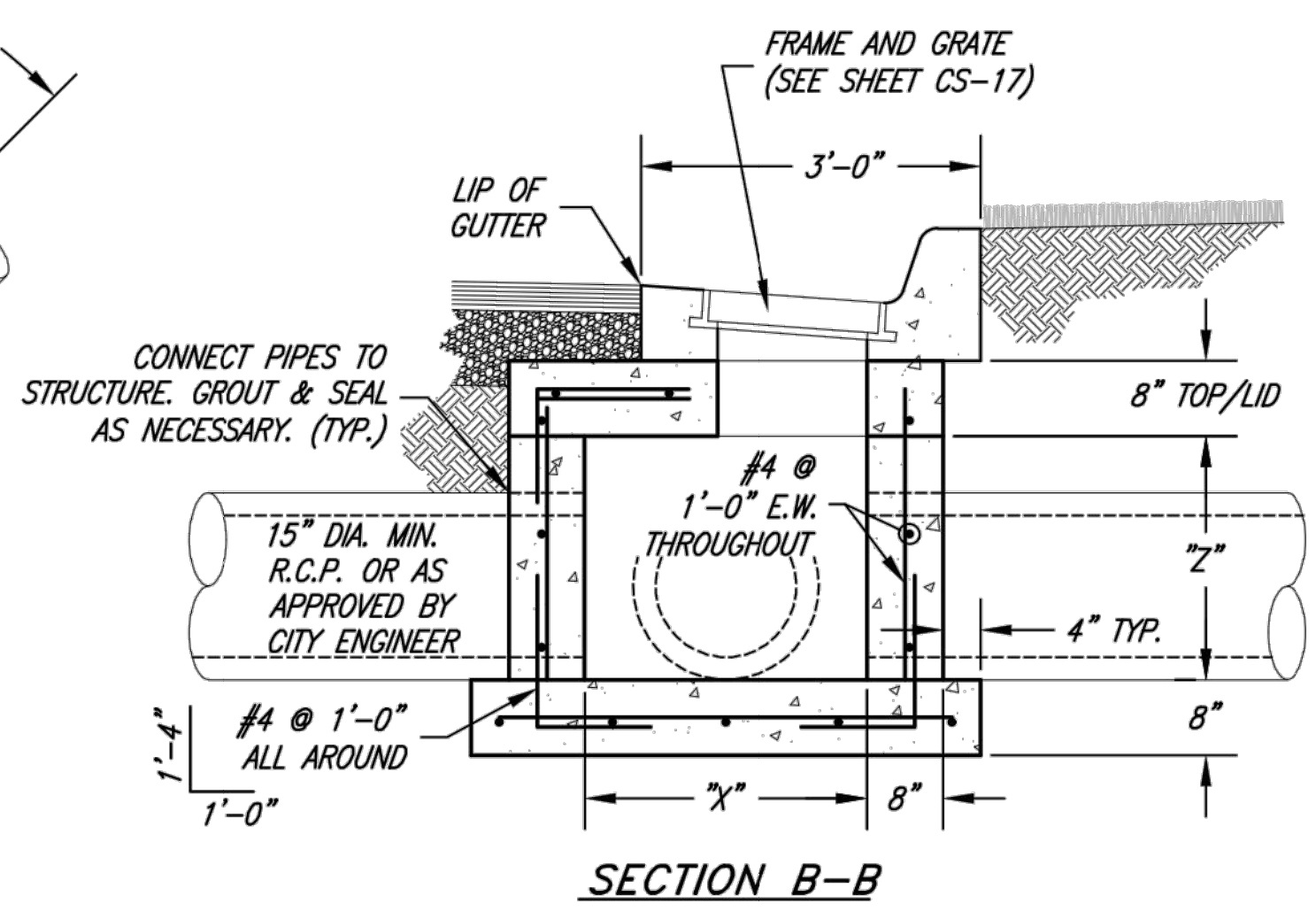
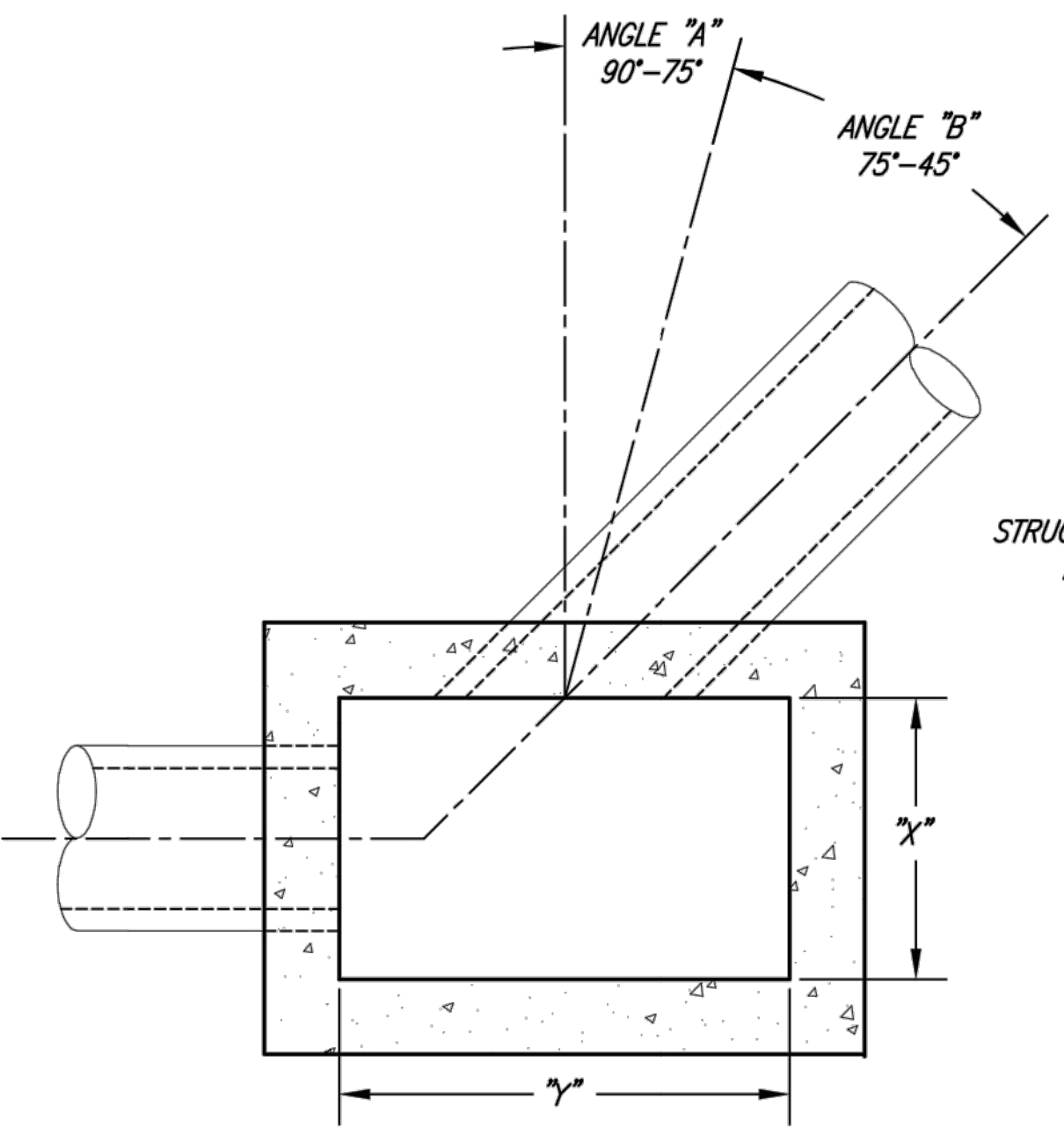

2 SINGLE CATCH BASIN N.T.S.

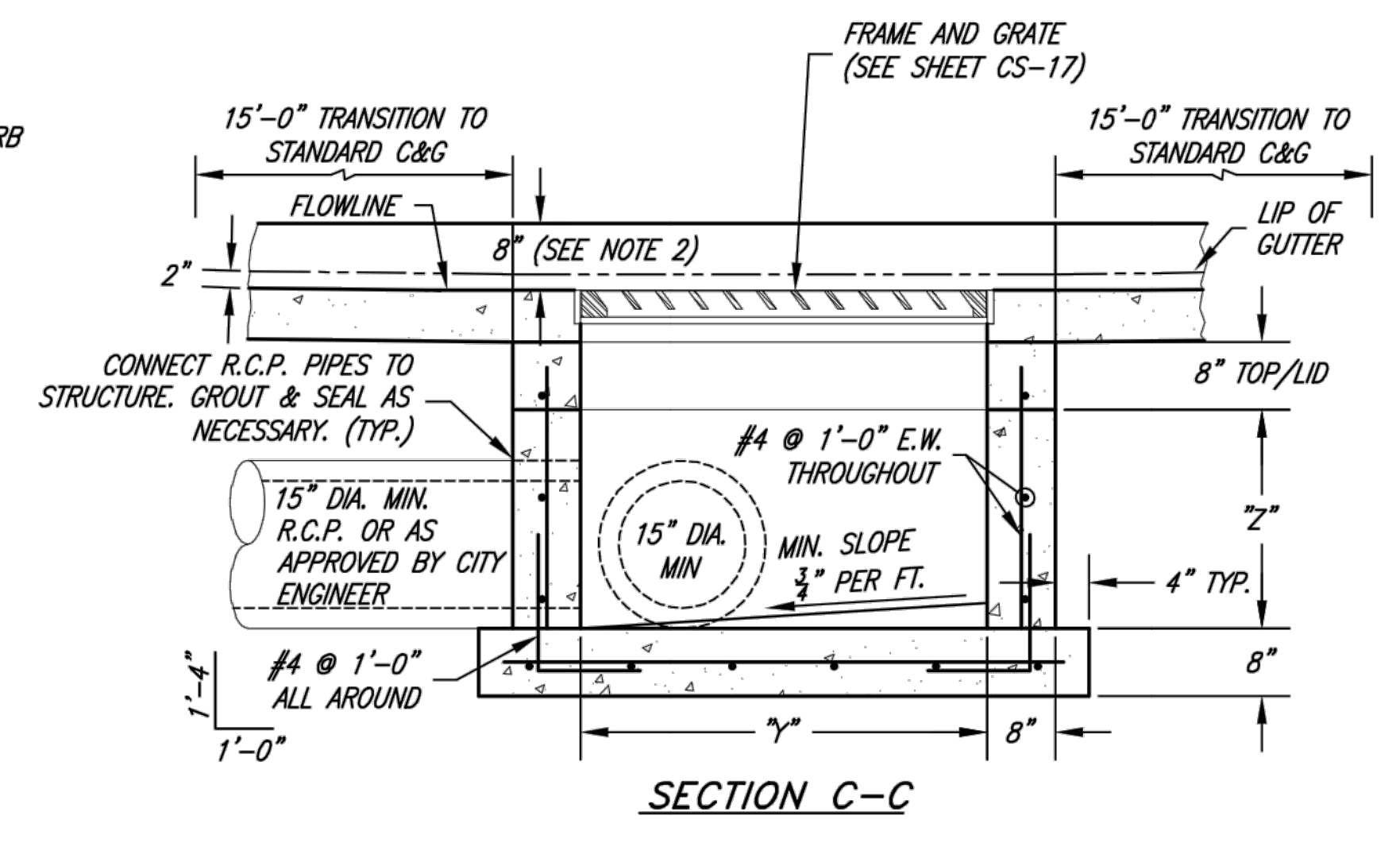

REGISTERED PROFESSIONAL ENGINEER
 BRANDON KENT JONES
 No. 5148758
 PROJECT ENGINEER
 2-12-2019
 DATE

REV.	DATE	APPR.	ADDED NOTE
1	JAN '19	BKJ	ADDED NOTE

SCALE:
 N. T.S.
 DESIGNED: BKJ
 DRAWN: BEB
 CHECKED: BKJ

JONES & ASSOCIATES
 CONSULTING ENGINEERS
 6080 Fashion Point Drive
 South Ogden, Utah 84403 (801) 476-9767
 www.jonescivil.com

SOUTH WEBER CITY CORPORATION
 PUBLIC WORKS STANDARDS
 SHEET: CS-16
 OF 24 SHEETS
 0

SCALE: 1"=5'
 DATE: 1/4/2023
 DESIGN: WJS
 DRAWN: WJS
 CHECKED: TMN
 DWG: 181102 - SOUTH WEBER CITY - GENERAL BY SOUTH WEBER CITY ENGINEERS

REVISIONS
 DATE DESCRIPTION

CIVIL UTILITY DETAILS
 RV GENERAL
 546 EAST OLD FORT ROAD
 SOUTH WEBER CITY, DAVIS COUNTY, UTAH

GARDNER ENGINEERING
 CIVIL - LAND PLANNING
 MUNICIPAL - LAND SURVEYING
 5150 SOUTH 375 EAST OGDEN, UT
 OFFICE: 801.476.0202 FAX: 801.476.0066

CE5-11

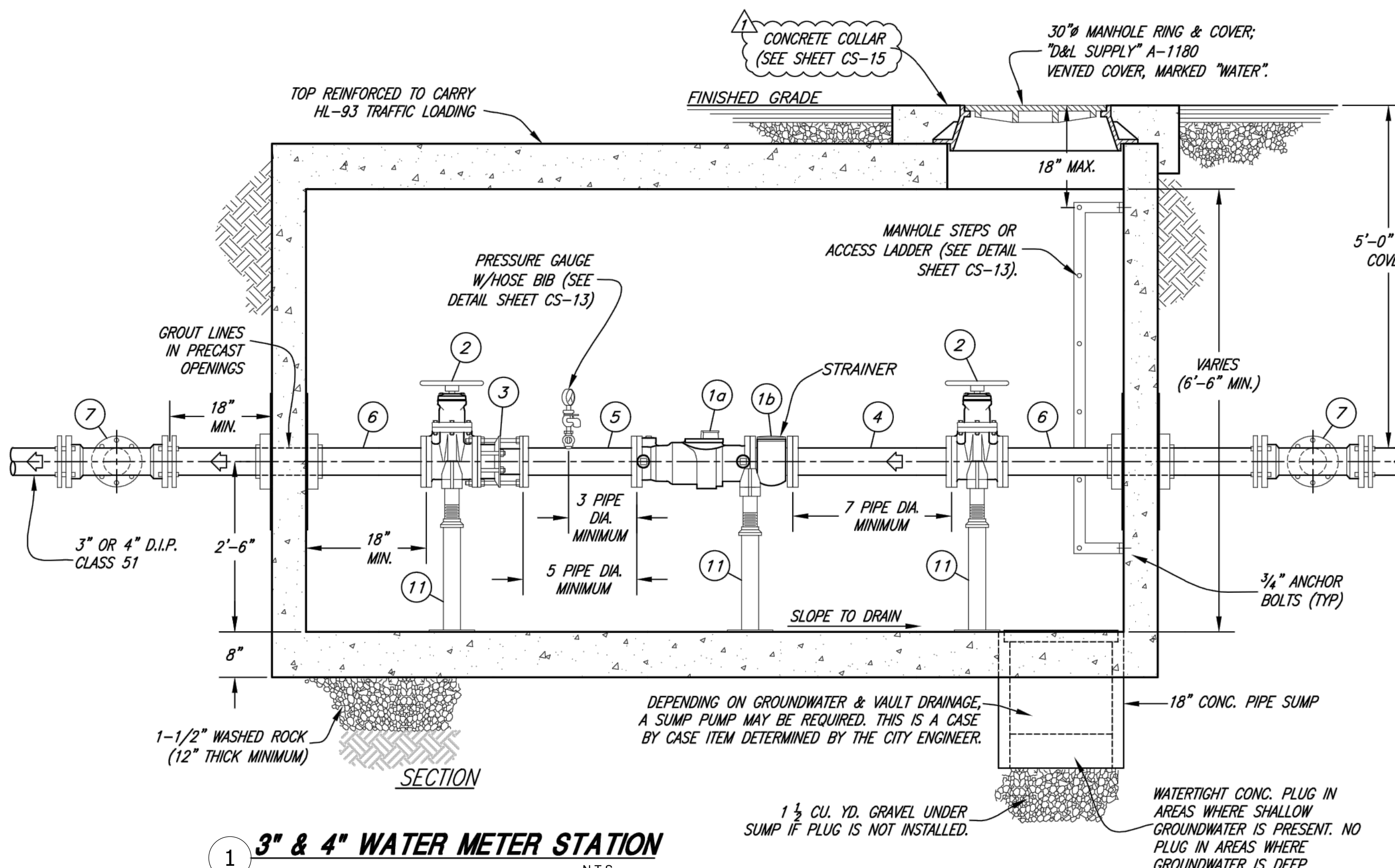
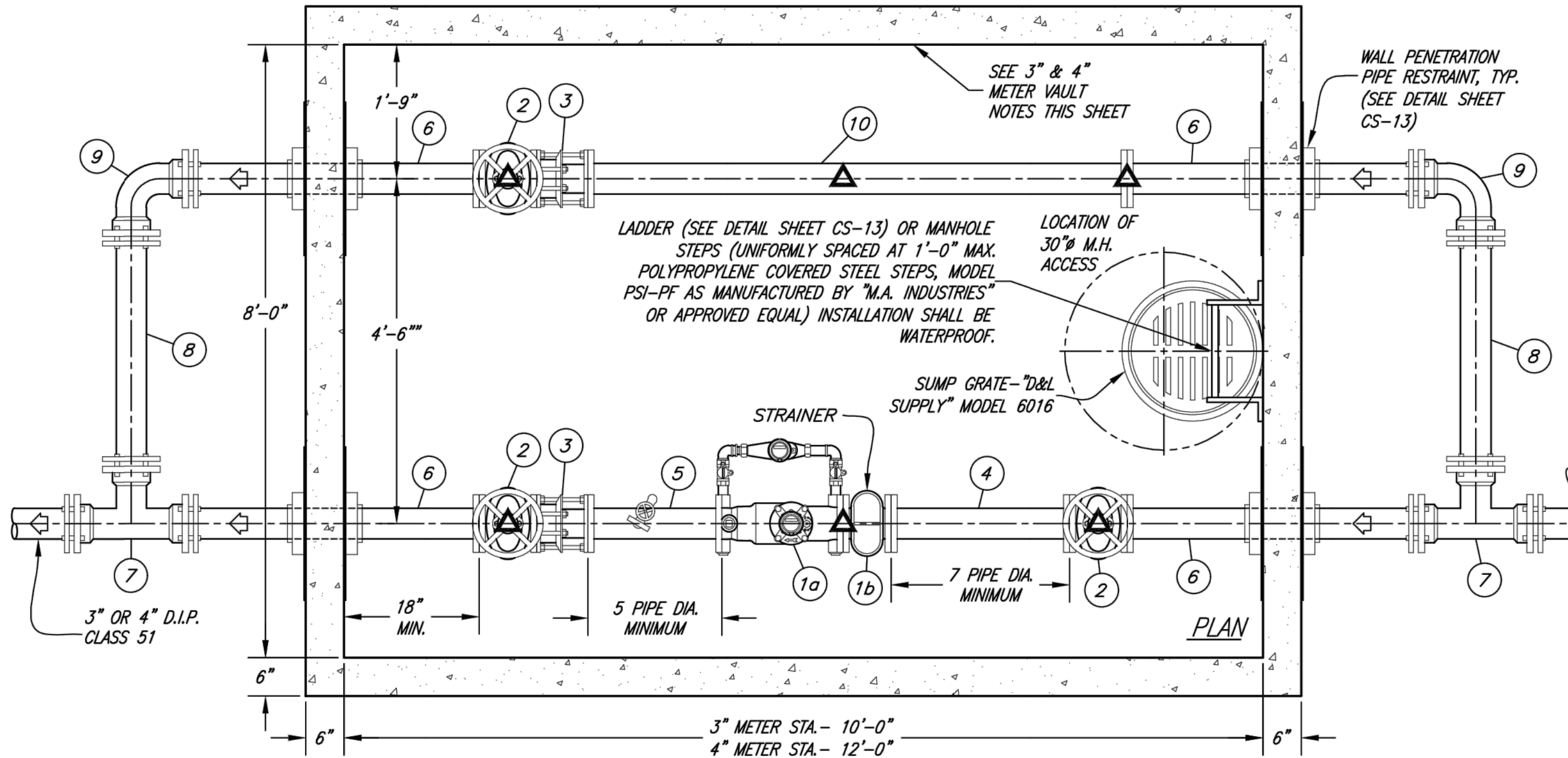

1 3\"/>

- 3\"/>**
- A1. ALL FITTINGS OUTSIDE OF THE VAULT ARE TO BE DUCTILE IRON MJ WITH THRUST RESTRAINT RETAINER GLANDS ("ROMAC", MJRG, OR APPROVED EQUAL)
 - A2. PENETRATION WALLS NEED TO BE ADEQUATELY DESIGNED STRUCTURALLY FOR ANTICIPATED THRUST.
 - A3. THE PRECAST VAULT MANUFACTURER IS RESPONSIBLE FOR DESIGN RELATED TO TRAFFIC LOADING AND THRUST. VERIFICATION OF PROPER DESIGN MUST BE PROVIDED TO THE CITY BY THE DEVELOPER, CONTRACTOR, OR PROPERTY OWNER AS THE CASE MAY BE.
 - A4. ALL FITTINGS SHALL BE AWWA C-110 WITH 125 LB. FLANGES. ALL PIPING SHALL BE DUCTILE IRON PIPE CLASS 350 P.S.I. MIN.

NOTE:
 ALL SPECIFIED BRANDS OF MATERIALS SHOWN ON THESE DRAWINGS ARE "CITY STANDARDS." OTHER EQUIVALENT BRANDS MAY BE USED WITH THE PRIOR APPROVAL OF THE CITY ENGINEER AND THE CITY WATER SYSTEM SUPERINTENDENT.

- GENERAL NOTES:**
- C1. PROPERTY OWNER OR CONTRACTOR SHALL PAY FOR ALL COSTS OF INSTALLATION INCLUDING ALL MATERIALS, ALL EXCAVATION AND FILL, ASPHALT REPLACEMENT AND WATER MAIN CONNECTION.
 - C2. INSPECTION OF ALL WATER LINE INSTALLATIONS WILL BE DONE BY THE CITY WATER DEPARTMENT, WITH A 48 HOUR MINIMUM NOTICE REQUIRED PRIOR TO START OF WORK.
 - C3. IF APPLICABLE, A CITY EXCAVATION PERMIT MUST BE REQUESTED AND APPROVED PRIOR TO START OF WORK.
 - C4. "BLUE" BOLTS AND NUTS ARE REQUIRED BY THE CITY.
 - C5. CONTRACTOR TO SUPPLY ALL METERS 1 1/2" OR LARGER.

- 1 1/2\"/>**
- B1. 1/2" SERVICE LINE-13" METER
2" SERVICE LINE-17" METER
 - B2. NO MORE THAN 12" OF GRADE RINGS TO BE ALLOWED ON ANY MANHOLE
 - B3. MANHOLE STEPS (FOR MANHOLES OVER 6' DEEP.) UNIFORMLY SPACED (1'-0" MAX.) POLYPROPYLENE COVERED STEEL STEPS, MODEL PSI-PF AS MANUFACTURED BY "M.A. INDUSTRIES" OR APPROVED EQUAL - INSTALLATION OF STEPS SHALL BE WATERPROOF.

PIPE & FITTING SCHEDULE

NO.	DESCRIPTION (3" & 4" METER STA.)	JOINT TYPE	LINE	
			3"	4"
1a	"MASTER METER" DUAL BODY COMPOUND (DBC) METER	FL	3"	4"
1b	W/ STRAINER & 3G INTEGRATED REGISTER			
2	"MUELLER" RESILIENT WEDGE GATE VALVE W/ HANDWHEEL	FL	3" A-2362	4" A-2361
3	"ROMAC" DJ400 DISMANTLING JOINT	FL	3"	4"
4	SPOOL PIECE (7 PIPE DIA. MINIMUM)	FL	3"	4"
5	SPOOL PIECE (5 PIPE DIA. MINIMUM)	FL	3"	4"
6	NIPPLE	FLxPE	3"	4"
7	TEE	MJ	3"	4"
8	PIPE SECTION	PE	3"	4"
9	90° ELBOW	MJ	3"	4"
10	SPOOL PIECE	FL	3"	4"
11	"CLOW" F-1608 OR "ANVIL" #264 GALV. PIPE SUPPORT W/ COMPANION FLANGE & VARIABLE HEIGHT NIPPLE (6 EA REQ'D)			

NO.	DESCRIPTION (1 1/2" & 2" METER STA.)	JOINT TYPE	LINE	
			1 1/2"	2"
12	"MASTER METER" INTERMEDIATE MULTI-JET METER W/3G INTEGRATED REGISTER	FL	1 1/2"	2"
13	"MUELLER" B-2423-2 METER YOKE (18" RISER)	-	1 1/2"	2"
14	"MUELLER" 110 COMPRESSION CONN. COUPLING	-	1 1/2"	2"

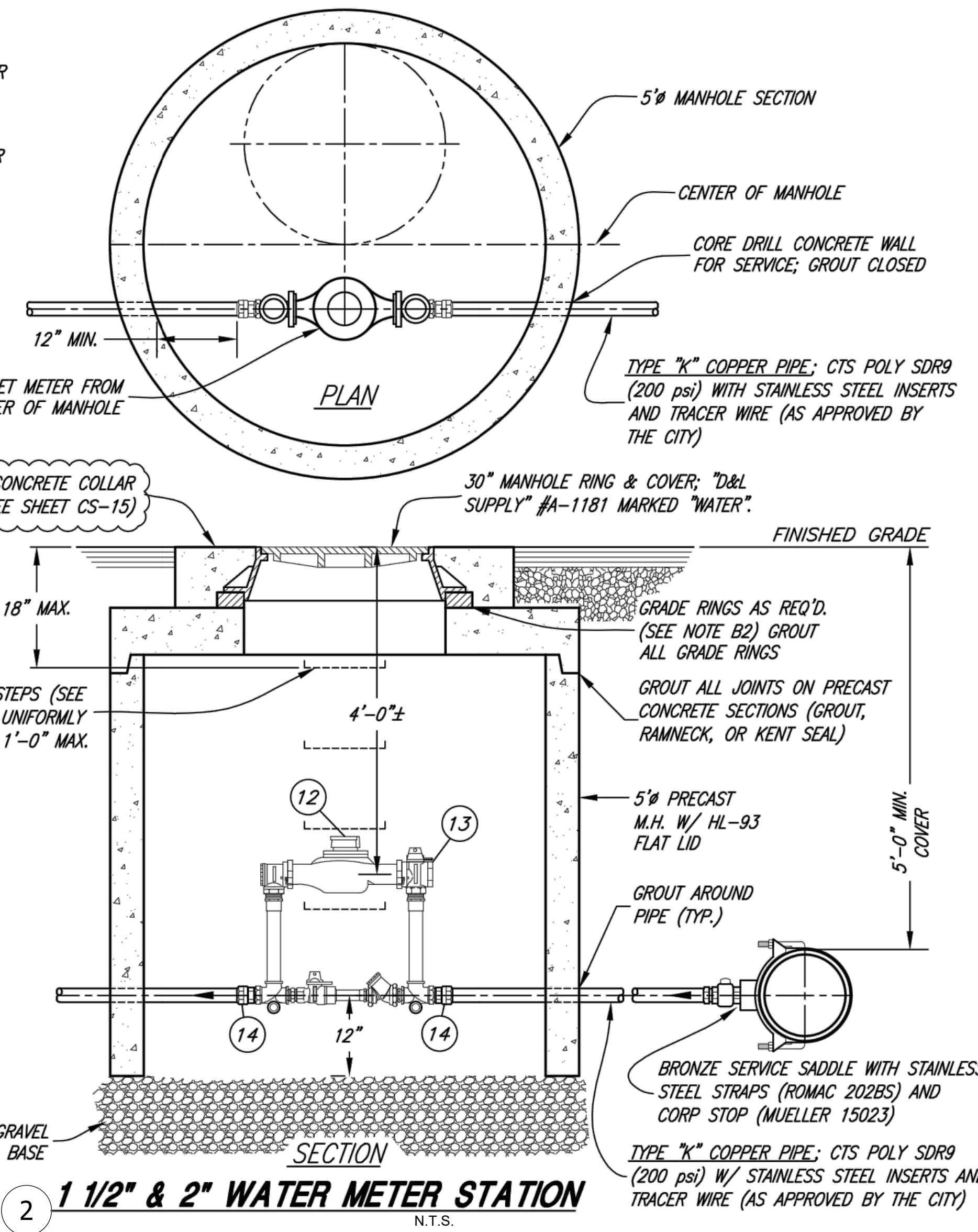

2 1 1/2\"/>

REGISTERED PROFESSIONAL ENGINEER
 BRANDON KENT JONES
 No. 5148758
 State of Utah
 PROJECT ENGINEER
 2-12-2019
 DATE

REV.	DATE	APPR.	MODIFIED NOTES
1	JAN '19	BKJ	MODIFIED NOTES

SCALE:
 N. T.S.
 DESIGNED: BKJ
 DRAWN: BEB
 CHECKED: BKJ



CONSULTING ENGINEERS
 6080 Fashion Point Drive
 South Ogden, Utah 84403 (801) 476-9767
 www.jonescivil.com

SOUTH WEBER CITY CORPORATION
PUBLIC WORKS STANDARDS
CULINARY WATER - STANDARD WATER METER STATIONS
 SHEET: **CS-11**
 OF 24 SHEETS
 0

SCALE: 1"=50'
 DATE: 1/14/2023
 DESIGN: WJS
 DRAWN: WJS
 CHECKED: TMM
 DWG.: 181192 - SOUTH WEBER LOCAL - GENERAL BY SOUTH WEBER DESIGN/CONSTRUCTION DETAILS

REVISIONS
 DATE DESCRIPTION

PROFESSIONAL STRUCTURAL ENGINEER
 No. 4899845
 TYLER M. NIELSON
 LICENSED
 STATE OF UTAH

CIVIL UTILITY DETAILS
 RV GENERAL
 546 EAST OLD FORT ROAD
 SOUTH WEBER CITY, DAVIS COUNTY, UTAH

GARDNER ENGINEERING
 CIVIL, LAND PLANNING
 MUNICIPAL, LAND SURVEYING
 5150 SOUTH 375 EAST OGDEN, UT
 OFFICE: 801.476.0202 FAX: 801.476.0056

CE5-12

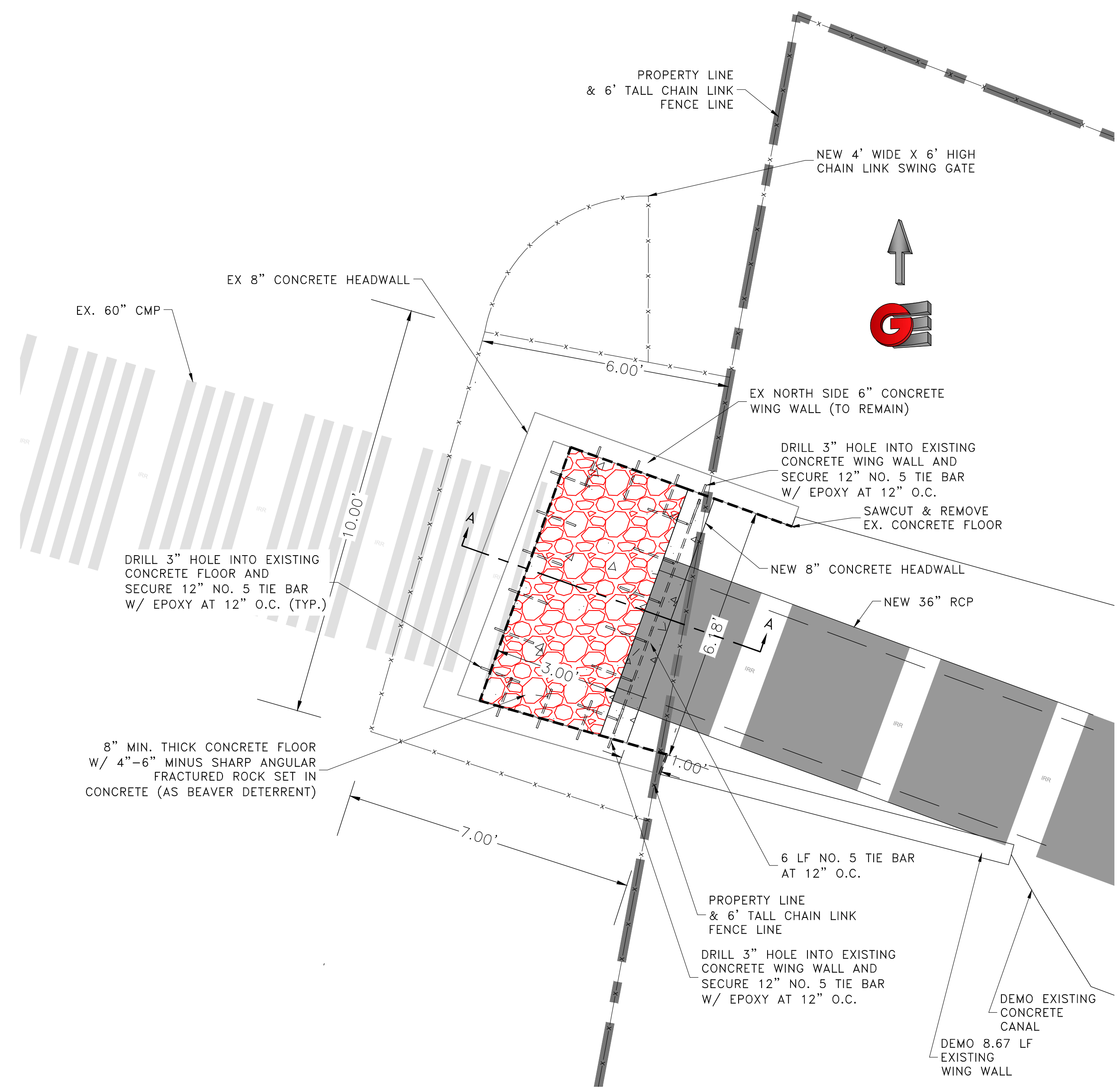

PLAN VIEW

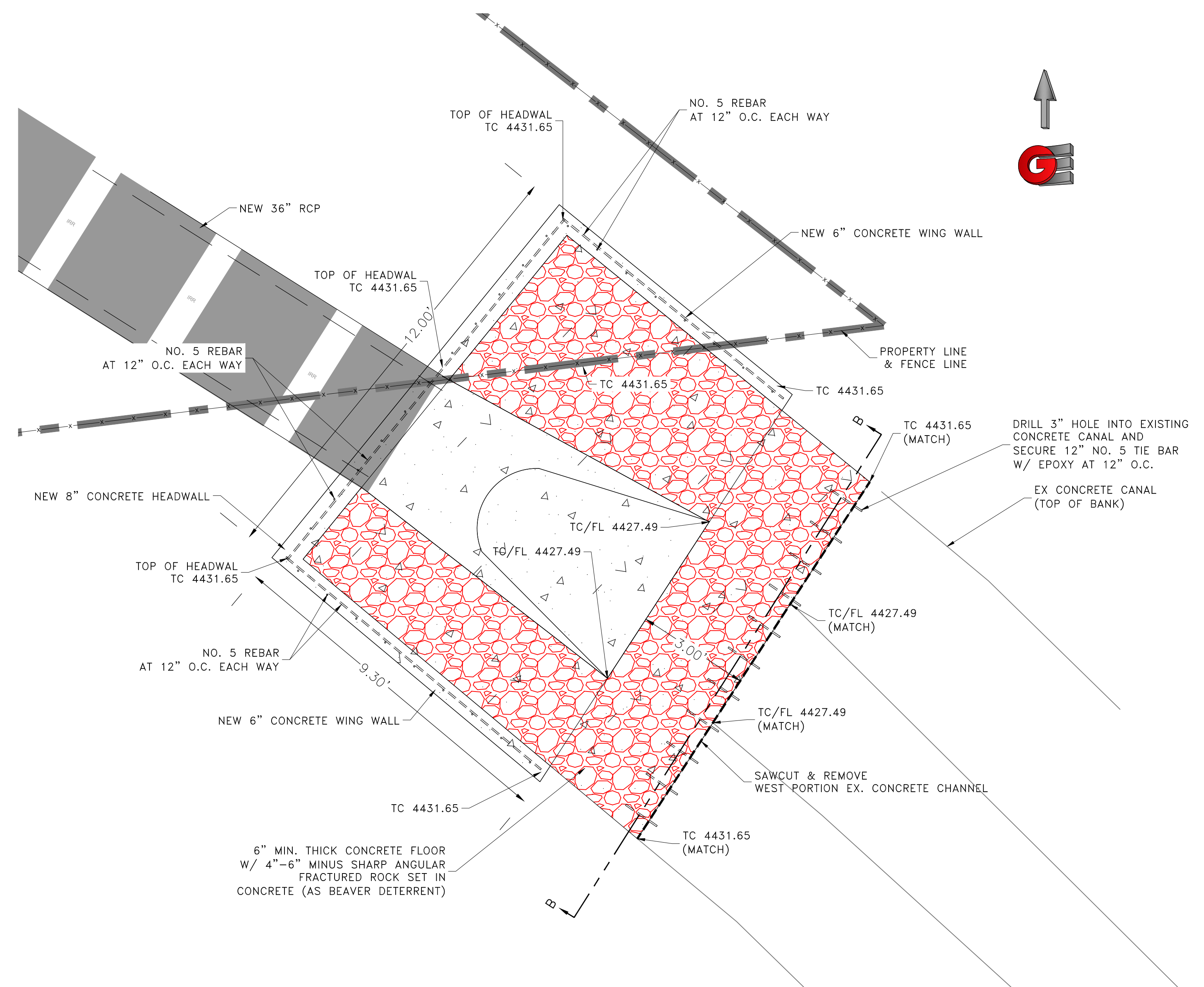

PLAN VIEW

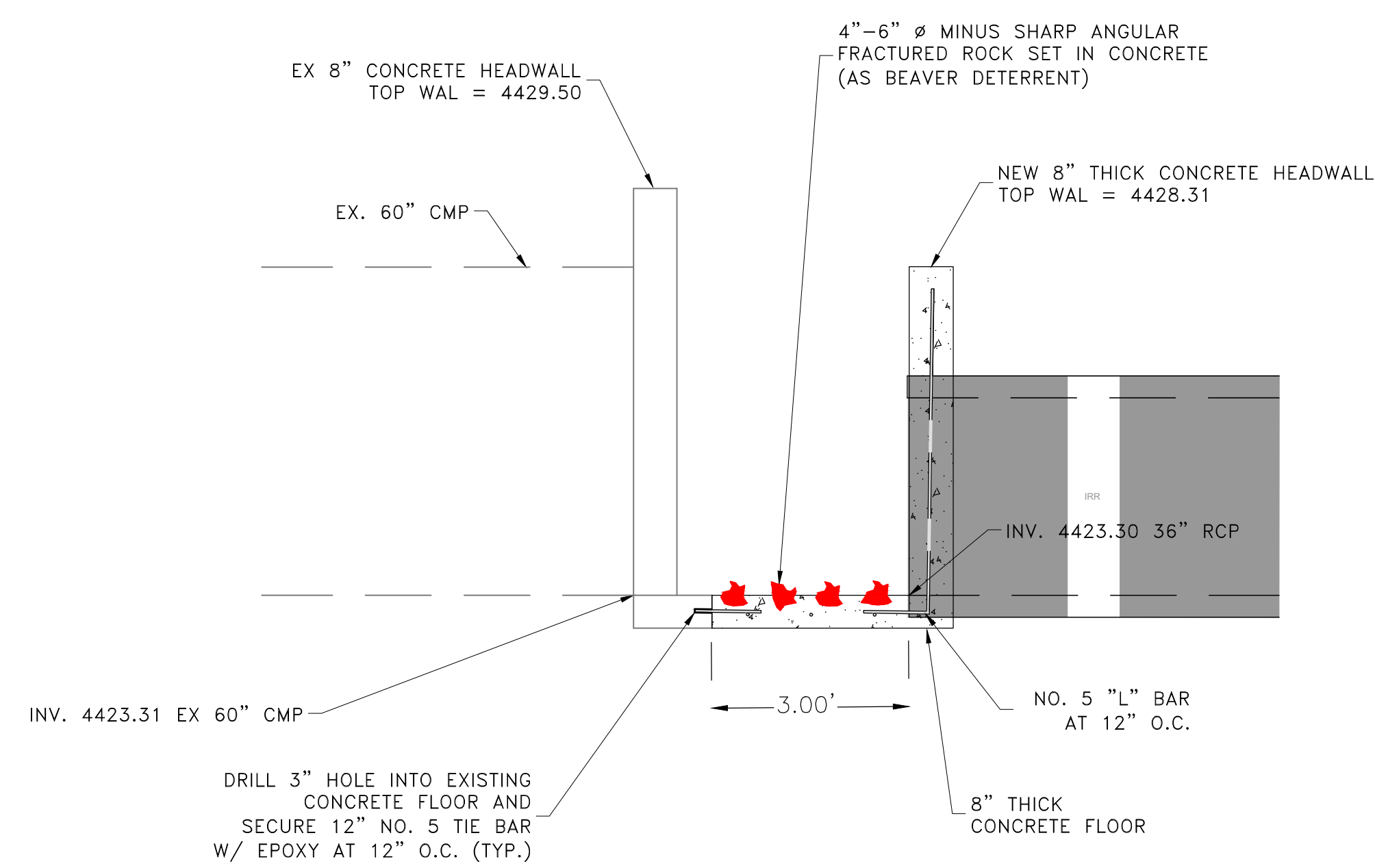

SIDE SECTION VIEW A-A

1 WEST CANAL TIE IN DETAIL
Scale: (NOT TO SCALE)

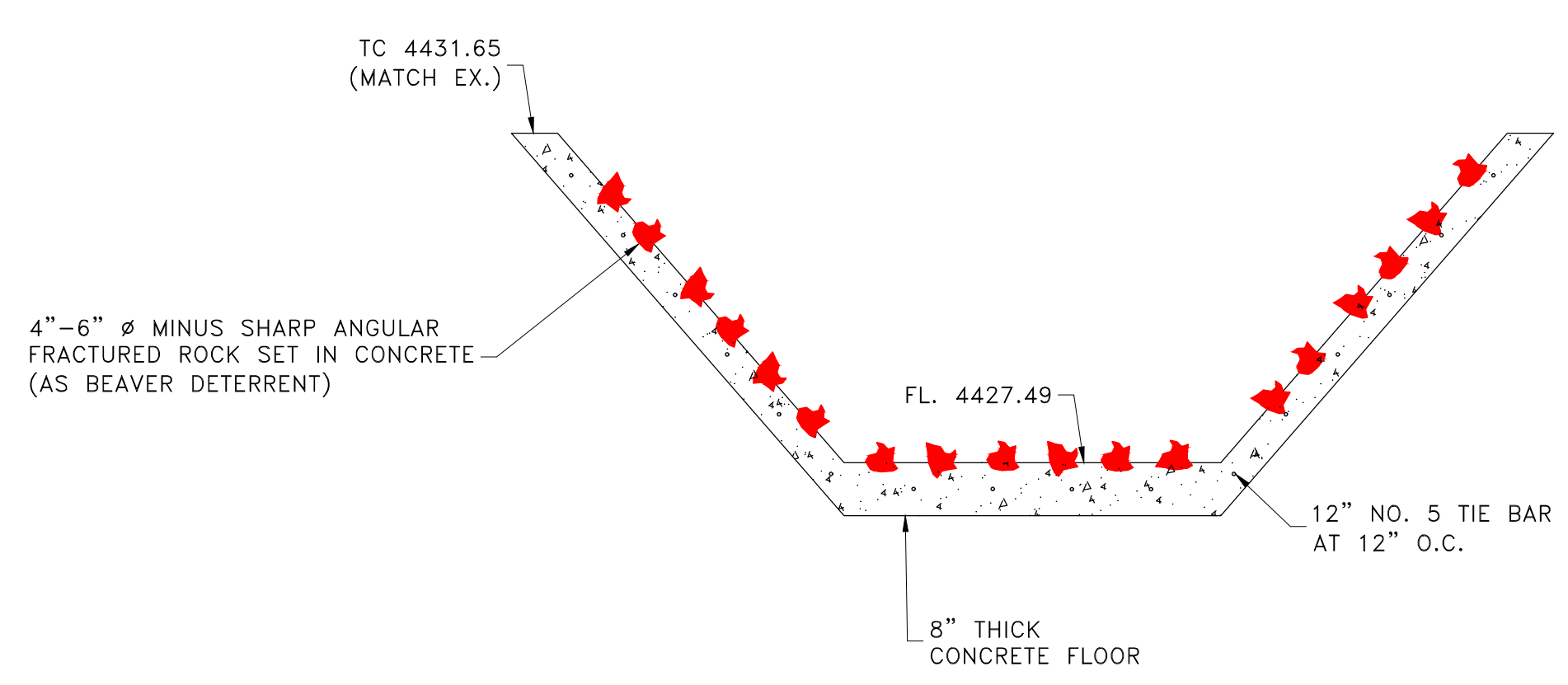

SIDE SECTION VIEW B-B

2 EAST CANAL TIE IN DETAIL
Scale: (NOT TO SCALE)

SCALE: 1"=50'	DATE: 1/4/2023	DESIGN: WJS	DRAWN: WJS	CHECKED: TMN
REVISIONS	DESCRIPTION			
DATE				

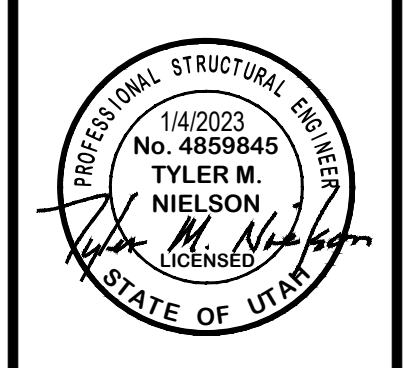

CIVIL UTILITY DETAILS
RV GENERAL
546 EAST OLD FORT ROAD
SOUTH WEBER CITY, DAVIS COUNTY, UTAH

GARDNER ENGINEERING
CIVIL-LAND PLANNING
MUNICIPAL-LAND SURVEYING
5150 SOUTH 375 EAST OGDEN, UT
OFFICE: 801.476.0202 FAX: 801.476.0066

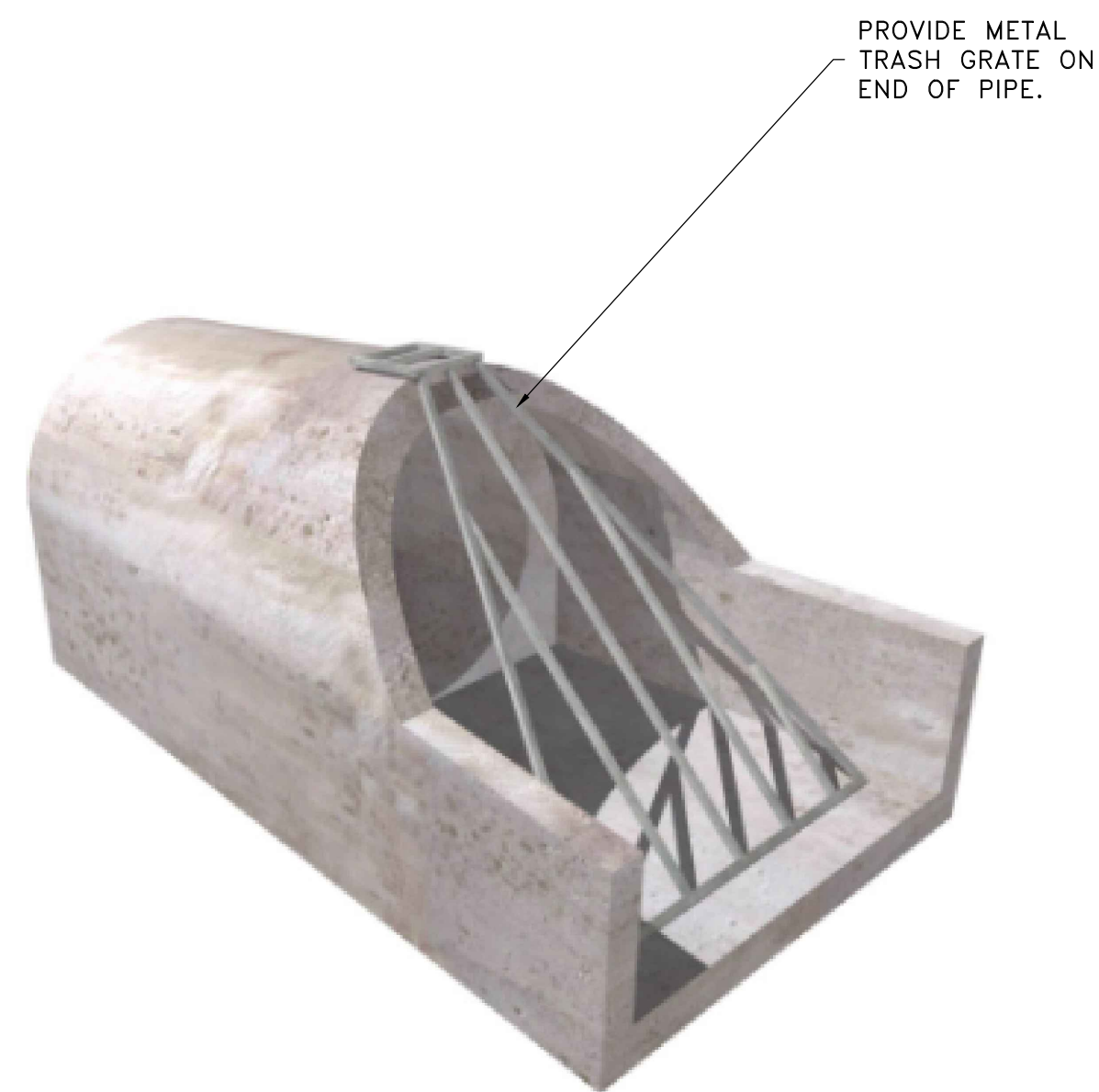
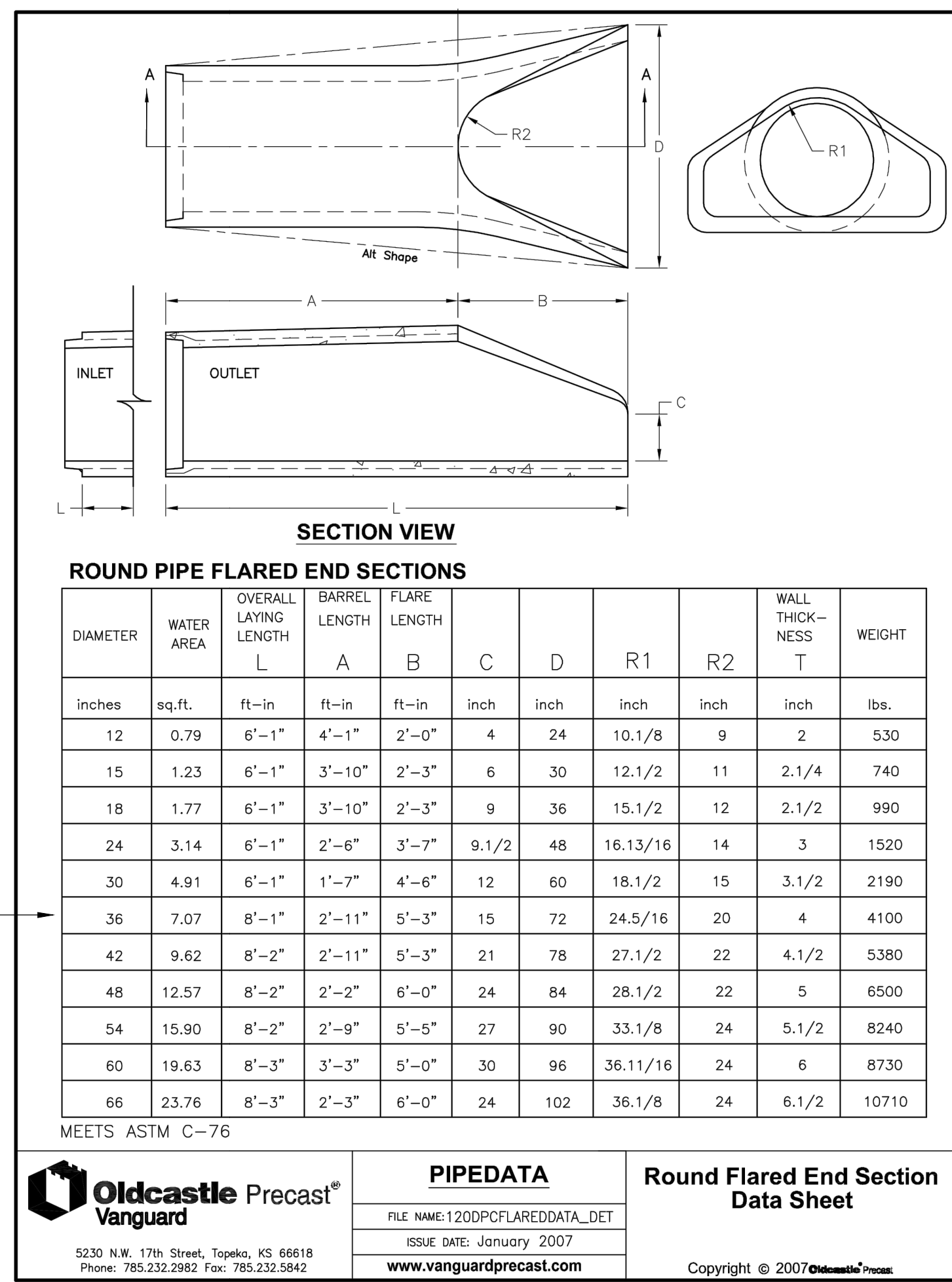

1 36" CONCRETE END SECTION W/ GRATE
Scale: (NOT TO SCALE)

REVISIONS	DESCRIPTION
DATE	

SCALE: 1"=30'
DATE: 1/4/2023
DESIGN: WJS
DRAWN: WJS
CHECKED: TMN
DWG: RLV/RYB - SOUTH WEBER, LIC. 2021 - GENERAL BY SOUTH WEBER/ISSA/CPWC CIVIL/STALLING

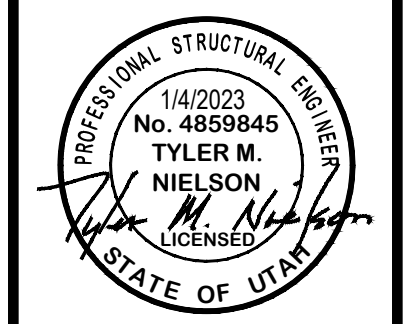

CIVIL UTILITY DETAILS
RV GENERAL
546 EAST OLD FORT ROAD
SOUTH WEBER CITY, DAVIS COUNTY, UTAH

GARDNER ENGINEERING
CIVIL - LAND PLANNING
MUNICIPAL - LAND SURVEYING
5150 SOUTH 375 EAST OGDEN, UT
OFFICE: 801.476.0202 FAX: 801.476.0066

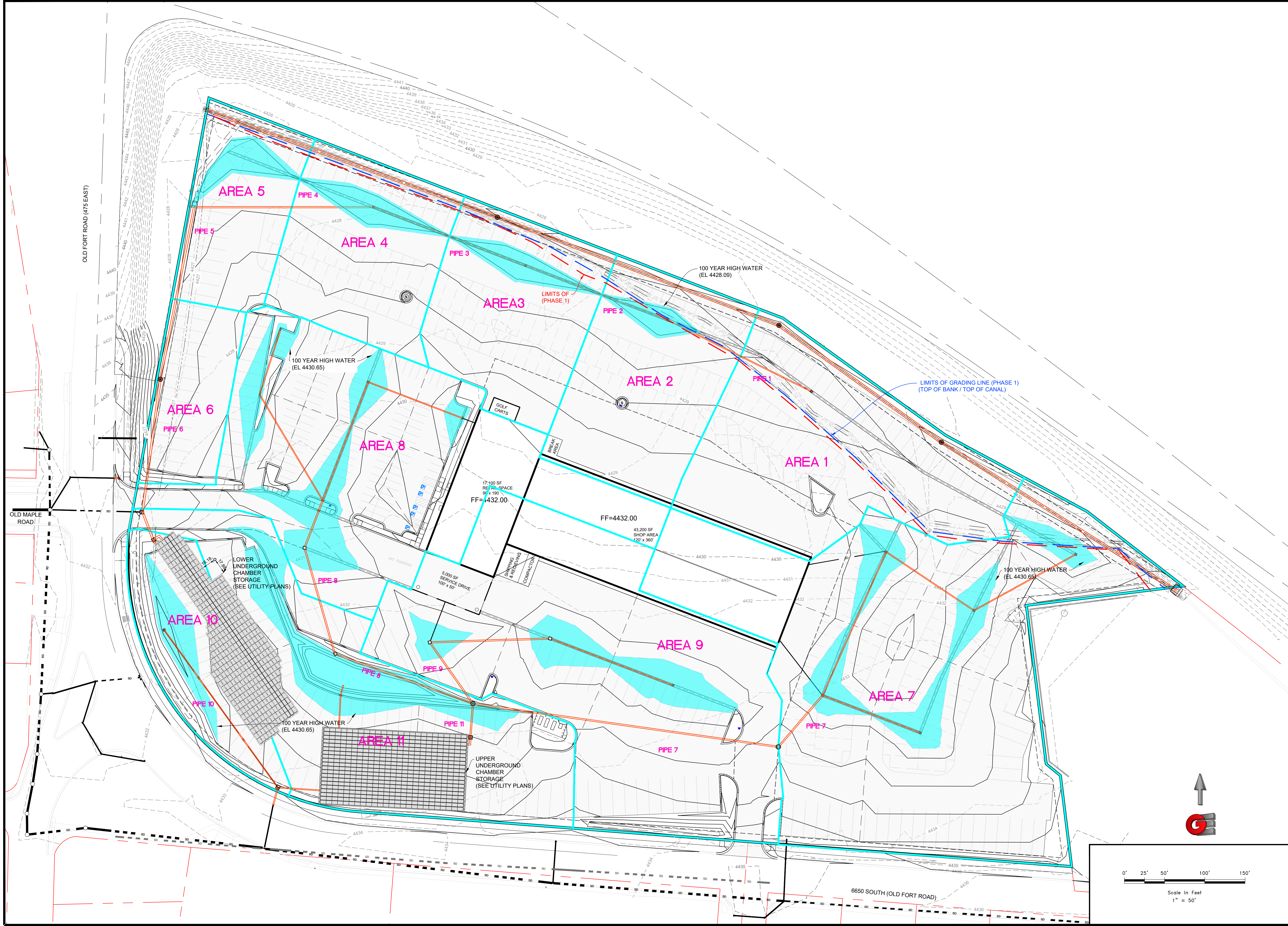

REVISIONS	DATE	DESCRIPTION

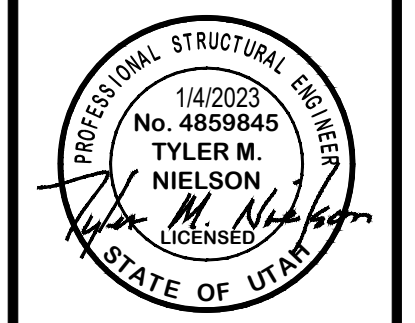

DRAINAGE CALCS
 RV GENERAL
 546 EAST OLD FORT ROAD
 SOUTH WEBER CITY, DAVIS COUNTY, UTAH

GARDNER ENGINEERING
 CIVIL • LAND PLANNING
 MUNICIPAL • LAND SURVEYING
 985 S CHAMBER ST, SUITE #5, OGDEN, UT 84405
 P. 801.476.0202 F. 801.476.0066

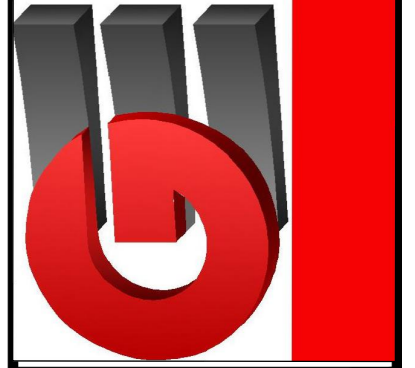

CE6-01

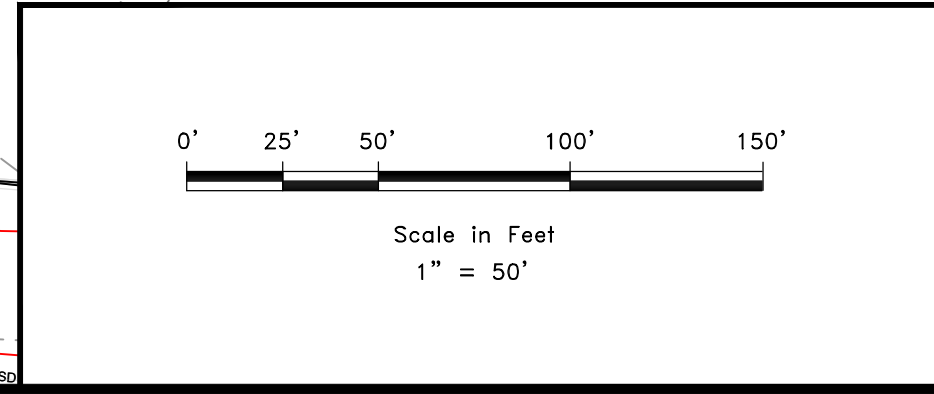

SCALE: 1" = 50'
 DATE: 1/4/2023
 DESIGN: WJS
 DRAWN: WJS
 CHECKED: TAN
 DWG: R.V. 1942 - SOUTH WEBER LLC, 2021 - GENERAL BY SOUTH WEBER DESIGN, DWG GRADING PLAN

RV General
South Weber City, Davis County, Utah

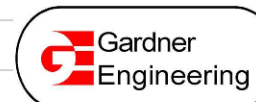

PIPE	CONTRIBUTING BASINS	CONTRIBUTING Area (AC)	REQUIRED 10 YR FLOW (cfs)	PIPE SIZE (in)	SLOPE (ft/ft)	Min. Pipe SLOPE %
1	1	1.68	2.20	18	0.00583	0.058
				15	0.00154	0.154
				12	0.002724	0.272
				10	0.007202	0.720
				8	0.023676	2.368
				6	0.109811	10.981
(Flows begin to pond and overflow to Area 2)						
Pipe here is undersized so water backs up and to facilitate drainage after the storm event						
2	1, 2	2.81	3.71	18	0.001652	0.165
				15	0.004368	0.437
				12	0.007721	0.772
				10	0.020417	2.042
				8	0.06712	6.712
				6	0.311309	31.131
(Flows begin to pond and overflow to Area 3)						
Pipe here is undersized so water backs up and to facilitate drainage after the storm event						
3	1, 2, 3	3.84	5.07	18	0.003082	0.308
				15	0.008151	0.815
				12	0.01441	1.441
				10	0.038102	3.810
				8	0.125258	12.526
				6	0.58096	58.096
(Flows begin to pond and overflow to Area 4)						
Pipe here is undersized so water backs up and to facilitate drainage after the storm event						
4	1, 2, 3, 4	4.83	6.38	18	0.004878	0.488
				15	0.012898	1.290
				12	0.022802	2.280
				10	0.060293	6.029
				8	0.198207	19.821
				6	0.919303	91.930
Localized low point into landscape with overflow going into 100 year sized pipe.						
5	1, 2, 3, 4, 5	5.51	6.89	42	6.22E-05	0.006
				36	0.000141	0.014
				30	0.000374	0.037
				24	0.001229	0.123
				18	0.003066	0.307
				15	0.015076	1.508
6	1, 2, 3, 4, 5, 6	6.00	7.47	42	7.3E-05	0.007
				36	0.000196	0.017
				30	0.000439	0.044
				24	0.001444	0.144
				18	0.003602	0.360
				15	0.017709	1.771
7	7	3.81	6.63	42	5.76E-05	0.006
				36	0.000131	0.013
				30	0.000346	0.035
				24	0.001139	0.114
				18	0.005281	0.528
				15	0.013963	1.396
8	8	2.48	4.84	42	3.07E-05	0.003
				36	6.98E-05	0.007
				30	9.93E-05	0.010
				24	0.000326	0.033
				18	0.001514	0.151
				15	0.004003	0.400
9	9	2.92	3.97	42	2.06E-05	0.002
				36	4.69E-05	0.005
				30	0.000124	0.012
				24	0.000407	0.041
				18	0.00189	0.189
				15	0.004997	0.500
10	10	0.72	1.04	36	3.23E-06	0.000
				30	8.53E-06	0.001
				24	2.8E-05	0.003
				18	0.00013	0.013
				15	0.000344	0.034
				12	0.001131	0.113
11	9, 11	4.97	7.57	42	7.49E-05	0.007
				36	0.000171	0.017
				30	0.000451	0.045
				24	0.001482	0.148
				18	0.008876	0.888
				15	0.018181	1.818

RV - General
South Weber City, Davis County, Utah
Ogden, Weber County, Utah



	Total Site		
	Sq. Ft.	Acres	C
Hard Surface	239,308	5.4937	0.90
Xeroscape Area	20,900	0.4798	0.30
Lawn Area	0	0.0000	0.10

Adjusted Allow Release Rate (cfs/acre)	0.100
Q Allowable (cfs)	0.60

Total/Weighted	260,208	5.9736	0.85
----------------	---------	--------	------

	CF	CY
100 YEAR STORM RECOMMENDED MIN. VOLUME DETAINED	33,800	1,252
Available 100 year Surface Volume Detained	3,205	119
Pipes and SD boxes volume	2,777	103
Underground Detention Required (443 SC-740 Chambers)	27,818	1,133
Total Storage Provided	33,800	

MIN	Runoff Vol (cf) Allowable	*Inch / Hr i100	Total Vol (cf) 100 YEAR	Detain Vol (cf) Difference
5	179	7.07	10,792	10,613
10	358	5.37	16,395	16,036
15	538	4.44	20,333	19,795
30	1,075	2.99	27,385	26,310
60	2,150	1.85	33,888	31,738
120	4,301	1.04	38,101	33,800
180	6,451	0.72	39,587	33,115
360	12,903	0.40	43,743	30,840
720	25,806	0.24	52,755	26,950
1440	51,612	0.14	61,548	9,937

NOAA Atlas 14

Control Box
Overall Site Orifice Calculation

H = 2.72 Maximum water height (ft)
 Q = 0.60 Flowrate out of orifice (cfs)
 Cc = 0.62 Coefficient of Contraction
 Cv = 0.98 Coefficient of Velocity
 Area = 0.074 Orifice Area (ft²)
 π = 3.14
 g = 32.17 Gravitational Constant
 d = 3.69 Orifice Diameter (in)
d = 3.6/8 Orifice

Lower Surface Ponding Area =	3205.17 CF
Pipe Storage (CF) =	1209.5132 CF
Pipe Storage (CF) =	394.07353 CF
Pipe Storage (CF) =	249.11848 CF
Pipe Storage (CF) =	464.95571 CF
TOTAL PIPE STORAGE (CF)	2317.6609 CF
Catch Basins	458.96 CF

Pipe Diameter (inches)	24	Pipe Length (feet)	385
Pipe Diameter (inches)	18	Pipe Length (feet)	223
Pipe Diameter (inches)	15	Pipe Length (feet)	203
Pipe Diameter (inches)	12	Pipe Length (feet)	592

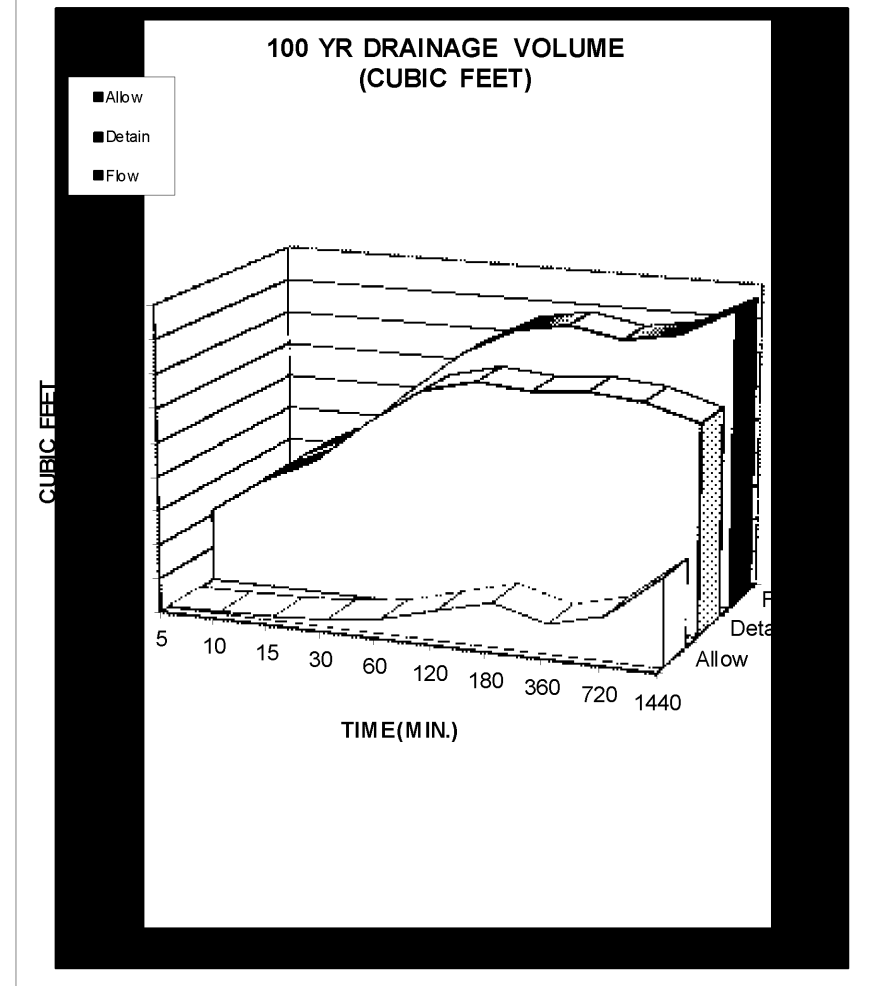

RV - General
South Weber City, Davis County, Utah
Ogden, Weber County, Utah



	Total Site		
	Sq. Ft.	Acres	C
Hard Surface	464,235	10.6573	0.90
Xeroscape Area	58,539	1.3439	0.30
Lawn Area	0	0.0000	0.10

Adjusted Allow Release Rate (cfs/acre)	0.100
Q Allowable (cfs)	1.20

Total/Weighted	522,774	12.0012	0.83
----------------	---------	---------	------

	CF	CY
100 YEAR STORM RECOMMENDED MIN. VOLUME DETAINED	66,200	2,452
Available 100 year Surface Volume Detained	24,583	910
Pipes and SD boxes volume	3,123	
Underground Detention Required (493 DC-780 Chambers)	38,494	1,541

MIN	Runoff Vol (cf) Allowable	*Inch / Hr i100	Total Vol (cf) 100 YEAR	Detain Vol (cf) Difference
5	360	7.07	21,199	20,839
10	720	5.37	32,203	31,483
15	1,080	4.44	39,939	38,859
30	2,160	2.99	53,792	51,632
60	4,320	1.85	66,565	62,245
120	8,641	1.04	74,841	66,200
180	12,961	0.72	77,719	64,758
360	25,923	0.40	85,923	60,000
720	51,845	0.24	103,626	51,780
1440	103,691	0.14	120,897	17,206

NOAA Atlas 14

Control Box
Overall Site Orifice Calculation

H = 4.22 Maximum water height (ft)
 Q = 1.20 Flowrate out of orifice (cfs)
 Cc = 0.62 Coefficient of Contraction
 Cv = 0.98 Coefficient of Velocity
 Area = 0.120 Orifice Area (ft²)
 π = 3.14
 g = 32.17 Gravitational Constant
 d = 4.69 Orifice Diameter (in)
d = 4.6/8 Orifice

Upper Surface Ponding Area = 24583.23 CF

Pipe Storage (CF) =	1705.2958 CF	Pipe Diameter (inches)	18	Pipe Length (feet)	965
Pipe Storage (CF) =	0 CF	Pipe Diameter (inches)	15	Pipe Length (feet)	0
Pipe Storage (CF) =	1145.1105 CF	Pipe Diameter (inches)	12	Pipe Length (feet)	1458
Pipe Storage (CF) =	57,246799 CF	Pipe Diameter (inches)	8	Pipe Length (feet)	164
TOTAL PIPE STORAGE (CF)	2907.6531 CF				
Catch Basins	215.12 CF				

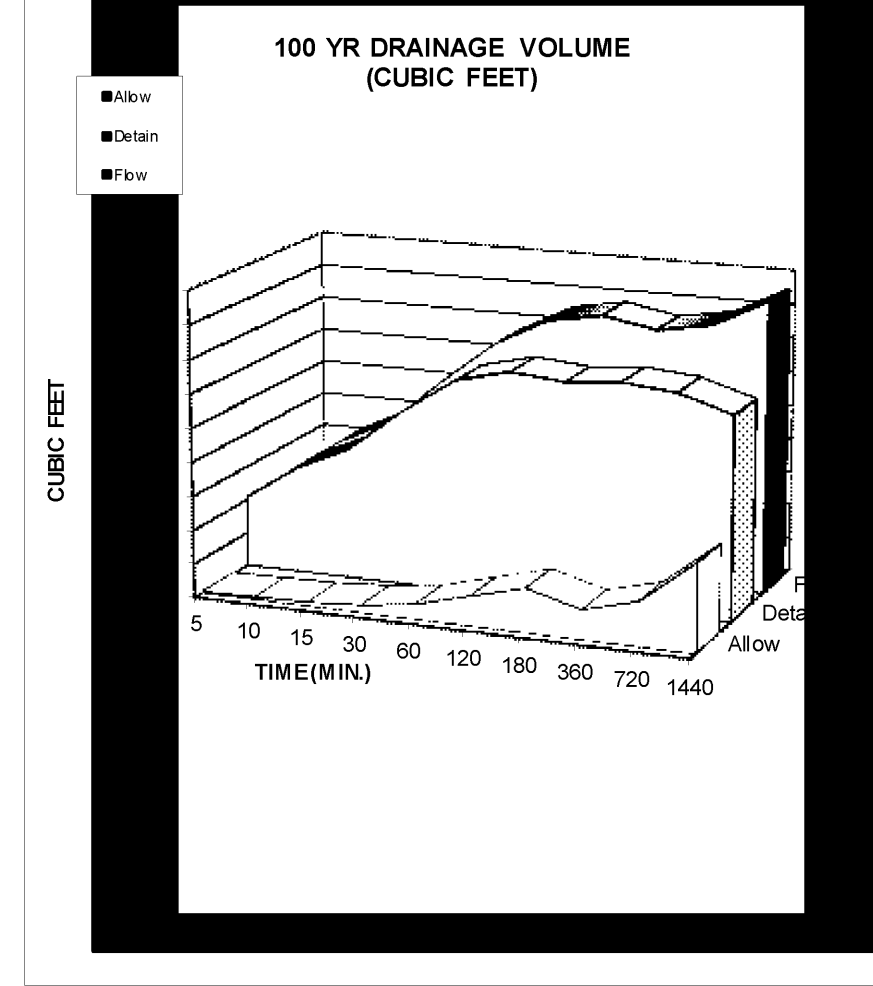

RV - General
South Weber City, Davis County, Utah
Ogden, Weber County, Utah



	Total Site		
	Sq. Ft.	Acres	C
Hard Surface	703,543	16.1511	0.90
Xeroscape Area	79,439	1.8237	0.30
Lawn Area	0	0.0000	0.10

Adjusted Allow Release Rate (cfs/acre)	0.100
Q Allowable (cfs)	1.80

Total/Weighted	782,982	17.9748	0.84
----------------	---------	---------	------

	CF	CY
100 YEAR STORM RECOMMENDED MIN. VOLUME DETAINED	100,000	3,704
Available 100 year Surface Volume Detained	27,788	1,029
Pipes and SD boxes volume	5,899	218
Min. Underground Detention Required and Provided	66,312	2,675
Total Provided Detention	100,000	3,704

MIN	Runoff Vol (cf) Allowable	*Inch / Hr i100	Total Vol (cf) 100 YEAR	Detain Vol (cf) Difference
5	539	7.07	31,991	31,452
10	1,078	5.37	48,598	47,519
15	1,618	4.44	60,272	58,654
30	3,235	2.99	81,177	77,942
60	6,471	1.85	100,453	93,982
120	12,942	1.04	112,942	100,000
180	19,413	0.72	117,286	97,873
360	38,826	0.40	129,666	90,840
720	77,651	0.24	156,381	78,730
1440	155,302	0.14	182,445	27,142

NOAA Atlas 14

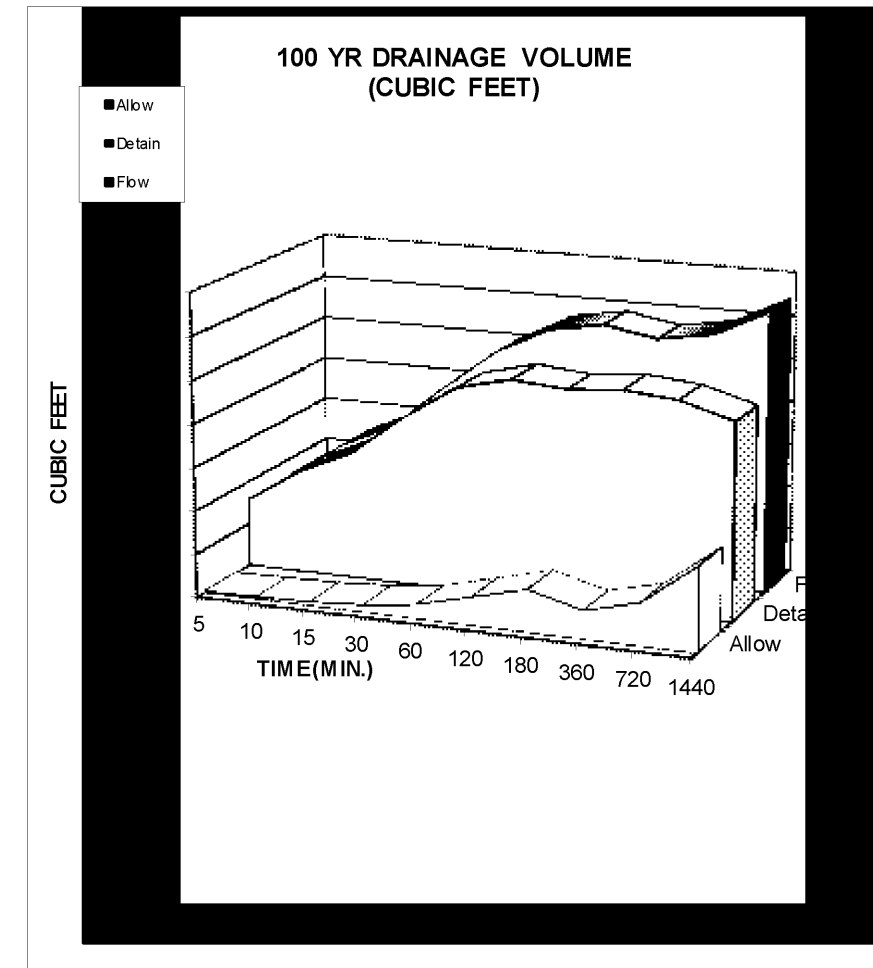

SCALE: N.T.S.	DATE: 1/4/2023	DESIGN: WJS	DRAWN: WJS	CHECKED: TAY
REVISIONS	DESCRIPTION	DATE		

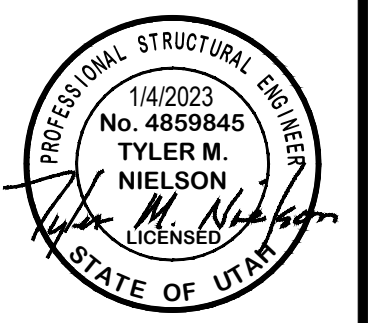

DRAINAGE CALCS
 RV GENERAL
 546 EAST OLD FORT ROAD
 SOUTH WEBER CITY, DAVIS COUNTY, UTAH

GARDNER ENGINEERING
 CIVIL - LAND PLANNING
 MUNICIPAL - LAND SURVEYING
 985 CHAMBERLAIN ST., SUITE #5, OGDEN, UT 84405
 P. 801.476.0202 F. 801.476.0066

CE6-02

**AGREEMENT REGARDING OWNERSHIP AND MAINTENANCE
OF
INFRASTRUCTURE AND LANDSCAPING**

This Agreement (“Agreement”) is made and entered into this ____ day of _____, 2023, (“Effective Date”) by and between **SOUTH WEBER CITY**, Utah, a municipal corporation (“City”) and **SOUTH WEBER LLC**, a Limited Liability Company (“Developer”). City and Developer are hereafter referred to individually as “Party” or collectively as “Parties.”

RECITALS

- A. Developer owns or controls real property located within the City and more particularly described on **Exhibit “A”** (“Property”).
- B. Developer wishes to develop or otherwise improve the Property into a commercial development known as General RV (“Development”).
- C. City and Developer desire to clearly establish long-term maintenance obligations relating to public and private infrastructure (water, sewer, storm drain, irrigation, and landscaping) located on the Property.

AGREEMENT

NOW, THEREFORE, and in consideration of the mutual covenants and agreements contained herein, the sufficiency of which is hereby acknowledged, City and Developer do mutually agree as follows:

- 1. **Incorporation of Recitals and Exhibits.** The foregoing Recitals and all Exhibits referenced herein are hereby incorporated and made part of this Agreement.
- 2. **Definitions.** As used in this Agreement, the words and phrases specified below shall have the following meanings:
 - a. “City” means South Weber City;
 - b. “Developer” means South Weber LLC;
 - c. “Development” refers to the Developer’s project to develop or otherwise improve the Property into a commercial development known as General RV;
 - d. “Infrastructure” refers to water, sewer, storm drain/storm water, irrigation, and landscaping infrastructure located on the Property and shown on **Exhibit “B;”**
 - e. “Property” means approximately 17.97 acres of real property located in South Weber City and described in **Exhibit “A;”**
 - f. “Right-of-Way” or “ROW” refers to the full public ownership of Old Fort Road and 475 East;
 - g. “Roadway” means the paved road area, including curb and gutter;

- h. “Storm Water Facilities” refers to interior lines, manholes, inlet boxes, detention and retention basins, and discharge lines up to and including the outlet control structures;
- 3. **Responsibility for Infrastructure:** Ownership and rights to real property, including such public utility easements as exist presently or shall be necessary for the Development, shall be governed by the Plat and/or Development Agreement that will be recorded against the property at such time as the Development obtains formal approval from the City in accordance with state law and municipal ordinances. This agreement establishes ownership and responsibility for water, sewer, storm drain/storm water, irrigation, and landscaping infrastructure (“Infrastructure”) located on the Property as shown on **Exhibit “B”** and further defined as follows:
 - a. **Water:**
 - i. City shall own the main line, tee, control valves at the two (2) connections servicing the Development, and the meter station.
 - ii. Developer shall own all interior lines, valves, fire hydrants, and services past the control valves in the Roadway.
 - b. **Sewer:**
 - i. The Central Weber Sewer Improvement District owns the main line and manholes in the Roadway.
 - ii. Developer shall own the service lateral, all interior lines, separator, and waste station dump.
 - c. **Storm Drain / Storm Water:**
 - i. City owns the main line, manholes, and inlet boxes in the Roadway.
 - ii. Developer shall own all interior lines, manholes, inlet boxes, detention and retention basins, and discharge lines up to and including the outlet control structures, hereinafter referred to as Storm Water Facilities.
 - d. **Landscaping:**
 - i. Developer shall own all landscaping within the Property and on the north and east sides within the ROW.
- 4. **Operation:** Each Party shall have full and complete responsibility to operate the Infrastructure that it owns, as such ownership is indicated in **Exhibit “B”** and described in section two (2) of this Agreement. The Parties mutually agree to operate and maintain their respective Infrastructure and all other related facilities in a state of good repair and in good faith. The Parties agree not to intentionally alter or inhibit the intended function of the Infrastructure in a way that negatively impacts the Infrastructure owned and maintained by the other Party. If

temporary adjustments to the Infrastructure are needed, the Parties agree to work together in a cooperative manner to the benefit of each Party.

- a. **Culinary Water Service:** City will provide culinary water to the Development and invoice the Developer for the water used per City Code – Title 8 Water, Sewer, Storm Water and Drainage, Chapter 1 Water Use and Services.
 - b. **Misuse of Culinary Water:** Developer hereby acknowledges that water provided to the fire hydrants located on the Property are for public, fire protection purposes and shall not be used for any purpose other than providing fire protection to the Development and surrounding properties. The City has an obligation to protect its water resources by punishing any improper or illegal use as allowed by state law or city code.
5. **Maintenance and/or Repair:** For the purposes of this Agreement, the terms maintenance or repair are defined to include any work required to keep the Infrastructure located on the Development performing its designed functions and in good working condition in accordance with manufacturer’s recommendations, where such recommendations are applicable. Each Party, at its sole cost and expense, shall be responsible for completing any maintenance work required on all Infrastructure owned by that Party. The Parties shall perform such maintenance according to the following additional requirements:
- a. **Culinary Water:**
 - i. The Developer shall provide the City twenty-four (24) hours’ notice if shut-off of service to the Development is required.
 - ii. Emergency or after-hours water-shut off shall be provided through the City’s on-call Public Works system.
 - iii. The Developer shall pay for all costs associated with repairs.
 - iv. Suspected Leak or Pipe Breakage. If the Developer or the City suspects a leak or defect in the water infrastructure owned by the Developer, the Developer agrees to repair said defect according to their responsibilities.
 1. Time Frame for Repair. Repair shall be completed within two (2) business days.
 2. Non-Emergency. In the event that such repair will require additional time, the Developer agrees to provide the City with a written plan for repair.
 3. Emergency. In the event of a major leak or a leak with the potential to cause damage to surrounding property, the responsible Party shall act immediately and notify the other Party within twenty-four (24) hours.
 4. Catastrophic Disaster. In the event of a catastrophic disaster, the City shall cooperate with the Developer to continue to furnish water to the Development. However, the City will fulfill its obligations to its citizens before water will be delivered to the Development.
 5. Enforcement. The City is hereby authorized to shut off water service to the Development for any non-compliance with the repair of leaks or pipe

breakage, after reasonable notice has been provided depending on the nature and magnitude of the leak or breakage.

b. Sewer:

- i. The Developer agrees to inspect and clean its sewer lines, separator, and waste station dump as often as is necessary to keep them in good working order.
- ii. If, as a result of video inspection, it is discovered that groundwater is infiltrating through leaks in the piping or other system facilities, the Developer shall promptly repair such leaks. Groundwater shall not be pumped or drained into sewer collection system through any other means.

c. Storm Drain / Storm Water: The City is authorized and required to regulate and control the disposition of storm and surface waters within the Small Municipal Separate Storm Sewer System, also known as the South Weber City Storm Drain System, (“Small MS4”), as set forth in the South Weber City Storm Water Ordinance, as amended, adopted pursuant to the Utah Water Quality Act, as set forth in *Utah Code Ann.* §§ 19-5-101, *et seq.*, as amended (“Act”).

- i. Annual Inspection and Maintenance Report Required: The Developer shall at its sole cost and expense, inspect all their storm drain facilities and submit an inspection report and certification to the City annually. The annual inspection shall cover all aspects of the Storm Water Facilities, including, but not limited to, the parking lots, structural improvements (*e.g.*, oil/water separators, underground infiltration galleries, and underground detention basins), berms, channels, outlet structure, pond areas, access roads, vegetation, landscaping, etc. Deficiencies shall be noted in the inspection report. The report shall also contain a certification as to whether adequate maintenance has been performed and whether the structural controls are operating as designed to protect water quality. The annual inspection report and certification shall be due by June 30th of each year and shall be on forms acceptable to the City. Inspections shall be performed by qualified personnel.
- ii. City Oversight Inspection Authority: The Developer hereby grants permission to the City, its authorized agents, or employees, to enter upon the Development and to inspect the Storm Water Facilities upon reasonable notice to the Developer or other on-site operator. Such inspections shall be conducted in a reasonable manner and at reasonable times, as determined appropriate by the City. The purpose of the inspection shall be to determine and ensure that the Storm Water Facilities are being adequately operated and maintained to meet the intent of the design, are continuing to perform in an adequate manner, and are in compliance with the Act, the Ordinance, and manufacturer’s recommendations, where applicable.
- iii. Notice of Deficiencies: If the City finds that the Storm Water Facilities contain any defects or are not being maintained adequately, the City shall send Developer written notice of the defects or deficiencies and provide Developer with a reasonable time, but not less than thirty (30) days, to cure such defects or

deficiencies. Such notice shall be confirmed delivery to the Developer or sent certified mail to the Developer at the address listed in Section 12 of this Agreement.

1. In the event the Developer fails to adequately maintain the Storm Water Facilities in good working condition acceptable to the City, after due notice of deficiencies as provided in the above paragraph and failure to cure, then the City shall send a second notice to the Developer. Upon Developer's failure to cure or correct within thirty (30) days following the second notice, the City may issue a Citation punishable as a Misdemeanor in addition to any State or EPA fine.
2. Upon the expiration of the thirty (30) days following the second notice, if the Developer fails to cure defects or deficiencies, the City shall have the authority to perform, or have performed, the necessary maintenance or corrective actions. It is expressly understood and agreed that the City is under no obligation to maintain or repair the Storm Water Facilities, and in no event shall this Agreement be construed to impose any such obligation on the City. The actions described in this Section are in addition to and not in lieu of any and all equitable remedies available to the City as provided by law for Developer's failure to remedy deficiencies or any other failure to perform under the terms and conditions of this Agreement.

d. Landscaping:

- i. Developer may allow existing natural vegetation to remain along the Interstate 84 right-of-way. Developer shall maintain all other vegetation on the Property so as not to create a risk of a natural or manmade fire, not to obstruct Roadway traffic or signs, and not to attract nuisance wildlife (e.g., rats, mice, lizards, snakes, insects, and spiders).
 - ii. Developer is responsible for maintaining all landscaping within the Development with secondary water, provided by the South Weber Irrigation Company. Culinary water will not be allowed to be used for landscaping irrigation purposes.
 - iii. Developer is responsible for maintaining all landscaping within the ROW along their property frontage.
 - iv. City shall monitor the landscaping and enforce violations as outlined in City Code Title 1 Administration, Chapter 10 Administrative Code Enforcement.
- e. **Recovery of Costs:** In the event the City, pursuant to this Agreement, incurs any costs, or expends any funds resulting from enforcement or for labor, use of equipment, supplies, materials, and the like related to correction of leaks, defects or deficiencies, the Developer shall reimburse the City upon demand, within thirty (30) days of receipt thereof for all actual costs incurred by the City. After said thirty (30) days, such amount

- shall be deemed delinquent and shall be subject to interest at the rate of ten percent (10%) per annum. Developer shall also be liable for any collection costs, including attorneys' fees and court costs, incurred by the City in collection of delinquent payments. City reserves the right to file a lien on the Property in the event of non-payment.
6. **Replacement:** For the purposes of this Agreement, Replacement shall be defined as any work associated with the removal and/or replacement of any portion of the on-site water, sewer, storm drain / storm water, irrigation, or landscaping facility or appurtenance associated with the Development as shown in **Exhibit "B."** Costs associated with removal and/or replacement shall be borne solely by the owner of the facility as defined in Section 3 above.
 7. **Limitations:** Except as outlined by this Agreement or by agreement separate from this, neither Party assumes any responsibility to inspect, install, operate or otherwise maintain the other Party's facilities. Further, this Agreement does not impose on either Party any duty, fees, inspections, or any other types of activity outside the scope of this Agreement.
 8. **Successors and Assigns:**
 - a. **Binding Effect:** This Agreement shall be binding upon the successors and assigns of the Parties.
 - b. **Assignment:** Neither this Agreement nor any of its provisions, terms or conditions may be assigned to any other Party, individual, or entity without assigning the rights as well as responsibilities under this Agreement and without the prior written consent of the City, which consent shall not be unreasonably withheld. Any such request for assignment shall be made in writing, and written consent of the City evidenced.
 9. **Default:** In the event either Party fails to perform its obligations hereunder or to comply with the terms and commitments hereof, within thirty (30) days after having been given written notice or default from the other Party, the non-defaulting Party may, at its election, have the following remedies, which shall be cumulative:
 - a. All rights and remedies available at law and in equity, including but not limited to injunctive relief, specific performance, and/or damages;
 - b. To cure such default or enjoin such violation and otherwise enforce the requirements contained in this Agreement; and
 - c. The right to withhold all further approvals, licenses, permits, or other rights associated with any activity or development described in this Agreement until such default is cured.
 10. **Insolvency:** Insolvency, bankruptcy, or any voluntary or involuntary assignment by any Party for the benefit of creditors, which action is unresolved for a period of one hundred and eighty (180) days, shall be deemed to be a default by such Party under this Agreement.
 11. **Court Costs and Attorney's Fees:** In the event of any legal action or defense between the Parties arising out of or related to this Agreement or any of the documents provided for herein,

the prevailing Party or Parties shall be entitled, in addition to the remedies and damages, if any awarded in such proceedings, to recover their costs and reasonable attorneys' fees.

12. **Notices:** Any notices, requests and demands required or desired to be given hereunder shall be in writing and shall be served personally upon the Party for whom the intended, or if mailed, be by certified mail, return receipt requested, postage prepaid, to such Party at:

Developer: South Weber LLC
25000 Assembly Park
Wixom, MI 48393

City: South Weber City
Attn: City Manager
1600 E. South Weber Drive
South Weber, UT 84405

Any Party may change its address or notice by giving written notice to the other Party in accordance with the provisions of this section.

13. **General Terms and Conditions:**

- a. **Amendments:** Any alterations or change to this Agreement shall be made only after complying with any applicable notice and hearing provisions of MLUDMA and applicable provisions of City Laws.
- b. **Term and Renewal:** Notwithstanding anything to the contrary in this Agreement, the obligations set forth in the Agreement shall remain in effect without limitation as to time.
- c. **Agreement to Run with the Land:** This Agreement shall be recorded in the office of the Davis County Recorder against the Development and is intended to and shall be deemed to run with the land and shall be binding on and inure to the benefits of the Parties hereto and their respective successors and assigns. This Agreement shall be constructed in accordance with the City Laws. Any action brought in connection with this Agreement shall be brought in a court of competent jurisdiction located in Davis County, Utah.
- d. **Legal Representation:** Each of the Parties hereto acknowledge that they each have been represented by legal counsel in negotiating this Agreement and that no Party shall have been deemed to have been the drafter of this Agreement.
- e. **Non-Liability of City Officials:** No officer, representative, agent, or employee of the City shall be personally liable to any other Party hereto or any successor in interest or assignee of such Party in the event of any default or breach by the defaulting Party, or for any amount which may become due the non-defaulting Party, its successors or assigns, or for any obligation arising under the terms of this Agreement.
- f. **Entire Agreement.** This Agreement, together with the exhibits hereto, integrates all of the terms and conditions pertaining to the subject matter hereof and superseded all prior

negotiations, representations, promises, inducements, or previous agreements between the Parties hereto with respect to the subject matter hereof. Any amendments hereto must be in writing and signed by the respective Parties hereto.

- g. **No-Third Party Rights:** The obligations of the Parties are set forth in this Agreement shall not create any rights in or obligations to any person or parties other than the Parties named herein. The Parties alone shall be entitled to enforce or waive any provisions of this Agreement to the extent that such provisions are for their benefit.
- h. **Force Majeure:** Any prevention, delay or stoppage of the performance of any obligation under this Agreement which is due to strikes, labor disputes, inability to obtain labor, materials, equipment or reasonable substitutes thereof, acts of nature, government restrictions, regulations or controls, judicial orders, enemy or hostile government actions, war, civil commotions, fire, floods, earthquakes or other casualties or other causes beyond the reasonable control of the Party obligated to perform hereunder, shall excuse performance of the obligation by that Party for a period equal to the duration of that prevention, delay or stoppage. Any Party seeking relief under the provisions of this paragraph must have noticed the other Party in writing of a force majeure event within thirty (30) days following occurrence of the claimed force majeure event.
- i. **Severability:** Should any portion of this Agreement for any reason be declared invalid or unenforceable, the invalidity or unenforceability of such portion shall not affect the validity of any of the remaining portions, and the same shall be deemed in full force and effect as if this Agreement had been executed with the invalid portions eliminated.
- j. **Waiver:** No waiver of any of the provisions of this Agreement shall operate as a waiver of any other provisions regardless of any similarity that may exist between such provisions, nor shall a waiver in one instance operate as a waiver in any future event. No waiver shall be binding unless executed in writing the waiving Party.
- k. **Governing Law:** This Agreement and the performance hereunder shall be governed by the laws of the State of Utah.
- l. **Exhibits:** Any exhibit to this Agreement is incorporated herein by this reference, and failure to attach any such exhibit shall not affect the validity of this Agreement or of such exhibit.

IN WITNESS WHEREOF, the Parties hereto have executed this Agreement by and through their respective duly authorized representatives as of the day and year first written above.

“Developer”
SOUTH WEBER LLC

By: _____

Title: _____

Witness the hand of said grantors, this _____ day of _____ 2023.

South Weber LLC

State of Utah)

) ss.

County of Davis)

On this _____ day of _____ 2023, personally appeared before me,

_____ ,

the signer of the foregoing instrument, who duly acknowledged that he/she is the

_____ of South Weber LLC by Authority of its Bylaws or Resolution of its
Board of

Directors, and said _____ acknowledged to me said Limited Liability
Company

executed the same.

WITNESS by hand and official seal the day and year of this certificate first above written.

NOTARY PUBLIC
Commission Expires:

“City”
SOUTH WEBER CITY

By: _____
David J. Larson, City Manager

ATTEST:

APPROVED AS TO FORM AND COMPLIANCE
WITH APPLICABLE LAW:

Lisa Smith, City Recorder

City Attorney

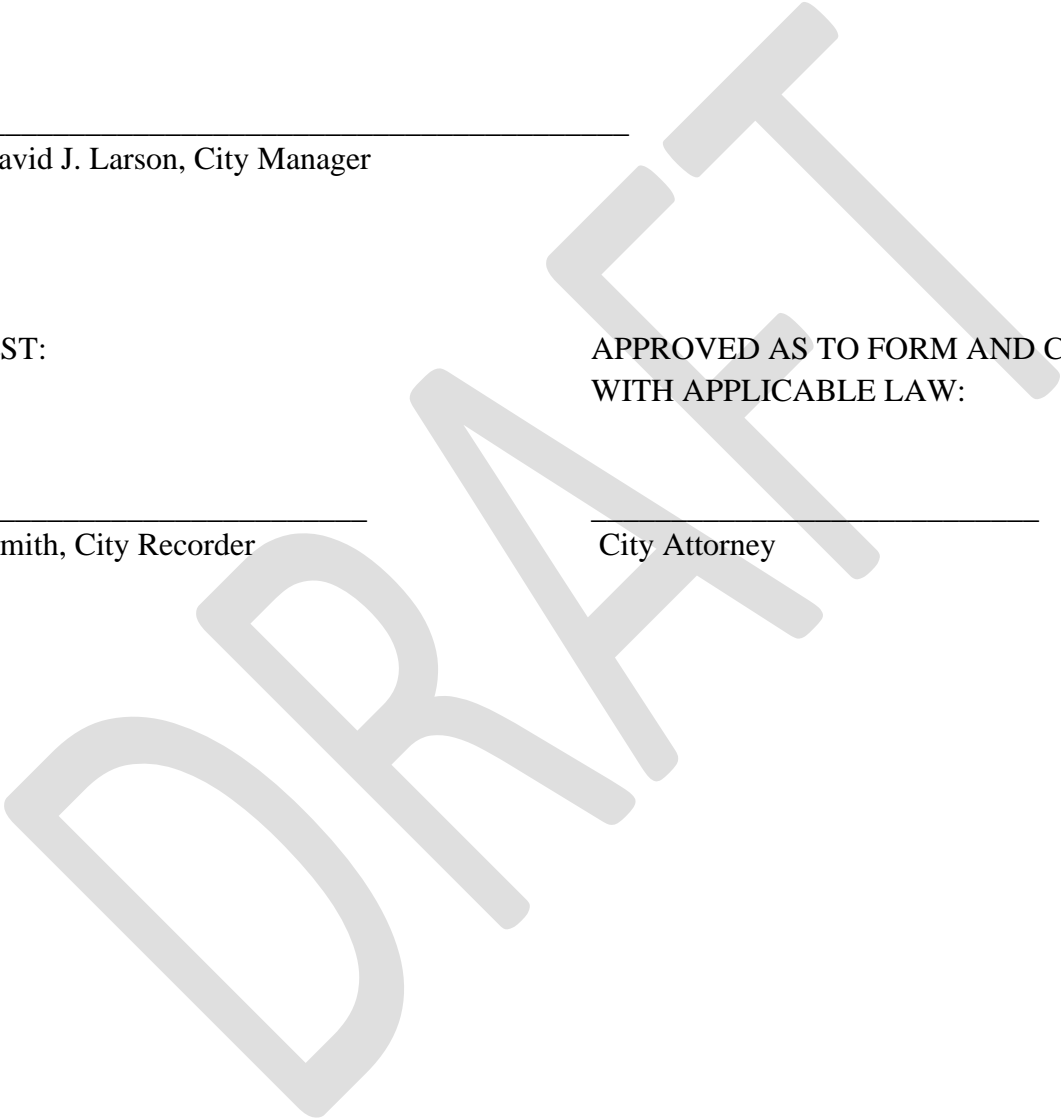

EXHIBIT A

PROPERTY BOUNDARY DESCRIPTION

A PART OF THE NORTHWEST QUARTER OF SECTION 28, THE NORTHEAST QUARTER OF SECTION 29, THE SOUTHEAST QUARTER OF SECTION 20 AND THE SOUTHWEST QUARTER OF SECTION 21, TOWNSHIP 5 NORTH, RANGE 1 WEST OF THE SALT LAKE BASE AND MERIDIAN, MORE PARTICULARLY DESCRIBED AS FOLLOWS:

BEGINNING AT A POINT ON THE NORTH LINE OF THE NORTHEAST QUARTER OF SAID SECTION 29, BEING LOCATED NORTH 89°07'40" WEST 108.08 FEET (BASIS OF BEARING BEING THE NORTH LINE OF THE NORTHEAST QUARTER OF SAID SECTION 29 WHICH BEARS NORTH 89°07'40" WEST NAD 83 STATE PLANE GRID BEARING) FROM THE NORTHEAST QUARTER OF SAID SECTION, SAID POINT BEING ON THE EAST RIGHT-OF-WAY LINE OF 475 EAST; RUNNING THENCE ALONG SAID RIGHT-OF-WAY LINE NORTH 00°29'39" EAST 31.52 FEET; THENCE CONTINUING ALONG SAID RIGHT-OF-WAY LINE NORTH 10°30'37" EAST 550.17 FEET TO THE SOUTHERLY RIGHT-OF-WAY LINE OF INTERSTATE 84; THENCE ALONG SAID RIGHT-OF-WAY LINE THE FOLLOWING FOUR (4) COURSES: (1) SOUTH 69°00'40" EAST 764.48 FEET; (2) SOUTH 54°14'40" EAST 249.65 FEET; (3) SOUTH 61°40'56" EAST 199.87 FEET; (4) SOUTH 52°09'21" EAST 151.07 FEET; THENCE SOUTH 82°57'31" WEST 196.36 FEET; THENCE SOUTH 07°07'49" EAST 198.86 FEET; THENCE SOUTH 50°41'10" EAST 22.70 FEET; THENCE SOUTH 07°02'29" EAST 114.17 FEET TO THE RIGHT-OF-WAY LINE OF OLD FORT ROAD; THENCE ALONG SAID RIGHT-OF-WAY THE FOLLOWING THREE (3) COURSES: (1) NORTH 85°35'49" WEST 889.13 FEET; (2) ALONG THE ARC OF A CURVE TO THE RIGHT 466.96 FEET, HAVING A RADIUS OF 311.00 FEET, A CENTRAL ANGLE OF 86°01'41", AND WHICH CHORD BEARS NORTH 42°34'59" WEST 424.31 FEET; (3) NORTH 02°29'39" EAST 3.15 FEET TO THE POINT OF BEGINNING.

CONTAINING 17.97 ACRES.



SCALE:
1" = 150'

UTILITY LEGEND PRIVATE OWNERSHIP:

- SS --- EXISTING SEWER (CWSID)
- SS --- PROPOSED SEWER (PRIVATE)
- IRR --- EXISTING IRRIGATION (SWIC)
- IRR --- PROPOSED IRRIGATION (PRIVATE)
- W --- EXISTING CULINARY WATER (SWC)
- W --- PROPOSED CULINARY WATER (PRIVATE)
- SD --- EXISTING STORM DRAIN (SWC)
- SD --- PROPOSED STORM DRAIN (PRIVATE)

NOTES:

1. DEVELOPER SHALL OWN THE LANDSCAPING WITHIN THE PROPERTY AND WITHIN THE RIGHT-OF-WAY ON THE NORTH AND WEST SIDES OF OLD FORT ROAD AND 475 EAST.
2. UDOT IS THE OWNER OF ALL PROPERTY WITHIN THE I-84 RIGHT-OF-WAY.

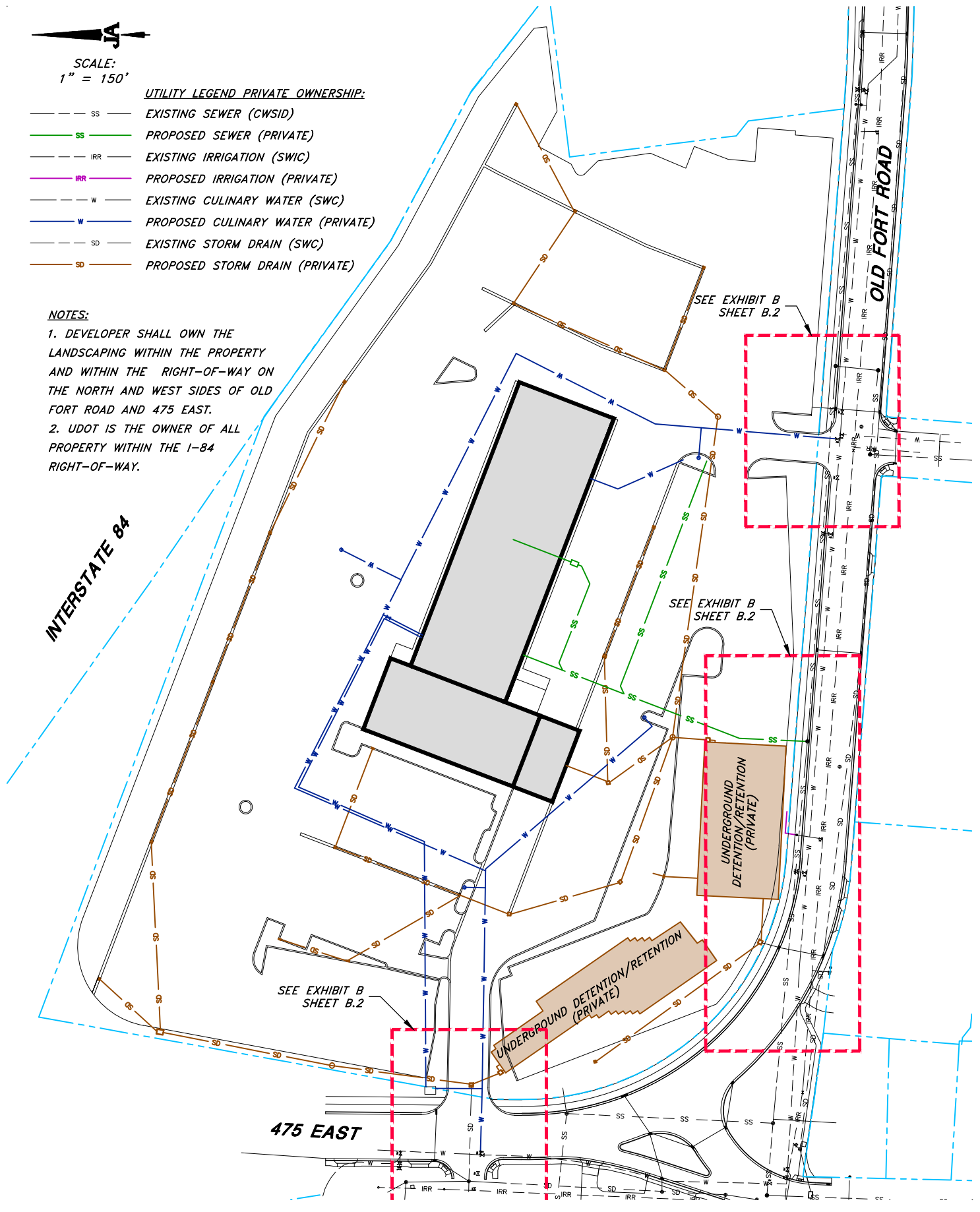

CONSULTING ENGINEERS
 6080 Fashion Point Drive South Ogden, Utah 84403
 (801) 476-9767 www.jonescivil.com

OWNERSHIP AND MAINTENANCE AGREEMENT
OVERALL OWNERSHIP EXHIBIT
EXHIBIT B

SHEET:
B.1
OF 1 SHEETS
0



SCALE:
1" = 50'

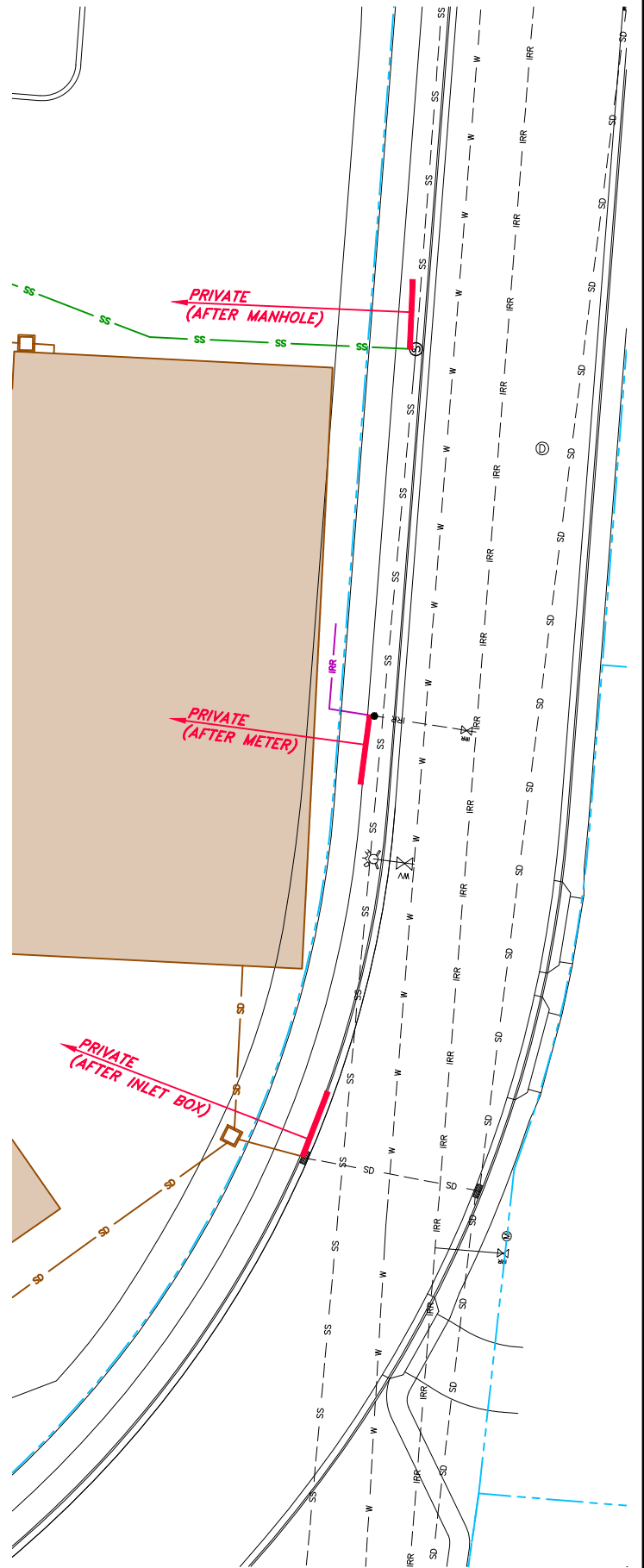
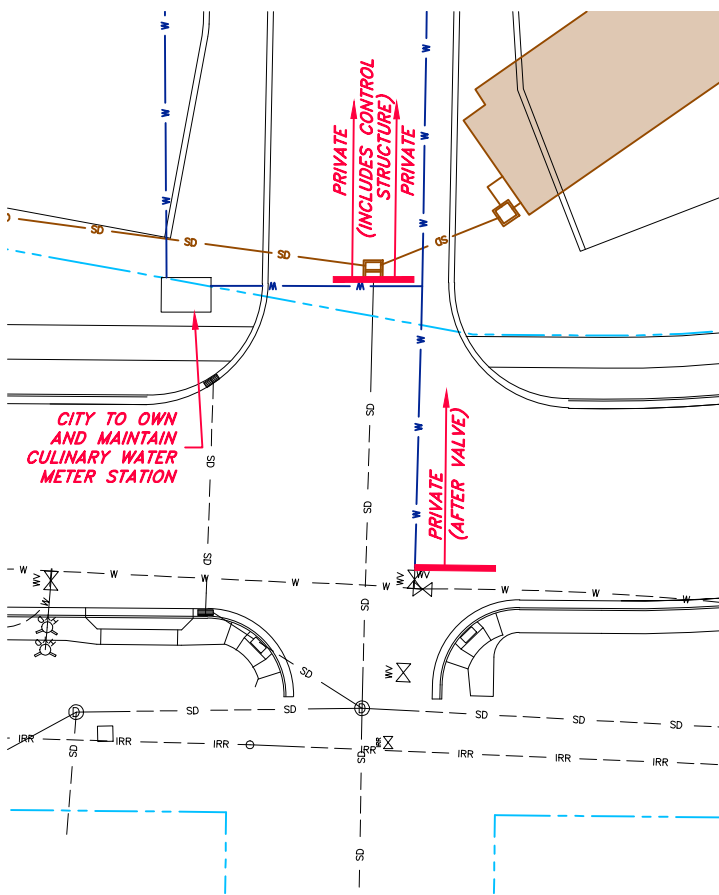
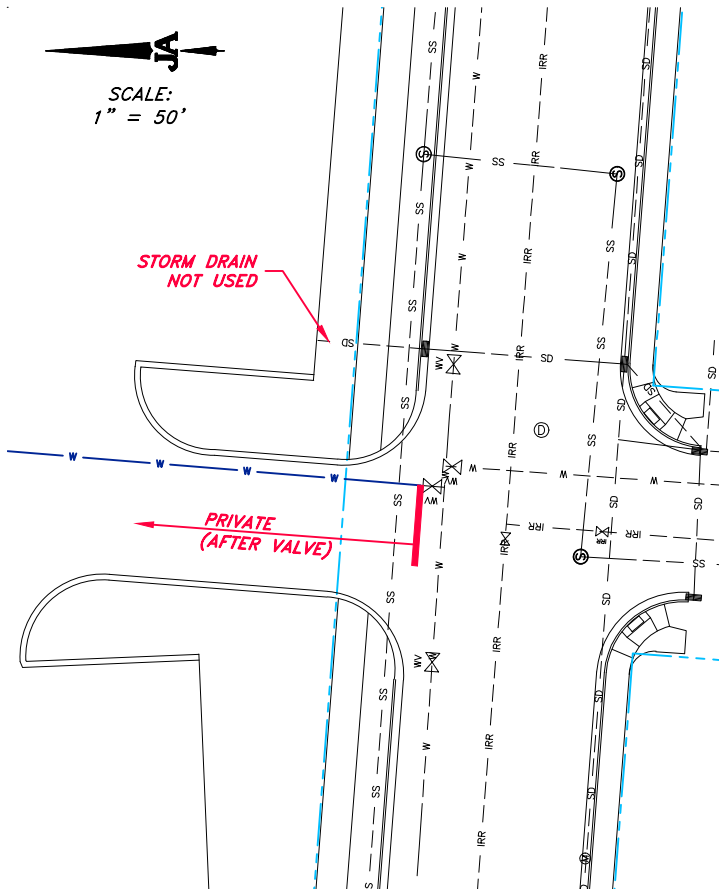

CONSULTING ENGINEERS

6080 Fashion Point Drive South Ogden, Utah 84403

(801) 476-9767 www.jonescivil.com

OWNERSHIP AND MAINTENANCE AGREEMENT

OWNERSHIP DETAIL

EXHIBIT B

SHEET:

B.2

OF 1 SHEETS

0