

SOUTH WEBER CITY COUNCIL AGENDA

PUBLIC NOTICE is hereby given that the **City Council of SOUTH WEBER CITY**, Utah, will meet in a regular public meeting on **Tuesday, 24 October 2017** at the **City Council Chambers, 1600 E. South Weber Dr.**, commencing at **6:00 p.m.**

WORK MEETING:

5:00 p.m. Discussion of agenda items, correspondence, and/or future agenda items.

COUNCIL MEETING:

6:00 p.m. PLEDGE OF ALLEGIANCE – Council Member
PRAYER - Council Member
APPROVAL OF AGENDA
DECLARATION OF CONFLICT OF INTEREST

1. CONSENT AGENDA:

◆ Approval of October 10, 2017 Work Meeting and Meeting Minutes

6:35 p.m.

La Roca Futbol Club Introduction and Grand Opening Invitation, Tim Wheelwright

2. ACTIVE AGENDA:

- a. **RES 17-40** Development, Design, & Construction Standards and Public Works Standard Drawings
- b. **ORD 17-18** Amending Subsections 11.06 Impact Fees: Sewer (taking effect end of Nov.)
- c. **ORD 17-19** Amending Subsection 11.06 Impact Fees: Parks (taking effect end of Dec.)
- d. Replace the hydraulic ram on the 2003 Snowplow Truck for \$5,850.37
- e. “Save the Barn” – Discussion on historic Canyon Meadows Barn by Tim Grubb

7:45 p.m.

3. PUBLIC COMMENT: Please keep public comments to 3 minutes or less per person (no action to be taken)

7:55 p.m.

4. REPORTS:

- a. Mayor – on designated committee responsibilities
- b. City Council – on designated committee responsibilities
- c. City Manager – on current events and future agenda items
- d. Planning Commission Liaison – meeting and current development update

8:00 p.m.

5. ADJOURN

THE UNDERSIGNED DULY APPOINTED CITY RECORDER FOR THE MUNICIPALITY OF SOUTH WEBER CITY HEREBY CERTIFIES THAT A COPY OF THE FOREGOING NOTICE WAS MAILED, EMAILED, OR POSTED TO:

CITY OFFICE BUILDING

EACH MEMBER OF THE GOVERNING BODY

UTAH PUBLIC NOTICE WEBSITE

CITY WEBSITE www.southwebercity.com

THOSE LISTED ON THE AGENDA

www.pmn.utah.gov

DATE: October 19, 2017

CITY RECORDER: Mark McRae

IN COMPLIANCE WITH THE AMERICANS WITH DISABILITIES ACT, INDIVIDUALS NEEDING SPECIAL ACCOMMODATIONS DURING THIS MEETING SHOULD NOTIFY THE CITY RECORDER, 1600 EAST SOUTH WEBER DRIVE, SOUTH WEBER, UTAH 84405 (801-479-3177) AT LEAST TWO DAYS PRIOR TO THE MEETING.

Agenda times are approximate and may be moved in order, sequence and time to meet the needs of the Council

SOUTH WEBER CITY COUNCIL WORK MEETING

DATE OF MEETING: 10 October 2017

TIME COMMENCED: 5:02 p.m.

PRESENT: MAYOR:

Tammy Long

COUNCILMEMBERS:

**Scott Casas
Kent Hyer (excused)
Jo Sjoblom
Merv Taylor
Wayne Winsor (excused)**

CITY MANAGER:

Tom Smith

CITY ENGINEER:

Brandon Jones

Transcriber: Minutes transcribed by Michelle Clark

VISITORS: Mark Larsen (Public Works Director)

Mayor Long excused Council Member Winsor and Hyer from tonight's meetings.

CONSENT AGENDA:

- **Approval of September 26, 2017 Work Meeting and Meeting Minutes**
- **Approval of September 2017 Check Register**
- **RESOLUTION 17-37 Appointment of City Finance Director/Recorder**

Mayor Long asked if there were any questions with the minutes. There were none. She asked if there were any questions with the check register. Tom said this register includes Country Fair Days. Mayor Long asked if the council if they have any questions concerning Resolution 17-37. Council Member Casas is concerned about and would like to know what led to the decision with not replacing the City Recorder. Tom said the Court Clerk will take over some of the City Recorder duties. He said the other office assistants will be taking over other duties. He said he would like to try this until at least the first of the year. He feels confident that these individuals will be able to handle the work. Council Member Sjoblom said she and Council Member Winsor discussed this in the Administration Committee meeting and feel good about it.

ACTIVE AGENDA:

Parks and Recreation Needs Assessment – Martin Jensen: Mayor Long said this item will be moved to the next agenda as Mr. Jensen was not able to attend tonight's meeting.

ORDINANCE 17-15 Amendment to Code Section 11.04 Improvement Requirements

Brandon Jones, City Engineer, said he sent a memo and the text revisions for Ordinance 17-15 to the Council. He said the text now reads in chronological order. He said the City Staff are responsible for administering and ensuring that the City Code is followed. This is particularly critical when it comes to the development process. Over the past several years the City has seen a significant increase in development activities. As the Staff has applied and enforced the code, there have been a few elements that have shown to be problematic or

unreasonable in administering or enforcing. Although there are other areas of the Code that potentially need some revision, the Staff recommends the following changes/clarifications to Section 11.04 (Improvements Requirements). These changes primarily apply to the construction and acceptance portion of the Code. There are no requirements being removed. The changes apply as it relates to the timing of required improvements. He said on 14 September 2017 the Planning Commission reviewed the amendments and recommended the City Council approve. Council Member Casas is concerned because he feels the City is being less restrictive and feels the City is going backward. Brandon said the recommendations being suggested are now in the way that construction actually happens. He went on to explain the development process. Council Member Casas interprets this as the City having more burden and not the developer. Brandon said burdens have not changed at all, but the timing of things has changed. Tom feels there are less steps because they get checked off in bulks verses every little thing. He said the incentive for the developer is to do it so they can get their escrow money back. Council Member Casas stated some of the street lights in the City are owned by Rocky Mountain Power some are owned by the City. Mark Larsen said in the future the City would like to turn all the street lights over to Rocky Mountain Power. Council Member Casas said three years ago when he did a street light study, it was three times cheaper for the City to repair the street lights verses Johnson Electric to repair it; however, the City pays Rocky Mountain Power to maintain the street lights. Brandon explained that with this ordinance the City will be responsible to request the street lights verses the developer. He said all of the lights will be LED. He said none of the amendments he is suggesting harms the City in any way or puts them at risk. He said developers will still need to complete the ordinance requirements.

ORDINANCE 17-10 Amendment to Code Section 3.01.090 Inspections and Chapter 3.09 Mobile

Businesses: Tom Smith, City Manager, said the State Legislature has updated Utah Code with the Food Truck Licensing and Regulation Act (UCA 11-56) effective 9 May 2017. The City staff has updated the Mobile Business Ordinance in City Code to comply with State requirements and has found areas for improvement with the existing code. Tom said concerning 3.01.90 the language has been changed for mobile food vendor. He said the definition of mobile businesses has been changed to mobile vendor. Tom said there is a fee associated if the vendor wants electricity and water on City property. He said a mobile vendor needs a business license from at least one city that can transfer to other cities.

RESOLUTION 17-32 Amendment to Consolidated Fee Schedule Chapter 6:4. Mobile Businesses

Tom said the fees for Chapter 6: Business Licenses are as follows:

4. Mobile Businesses

- A. License \$50
- B. Use Permit \$40
- C. Special Event Permit \$30
- D. Food Truck Permit \$30

Council Member Casas asked if there has been an interest in our city. Tom said yes.

Market Adjustment to Fire Chief Position: Tom said this item was discussed at the last Council meeting. The increase would go from \$23,400 to \$39,000 per year. An amendment would be made to the budget in June 2018. Tom would like to see the pay increase take place immediately. He said he is pushing this item because he wants to hold the same standard of service if this Fire Chief were to leave. Council Member Casas said the level of service far exceeded his expectations. He said this summer was catastrophic and feels it could have been a lot worse. He said the individual made that position well. Council Member Sjoblom said in comparison to similar positions, the staff recommendation is well within that range. She agrees with staff recommendation. Mayor Long asked if the Council would like to wait to make a decision so that Council Member Winsor and Hyer can be here. Council Member Casas said they have every opportunity to be to this meeting.

Adjourned at 6:00 p.m.

APPROVED: _____ Date
Mayor: Tammy Long

Transcriber: Michelle Clark

Attest: _____
City Manager: Tom Smith

DRAFT

SOUTH WEBER CITY CITY COUNCIL MEETING

DATE OF MEETING: 10 October 2017

TIME COMMENCED: 6:01 p.m.

PRESENT: MAYOR:

Tammy Long

COUNCILMEMBERS:

Scott Casas
Kent Hyer (excused)
Merv Taylor
Jo Sjoblom
Wayne Winsor (excused)

CITY MANAGER:

Tom Smith

Transcriber: Minutes transcribed by Michelle Clark

ATTENDEES: Mark Larsen (Public Works Director), Tim Grubb, Val Petersen, and John Grubb.

Mayor Long called the meeting to order and excused Council Member Hyer and Winsor from tonight's meeting.

PLEDGE OF ALLEGIANCE: Council Member Casas

PRAYER: Council Member Taylor

AGENDA: Council Member Sjoblom moved to approve the agenda as written. Council Member Casas seconded the motion. Tom called for the vote. Council Members Casas, Taylor, and Sjoblom voted yes. The motion carried.

CONFLICT OF INTEREST: None

QUARTERLY REPORT: Public Works Department: Mark Larsen, Public Works Director, reported that 1250 East is in the final punch list stage. He said Cottonwood Drive has been completed. He said Uintah citizens called to thank the City. Riverside Place Subdivision has taken out three building permits. Old Maple Farms Subdivision is installing asphalt. Tom said the City Staff will dead end 6650 South when Silver Oak Lane is connected to 6650 South. Brandon said it is looking like that will happen in the spring because of weather. Hidden Valley Meadows Subdivision is currently installing asphalt. Mark said if anyone has anything they would like to see in the quarterly report, please send him an email. Council Member Casas is concerned about the storage of salt. Brandon said given the importance of other items, this winter they will be researching the possibility of relocating the city shops. Brandon doesn't feel the City is in any kind of danger as they are looking at options for salt storage.

CONSENT AGENDA:

- **Approval of September 26, 2017 Work Meeting and Meeting Minutes**
- **Approval of September 2017 Check Register**
- **RESOLUTION 17-37 Appointment of City Finance Director/Recorder**

Council Member Taylor moved to approve the consent agenda as written. Council Member Sjoblom seconded the motion. Tom called for the vote. Council Members Casas, Taylor, and Sjoblom voted yes. The motion carried.

ACTIVE AGENDA:

Parks and Recreation Needs Assessment – Martin Jensen: *(This item will be moved to the next City Council agenda)*

ORDINANCE 17-15 Amendment to Code Section 11.04 Improvement Requirements

The City Staff are responsible for administering and ensuring that the City Code is followed. This is particularly critical when it comes to the development process. Over the past several years the City has seen a significant increase in development activities. As the Staff has applied and enforced the code, there have been a few elements that have shown to be problematic or unreasonable in administering or enforcing. Although there are other areas of the Code that potentially need some revision, the Staff recommends the following changes/clarifications to Section 11.04 (Improvements Requirements). These changes primarily apply to the construction and acceptance portion of the Code. There are no requirements being removed. The changes apply as it relates to the timing of required improvements.

Council Member Sjoblom moved to approve ORDINANCE 17-15 Amendment to Code Section 11.04 Improvement Requirements. Council Member Casas seconded the motion. Tom called for the vote. Council Members Casas, Taylor, and Sjoblom voted yes. The motion carried.

ORDINANCE 17-10 Amendment to Code Section 3.01.090 Inspections and Chapter 3.09

Mobile Businesses: Tom said the State Legislature has updated Utah Code with the Food Truck Licensing and Regulation Act (UCA 11-56) effective 9 May 2017. The City staff has updated the Mobile Business Ordinance in City Code to comply with State requirements and has found areas for improvement with the existing code.

Council Member Taylor moved to approve ORDINANCE 17-10 Amendment to Code Section 3.01.090 Inspections and Chapter 3.09 Mobile Businesses. Council Member Sjoblom seconded the motion. Tom called for the vote. Council Members Casas, Taylor, and Sjoblom voted yes. The motion carried.

RESOLUTION 17-32 Amendment to Consolidated Fee Schedule Chapter 6:4. Mobile

Businesses: The following are the amendments:

Chapter 6: Business Licenses

4. Mobile Businesses

A. License \$50

B. Use Permit \$40

- C. Special Event Permit \$30
- D. Food Truck Permit \$30

Council Member Casas moved to approve RESOLUTION 17-32 Amendment to Consolidated Fee Schedule Chapter 6:4. Mobile Businesses. Council Member Sjoblom seconded the motion. Tom called for the vote. Council Members Casas, Taylor, and Sjoblom voted yes. The motion carried.

Market Adjustment to Fire Chief Position: Tom Smith, City Manager, said in the last Council meeting it was discussed to make a market adjustment to the Fire Chief position. He would like to keep the same level of service should this Fire Chief move on. He would like the market wage to be competitive. It would also change the pay from hourly to salary. He said it will go from \$15 per hour \$23,400 per year to \$25 per hour to \$39,000 per year. This position will not be receiving benefits.

Council Member Taylor moved to approve the Market Adjustment to Fire Chief Position. Council Member Casas seconded the motion. Tom called for the vote. Council Members Casas, Taylor, and Sjoblom voted yes. The motion carried.

PUBLIC COMMENTS:

John Grubb, 6966 S. 475 E., discussed Resolution 14-07 being incorporated into the agreement. He has put together a draft for Tom. He said the minutes from the last meeting discussed an unsigned agreement. He said that is not the original agreement. He is still working on a new agreement. He said there are approximately 40 members of the train club.

Tim Grubb, 6926 S. 475 E., said the Petersen family donated a couple of acres to Canyon Meadows Park in which a family barn was donated as well. He said at one time discussion took place regarding possibly restoring the barn. He said the family did agree to let the City do what they want with the barn. He said many residents use the barn for family photos but it is falling apart and needs some maintenance. He said the property donated is phase 4 of the park. He said that area is also a pretty passive use. He said the City's master plan shows a bowery right where the barn sits. He would like to see a bowery. He has had an engineer come out and look at it. He would like to know the possibility to convert the barn into a bowery. He suggested putting together a committee to help restore the barn into a bowery. He understands the City doesn't have funds to do this right now, but he would like to see it included in a master plan. He would suggest putting a new roof on it to stop deterioration. He estimated it costing \$10,000 to \$25,000. He said the size is 26' x 52'. He said this would add a little bit of country to the park. Allowing for picnic tables, family photos, etc. He is asking that this be part of the City's master plan.

REPORTS:

Mayor Long: She attended a Waste Management Meeting in Baltimore. She said there are a lot of finance groups looking to fund smaller countries for making sure trash removal is being paid. She had the opportunity to tour some very large landfills.

Council Member Sjoblom: She thanked those involved with Meet the Candidate Night.

Council Member Casas: He said the new trees have been planted at Central Park. He would like to know the comparisons for building permits. Tom said he will report on that in November.

City Manager: He reported that the City is trying to get a street striping quote but has only received one response. He said October 14th is the Fire Department 50th year anniversary. October 16th at 6:00 will be a Fire Prevention Night.

Planning Commission: Tim Grubb, representing the Planning Commission, reported that the Planning Commission will be meeting this Thursday to discuss the following: Amending Code Ordinances: 11.06 Impact Fees; 10.5P.2 & 3 Residential Patio (R-P), Permitted Uses and Conditional Uses, Adopting Code Ordinance, 10.5Q Visual Buffer Overlay Zone (V-B), Land Use Specifications: Public Works Standards, Conditional Use Permit: Application for twin homes located at approx. 7170 S. 1700 E. (Parcel 13-017-0013) approx. 0.6 acres, by applicant Jason Bickley. Discussion took place regarding the twin home being only 30 ft. from Interstate 84. It was stated it meets city code. Council Member Casas feels this is not safe for the location of the building. Discussion took place regarding the new soccer complex and the buffer yard from Trevor Schenk’s property. It was stated that no landscaping has taken place yet. They are currently working on the parking lot. Discussion took place regarding South Weber Drive access to the complex. It was stated there is a west turning lane going into the complex. Brandon said they have met UDOT’s requirements.

ADJOURNED: Council Member Sjoblom moved to adjourn the meeting at 7:03 p.m. and go into a CLOSED MEETING - as per UCA § Section 52-4-205(1)(D): to discuss the purchase, exchange or lease of real property, including any form of a water right or water share. Council Member Taylor seconded. Tom called for the vote. Council Members Casas, Taylor, and Sjoblom voted yes. The motion carried.

Mayor Long welcomed everyone back into the open meeting and asked if there was any further discussion.

Council Member Sjoblom moved to direct the City Staff to enter into an agreement to meet with the agent to purchase parcel 13-021-0054 for \$215,000. Council Member Taylor seconded. Tom called for the vote. Council Members Casas, Taylor, and Sjoblom voted yes. The motion carried.

ADJOURNED: Council Member Taylor moved to adjourn the City Council meeting at 7:38 p.m. Council Member Sjoblom seconded the motion. All were in favor.

APPROVED: _____ Date

Mayor: Tammy Long

Transcriber: Michelle Clark

Attest: _____
City Manager: Tom Smith

RESOLUTION 17-40

A RESOLUTION OF THE SOUTH WEBER CITY COUNCIL ADOPTING DEVELOPMENT, DESIGN, & CONSTRUCTION STANDARDS AND PUBLIC WORKS STANDARD DRAWINGS

WHEREAS, South Weber City has established Development, Design, & Construction Standards and Public Works Standard Drawings to define the general requirements for improvements to be built by a subdivider or contractor working with the public way; and

WHEREAS, on the 12th of October 2017 the South Weber City Planning Commission held a public hearing and has reviewed the Development, Design, & Construction Standards and Public Works Standard Drawings as submitted and recommended by the City Engineer, and has made a favorable recommendation of these standards; and

WHEREAS, the South Weber City Council has reviewed the new Development, Design, & Construction Standards and Public Works Standard Drawings and has found them to serve at the interests of the City;

NOW THEREFORE, BE IT RESOLVED, by the City Council of South Weber City, Utah, that the Development, Design, & Construction Standards and Public Works Standard Drawings, attached hereto, are hereby adopted and said Development, Design, & Construction Standards and Public Works Standard Drawings shall be enforceable in conjunction with the South Weber City Municipal Code.

PASSED AND ADOPTED by the City Council on this 24th day of October 2017.

TAMARA P. LONG, Mayor
South Weber City

ATTEST:

Mark McRae, City Recorder

Roll call vote is as follows:

Mr. Taylor	yes	no
Mr. Hyer	yes	no
Mrs. Sjoblom	yes	no
Mr. Casas	yes	no
Mr. Winsor	yes	no

MEMORANDUM

TO: South Weber City Mayor and Council

FROM: Brandon K. Jones, P.E.
South Weber City Engineer 

CC: Tom Smith – South Weber City Manager
Mark Larsen – South Weber City Public Works Director
Mark McRae – South Weber City Recorder

RE: **DEVELOPMENT, DESIGN, & CONSTRUCTION STANDARDS**
Summary of Changes

Date: October 18, 2017

The current version of the City Standards was adopted on August 11, 2009. While the majority of these City Standards will remain, there are several items in need of updating. In accordance with Utah Code Section 10-9a-103-29 (a) and Section 10-9a-502, these “specifications” constitute “land use regulations,” and need to be adopted as such. The recommended changes come as a result of industry standard changes, regulatory changes, field observations, and changes needed for increased longevity of the improvements that the City is responsible to maintain and replace over time.

These changes were presented, discussed and recommended for approval by the Planning Commission on October 12, 2017. A public hearing was also held at that meeting, but there were no comments from the public relative to the recommended changes. It would be very difficult to provide a comprehensive list of all changes and/or revisions; however, the following list contains the major and most notable changes:

1. Adoption of Divisions 01 through 34 of the Manual of Standard Specifications and Manual of Standard Plans (drawings), as published by Utah LTAP Center, Utah State University, Logan, Utah, current edition, with all published amendments; along with other Modifications and Additions as needed to match current practices or procedures. These Standards are frequently referred to as the APWA Specifications and Drawings.
2. As a result of the street condition assessment performed in 2015 and 2017 it has been observed that, in general, the City’s street pavement section and asphalt have not been performing to the design life expected. Therefore, we are recommending a change to the pavement section and the asphalt mix.
 - a. The change to the pavement section would go from 3” thick asphalt over 10” thick roadbase to a minimum of 4” thick asphalt over 12” thick roadbase. This

- pavement section is better suited to handle the actual traffic loading experience during the initial construction of homes, as well as the long-term loading.
- b. The change to the asphalt mix will reduce the percent of Recycle Asphalt Pavement (RAP) to a maximum of 15%, use PG 58-28 binder, require a minimum of 1% lime and require SP-1/2 (super pave ½" aggregate). This asphalt mix will extend the life and longevity of the asphalt itself.
 3. The sidewalk thickness has been changed to be 6" thick everywhere. Currently, the sidewalk is required to be 6" thick for the drive approach and the sidewalk through the driveway, but 4" thick everywhere else. The common practice (because driveway locations are not known until the home is being built) is to install the entire sidewalk at 4" thick and then tear out where the driveway goes and pour it back at 6" thick. In doing a cost evaluation of making this change, we determined that there was very little, if any, overall cost increase when comparing the two methods. In fact, if the driveway is large, it would actually cost more to pour 4" and then tear it out and put back 6" thick concrete. We also feel that making all sidewalks 6" thick will extend the longevity of the sidewalk; reducing long term cracking or settling, and the associated cost of maintaining sidewalks.
 4. The drawings now include a detail to add more clarity on the location of service lines to the lot.
 5. The adopted street cross sections for Old Forth Road were added as well as a street section for South Weber Drive that would allow for three lanes of traffic.
 6. The drawings added a detail for ADA compliance on sidewalk at driveway approaches.
 7. The drawings added a detail for asphalt patching requirements.
 8. The drawings added a detail for tracer wire for water lines. Even though the waterlines are ductile iron, there are still cases where they are difficult to locate.
 9. The drawings added a detail with a sizing chart for storm drain catch basins based on the size of pipe being connected.
 10. The drawings added details for a standard storm drain outlet control structure (for small and large detention basins) as well as an emergency overflow detail. This should help remove any questions about the design elements needed on these structures.
 11. The Planning Commission asked if the standard streetlight specified had a cutoff to help keep the light pointing down and not shining up into the night sky. In looking into it further, it appears that it does not, nor is it available in LED from Rocky Mountain Power (despite what we were previously told by RMP). Given this new information as well as previously mentioned concerns from Councilmember Casa, we feel that more research needs to be done on streetlights in general (including a cost/benefit analysis of for long-term maintenance). We would recommend adopting the standards as is for now, and then coming back and amending the streetlight standard once a determination of the best path forward is made.
 12. Examples of Low Impact Development (LID) were included. These are currently encouraged, but not required. These types of measures will be required in the near future by the EPA, and we felt that including them as an option would help to prepare for the coming regulation.

South Weber City Corporation

Development, Design, & Construction Standards



October 2017

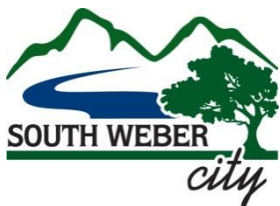

Prepared by
JONES & ASSOCIATES
Consulting Engineers



DEVELOPMENT, DESIGN, AND
CONSTRUCTION STANDARDS
for
SOUTH WEBER CITY

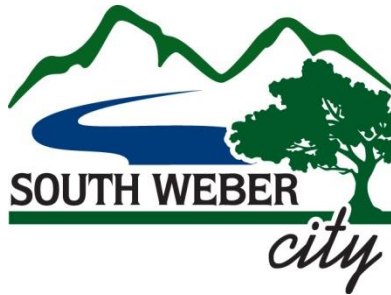

SUBMITTED & RECOMMENDED:

APPROVED:

Brandon K. Jones, P.E.
City Engineer

Date

Tamara Long
Mayor

Date

Tom Smith
City Administrator

Date

Barry Burton
City Planner

Date

Mark Larsen
Public Works Director

Date

Mark McRae
Attest, City Recorder

Date

TABLE OF CONTENTS

SECTION 1 GENERAL..... 1

 1.01 South Weber City Municipal Code Governs..... 1

 1.02 Conformance with Federal, State, and Local Laws 1

 1.03 Definitions 1

 1.04 Acronyms..... 2

 1.05 Modification Process..... 2

SECTION 2 DEVELOPMENT STANDARDS 4

 2.01 Approval Procedure 4

 2.02 Developer Responsibilities 4

 2.03 Subdivision Standards 5

SECTION 3 DESIGN STANDARDS..... 6

 3.01 Required Improvements 6

 3.02 Improvement Plans 6

 3.03 Sanitary Sewer Design..... 7

 3.04 Water Design..... 7

 3.05 Street/Road Design 7

 3.06 Storm Drain Design 8

 3.07 Low Impact Development 8

SECTION 4 CONSTRUCTION STANDARDS..... 9

 4.01 General Policies..... 9

 4.02 Pre-Construction Conference..... 12

 4.03 Construction..... 13

SECTION 5 TECHNICAL SPECIFICATIONS 16

 5.01 Technical Specifications for South Weber City 16

 5.02 Order of Precedence 16

SECTION 6 STANDARD DRAWINGS, PLANS, AND DETAILS..... 17

 6.01 Standard Drawings, Plans, and Details for South Weber City..... 17

 6.02 Order of Precedence 17

APPENDICES

 A STORM DRAIN AND DRAINAGE DESIGN STANDARDS

 B MODIFICATIONS AND ADDITIONS TO MANUAL OF STANDARD SPECIFICATIONS

 C SOUTH WEBER CITY PUBLIC WORKS STANDARD DRAWINGS

SECTION 1 GENERAL

1.01 South Weber City Municipal Code Governs

Nothing in this document shall be construed to be contrary to South Weber City Municipal Code. Should a conflict exist between this document and the Ordinances, the Code shall govern.

1.02 Conformance with Federal, State, and Local Laws

Nothing in this document shall relieve the Developer, Engineer, or Contractor from abiding by any and all Federal, State, and local laws.

1.03 Definitions

- A. Contractor – The individual, firm, co-partnership, or corporation, and his, their, or its heirs, executors, administrators, successors, and assigns, or the lawful agent of any such individual firm, partnership, covenantor, or corporation, or his, their, or its surety under the contract bond, constituting one of the principals to the contract and undertaking to perform the Work.
- B. Drawings – The City-approved construction drawings, the South Weber City Public Works Standard Drawings, and/or the Manual of Standard Drawings, as applicable.
- C. Developer – The person sponsoring construction of the improvements.
- D. Development – The subject subdivision, minor subdivision, or building.
- E. Improvements – See “Work.”
- F. Improvement Plans – See “Drawings.”
- G. Inspector – The authorized representative of the City or City Engineer assigned to make all necessary inspections of the Work performed or being performed, or of materials furnished or being furnished by the Contractor.
- H. Work – All types of work necessary to provide safe access and utility service to and within proposed subdivision or site, including, but not limited to, site grading, utility installation, and street construction. Work includes all labor, services, and documentation necessary to produce such construction; furnishing, installing, and incorporating all materials and equipment into such construction; and may include related services such as testing, start-up, and commissioning.¹
- I. See also the South Weber City Municipal Code. Where definition conflicts arise between City Ordinance and this document, the definitions in this document shall take precedence when in reference to this document.

¹ From EJCDC© C-700, Standard General Conditions of the Construction Contract.

1.04 Acronyms

- A. BMP – Best Management Practice
- B. CFP – Capital Facilities Plan
- C. DDW – Division of Drinking Water
- D. DWQ – Division of Water Quality
- E. DWRi – Division of Water Rights
- F. FEMA – Federal Emergency Management Agency
- G. HOA – Homeowners’ Association
- H. LID – Low Impact Development
- I. RCP – Reinforced Concrete Pipe
- J. SWC – South Weber City
- K. UDEQ – Utah Department of Environmental Quality
- L. UDOT – Utah Department of Transportation
- M. UPDES – Utah Pollutant Discharge Elimination System
- N. USACE – United States Army Corps of Engineers

1.05 Modification Process

- A. Whenever, in the opinion of the City Public Works Department, the City Engineer, or the Superintendent having jurisdiction, a literal enforcement of these regulations may work an undue hardship or a literal enforcement of the provisions may be unnecessary to meet the goals and standards of the City, the City may modify those standards in the following manner:
- B. Modifications may be granted when there are practical difficulties involving carrying out the provisions of the Public Works Standards and Technical Specifications, and a panel consisting of the City Planner, City Engineer, and the Public Works Director or his Representative determine that granting of a modification for an individual case will meet the goals and requirements of the City without unduly jeopardizing the public and the individual’s interest.
 - 1. The City shall first receive a written request for a modification to the standards from any interested party.
 - 2. Upon receipt of the request, the panel of three discussed above shall find that a special individual reason makes the strict letter of the standard impractical, and shall find the modification is in conformance with the intent and purpose of the standards and shall find that such modification does not in any way lessen the integrity of the standards.

3. When such findings of fact are made, the panel may grant such modification as it deems appropriate. The details of any action granted as modification by this panel shall be recorded and entered in the files of the City, with the specific reasons for the granting of said modification.

SECTION 2 DEVELOPMENT STANDARDS

2.01 Approval Procedure

See Title 11 – Subdivision Regulations of the South Weber City Municipal Code

2.02 Developer Responsibilities

- A. Required Improvements and Guarantees – see Title 11 of South Weber City Municipal Code.
- B. Permits and Approvals
 - 1. Developer is responsible for obtaining all necessary permits and approvals for the construction of the Improvements. Copies of all applications and approved permits shall be submitted to the City. Agencies/permits that may be required include, but are not limited to:
 - a. DDW Plan Approval (pre-construction)
 - b. DDW Operating Permit (post-construction)
 - c. UPDES NOI and NOT
 - d. DWRi Stream Alteration
 - e. DWRi Dam Safety
 - f. EPA 404 Wetlands
 - g. FEMA CLOMA and/or CLOMR
 - h. UDOT
 - i. Others as applicable
- C. Improvements
 - 1. The required improvements shall include all street improvements in front of all lots along all dedicated streets to a connection with existing improvements of the same kind or to the boundary or the subdivision nearest existing improvements. Design must provide for future extension to adjacent development and to be compatible with the contour of the ground for proper drainage. All water lines, sewer lines, and any other buried conduit shall be installed to the boundary lines of the subdivision. See Chapter 11.04 for more information.
 - 2. Upsizing based on CFPs – The Developer will be required to construct/install infrastructure sized in accordance with the City’s currently adopted CFPs. The City will be responsible for paying difference in cost between the master planned infrastructure size and the minimum infrastructure size required for the development.
 - 3. Seal Coat – See Municipal Code.
 - 4. Street Lighting – See Municipal Code.

5. Street Signage – See Municipal Code.
6. Survey of Existing Improvements – Developer shall reimburse City for City Engineer’s time spent surveying in locations of new improvements.

2.03 Subdivision Standards

- A. The general standards for subdivision layout and development are found in Title 11 – Subdivision Regulations.
- B. See also Section 3 – Design Standards and Section 4 – Construction Standards of this document.

SECTION 3 DESIGN STANDARDS

3.01 Required Improvements

- A. See Chapter 11.04 for information on the required improvements.
- B. See also Section 5 – Technical Specifications and Section 6 – Standard Drawings, Plans, and Details of this document for additional information.

3.02 Improvement Plans

- A. Complete and detailed, and signed and sealed (in accordance with Utah Code 58-22-602) construction plans and drawings of improvements shall be submitted to the City for the review by the City Engineer prior to receiving final plat approval and prior to commencing construction. Per Chapter 11.04, no construction shall begin until plans have been checked and approved by the City Engineer, and final approval is granted by the City Council.
- B. The following instructions are for the purpose of standardizing the preparation of drawings to obtain uniformity in appearance, clarity, size, and style. The plans and designs shall meet the standards defined in the specifications and drawings hereinafter outlined. The minimum information required on the drawings for improvements is as follows:
 - 1. All drawings and/or prints shall be clear and legible and conform to industry standard engineering and drafting practices.
 - 2. Drawings shall be legible and to a common scale when printed on 11"x17" paper.
 - 3. Both plan view and centerline profile must be shown. On subdivisions along steep cross slopes, profiles for each side of the street may be required to be shown.
 - 4. Plan and profiles shall indicate design and/or existing grades a minimum of 200 feet beyond the limits of the proposed project.
 - 5. All wet utilities (water, sewer, storm drain, irrigation) shall be shown in plan and profiles views.
- C. Each set of plans shall be accompanied by a separate sheet of details for special structures which are to be constructed and are not covered by the City Standards. All structures shall be designed in accordance with the minimum South Weber City Standards and approved by the City Engineer.
- D. Separate drawings of elements of the South Weber City Standards shall not be required to be redrawn and submitted with the construction drawings unless specific deviations from the standards are requested for approval; however, the construction drawings shall refer to the specific items of the Standards that are to be incorporated into the Work.
- E. The plan and profile construction plans shall be submitted in portable document format ("pdf"). Upon approval, the developer's engineer shall provide the City Engineer with electronic files of the final plat and improvement plans in AutoCAD or other City Engineer approved format. A hard copy of the approved construction plans bearing the signature of

the City Engineer shall be kept available at the construction site. Prior to final acceptance by the City, the developer, developer's representative, contractor, or project engineer shall submit to the City Engineer a set of "as built" drawings for permanent City file record.

3.03 Sanitary Sewer Design

- A. All design shall be in accordance with Utah Administrative Code R317.
- B. All terminating sewer mains shall end with a city standard manhole.
- C. Service lateral connection shall not be allowed in sewer manholes.
- D. All sewer shall be gravity unless otherwise approved by the City.
- E. Collection lines shall be located in public rights-of-way or private road rights-of-way. Collection lines shall not be located on private property (easements) without the express written permission from the City. If such case is granted, easement shall be a minimum of 20' and shall be dedicated to the City of South Weber.

3.04 Water Design

- A. All design shall be in accordance with Utah Administrative Code R309.
- B. Valves are required on all branches of tees and crosses. On unbroken lengths of water line, the maximum valve spacing is 1000-ft.
- C. At dead end lines, including temporary dead ends, provide fire hydrant at termination point.
- D. All fire lines shall meet public works standards, but shall remain privately owned and maintained.
- E. Fire hydrants are to be installed in locations as required by the fire code and approved by the Fire Marshal and City Engineer, with a minimum spacing of 500-ft.

3.05 Street/Road Design

- A. Design
 - 1. Streets shall be designed in accordance with these Standards, standard engineering practices, and AASHTO and MUTCD guidelines.
 - 2. No changes of grade in excess of 1.5% shall be permitted without a vertical curve.
 - 3. Sight triangles shall be shown at the request of the City Engineer.
 - 4. Cul-de-Sacs
 - a. Length of cul-de-sac shall not exceed 500-ft as shown in the Standard Drawings.
 - 5. Temporary Turnarounds
 - a. When turnaround cannot be constructed outside of subdivision, it shall be located on a portion of the subdivision lots (as needed) with the developer placing in escrow

an amount of money sufficient to complete the street improvements to the subdivision boundary. These funds will be used at such time the street is extended.

- b. Drainage onto adjacent property must be by written approval (easement) of adjacent property owner.
- c. The lot on which the turnaround is constructed shall be restricted as follows:
 - (i) Platted as an "R" (restricted) lot.
 - (ii) This lot cannot be sold or building permits issued until the road is extended beyond the subdivision boundary, complete with curb, gutter, and sidewalk.

6. Landscaping

- a. When landscaping is required to be designed/installed, refer to the Standard Drawings.

7. UDOT

- a. Roadway intersections with UDOT controlled streets shall be in accordance with UDOT standards. A copy of the approved UDOT Access Permit shall be submitted to the City.

3.06 Storm Drain Design

- A. See Appendix A for Storm Drain and Drainage Design Standards.

3.07 Low Impact Development

- A. [SECTION RESERVED]

SECTION 4 CONSTRUCTION STANDARDS

4.01 General Policies

A. General Conditions

1. Permit/License: When the work is in progress, Contractor shall have at the work site a copy of the permit and his contractor's license number.
2. Private access: Temporary all weather roadways, driveways, walks, and right-of-ways for vehicles and pedestrians shall be constructed and continuously maintained where required.
3. Street excavation in winter: Excavation of City streets during the winter months (herein defined as November 15 to April 1) will be allowed only if the work is a new service connection, required maintenance or emergency, or otherwise approved by the Public Works Department. Permanent patching of City streets excavated in the winter may be delayed until April 1 with the following provisions: Within five working days from the completion of the excavation, the permittee provides/maintains a 1-1/2" thick temporary winter asphalt surface until such time as the permanent asphalt surface is installed; the permittee shall provide/maintain a temporary untreated base course surface until such time as the temporary winter asphalt surface is installed. These provisions apply regardless of whether the permittee or City crews are performing the permanent resurfacing.
4. Existing utilities: The contractor shall use extreme caution to avoid a conflict, contact, or damage to existing utilities, such as power lines, sewer lines, storm drains, street lights, telephone lines, cable television lines, water lines, gas lines, poles, or other appurtenances during the course of construction of this project. Any such conflict, contact, or damage shall be immediately communicated to said utility company and the Public Works Department. All projects shall be "Blue Staked" prior to construction.
5. Preconstruction pictures of existing public way improvements: The permittee may secure pictures of the conditions of the existing public way improvements such as curbing, sidewalk, landscaping, asphalt surfaces, etc. In the event that public way improvements are damaged and no pictures are taken, the Public Works Department will assume the correction of the damage is the responsibility of the permittee.

B. Licensing

1. Contractor (including all sub-contractors) must be licensed with the State of Utah: It is the policy of South Weber City that contractors desiring to perform work in the City's public way shall be properly licensed in the State of Utah. The acceptable licenses include:

TYPE OF WORK	LICENSE
Any type of concrete work	E100 B100 R100 S260
Paving	E100 S400
Landscaping	E100 S330
Buried gas, telephone, water, irrigation and power lines	E100 S390 S410
Sanitary sewer and storm drains	E100 S210 S216 S390
Asphalt Patching	E100 S400
Trenching	E100 S310
Highway Sign Installation	E100 S440
Manhole Covers	E100 S210 S390 S410
Paint Striping Highways	E100 S300

2. Exceptions: A license shall not be required by the City when the permittee is a public utility company. (Subcontractors for utility companies shall have a valid contractor’s license.)

C. Permits

1. Developer/Contractor is responsible for obtaining all necessary permits for the construction of the Improvements prior to commencement of said Improvements. Agencies/permits required may include, but are not limited to:
2. Encroachment (City)
 - a. South Weber City's Department of Public Works issues permits to control any excavation and construction operations in the public right-of-way. All contractors, sub-contractors, and utility companies proposing to construct, repair, or replace any facility within the public right-of-way shall contact the South Weber City Building Department and complete all permit requirements prior to commencing proposed work.
 - b. Work by utility companies and their contractors in constructing facilities in new subdivision streets shall be required to post a bond with the City and will be subject to City inspection and compliance with all requirements.

- c. Emergency Work
 - (i) Maintenance of pipelines or facilities in the public way may proceed without a permit when emergency circumstances demand the work be done immediately provided a permit could not reasonably and practicably have been obtained beforehand.
 - (ii) In the event that emergency work is commenced on or within any public way of the City, the Public Works Department shall be notified within one-half hour when the work commences or as soon as possible from the time the work is commenced. Contact shall be made to the City's "on call" personnel. If emergency work is commenced during off business hours, the Public Works Department will be notified within one (1) hour of the start of work on the first regular business day of which City offices are open after such work commences, and, at the discretion of the Public Works Department, a permit may be issued which shall be retroactive to the date when the work was begun. Before commencing the emergency work, all necessary safety precautions for the protection of the public and the direction and control of traffic shall be taken. None of the provisions of these regulations are waived for emergency situations except for the prior permit requirement.
 - d. Enforcement: Violators of these regulations of working within the Public Way shall be subject to the provisions of the applicable South Weber City Municipal Code.
3. USACE/DWRi Stream Alteration – Stream Alteration
 4. UPDES
 5. Dam Safety (DWRi)
 6. UDOT
 7. Davis County Surveyor's Monument
 8. Excavation Operations
 - a. Blue Stakes: Before commencing excavation operations, the permittee shall call "Blue Stakes" at 1-800-662-4111 or 811.
 9. Traffic control devices: Traffic control devices such as construction signs, barricades, and cones must be in place before excavation begins.
 10. Protection of paved surfaces outside of excavation area: In order to avoid unnecessary damage to paved surfaces, backhoes, outriggers, tracked equipment, or any other construction equipment that may prove damaging to asphalt shall use rubber cleats or paving pads when operating on or crossing said surfaces.
 11. Open trench limits: Open trenches will be limited to one block at a time or 660 feet, whichever is less.

12. In the event of a planned road closure, Contractor shall notify the City, Fire Department, emergency services dispatch, US Postal Service, and Davis School District a minimum of 24 hours prior to the closure. In the case of an emergency, the above listed agencies will soon be notified at the soonest possible time.
13. Environmental Controls
 - a. Dust and debris: The permittee or contractor shall keep dust and debris controlled at the work site at all times. If necessary, a container shall be provided for debris and dusty areas shall be wet down. The permittee or contractor shall be responsible for the cleanup of mud or debris from public roads deposited by vehicles or construction equipment exiting the work site. The City Engineer reserves the right to shut down the work or issue a citation if dust is not controlled.
 - b. Noise: The permittee or contractor shall keep neighborhood free of noise nuisance in accordance with the Noise Ordinance.
14. Cleanup: The permittee or contractor shall remove all equipment, material, barricades, and similar items from the right-of-way. Areas used for storage of excavated material will be smoothed and returned to their original contour. Vacuum sweeping or hand sweeping shall be required when the Building Department determines cleaning equipment is ineffective.
15. Storm Water: All Contractors working within the boundaries of South Weber City shall conform to all requirements and regulations as outlined by the South Weber City Storm Water Management Plan. Copies of the plan are available in the South Weber City Offices.

4.02 Pre-Construction Conference

- A. The pre-construction conference shall not be held until the City Engineer has approved and signed the construction plans.
- B. A preconstruction conference shall be held before any excavation or other work is begun in the subdivision or Project. The meeting will include:
 1. City Engineer
 2. Developer or Project Manager
 3. Subdivision or Project Engineer
 4. All contractors and subcontractors involved with installing the subdivision or project improvements
 5. Representatives of affected South Weber City Departments
 6. Representatives of local utility companies as may be required by South Weber City.
- C. Items pertaining to the construction and inspection of the subdivision or Project improvements will be discussed.

4.03 Construction

A. Specifications

1. Contractor shall be responsible for constructing all improvements in accordance with the Technical Specifications, per Section 5 of this document.
2. Deviations from such shall be reviewed and authorized by the City Engineer on a case-by-case basis.

B. Plans and Details

1. Contractor shall be responsible for constructing all improvements in accordance with the Drawings, Plans, and Details, per Section 6 of this document.
2. Deviations from such shall be reviewed and authorized by the City Engineer on a case-by-case basis.

C. Sequence/Timing

1. All underground utility work shall be completed prior to placement and compaction of the roadway base course. Utilities, including service lines, not installed prior to roadway construction shall be bored as approved by the Public Works Director.
2. All concrete collars shall be installed within fourteen (14) days of asphalt placement.

D. Inspection

1. All construction work involving the installation of improvements in the subdivision or project shall be subject to inspection by the City. It shall be the responsibility of the person responsible for construction to insure that inspections take place where and when required. Certain types of construction shall have continuous inspection, while others may have only periodic inspections.

E. Requests for Inspections

1. Requests for inspections shall be made to the Public Works Department by the person responsible for the construction.
2. Requests for inspection on work requiring continuous inspection shall be made three (3) working days prior to the commencing of the work.
3. Notice shall also be given one (1) day in advance of the starting of work requiring periodic inspection, unless specific approval is given otherwise by the City Engineer, or his duly authorized representatives.

F. Continuous Inspection

1. May be required on (but not limited to) the following types of work:
 - a. Laying of street surfacing
 - b. Placing of concrete for curb and gutter, sidewalks, and other structures

- c. Laying of sewer pipe, irrigation pipe, drainage pipe, water mains, water service laterals and testing.
 2. On construction requiring continuous inspection, no work shall be done except in the presence or by permission of the City Engineer or authorized city representative.
- G. Periodic inspections
 1. Shall be required on (but not limited to) the following types of work:
 - a. Street grading and gravel base
 - b. Excavations for curb and gutter and sidewalks
 - c. Excavations for structures
 - d. Trenches for laying pipe
 - e. Forms for curb and gutter, sidewalks and structures
- H. Substantial and Final Completion Inspections
 1. A substantial completion inspection shall be requested by the Contractor and made by the City Engineer or authorized representative after all construction work is completed. Any faulty or defective work shall be corrected by the persons responsible for the work within a period of thirty (30) days of the date of the City Engineer's or authorized representative's Punchlist defining the faulty or defective work.
 2. A final completion inspection shall be requested by the Contractor and made by the City Engineer or authorized representative after all faulty and defective work has been corrected.
- I. Testing
 1. Contractor shall be responsible for all testing in accordance with the Technical Specifications per Section 5 of this document.
 2. Testing shall be performed by a licensed and qualified testing firm. Contractor shall submit qualifications to City for approval of firm prior to beginning Work.
 3. Testing reports shall be submitted to City weekly for review. Areas with failed tests shall be corrected and retested.
 4. Failure to submit testing reports to the City shall be cause for work stoppage or rejection by City.
- J. Safety
 1. Contractor is solely responsible for jobsite safety.
 2. Contractor shall comply with all local, state, and federal rules and regulations regarding jobsite safety.

3. City and/or its authorized representatives shall have the authority to shut down a job when unsafe working conditions are found.

SECTION 5 TECHNICAL SPECIFICATIONS

5.01 Technical Specifications for South Weber City

- A. Adoption of Divisions 01 through 34 of the Manual of Standard Specifications, as published by Utah LTAP Center, Utah State University, Logan, Utah, current edition, with all published amendments.
- B. Modifications and Additions to Manual of Standard Specifications (see Appendix B)

5.02 Order of Precedence

- A. Approved project-specific specifications (when applicable)
- B. Modifications and Additions to Manual of Standard Specifications
- C. Manual of Standard Specifications, current edition, with all published amendments

SECTION 6 STANDARD DRAWINGS, PLANS, AND DETAILS

6.01 Standard Drawings, Plans, and Details for South Weber City

- A. South Weber City Public Works Standard Drawings, current edition (See Appendix C)
- B. Adoption of Manual of Standard Plans, published by Utah LTAP Center, Utah State University, Logan, Utah, current edition, with all published amendments.

6.02 Order of Precedence

- A. Approved project-specific drawings and details (when applicable)
- B. South Weber City Public Works Standard Drawings, current edition
- C. Manual of Standard Plans, current edition, with all published amendments, when not covered by one of the aforementioned items

APPENDIX A – STORM DRAIN AND DRAINAGE DESIGN STANDARDS

APPENDIX A

STORM DRAIN AND DRAINAGE DESIGN STANDARDS

A1. General Provisions

- A. Pleasant View faces unique storm water challenges because the City is surrounded on two sides by mountains and has the potential to receive a large amount of runoff in a short time. Pleasant View has tremendous opportunities for growth in residential, commercial, and industrial areas thus increasing the amount of impervious surfaces leading to increased runoff.
- B. This document represents the design and construction standards for private and public design and construction as it relates to storm drainage within the City. All efforts have been made for this policy to conform to the requirements of the Clean Water Act, Phase II; and the Storm Water Management Plan of the City.
- C. The following information is organized in such a way to follow the natural flow of storm water – from the initial rainfall hydrology (A2), to conveyance of the rain water (A3) to a basin (A4), then discharge to a natural outlet location (A5).

A2. Rainfall Hydrology

- A. All storm drain systems shall be designed to carry the 100-year storm, unless otherwise stated.
- B. Storm Specifications
 - 1. Local storm drain piping shall be designed for the 10-year storm, where the road or other above ground conveyance will carry the difference to the 100-year storm.
 - 2. All basins regardless of local or regional, or retention or detention, shall be designed to accommodate a 100-year storm event, including all piping into the basin.
 - 3. The storm duration used for the sizing of basins shall be based upon the worst case scenario and not the time of concentration.
 - 4. Volume in pipes, ditches, or roadside swales shall not be considered in the volume calculation for detention and retention basins.
- C. Rainfall Intensity – When using the Rational Method, use the rainfall intensity table included as Exhibit 1 to this document.
- D. Calculation Basis – For developments less than 20 acres, the Rational Method may be used. For developments larger than 20 acres, a City Engineer-approved computer model shall be used.
- E. Rainfall Pattern and Depth – For the use of computer models, the following rainfall pattern shall be used. This pattern is based on the Farmer-Fletcher Distribution. This pattern is for a

1-inch unit storm and must be multiplied by rainfall depth for storms of other magnitudes, as provided in Exhibit 2.

Farmer-Fletcher Distribution

Unit Storm

Time (Min.)	Depth (inches)	Time (Min.)	Depth (inches)	Time (Min.)	Depth (inches)	Time (Min.)	Depth (inches)	Time (Min.)	Depth (inches)	Time (Min.)	Depth (inches)
1	0	11	0.004	21	0.033	31	0.052	41	0.012	51	0.005
2	0	12	0.005	22	0.034	32	0.045	42	0.011	52	0.005
3	0.002	13	0.008	23	0.035	33	0.04	43	0.01	53	0.004
4	0.002	14	0.009	24	0.038	34	0.035	44	0.009	54	0.004
5	0.002	15	0.009	25	0.039	35	0.03	45	0.009	55	0.004
6	0.002	16	0.013	26	0.045	36	0.022	46	0.008	56	0.003
7	0.002	17	0.017	27	0.052	37	0.02	47	0.006	57	0.003
8	0.002	18	0.02	28	0.054	38	0.018	48	0.006	58	0.002
9	0.003	19	0.024	29	0.054	39	0.016	49	0.005	59	0.002
10	0.003	20	0.029	30	0.054	40	0.014	50	0.005	60	0.001

A3. Storm Drain System

A. Independent System

1. Storm waters shall not be conveyed in irrigation ditches.
2. Irrigation waters shall not be conveyed in storm drain systems.

B. Piping – Storm drain lines shall be reinforced concrete pipe (RCP), of appropriate class. Minimum size for storm sewer mains shall be 15-inch diameter. Pipe specifications are included in the Section 5 of the Development, Design, and Construction Standards. Where determined by the City Engineer and/or the Storm Drain Capital Facilities Plan, larger drain lines shall be installed to accommodate future development. The cost to provide adequate storm drainage to a development shall be paid for by the Developer. Upsizing will be coordinated at the time of development. The cost of upsizing will be the responsibility of the City.

C. Access – Storm drain lines shall have cleanout boxes, inlets, or manholes installed at all changes in grade or alignment, with a maximum distance of 400 feet between accesses. Structures shall be installed in accordance with the standard specifications and standard drawings.

D. Sump Drains are not allowed except as approved by the City Engineer on a case-by-case basis. Proper permitting is required.

A4. Detention and Retention Basins**A. Definitions**

1. Detention Basin – An open water storage pond designed to store a volume of water that reduces the post-development peak runoff of a storm to the pre-development runoff rate or other rate as defined by the governing body. This is accomplished by the use of an outlet control which controls the rate of flow out of the pond into the receiving storm drain or water body. The basin is intended to drain the storm water within a period of time to make the volume available for the next storm event.
2. Retention Basin - An open water storage pond designed to store the runoff volume of a storm. The basin is intended to dispose of water through infiltration and evaporation within a period of time to make the volume available for the next storm event.

B. Storm drainage basins are required for all development; however, developments less than one (1) acre are not required to have detention except when determined by the City Engineer.

C. Location – Detention basins shall be located with convenient access for maintenance and repair by maintenance personnel. This generally means that the basin property has frontage along a public roadway.

D. Parking lots – Storage of water shall not be allowed in parking lots.

E. Underground Storage – Underground storage will be considered for private basins only.

F. All detention basin designs and calculations shall be reviewed by the City Engineer for approval.

G. Maintenance and Ownership

1. Private Basins – When approved, private detention basins shall be owned and maintained by the property owner.
2. Local Public Basins – Local detention basins shall be constructed by the developer. Following acceptance of the construction, the ownership, operation, and maintenance shall be conveyed to the City.
3. Regional Detention Basins – Regional basins shall be owned and maintained by the City, constructed according to the criteria herein, and approved of the City Engineer. Actual ownership and responsibility shall be specifically defined in the Owner’s Dedication Certificates, Development Agreements, or by Deed.

H. Basin Easement and Access

1. Public Basins – The developer shall provide the City permanent access to any public basin.
2. Private Basin – The City shall be provided an easement for emergency access, operation, and/or repair for a private basin.

3. Access – Each basin shall be constructed with sufficient drivable access, outside of the basin, to any structure from a city street.
- I. Detention and Retention Basin Elements
 1. Side slopes – Side slopes shall not be steeper than 4:1 (horizontal to vertical).
 2. Bottom Slope – The basin floor shall be designed so as to prevent the permanent ponding of water. The slope of the floor of the basin shall not be less than 1% to provide drainage of water to the outlet grate and prevent prolonged wet, soggy, or unstable soil conditions. The preferred minimum slope is 2%.
 3. Freeboard – At least one (1) foot of freeboard is required (berm above the high water mark).
 4. Spillways
 - a. The spillway shall be designed to carry the 200-year storm flow minus the 100-year storm flow which is handled by the outlet control structure.
 - b. Spillways shall introduce flows back into the pipe or stream downstream of the outlet control.
 - c. Spillways shall include a maintained swale and drainage easement to a safe location.
 - d. The spillway shall be designed to prevent erosion.
 - e. All spillways shall be designed to protect adjacent embankments, nearby structures, and surrounding properties.
 5. Ground Covers – The surface area of the basin shall be sodded. A minimum of 4-inches of top soil must be installed prior to sod placement. The basin shall be provided with an automated sprinkler system approved by the City Engineer.
 6. Embankment (Fill) Construction – If a raised embankment is constructed for a basin (constructed with granular materials), it shall be provided with a minimum of 6-inches of clay cover on the inside of the berm to prevent water passage through the soil.
 7. Excavation (Cut) Construction – If the basin is constructed primarily by excavation, then it may be necessary to provide an impermeable liner and land drain system when constructed in the proximity of basements or other below grade structures as determined by a geotechnical evaluation.
 8. Multi-Use Basins – Basins may be designed as multi-use facilities when appropriate precautions are incorporated into the design. If amenities such as pavilions, playground equipment, volleyball courts, etc. are to be constructed within the water detention area of a basin, they shall be designed appropriately. Structures shall be designed for saturated soil conditions and bearing capacities are to be reduced accordingly. Restrooms shall not be located in areas of inundation. Inlet and outlet structures should

be located as far as possible from all facilities. No wood chips or floatable objects may be used in the area that will be inundated.

J. Detention Basins

1. Percolation – No reduction due to percolation for detention basins volumes shall be permitted.
2. Outlet Control – Private detention basins may have a calculated fixed orifice plate mounted on the outlet of the basin. Public detention basins shall have movable, screw-type head gates set at the calculated opening height with a stop block required to carry the maximum allowable discharge.
3. Low Flow Piping – The inlet and outlet structures may be located in different areas of the basin, requiring a buried pipe to convey any base flows that enter and exit the basin. (Cross gutters and surface flows are prohibited.)

K. Retention Basins

1. Retention basins must be specifically approved by the City Engineer.
2. Retention basins shall not be permitted within zones 1, 2, or 3 of any Drinking Water Source Protection Zone of any drinking water source.
3. An approved oil/sediment separator shall be installed upstream of retention basin.
4. Volume shall be based upon the 100-year, 3 hour storm. See Exhibits 1 and 2 for rainfall data.
5. Retention Basin Criteria – Retention basins may be permitted if the following conditions apply:
 - a. The distance between the nearest City storm drain and the boundary of the development is greater than:
 - i. 500 feet for subdivisions or 10 lots or less;
 - ii. 1,000 feet for subdivisions greater than 10 lots.
 - b. The basin is not located within a Hazardous Area (such as a steep slope) or some other sensitive area (such as a Drinking Water Source Protection Zone).
 - c. Recommendation by the City Engineer.
6. Percolation Rate for Retention Basins
 - a. A percolation test shall be performed by a licensed tester. The percolation test shall be performed at the elevation of the proposed grade of the bottom of the retention basin.
 - b. Due to degradation of soils ability to percolate over time, only 80% of the percolation rate shall be used in the calculations for the retention basins.

7. Retention basins shall be designed to completely drain within 48 hours of the primary storm event.

A5. Discharge

A. Allowable Discharge Design

1. Calculations shall be based on the 100-year storm event.
2. Calculations shall be based on the total acreage of the development draining to the basin.
3. Pass-through of offsite drainage through the development will be allowed.
4. Discharge shall not exceed pre-development runoff with pre-development meaning the condition of the land prior to settlement.
5. Alternatively, a standard discharge rate of 0.1 cubic feet per second per total acre may be used.
6. Controlled discharge will be established as described in A4.H.5 of this document.

B. Water Quality

1. Long-term Best Management Practices (BMPs) shall be used to maintain, to the maximum extent practical, the quality of the water to the pre-developed condition.
2. Construction BMPs shall be implemented per the City's Storm Water Management Plan.

- C. Discharge to Irrigation Ditches – No discharge shall be permitted to irrigation ditches and canals unless express written permission is obtained from the responsible ditch company or ditch owners.

EXHIBIT 1 – NOAA POINT PRECIPITATION FREQUENCY ESTIMATES - INTENSITY



NOAA Atlas 14, Volume 1, Version 5
Location name: Ogden, Utah, USA*
Latitude: 41.1331°, Longitude: -111.9381°
Elevation: 4511.67 ft**



* source: ESRI Maps
 ** source: USGS

POINT PRECIPITATION FREQUENCY ESTIMATES

Sanja Perica, Sarah Dietz, Sarah Heim, Lillian Hiner, Kazungu Maitaria, Deborah Martin, Sandra Pavlovic, Ishani Roy, Carl Tryppaluk, Dale Unruh, Fenglin Yan, Michael Yekta, Tan Zhao, Geoffrey Bonnin, Daniel Brewer, Li-Chuan Chen, Tye Parzybok, John Yarchoan

NOAA, National Weather Service, Silver Spring, Maryland

[PF_tabular](#) | [PF_graphical](#) | [Maps_&_aerials](#)

PF tabular

PDS-based point precipitation frequency estimates with 90% confidence intervals (in inches/hour)¹										
Duration	Average recurrence interval (years)									
	1	2	5	10	25	50	100	200	500	1000
5-min	1.73 (1.50-2.02)	2.17 (1.90-2.54)	2.95 (2.56-3.46)	3.67 (3.16-4.31)	4.84 (4.06-5.71)	5.93 (4.82-7.08)	7.21 (5.68-8.70)	8.74 (6.62-10.8)	11.2 (8.04-14.2)	13.6 (9.24-17.6)
10-min	1.31 (1.13-1.54)	1.65 (1.45-1.94)	2.25 (1.94-2.63)	2.80 (2.40-3.28)	3.68 (3.08-4.35)	4.51 (3.67-5.38)	5.48 (4.31-6.62)	6.65 (5.04-8.19)	8.54 (6.11-10.8)	10.3 (7.03-13.4)
15-min	1.08 (0.936-1.27)	1.36 (1.19-1.60)	1.86 (1.61-2.18)	2.31 (1.98-2.71)	3.04 (2.55-3.60)	3.72 (3.03-4.45)	4.53 (3.56-5.47)	5.50 (4.16-6.77)	7.06 (5.05-8.96)	8.52 (5.81-11.1)
30-min	0.730 (0.632-0.854)	0.918 (0.802-1.08)	1.25 (1.08-1.46)	1.56 (1.33-1.82)	2.05 (1.72-2.42)	2.51 (2.04-3.00)	3.05 (2.40-3.68)	3.70 (2.80-4.56)	4.75 (3.40-6.03)	5.74 (3.91-7.46)
60-min	0.452 (0.391-0.529)	0.568 (0.496-0.668)	0.773 (0.670-0.906)	0.962 (0.826-1.13)	1.27 (1.06-1.50)	1.55 (1.26-1.85)	1.89 (1.49-2.28)	2.29 (1.74-2.82)	2.94 (2.11-3.73)	3.55 (2.42-4.62)
2-hr	0.294 (0.259-0.338)	0.367 (0.324-0.422)	0.474 (0.416-0.544)	0.575 (0.499-0.663)	0.742 (0.630-0.863)	0.896 (0.742-1.05)	1.08 (0.865-1.28)	1.30 (1.00-1.57)	1.65 (1.20-2.06)	1.97 (1.37-2.53)
3-hr	0.226 (0.203-0.256)	0.279 (0.250-0.317)	0.348 (0.310-0.395)	0.414 (0.365-0.470)	0.520 (0.450-0.595)	0.619 (0.524-0.716)	0.739 (0.610-0.867)	0.881 (0.705-1.05)	1.12 (0.848-1.39)	1.33 (0.971-1.70)
6-hr	0.152 (0.139-0.168)	0.186 (0.170-0.206)	0.224 (0.204-0.248)	0.259 (0.234-0.288)	0.312 (0.278-0.348)	0.356 (0.313-0.400)	0.409 (0.353-0.466)	0.469 (0.395-0.542)	0.586 (0.477-0.702)	0.692 (0.547-0.861)
12-hr	0.097 (0.089-0.107)	0.119 (0.108-0.131)	0.143 (0.130-0.158)	0.164 (0.148-0.181)	0.196 (0.175-0.218)	0.223 (0.196-0.250)	0.251 (0.218-0.285)	0.282 (0.239-0.325)	0.332 (0.273-0.391)	0.373 (0.299-0.448)
24-hr	0.060 (0.056-0.064)	0.073 (0.068-0.079)	0.087 (0.081-0.094)	0.099 (0.092-0.107)	0.115 (0.106-0.124)	0.127 (0.118-0.137)	0.140 (0.129-0.151)	0.153 (0.140-0.165)	0.170 (0.155-0.198)	0.189 (0.165-0.227)
2-day	0.036 (0.033-0.039)	0.044 (0.041-0.047)	0.052 (0.048-0.056)	0.059 (0.055-0.064)	0.068 (0.063-0.074)	0.075 (0.070-0.081)	0.083 (0.076-0.089)	0.090 (0.082-0.097)	0.099 (0.090-0.108)	0.107 (0.096-0.116)
3-day	0.026 (0.024-0.028)	0.032 (0.030-0.035)	0.038 (0.036-0.041)	0.044 (0.041-0.047)	0.051 (0.047-0.054)	0.056 (0.052-0.060)	0.062 (0.057-0.067)	0.067 (0.062-0.073)	0.075 (0.068-0.081)	0.081 (0.073-0.088)
4-day	0.022 (0.020-0.023)	0.026 (0.025-0.028)	0.032 (0.029-0.034)	0.036 (0.033-0.039)	0.042 (0.039-0.045)	0.046 (0.043-0.050)	0.051 (0.047-0.055)	0.056 (0.051-0.061)	0.063 (0.057-0.068)	0.068 (0.061-0.074)
7-day	0.015 (0.014-0.016)	0.018 (0.017-0.020)	0.022 (0.020-0.023)	0.025 (0.023-0.026)	0.029 (0.027-0.031)	0.032 (0.029-0.034)	0.035 (0.032-0.038)	0.038 (0.035-0.041)	0.042 (0.038-0.046)	0.045 (0.041-0.050)
10-day	0.012 (0.011-0.013)	0.015 (0.014-0.016)	0.017 (0.016-0.019)	0.020 (0.018-0.021)	0.022 (0.021-0.024)	0.025 (0.023-0.026)	0.027 (0.025-0.029)	0.029 (0.026-0.031)	0.031 (0.029-0.034)	0.033 (0.030-0.036)
20-day	0.008 (0.007-0.008)	0.010 (0.009-0.010)	0.011 (0.011-0.012)	0.013 (0.012-0.014)	0.014 (0.014-0.015)	0.016 (0.015-0.017)	0.017 (0.016-0.018)	0.018 (0.017-0.019)	0.019 (0.018-0.021)	0.020 (0.019-0.022)
30-day	0.006 (0.006-0.007)	0.008 (0.007-0.008)	0.009 (0.009-0.010)	0.010 (0.010-0.011)	0.012 (0.011-0.012)	0.013 (0.012-0.013)	0.014 (0.013-0.014)	0.014 (0.013-0.015)	0.015 (0.014-0.017)	0.016 (0.015-0.017)
45-day	0.005 (0.005-0.006)	0.007 (0.006-0.007)	0.008 (0.007-0.008)	0.009 (0.008-0.009)	0.010 (0.009-0.010)	0.011 (0.010-0.011)	0.011 (0.011-0.012)	0.012 (0.011-0.013)	0.013 (0.012-0.014)	0.014 (0.013-0.015)
60-day	0.005 (0.004-0.005)	0.006 (0.005-0.006)	0.007 (0.006-0.007)	0.008 (0.007-0.008)	0.009 (0.008-0.009)	0.009 (0.009-0.010)	0.010 (0.009-0.011)	0.011 (0.010-0.011)	0.011 (0.010-0.012)	0.012 (0.011-0.013)

¹ Precipitation frequency (PF) estimates in this table are based on frequency analysis of partial duration series (PDS). Numbers in parenthesis are PF estimates at lower and upper bounds of the 90% confidence interval. The probability that precipitation frequency estimates (for a given duration and average recurrence interval) will be greater than the upper bound (or less than the lower bound) is 5%. Estimates at upper bounds are not checked against probable maximum precipitation (PMP) estimates and may be higher than currently valid PMP values. Please refer to NOAA Atlas 14 document for more information.

[Back to Top](#)

PF graphical

PDS-based intensity-duration-frequency (IDF) curves

Latitude: 41.1331°, Longitude: -111.9381°

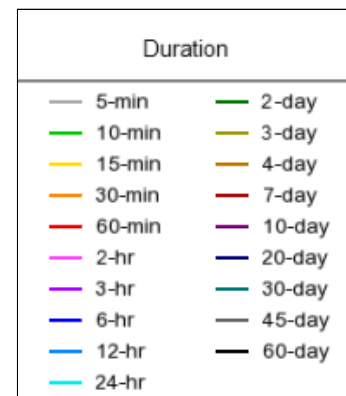
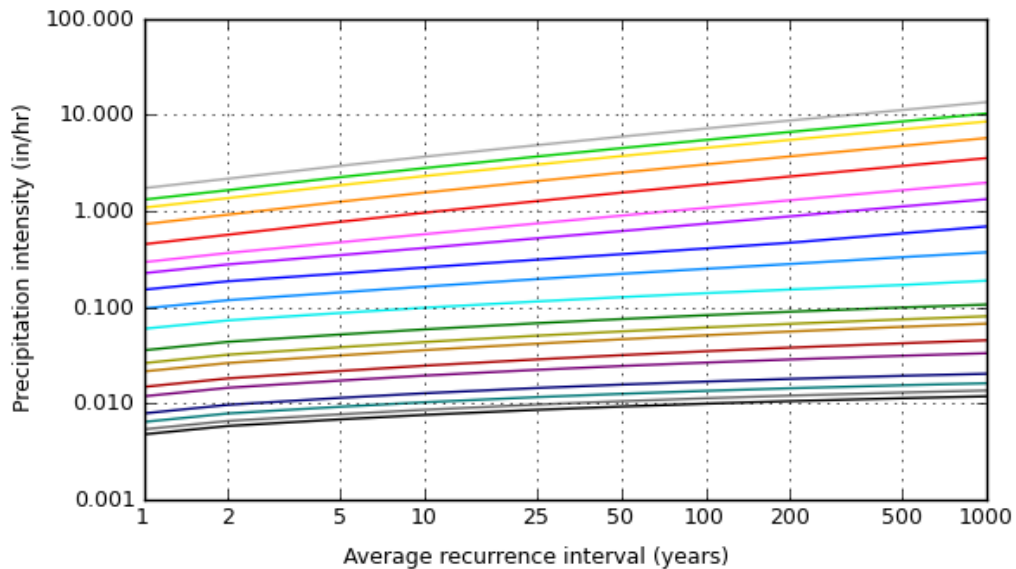
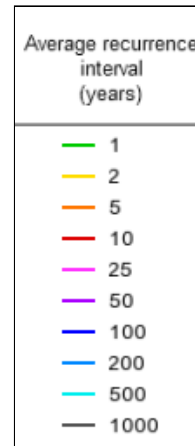
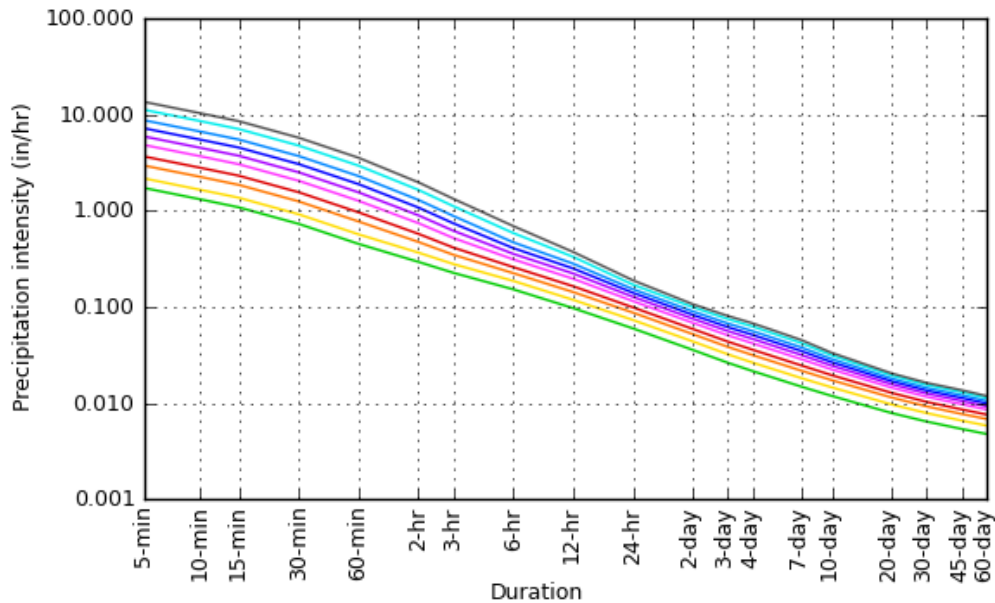

[Back to Top](#)

Maps & arials

Small scale terrain

EXHIBIT 2 – NOAA POINT PRECIPITATION FREQUENCY ESTIMATES - DEPTH



NOAA Atlas 14, Volume 1, Version 5
Location name: Ogden, Utah, USA*
Latitude: 41.1331°, Longitude: -111.9381°
Elevation: 4511.67 ft**



* source: ESRI Maps
 ** source: USGS

POINT PRECIPITATION FREQUENCY ESTIMATES

Sanja Perica, Sarah Dietz, Sarah Heim, Lillian Hiner, Kazungu Maitaria, Deborah Martin, Sandra Pavlovic, Ishani Roy, Carl Tryppaluk, Dale Unruh, Fenglin Yan, Michael Yekta, Tan Zhao, Geoffrey Bonnin, Daniel Brewer, Li-Chuan Chen, Tye Parzybok, John Yarchoan

NOAA, National Weather Service, Silver Spring, Maryland

[PF_tabular](#) | [PF_graphical](#) | [Maps_&_aerials](#)

PF tabular

PDS-based point precipitation frequency estimates with 90% confidence intervals (in inches)¹										
Duration	Average recurrence interval (years)									
	1	2	5	10	25	50	100	200	500	1000
5-min	0.144 (0.125-0.168)	0.181 (0.158-0.212)	0.246 (0.213-0.288)	0.306 (0.263-0.359)	0.403 (0.338-0.476)	0.494 (0.402-0.590)	0.601 (0.473-0.725)	0.728 (0.552-0.897)	0.935 (0.670-1.19)	1.13 (0.770-1.47)
10-min	0.219 (0.189-0.256)	0.275 (0.241-0.323)	0.375 (0.324-0.439)	0.466 (0.400-0.546)	0.614 (0.514-0.725)	0.751 (0.611-0.897)	0.914 (0.719-1.10)	1.11 (0.840-1.37)	1.42 (1.02-1.81)	1.72 (1.17-2.24)
15-min	0.271 (0.234-0.317)	0.341 (0.298-0.401)	0.464 (0.402-0.544)	0.578 (0.496-0.677)	0.760 (0.638-0.899)	0.931 (0.758-1.11)	1.13 (0.891-1.37)	1.37 (1.04-1.69)	1.77 (1.26-2.24)	2.13 (1.45-2.77)
30-min	0.365 (0.316-0.427)	0.459 (0.401-0.540)	0.625 (0.542-0.732)	0.778 (0.667-0.912)	1.02 (0.859-1.21)	1.25 (1.02-1.50)	1.53 (1.20-1.84)	1.85 (1.40-2.28)	2.38 (1.70-3.02)	2.87 (1.96-3.73)
60-min	0.452 (0.391-0.529)	0.568 (0.496-0.668)	0.773 (0.670-0.906)	0.962 (0.826-1.13)	1.27 (1.06-1.50)	1.55 (1.26-1.85)	1.89 (1.49-2.28)	2.29 (1.74-2.82)	2.94 (2.11-3.73)	3.55 (2.42-4.62)
2-hr	0.588 (0.518-0.675)	0.734 (0.649-0.845)	0.947 (0.832-1.09)	1.15 (0.998-1.33)	1.49 (1.26-1.73)	1.79 (1.48-2.10)	2.16 (1.73-2.57)	2.59 (2.00-3.15)	3.29 (2.40-4.12)	3.94 (2.74-5.06)
3-hr	0.679 (0.609-0.768)	0.838 (0.751-0.951)	1.05 (0.930-1.19)	1.24 (1.10-1.41)	1.56 (1.35-1.79)	1.86 (1.57-2.15)	2.22 (1.83-2.61)	2.65 (2.12-3.17)	3.35 (2.55-4.16)	3.99 (2.92-5.11)
6-hr	0.912 (0.835-1.00)	1.12 (1.02-1.23)	1.34 (1.22-1.49)	1.55 (1.40-1.72)	1.87 (1.66-2.09)	2.13 (1.87-2.40)	2.45 (2.11-2.79)	2.81 (2.36-3.25)	3.51 (2.86-4.20)	4.14 (3.28-5.16)
12-hr	1.17 (1.07-1.29)	1.43 (1.31-1.57)	1.72 (1.56-1.90)	1.98 (1.79-2.18)	2.36 (2.11-2.63)	2.68 (2.37-3.01)	3.03 (2.62-3.44)	3.40 (2.88-3.91)	4.00 (3.29-4.71)	4.49 (3.60-5.40)
24-hr	1.43 (1.33-1.54)	1.75 (1.63-1.90)	2.09 (1.95-2.26)	2.37 (2.21-2.56)	2.76 (2.55-2.97)	3.06 (2.82-3.29)	3.36 (3.09-3.62)	3.67 (3.36-3.96)	4.09 (3.71-4.76)	4.54 (3.97-5.46)
2-day	1.72 (1.60-1.85)	2.10 (1.95-2.27)	2.50 (2.33-2.70)	2.83 (2.63-3.05)	3.28 (3.04-3.53)	3.62 (3.34-3.91)	3.97 (3.64-4.29)	4.32 (3.94-4.67)	4.78 (4.32-5.19)	5.12 (4.61-5.59)
3-day	1.89 (1.76-2.04)	2.32 (2.16-2.50)	2.77 (2.58-2.98)	3.14 (2.92-3.38)	3.65 (3.38-3.92)	4.04 (3.73-4.35)	4.44 (4.08-4.79)	4.85 (4.43-5.24)	5.39 (4.88-5.85)	5.80 (5.22-6.32)
4-day	2.07 (1.92-2.22)	2.53 (2.36-2.72)	3.03 (2.83-3.25)	3.44 (3.21-3.70)	4.02 (3.73-4.31)	4.46 (4.13-4.79)	4.92 (4.52-5.29)	5.38 (4.92-5.81)	6.01 (5.45-6.51)	6.49 (5.83-7.06)
7-day	2.50 (2.33-2.68)	3.06 (2.86-3.29)	3.66 (3.41-3.92)	4.15 (3.87-4.45)	4.82 (4.48-5.17)	5.34 (4.94-5.73)	5.87 (5.40-6.30)	6.39 (5.86-6.90)	7.10 (6.45-7.71)	7.64 (6.89-8.34)
10-day	2.85 (2.66-3.05)	3.50 (3.26-3.75)	4.15 (3.88-4.44)	4.68 (4.37-5.00)	5.37 (5.00-5.74)	5.88 (5.46-6.29)	6.39 (5.91-6.85)	6.89 (6.35-7.40)	7.52 (6.89-8.12)	7.99 (7.28-8.66)
20-day	3.79 (3.53-4.05)	4.65 (4.34-4.99)	5.49 (5.13-5.88)	6.13 (5.73-6.57)	6.95 (6.49-7.43)	7.54 (7.03-8.06)	8.11 (7.54-8.68)	8.65 (8.02-9.27)	9.31 (8.60-10.0)	9.78 (9.00-10.5)
30-day	4.63 (4.33-4.95)	5.68 (5.31-6.07)	6.66 (6.23-7.12)	7.42 (6.93-7.92)	8.39 (7.82-8.96)	9.08 (8.45-9.70)	9.75 (9.04-10.4)	10.4 (9.60-11.1)	11.1 (10.3-12.0)	11.7 (10.7-12.6)
45-day	5.82 (5.43-6.24)	7.11 (6.63-7.64)	8.33 (7.78-8.94)	9.29 (8.66-9.95)	10.5 (9.79-11.2)	11.4 (10.6-12.2)	12.2 (11.4-13.1)	13.0 (12.1-14.0)	14.0 (12.9-15.1)	14.7 (13.5-15.9)
60-day	6.88 (6.42-7.35)	8.41 (7.85-9.02)	9.85 (9.21-10.5)	11.0 (10.2-11.7)	12.4 (11.5-13.2)	13.4 (12.5-14.3)	14.3 (13.3-15.4)	15.2 (14.1-16.3)	16.3 (15.1-17.6)	17.1 (15.7-18.4)

¹ Precipitation frequency (PF) estimates in this table are based on frequency analysis of partial duration series (PDS). Numbers in parenthesis are PF estimates at lower and upper bounds of the 90% confidence interval. The probability that precipitation frequency estimates (for a given duration and average recurrence interval) will be greater than the upper bound (or less than the lower bound) is 5%. Estimates at upper bounds are not checked against probable maximum precipitation (PMP) estimates and may be higher than currently valid PMP values. Please refer to NOAA Atlas 14 document for more information.

[Back to Top](#)

PF graphical

PDS-based depth-duration-frequency (DDF) curves

Latitude: 41.1331°, Longitude: -111.9381°

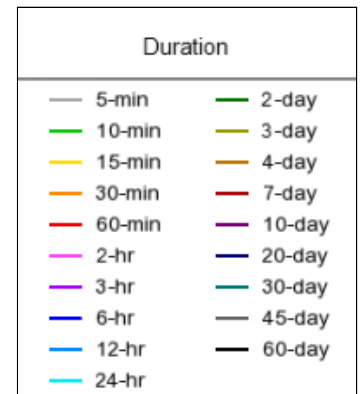
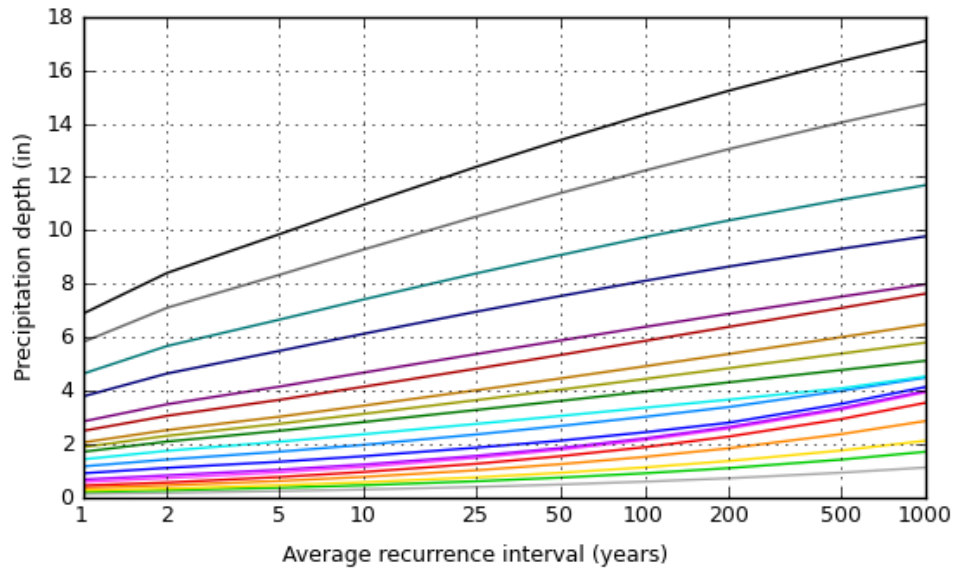
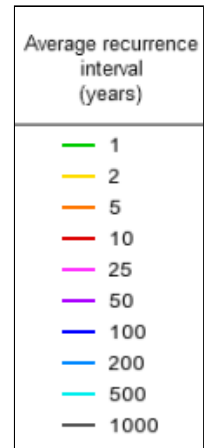
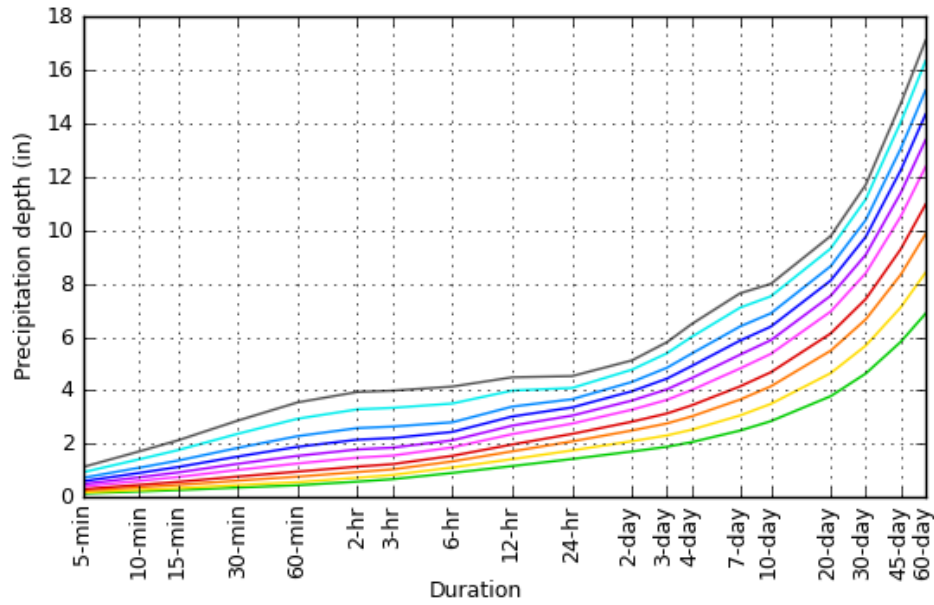

[Back to Top](#)

Maps & aeriels

Small scale terrain

APPENDIX B – MODIFICATIONS AND ADDITIONS TO MANUAL OF STANDARD SPECIFICATIONS

Modifications and Additions to the
2017 Manual of Standard Specifications

as published by:
Utah LTAP Center
Utah State University
Logan Utah
2017

TABLE OF CONTENTS

<u>Section</u>	<u>Page No.</u>
DIVISION 03 CONCRETE	
03 20 00 M CONCRETE REINFORCING (Modified)	1
03 30 04 M CONCRETE (Modified).....	2
03 30 10 M CONCRETE PLACEMENT (Modified).....	3
DIVISION 31 EARTHWORK	
31 23 16 M EXCAVATION (Modified).....	4
31 23 20 FILL	5
31 41 00 M SHORING (Modified).....	8
DIVISION 32 EXTERIOR IMPROVEMENTS	
32 01 06 STREET NAME SIGNS.....	10
32 01 13.64 M CHIP SEAL (Modified).....	11
32 01 05 M BITUMINOUS CONCRETE	14
32 16 13 M DRIVEWAY, SIDEWALK, CURB, GUTTER (Modified).....	15
32 31 13 M CHAIN LINK FENCES AND GATES (Modified)	16
32 31 16 M WELDED WIRE FENCES AND GATES (Modified).....	17
32 31 23 POLY(VINYL CHLORIDE)(PVC) FENCES AND GATES.....	18
32 92 00 M TURF AND GRASS (Modified)	23
DIVISION 33 UTILITIES	
33 05 25 M PAVEMENT RESTORATION (Modified).....	24
33 08 00 M COMMISSIONING OF WATER UTILITIES (Modified).....	25
33 11 00 M WATER DISTRIBUTION AND TRANSMISSION (Modified).....	27
33 12 16 M WATER VALVES (Modified)	31
33 12 19 M HYDRANTS (Modified)	32
33 12 33 M WATER METER (Modified).....	33
33 13 00 M DISINFECTION (Modified)	35

**SECTION 03 20 00 M
CONCRETE REINFORCING (MODIFIED)**

PART 3 EXECUTION

3.1 PLACING

Add paragraphs F and G as follows:

- F. No steel shall extend from or be visible on any finished surface
- G. All steel shall have a minimum of 1.5-inches of concrete cover.

**SECTION 03 30 04 M
CONCRETE (Modified)****PART 2 PRODUCTS****2.5 MIX DESIGN**

Replace Paragraph A with the following:

- A. **Class:** When not specified in the plans or project specifications, use the following table to select the class of concrete required for the application:

Class	Application
5,000	Reinforced Structural Concrete
4,000	Sidewalks, curb, gutter, cross gutters, waterways, pavements, and unreinforced footings and foundations
3,000	Thrust blocks
2,000	Anchors, mass concrete

**SECTION 03 30 10 M
CONCRETE PLACEMENT (Modified)**

PART 3 EXECUTION

3.2 PREPARATION

Add paragraph F as follows:

- F. No concrete shall be placed until the surfaces have been inspected and approved by the City Engineer or City Inspector.

**SECTION 31 23 16 M
EXCAVATION (Modified)**

PART 3 EXECUTION

3.3 GENERAL EXCAVATION REQUIREMENT

Add paragraph I as follows:

- I. Excavation for pipelines under existing curb and gutter, concrete slabs, or sidewalks shall be open cut. Neither tunneling nor water jetting is allowed. At the option of the City Engineer, jacking or boring under permanent facilities may be allowed based on his/her direction.

Add Section 31 23 20 Fill

**SECTION 31 23 20
FILL**

PART 1 GENERAL

1.1 SECTION INCLUDES

- A. Non-structural fill materials.
- B. Non-structural placement and compaction.

1.2 REFERENCES

A. ASTM Standards

- D 698 Laboratory Compaction Characteristics of Soil Using Standard Effort (12,400 ft-lbf/ft³ (600 kN-m/m³)).
- D 1557 Standard Test Methods for Laboratory Compaction Characteristics of Soil Using Modified Effort (56,000 ft-lbf/ft³ (2,700 kN-m/m³)).
- D 2922 Density of Soil and Soil-Aggregate in Place by Nuclear Methods (Shallow Depth).

1.3 SUBMITTALS

- A. When requested by ENGINEER, submit laboratory dry density and optimum laboratory moisture content for each type of fill to be used.

1.4 QUALITY ASSURANCE

- A. Do not change material sources without ENGINEER's knowledge.
- B. Reject material that does not comply with the requirements specified in this Section.

1.5 STORAGE

- A. Safely stockpile materials.
- B. Separate differing fill materials, prevent mixing, and maintain optimum moisture content of materials.

1.6 SITE CONDITIONS

- A. Do not place, spread, or roll any fill material over material that is damaged by water. Remove and replace damaged material at no additional cost to OWNER.
- B. Control erosion. Keep area free of trash and debris. Repair settled, eroded, and rutted areas.
- C. Reshape and compact damaged structural section to required density.

1.7 ACCEPTANCE

- A. General: Native material may be wasted if there is no additional cost to substitute material acceptable to ENGINEER.
- B. Lift thickness: One test per Lot.

- C. Compaction: One test per Lot. Verify density using nuclear tests, ASTM D 2922.
Compaction and Lot sizes as follows:
 - 1. Compact to 92% Standard Proctor
 - 2. One Lot = 1500 square feet per lift

1.8 **WARRANTY**

- A. Repair settlement damage at no additional cost to OWNER.

PART 2 PRODUCTS

2.1 **FILL MATERIALS**

- A. Material shall be free from sod, grass, trash, rocks larger than four (4) inches in diameter, and all other material unsuitable for construction of compacted fills.

2.2 **WATER**

- A. Make arrangements for sources of water during construction and make arrangements for delivery of water to site.
- B. Comply with local Laws and Regulations at no additional cost to OWNER when securing water from water utility company.

PART 3 EXECUTION

3.1 **PREPARATION**

- A. Implement the traffic control plan requirements, Section 01 55 26.
- B. Verify material meets maximum size requirements.
- C. If ground water is in the intended fill zone, dewater.

3.2 **PROTECTION**

- A. Protect existing trees, shrubs, lawns, structures, fences, roads, sidewalks, paving, curb and gutter and other features.
- B. Protect above or below grade utilities. Contact utility companies to repair utility damage. Pay all cost of repairs.
- C. Avoid displacement of and damage to existing installations while compacting or operating equipment.
- D. Do not use compaction equipment adjacent to walls or retaining walls that may cause wall to become over-stressed or moved from alignment.
- E. Restore any damaged structure to its original strength and condition.

3.3 **LAYOUT**

- A. Identify required line, levels, contours, and datum.
- B. Stake and flag locations of underground utilities.

- C. Upon discovery of unknown utility or concealed conditions, notify ENGINEER.
- D. Maintain all benchmarks, control monuments and stakes, whether newly established by surveyor or previously existing. Protect from damage and dislocation.
- E. If discrepancy is found between Contract Documents and site, ENGINEER shall make such minor adjustments in the Work as necessary to accomplish the intent of Contract Documents without increasing the Cost of the Work to CONTRACTOR or OWNER.

3.4 **SUBGRADE**

- A. Protect Subgrade from desiccation, flooding, and freezing.
- B. Before placing fill over Subgrade, get ENGINEER's inspection of subgrade surface preparations.
- C. If Subgrade is not readily compactable get ENGINEER's permission to stabilize the subgrade.

3.5 **TOLERANCES**

- A. Compaction: Ninety-two (92) percent minimum relative to a standard proctor density, Section 31 23 26.
- B. Lift Thickness (before compaction):
 - 1. Eight (8) inches when using riding compaction equipment.
 - 2. Six (6) inches when using hand held compaction equipment.

3.6 **CLEANING**

- A. Remove stockpiles from site. Grade site surface to prevent free standing surface water.
- B. Leave borrow areas clean and neat.

END OF SECTION

**SECTION 31 41 00 M
SHORING (Modified)**

PART 1 GENERAL

1.2 PRICE – MEASUREMENT AND PAYMENT

A. In Trenching, Shoring:

Revise subparagraph 1 to read as follows:

1. A two (2) part Protective System is required if each Side of the Trench is to be shored. The use of a Trench Box shall be classified as one Protective System.

1.4 DESIGN OF PROTECTIVE SYSTEMS

Add paragraphs C and D as follows:

- C. Trenches five (5) feet deep or greater require a protective system unless the excavation is made entirely in stable rock. If less than five (5) feet deep, a competent person may determine that a protective system is not required.
- D. Trenches 20 feet deep or greater require that the protective system be designed by a registered professional engineer or be based on tabulated data prepared and/or approved by a registered professional engineer in accordance with 1926.652(b) and (c).

1.5 SUBMITTALS

Revise paragraph A to read as follows:

- A. Submit a Protective System plan:
 1. When excavation is over twenty (20) feet deep, or
 2. When requested by ENGINEER.

Add Article 1.6 as follows:

1.6 REFERENCES

- A. 29 CFR Part 1910 – Occupational Safety and Health Standards
- B. 29 CFR Part 1926 Subpart P – Excavations

PART 3 EXECUTION

3.4 INSPECTIONS

Add paragraph C as follows:

- C. OWNER and/or ENGINEER may order an immediate work stoppage if working conditions are thought to be unsafe. Work may resume only after proper safety precautions are implemented.

**SECTION 32 01 06 M
STREET NAME SIGNS (Modified)**

PART 1 GENERAL

1.2 REFERENCES

Add paragraph C as follows:

- C. South Weber City Public Works Standard Drawings**

**SECTION 32 01 13.64 M
CHIP SEAL (Modified)**

PART 1 GENERAL

1.2 REFERENCES**A. ASTM Standards:**

Add the following to paragraph A:

- C 29 Standard Test Method for Bulk Density (“Unit Weight”) and Voids in Aggregate
- C 330 Standard Specification for Lightweight Aggregates for Structural Concrete

Rename Article 1.5 as follows:

1.5 WEATHER AND CONDITIONS**D. Temperature**

Add subparagraph 4 as follows:

- 4. Do not place if forecasted temperature is expected to drop below 40 deg F within 72 hours of placement.

B. Moisture and Wind:

Add subparagraph 1 as follows:

- 1. Do not place chip seal coat if surface moisture is present.

PART 2 PRODUCTS

2.1 ASPHALT BINDER

Revise paragraph B as follows:

- A. Emulsified Asphalt: CRS-2P or LMCRS, Section 32 12 03. Use any of the following additives to match aggregate particle charge, weather conditions, and mix design:
(Subparagraphs 1-5 remain unchanged.)

2.2 COVER AGGREGATE**A. Material:**

Revise subparagraph 2 to read as follows:

- 2. 100% Crusher processed rotary kiln lightweight expanded shale chips (Utelite or approved equal).

Replace Table 1 with the following:

Property	ASTM	Min.	Max.
Clay Lumps and Friable Particles, percent	C142	-	2
Bulk Density Dry Loose Condition, lb/ft ³	C29	-	55

B. Gradation: Analyzed on a dry weight and percent passing basis.

Replace Table 2 with the following:

Sieve	ASTM	C330 Requirement
1/2"	C136	100
3/8"		80-100
No. 4		5-40
No. 8		0-20
No 16		0-10
No. 200		0-10

Replace Article 2.3 with the following:

2.3 FOG SEAL/FLUSH COAT

A. Material: Use cationic emulsified asphalt grade CSS-1h, Section 32 12 03.

Add Article 2.4 as follows:

2.4 MIX DESIGN

- A. Select Type and grade of emulsified asphalt, ASTM D 3628.
- B. Use the following application rates, or submit mix design for approval by Engineer.
1. Emulsion: Use Table 3.

Emulsion	Application Rate (gal/sy)
CRS-2P	0.32 – 0.35
LMCRS-2	0.32 – 0.35

2. Cover Material: Use Table 4.

Emulsion	Application Rate (lbs/sy)
CRS-2P	10.0 – 12.0
LMCRS-2	10.0 – 12.0

3. Fog Seal/Flush Coat: Use 0.10 – 0.12 gal/sy at a 2:1 dilution rate.

PART 3 EXECUTION

3.2 PREPARATION

Add paragraph F as follows:

- F. Cover manholes, valves boxes, storm drain inlets, and other service utility features before placing any chip seal coat.

3.4 APPLICATION

Revise paragraph A to read as follows:

- A. Asphalt Emulsion: Keep viscosity between 50 and 100 centistokes during application, ASTM D 2170. Keep temperature to a minimum of 145 deg F.

Revise Article 3.6 to read as follows:

3.6 FOG SEAL/FLUSH COAT

- A. Apply asphalt seal over the chips within 24 hours of placing chips.
 B. Keep viscosity between 50 and 100 centistokes, during application, ASTM D 2170.

**SECTION 32 12 05 M
BITUMINOUS CONCRETE (MODIFIED)**

Revise Section 2.3 as follows:

2.3 ADDITIVES

- A. Mineral Filler: None
- B. Recycle Agent: None
- C. Anti-strip Agent: 1% Lime Slurry, minimum
- D. RAP or ROSP (By weight or binder, whichever is lesser): Allowed up to 15%
 - 1. Free of detrimental quantities of deleterious materials
 - 2. No change in specified binder grade

2.4 MIX DESIGN

Replace paragraph A with the following:

- A. Project Specific Requirements:
 - 1. Road Category: Class II
 - 2. Mix Designator (Compaction Effort): 50 N_d
 - 3. Binder Grade: PG 58-28
 - 4. Master Grading Band: SP-1/2

SECTION 32 16 13 M
DRIVEWAY, SIDEWALK, CURB, GUTTER (Modified)

PART 3 EXECUTION

3.4 CONTRACTION JOINTS

D. Curb, Gutter, Waterway:

Revise subparagraph 1 to read as follows:

1. Place joints at intervals not exceeding 10 feet.

3.5 EXPANSION JOINTS

B. Sidewalks:

Add subparagraph 5 as follows:

5. Expansion joints are to be placed at 48-foot intervals (minimum) or wherever new sidewalk adjoins existing sidewalks, driveways, or aprons.

SECTION 32 31 13 M
CHAIN LINK FENCES AND GATES (Modified)

PART 2 PRODUCTS

2.6 POSTS, CAPS, RAILS, COUPLINGS

- A. Posts, Frames, Stiffeners, Rails: ASTM F 1043:

Revise applicable rows of Table 1 to read as follows:

Top Rail	1-5/8" pipe
----------	-------------

PART 3 EXECUTION

3.6 INSTALLATION OF FENCE FABRIC

Revise paragraph A to read as follows:

- A. Place fence fabric on roadway side of posts unless otherwise specified. Place fabric approximately 1 inch above the grounds. Maintain a straight grade between posts by excavating ground high points and filling depressions with soil.

SECTION 32 31 16 M
WELDED WIRE FENCES AND GATES (Modified)

PART 1 GENERAL

1.2 REFERENCES

Add paragraph D as follows:

- D. UDOT Standard Drawing
 - FG 2A Right of Way Fence and Gates (Metal Post)
 - FG 2B Right of Way Fence and Gates (Metal Post)

PART 3 EXECUTION

3.2 INSTALLATION

Add paragraph N as follows:

- N. Install per UDOT Standard Drawings FG 2A and FG 2B.

Add Section 32 31 23 Poly(Vinyl Chloride)(PVC) Fences and Gates

**SECTION 32 31 23
POLY(VINYL CHLORIDE)(PVC) FENCES AND GATES**

PART 1 GENERAL

1.1 SECTION INCLUDES

- A. PVC fencing, posts, gates, and appurtenances.

1.2 REFERENCES

A. **ASTM Standards:**

- D 1784 Rigid Poly(Vinyl Chloride) (PVC) Compounds and Chlorinated Poly(Vinyl Chloride) (CPVC) Compounds
- F 626 Fence Fittings
- F 964 Rigid Poly(Vinyl Chloride)(PVC) Exterior Profiles Used for Fencing and Railing
- F 1999 Installation of Rigid Poly(Vinyl Chloride)(PVC) Fence Systems

1.3 SUBMITTALS

- A. Drawings: Indicate plan layout, grid, size and spacing of components, accessories, fittings, anchorage, and post section.
- B. Data: Submit manufacturer's installation instructions and procedures, including details of fence and gate installation.
- C. Submit sample of fence fabric and typical accessories.

PART 2 PRODUCTS

2.1 GENERAL

- A. Products from other qualified manufacturers having a minimum of 5 years' experience manufacturing PVC fencing will be acceptable by the architect as equal, if approved in writing, ten days prior to bidding, and if they meet the following specifications for design, size, and fabrication. PVC Profiles, lineals, and extrusions used as components must "meet or exceed" the minimum performance guidelines laid out in ASTM 964.

2.2 PVC FENCE

- A. Pickets, rails, and posts fabricated from PVC extrusion. The PVC extrusions shall comply with ASTM D 1784, Class 14344B and have the following characteristics:

Specific Gravity (+/- 0.02)	1.4
Using 0.125 specimen Izod impact ft. lbs./in. notch	23.0
Tensile strength, PSI	6,910
Tensile modulus, PSI	336,000
Flexural yield strength, PSI	10,104
Flexural modulus, PSI	385,000
DTUL at 264 PSI	67°C

- B. All fence parts made from PVC shall have a minimum thickness of 0.17 in except where specified otherwise.

2.3 POST CAPS

- A. Molded, one piece.
 B. Cross Section: Match post or gate upright cross section.
 C. Thickness: 0.095" minimum.
 D. Configuration: Flat or four-sided as required for installation to top of posts and gate.

2.4 ACCESSORIES

- A. Standard gate brace, screw caps, rail end reinforcers, and other accessories as required.

2.5 MISCELLANEOUS MATERIALS

- A. Stiffener Chemicals: Galvanized steel structural channel. Configure channels for concealed installation within PVC rails with pre-drilled holes for drainage. Aluminum extruded channel available upon request.
1. Cross Section: 3.00" x 3.00" x 1.500" hourglass shape to grip picket.
 2. Thickness: 0.040 Gauge (minimum)
- B. Fasteners and Anchorage: Stainless Steel. All fasteners to be concealed or colored heads to match. Provide sizes as recommended by fence manufacturer.
- C. PVC Cement: As recommended by fence manufacturer.

2.6 GATE HARDWARE AND ACCESSORIES

- A. General: Provide hardware and accessories for each gate according to the following requirements.
- B. Hinges: Size and material to suit gate size, non-lift-off type, self-closing, glass filled nylon with stainless steel adjuster plate, offset to permit 120 degree gate opening. Provide one pair of hinges for each gate.
1. Stainless Steel, painted with carbo zinc base.
 2. Finish: Pre-painted, 2 coats "Polane."
 3. Color: Black Gravity Latch or dual access gravity latch.
- C. Latch: Manufacturers' standard self-latching, thumb latch, pre-finished steel, or stainless steel gravity latch. Provide one latch per gate.

1. Finish: Match gate hinge finish.
 - D. Hardware: Stainless Steel. Provide sizes as recommended by fence manufacturer.
 1. Finish: Match gate hinge finish.
- 2.7 **CONCRETE**
- A. Use Class 3000 concrete. Section 03 30 04.
- 2.8 **REINFORCING FOR FILLED POSTS**
- A. Steel Reinforcing:
 1. Steel Reinforcing Bars: ASTM A 615. Grade 60. Deformed (#4 or ½").
 2. Install 2 bars for each corner or gate post as specified in the drawings.

PART 3 EXECUTION

3.1 PREPARATION

- A. Locate and preserve utilities, Section 31 23 16.
- B. Excavation, Section 31 23 16.
- C. Review to ASTM F 567 and CLFMI products manual for chain link fence installation.
- D. Protect roots and branches of trees and plants to remain.
- E. Limit amount of clearing and grading along fence line to permit proper installation.

3.2 LAYOUT OF WORK

- A. Accurately locate and stake locations and points necessary for installation of fence and gates.
- B. General arrangements and location of fence and gates are indicated. Install except for minor changes required by unforeseen conflicts with work of other trades.

3.3 INSTALLATION – GENERAL

- A. Install fence in compliance with manufacturer's written instructions.
- B. PVC components shall be carefully handled and stored to avoid contact with abrasive surfaces.
- C. Install components in sequence as recommended by fence manufacturer.
- D. Install fencing as indicated on the drawings provided.
- E. Variations from the installation indicated must be approved.
- F. Variations from the fence and gate installation indicated and all costs for removal and replacement will be the responsibility of the CONTRACTOR.

3.4 INSTALLATION OF POSTS

- A. Excavation
 1. Drill or hand-excavate (using post hole digger) holes for posts to diameters and spacings indicated, in firm, undisturbed or compacted soil.

2. If not indicated on drawings, excavate holes for each post to a minimum diameter of 12 inches.
3. Unless otherwise indicated, excavate hole depths not less than 30 inches or to frost line.

B. Posts

1. Install posts in one piece, plumb and in line. Space as noted in the drawings. Enlarge excavation as required to provide clearance indicated between post and side of excavation.
2. Protect portion of posts above ground from concrete splatter. Place concrete around posts and vibrate or tamp for consolidation. Check each post for vertical and top alignment and hold in position during placement and finishing operations.
 - a. Unless otherwise indicated, terminate top of concrete footings 3 inches below adjacent grade and trowel to a crown to shed water.
 - b. Secure posts in position for manufacturer's recommendations until concrete sets.
 - c. After installation of rails and unless otherwise indicated, install reinforcing in posts in opposing corners of post as shown and fill end and gate posts with concrete to level as indicated. Concrete fill shall completely cover the reinforcing steel and gate hardware fasteners. Consolidate the concrete by striking the post face with a rubber mallet, carefully tamping around the exposed post bottom.
 - d. Install post caps. Use #8 screws, nylon washers and snap caps.
 - e. Remove concrete splatters from PVC fence materials with care to avoid scratching.

3.5 INSTALLATION OF RAILS

A. Top and Bottom Rails

1. Install rails in one piece into routed hole fabricated into posts to receive top and bottom rails, and middle where necessary. Except at sloping terrain, install rails level.
 - a. Prior to installation of rails into posts, insert concealed steel channel stiffeners in top rail, where necessary. Bottom rails shall include minimum 2- $\frac{1}{4}$ " drainage holes.
 - b. At posts to receive concrete fill, tape rail ends to prevent seepage when filling post with concrete.

B. Middle Rails:

1. Where necessary, install middle rails in one piece into routed hole in posts with larger holes facing down. Except at sloping terrain, install middle rails level. Secure mid rail to pickets with 2-#8 x 1- $\frac{1}{2}$ " screws evenly spaced.
 - a. At posts to receive concrete fill, tape rail ends to prevent seepage when filling post with concrete.

3.6 INSTALLATION OF FENCE FABRIC/PICKETS

- A. Pickets:** Install pickets in one piece as per manufacturer recommendations. Install pickets plumb.

3.7 INSTALLATION ON SLOPING TERRAIN

- A. At sloping terrain rails may be racked (sloped) or stepped to comply with manufacturer's recommendations.

3.8 INSTALLATION OF GATES

- A. Prior to installation of rails into posts, apply PVC cement into sockets per manufacturer's recommendations. Bottom rail shall include minimum 2-¼" drainage holes.
- B. Assemble gate prior to fence installation to accurately locate hinge and latch post. Align gate horizontal rails with fence horizontal rails.
- C. Install gates plumb, level, and secure for full opening without interference according to manufacturer's instructions.
- D. Gate Latch Installation. Install gate latch according to manufacturer's instructions.
- E. Allow minimum 72 hours to let concrete set-up before opening gates.

END OF SECTION

**SECTION 32 92 00 M
TURF AND GRASS (Modified)**

PART 1 GENERAL

1.3 SUBMITTALS

Add paragraph C as follows:

- C. Submit seed mix.

PART 2 PRODUCTS

2.1 SEED

Add paragraph D as follows:

- D. Seed Mix:

<u>SEED #</u>	<u>BOTANICAL NAME</u>	<u>COMMON NAME</u>	<u>% by Weight</u>
1	Agropyron cristatum 'Fairway'	Fairway Crested Wheatgrass	15%
2	Agropyron riparium 'Sodar'	Streambank Wheatgrass	20%
3	Bromus inermis 'Manchar'	Smooth Brome	32%
4	Fescue rubra 'Fortress'	Red Fescue	25%
5	Poa compressa 'Reuben's'	Reuben's Canadian Bluegrass	6%
6	Trifolium repens	White Dutch Cover	2%

PART 3 EXECUTION

3.4 SEEDING

Revise paragraph A to read as follows:

- A. Apply seed at a rate of eight (8) pounds per 1,000 square feet evenly in two (2) intersecting directions. Rake in lightly.

**SECTION 33 05 25 M
PAVEMENT RESTORATION (Modified)**

PART 1 GENERAL

1.2 REFERENCES

Replace paragraph A to read as follows:

- A. South Weber City Public Works Standard Drawings**

PART 2 PRODUCTS

2.2 ASPHALT PAVEMENT

Revise paragraph A to read as follows:

- A. Permanent Warm Weather Asphalt Concrete: Section 32 12 05 M unless indicated otherwise.**

Revise paragraph C to read as follows:

- C. Pavement Sealing:**
- 1. Crack Seal: Section 32 01 17**
 - 2. Chip Seal: Section 32 01 13.64 and 32 01 13.64 M.**
 - 3. Fog Seal: Section 32 01 13.50.**

PART 3 EXECUTION

3.5 ASPHALT PAVEMENT RESTORATION

Revise paragraphs A and B to read as follows:

- A. Follow South Weber City Public Works Standard Drawings.**
- B. Match existing pavement thickness or 4-inches minimum, whichever is greater.**

SECTION 33 08 00 M
COMMISSIONING OF WATER UTILITIES (Modified)

PART 3 EXECUTION

3.5 INFILTRATION TEST

Revise paragraph A to read as follows:

- A. General: 150 gallons per inch diameter per mile per day. If the ground water table is less than two (2) feet above the crown of the pipe, the infiltration test is not required.

Revise Article 3.6 in its entirety to read as follows:

3.6 EXFILTRATION TEST

A. Non-Pressurized System:

- 1. General: Air test or hydrostatic test is CONTRACTOR's choice.
- 2. Air Test:
 - a. Plastic Pipe: ASTM F 1417.
 - (i) For pipe up to 30 inches diameter, pressure drop is 0.5 psi.
 - (ii) For pipe larger than 30 inches diameter, isolated joint test is 3.5 psi maximum pressure drop is 1.0 psi in 5 seconds.
 - b. Concrete Pipe:
 - (i) ASTM C 1214 for concrete pipe 4" to 24" diameter.
 - (ii) ASTM C 1103 for concrete pipe 27" and larger.
- 3. Hydrostatic Test: Provide air release taps at pipeline's highest elevations and expel all air before the test. Insert permanent plugs after test has been completed.
 - a. Plastic Pipe: ASTM F 2497.
 - b. Concrete Pipe: ASTM C 497. Abide by Section 3 and Section 16 in the ASTM standard and applicable recommendations of manufacturer.

B. Pressurized System:

- 1. Pressure Test: All newly laid pipe segments and their valves, unless otherwise specified, shall be subjected to a hydrostatic pressure test of 225 psi or 50 psi above working pressure, whichever is higher. The hydrostatic pressure test shall be conducted after the pipe segments have been partially backfilled.
- 2. Duration of Pressure Test: The duration of each hydrostatic pressure test shall be at least two (2) hours.
- 3. Test Procedure: Each pipe segment shall be slowly filled with water and the specified test pressure, measured at the point of lowest elevation, shall be applied by means of a pump connected to the pipe in a satisfactory manner. Testing against closed valves will be allowed. The pump, pipe connection, and all necessary apparatus including gauges

and meters shall be furnished by the CONTRACTOR. CONTRACTOR shall provide all labor and equipment necessary to perform the test.

4. Expelling Air Before Test: Before applying the specified test pressure, all air shall be expelled from the pipe. To accomplish this, air release mechanisms shall be installed, if necessary, at points of highest elevation, and afterwards tightly capped.
5. Examination Under Pressure: All pipes, fittings, valves, hydrants, joints, and other hardware will be subject to examination under pressure during the hydrostatic test. Any defective pipes, fittings, hydrants, valves, or other hardware discovered in consequence of this pressure test shall be removed and replaced by the CONTRACTOR with sound material, at no expense to the OWNER, and the test shall be repeated until the ENGINEER is satisfied.
6. No piping installation will be acceptable until the leakage is less than the amount allowed by industry standards for the type of pipe material being tested. Or, if no standard prevails, then the number of gallons per hour is determined by the formula:

$$Q = \frac{LD\sqrt{P}}{148,000}$$

Where: Q = allowable leakage, gallons per hour
L = length of pipe under test, feet
D = diameter of pipe, inches
P = average test pressure, psig

**SECTION 33 11 00 M
WATER DISTRIBUTION AND TRANSMISSION (Modified)**

PART 1 GENERAL

1.2 REFERENCES

Revise paragraph B to read as follows:

B. South Weber City Public Works Standard Drawings

Add to paragraph C. AWWA Standards:

C105	Polyethylene Encasement for Ductile Iron Pipe Systems
C110	Ductile-Iron and Gray-Iron Fittings
C111	Rubber-Gasket Joints for Ductile-Iron Pressure Pipe and Fittings
C223	Fabricated Steel and Stainless Steel Tapping Sleeves
M14	AWWA Recommended Practice for Backflow Prevention and Cross-Connection Control

Add paragraph F as follows:

F. ANSI/NSF Standards:

61	Drinking Water System Components – Health Effects
----	---

1.3 PERFORMANCE REQUIREMENTS

Replace paragraph A with the following:

A. Depth of Cover:

1. Minimum as indicated on the drawings. If minimum cannot be achieved, contact ENGINEER.
2. Maximum of 72 inches unless indicated on the plans or approved by ENGINEER.

1.5 SITE CONDITIONS

Revise paragraph D to read as follows:

- D. Do not operate any water valve until its owner and water company's permission is secured.

PART 2 PRODUCTS

2.1 PIPES AND FITTINGS

Revise paragraph A to read as follows:

- A. Provide piping materials and factory fabricated piping products of sizes, types, pressure ratings, and capacities indicated. Use only NSF 61 approved products in drinking water systems. All such products shall be appropriately stamped with the NSF logo.

Add paragraphs E and F as follows:

- E. Mechanical Joint Fittings: Ductile iron, Class 250
- F. Flanged Fittings: Ductile iron, Class 250

2.3 VALVE BOX

Revise paragraph A to read as follows:

- A. Buried Valves in Traffic Areas: Cast iron two (2) piece slip sleeve type, 5-1/4 inch shaft, with a drop lid, rated for HL-93 loading.

Revise paragraph C to read as follows:

- C. Markings: Potable water main line valves box covers shall contain the wording "SOUTH WEBER WATER."

Add Articles 2.9 and 2.10 as follows:

2.9 TAPPING SLEEVE AND VALVE

- A. AWWA C223.
- B. Sleeve shall be full circumferential seat with all stainless steel tapping sleeve.
- C. Flanged outlet with flanged by MJ valve.

2.10 FIRE SPRINKLER/SUPPRESSION LINES

- A. Lines:
 - 1. Ductile iron, Class 51, or as approved in writing by OWNER or ENGINEER.
 - 2. Meet all specifications for main lines.
- B. Valve:
 - 1. All fire lines shall be equipped with an isolation gate valve located at the main line.

PART 3 EXECUTION

3.4 INSTALLATION – PIPE AND FITTING

A. General:

Add subparagraphs 3 through 7 as follows:

3. Encase all buried ductile iron valves, fitting, connections, and specialties in minimum 8 mil. polyethylene sheets in accordance with AWWA C105.
4. Waterline shall be laid and maintained to lines and grades established by the drawings, with fittings and valves at the required locations. Deviations as approved in writing by OWNER or ENGINEER.
5. Lay water lines on a continuous grade to avoid high points except as shown on the plans.
6. Cut edges and rough ends shall be ground smooth. Bevel end for push-on connections.
7. Do not drop pipe or fittings into trench.

Add paragraph I as follows:

I. Tie-Ins:

1. All tie-ins shall be made dry and not on a day proceeding a weekend or holiday.
2. OWNER requires 48-hours' notice for water turn-off.
3. At least 24-hours prior to a service disruption, CONTRACTOR shall notify all affected water users.
4. Where shutting down a line is not feasible as determine by OWNER or ENGINEER, CONTRACTOR shall make a wet tap using a tapping sleeve and valve.

3.5 INSTALLATION – CONCRETE THRUST BLOCK

Revise paragraph A to read as follows:

- A. South Weber City Public Works Standard Drawings.

3.8 INSTALLATION – TAPS

Revise paragraph A to read as follows:

- A. South Weber City Public Works Standard Drawings.

3.9 INSTALLATION – SERVICE LINE

Revise paragraph C to read as follows:

- C. Meter Box: South Weber City Public Works Standard Drawings.

Add paragraph D as follows:

- D. New Water Service Line
 - 1. 1" Service
 - a. All laterals must be of one continuous copper tube between the corp stop and the meter box. No joints or copper to copper connectors are allowed.
 - 2. 1.5" and 2" Services
 - a. All solder joints shall be 95-5 solder or better, or Mueller compression fittings.

3.10 INSTALLATION – WATERMAIN LOOP (SYPHON)

Revise paragraph A to read as follows:

- A. South Weber City Public Works Standard Drawings.

3.12 BACKFILLING

- B. Trenches: Section 33 05 20:

Revise subparagraphs 1 and 2 to read as follows:

- 1. Pipe zone backfill, South Weber City Public Works Standard Drawings.
- 2. Trench backfill, South Weber City Public Works Standard Drawings.

3.13 SURFACING RESTORATION

- A. Roadway Trenches and Patches: Section 33 05 25:

Revise subparagraphs 1 and 2 to read as follows:

- 1. Asphalt concrete patch, South Weber City Public Works Standard Drawings.
- 2. Concrete pavement patch, contact OWNER for instructions.

Add new Article 3.14 as follows:

3.14 FIRE SPRINKLER/SUPPRESSION LINES

- A. Notify OWNER 48 hours prior to installation.
- B. Unless written authorization is given by OWNER, no services shall be connected to the fire sprinkler/suppression lines.
- C. Location: As approved by OWNER.

**SECTION 33 12 16 M
WATER VALVES (Modified)**

PART 1 GENERAL

1.2 REFERENCES

Add paragraph B as follows:

B. South Weber City Public Works Standard Drawings

PART 2 PRODUCTS

2.1 VALVES – GENERAL

A. Underground:

Add subparagraph 3 as follows:

3. Valves over five (5) feet in depth shall have a valve nut extension stem.

2.2 GATE VALVES

Add paragraph D as follows:

D. Model: Mueller A-2361

Add Article 2.10 as follows:

2.10 AIR/VACUUM RELIEF VALVES

- A. Operation:** Relieve air build-up and/or allow intrusion of air to prevent vacuum conditions within pipe.
- B. Location:** Valve and vent placement location as approved by OWNER or ENGINEER.
- C. Connection:** Service saddle.

PART 3 EXECUTION

3.1 INSTALLATION

Add paragraphs D, E, and F as follows:

- D. Prior to installation, inspect valves for direction of opening, freedom of operation, tightness of pressure-containing bolting, and cleanliness of valve ports and seating surfaces.**
- E. Examine all valves for damage or defects immediately prior to installation.**
- F. Mark and hold defective materials for inspection by OWNER or ENGINEER. Replace rejected materials.**

**SECTION 33 12 19 M
HYDRANTS (Modified)**

PART 1 GENERAL

1.2 REFERENCES

Revise paragraph A to read as follows:

- A. **South Weber City Public Works Standard Drawings**

PART 2 PRODUCTS

2.1 DRY-BARREL FIRE HYDRANT

Add paragraph C as follows:

- C. Model: Mueller Super Centurion.

2.2 VALVES

Revise paragraph A to read as follows:

- C. Gate Valve: Section 33 12 16.

2.3 ACCESSORIES

Revise paragraph D to read as follows:

- D. Valve Box, Valve Chamber: Section 33 11 00.

PART 3 EXECUTION

3.2 INSTALLATION

Revise paragraph A to read as follows:

- C. Install hydrant according to South Weber City Public Works Standard Drawings and AWWA M17.

Revise paragraph H to read as follows:

- H. Install thrust block according to South Weber City Public Works Standard Drawings.

**SECTION 33 12 33 M
WATER METER (Modified)**

PART 1 GENERAL

1.2 REFERENCES

Add paragraph B as follows:

- E. South Weber City Public Works Standard Drawings.**

PART 2 PRODUCTS

2.2 METERS FOR SERVICE PIPING

Revise paragraph A to read as follows:

- F. OWNER shall supply and set all 1” meters. All other meters supplied and set by CONTRACTOR.**

2.3 SERVICE LINE, VALVES, AND FITTINGS

Revise paragraph A to read as follows:

- A. Service Pipe: Type K Copper, Section 33 05 03, with compression copper fittings made of brass.**

Revise paragraph B to read as follows:

- B. Service Valves and Fittings:**
- 1. AWWA C800.**
 - 2. 1-Inch Service Laterals – Brass corporation stops with CC thread.**
 - 3. 1.5-Inch and 2-Inch Service Laterals – Copper or brass screw-type fittings (ball valves, strainers, nipples, tees, bends, etc.).**
 - 4. 3-Inch and 4-Inch Service Laterals**
 - a. Ductile iron pipe.**
 - b. Cast iron, flanged valves and fittings.**
 - 5. Greater than 4-Inch – Coordinate with and obtain approval from OWNER and ENGINEER.**

Replace Article 2.4 with the following:

2.4 METER BOXES

- A. See South Weber City Public Works Standard Drawings.**

PART 3 EXECUTION

3.1 INSTALLATION

Revise paragraph D to read as follows:

- D. OWNER Supplied Meters: Installed by OWNER unless indicated otherwise.

Add paragraphs E and F as follows:

- E. Install one solid piece of copper pipe from main to meter.
- F. Install service laterals with 48-inches of cover, minimum.

**SECTION 33 13 00 M
DISINFECTION (Modified)**

PART 1 GENERAL

1.4 SUBMITTALS

Delete paragraphs B, C, and D in their entirety.

Add Article 1.8 as follows:

1.8 WORK PERFORMED BY OWNER

- A. OWNER will perform bacteriological and high chlorine sampling and testing. CONTRACTOR shall provide all other work associated with this Section.

PART 3 EXECUTION

3.1 PREPARATION

Add paragraphs C and D as follows:

- C. Notify OWNER at least 72 hours prior to any flushing or disinfecting.
- D. Install temporary connections for flushing water lines after disinfection. After the satisfactory completion of the flushing work, remove and plug the temporary connection.

3.2 DISINFECTION OF WATER LINES

Revise paragraph D to read as follows:

- D. Coordinate with OWNER to collect a bacteriological water sample at end of line to be tested. If sample fails bacteriological test, flush system and retest. Continue flushing and retesting until sample passes test.

Revise paragraph G to read as follows:

- G. After a passing bacteriological test sample is obtained, let the system relax for 24 hours. Flush and coordinate with OWNER to collect a subsequent bacteriological sample for testing. If the subsequent test passes, then water line is acceptable.

3.5 FIELD QUALITY CONTROL

- A. Bacteriological Test:

Revise subparagraphs 1 and 2 to read as follows:

1. Coordinate with OWNER to collect samples for testing no sooner than 16 hours after system flushing.
2. OWNER will have water samples analyzed per State of Utah requirements.

Add Article 3.6 as follows:

3.6 SPECIAL PROCEDURE FOR TAPPING SLEEVES

- A. Before a tapping sleeve is installed, the exterior of the main to be tapped shall be thoroughly cleaned, and the interior surface of the sleeve shall be lightly dusted with calcium hypochlorite powder.

APPENDIX C - SOUTH WEBER CITY PUBLIC WORKS STANDARD DRAWINGS

SOUTH WEBER CITY CORPORATION PUBLIC WORKS STANDARD DRAWINGS

Index of Drawings

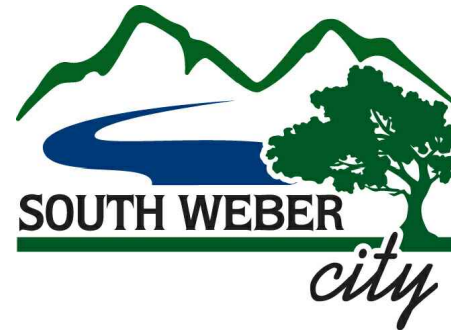

SUBMITTED & RECOMMENDED

BRANDON K. JONES P.E.
SOUTH WEBER CITY ENGINEER

DATE

APPROVAL

TAMARA LONG
SOUTH WEBER CITY MAYOR

DATE

TOM SMITH
SOUTH WEBER CITY MANAGER

DATE

MARK B. LARSEN
SOUTH WEBER CITY PUBLIC WORKS DIRECTOR

DATE

MARK McRAE
ATTEST, SOUTH WEBER CITY RECORDER

DATE



- CS-01.....TITLE PAGE & INDEX OF DRAWINGS***
- CS-02.....PUBLIC ROADS - TYPICAL LOCAL STREET SECTION & UTILITY LATERAL CONFIGURATION DETAILS***
- CS-03.....PUBLIC ROADS - SOUTH WEBER DRIVE & OLD FORT ROAD TYPICAL CROSS SECTION DETAILS***
- CS-04.....PUBLIC ROADS - TYPICAL INTERSECTION & STREET DETAILS***
- CS-05.....PUBLIC ROADS - TYPICAL DRIVE APPROACH, ASPHALT PATCH & DEFECTIVE CONCRETE REPLACEMENT DETAILS***
- CS-06.....PUBLIC ROADS - TYPICAL ADA RAMP, SIDEWALK, CURB & GUTTER, AND CONCRETE JOINT DETAILS***
- CS-07.....PUBLIC ROADS - CUL-DE-SAC & TEMP. TURNAROUND DETAILS***
- CS-08.....CULINARY WATER - RESIDENTIAL WATER SERVICE DETAILS***
- CS-09.....CULINARY WATER - AIR/VACUUM RELIEF STATION & FIRE HYDRANT DETAILS***
- CS-10.....CULINARY WATER - TRACING WIRE INSTALLATION DETAILS***
- CS-11.....CULINARY WATER - STANDARD WATER METER STATIONS***
- CS-12.....CULINARY WATER - PRESSURE REDUCTION STATION***
- CS-13.....CULINARY WATER - THRUST BLOCK, WATERLINE LOOP, PIPE TRENCH & MISC. VAULT DETAILS***
- CS-14.....SANITARY SEWER - LATERAL & CONNECTION DETAILS***
- CS-15.....SANITARY SEWER - TYPICAL MANHOLES & DETAILS***
- CS-16.....STORM DRAIN - SINGLE AND DOUBLE CATCH BASIN DETAILS***
- CS-17.....STORM DRAIN - DRAINAGE INLET BOX & GENERAL GRATE AND FRAME DETAILS***
- CS-18.....STORM DRAIN - MANHOLE DETAILS***
- CS-19.....STORM DRAIN - LARGE DETENTION BASIN DETAILS***
- CS-20.....STORM DRAIN - SMALL DETENTION BASIN DETAILS***
- CS-21.....GENERAL - CHAIN LINK FENCE DETAILS***
- CS-22.....GENERAL - STREET LIGHTING STANDARDS***
- CS-23.....GENERAL - LID (LOW IMPACT DEVELOPMENT) EXAMPLES***

***ADOPTED
OCTOBER XX, 2017***

GENERAL NOTES:

1. PROVIDE 4" THICKNESS OF 3/4" OR 1" UNTREATED BASE COURSE UNDER SIDEWALK, DRIVEWAY APPROACHES AND CURB & GUTTER, COMPACTED TO 95%, PER ASTM D-1557.
2. THESE PAVEMENT THICKNESS SHALL BE CONSIDERED AS CITY MINIMUMS AND MAY BE INCREASED BY THE CITY ENGINEER WHEN A GREATER DEPTH IS NECESSARY TO PROVIDE SUFFICIENT STABILITY. DESIGNER AND/OR DEVELOPER MAY SUBMIT AN ALTERNATIVE PAVEMENT DESIGN BASED ON A DETAILED SOILS ANALYSIS FOR APPROVAL BY THE CITY ENGINEER WHICH MAY MODIFY PAVEMENT THICKNESS, BUT IN NO CASE SHALL THE BITUMINOUS SURFACE COURSE BE LESS THAN 4" AND UNTREATED BASE COURSE LESS THAN 12" THICK.
3. ALL ROAD CUTS SHALL BE PATCHED PER CS-05 AND CS-13
4. CURB & GUTTER AND SIDEWALKS SHALL BE CONSTRUCTED USING FIBER REINFORCED CONCRETE AND IN COMPLIANCE WITH SOUTH WEBER CITY TECHNICAL SPECIFICATIONS AND THESE DRAWINGS.
5. ALL CULINARY WATER MAINS AND SERVICES MUST MAINTAIN A MINIMUM SEPARATION FROM ALL SEWER MAINS AND LATERALS OF 10'-0" HORIZONTAL AND 18" VERTICAL IN ACCORDANCE WITH THE STATE OF UTAH DIVISION OF DRINKING WATER RULES SECTION R309-550-7
6. THE 6'-0" SIDEWALK SHOWN ABOVE IS TO BE CONSIDERED THE "CITY STANDARD." OTHER LOCATIONS AND TYPES OF SIDEWALK AS REQUESTED BY THE DEVELOPER MUST BE APPROVED BY THE CITY. IF SIDEWALK IS LOCATED AGAINST THE TBC, IT MUST BE A MINIMUM OF 6 FEET IN WIDTH.
7. NATURAL GAS TYPICALLY LOCATED IN THE PARKSTRIP, POWER AND COMMUNICATION LINES TYPICALLY LOCATED BEHIND PROPERTY LINES OR IN LOT EASEMENTS.
8. "SEAL COAT" CONSISTS OF THE FOLLOWING:
 - a. CHIP SEAL PER APWA 32 01 13.64 AND CITY MODIFICATIONS, AND
 - b. FOG SEAL PER APWA 32 01 13.50 AND CITY MODIFICATIONS.
9. IMPORTED FILL UNDER ROADWAY SHALL BE GRANULAR BORROW 2" MAX.

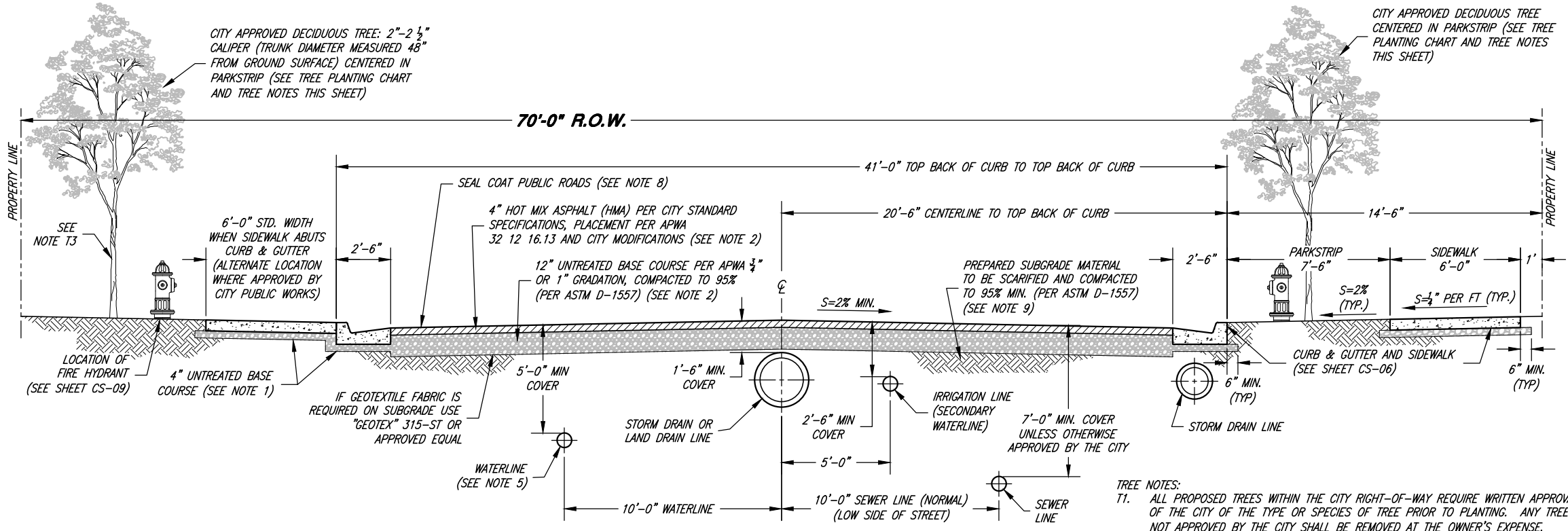

- TREE NOTES:**
- T1. ALL PROPOSED TREES WITHIN THE CITY RIGHT-OF-WAY REQUIRE WRITTEN APPROVAL OF THE CITY OF THE TYPE OR SPECIES OF TREE PRIOR TO PLANTING. ANY TREE NOT APPROVED BY THE CITY SHALL BE REMOVED AT THE OWNER'S EXPENSE.
 - T2. ALL PLANTED TREES TO BE SPACED IN ACCORDANCE WITH THE SPECIES CHARACTERISTICS SUCH THAT THE TREES' CROWNS AT MATURITY WILL NOT OVERLAP WITH ANOTHER TREE NOR TOUCH OR OVERHANG A BUILDING.
 - T3. FOR ADDITIONAL HELP WITH TREE SELECTION VISIT WWW.TREEBROWSER.ORG FOR FURTHER INFORMATION ON NATIVE AND INTRODUCED TREES GROWING IN UTAH AND THE INTERMOUNTAIN WEST.
 - T4. THE PLANTING OF TREES IN THE PARKSTRIP MAY BE A REQUIREMENT OF THE DEVELOPMENT IF DEEMED NECESSARY BY THE CITY.

TREE PLANTING CHART				
SIZE	MATURE HEIGHT	CONCRETE OFFSET	STREET CORNER/FH	POWER/UTILITY DISTANCE
LARGE	OVER 40 FEET	8 FEET MIN. DISTANCE	30 FEET FROM STREET CORNER & 10 FEET FROM ANY FIRE HYDRANT	10 LATERAL FEET OF ANY OVERHEAD UTILITY WIRE & 5 LATERAL FEET OF ANY UNDERGROUND UTILITY LINE
MEDIUM	25 FEET TO 40 FEET	6 FEET MIN. DISTANCE		
SMALL	LESS THAN 25 FEET	3 FEET MIN. DISTANCE		

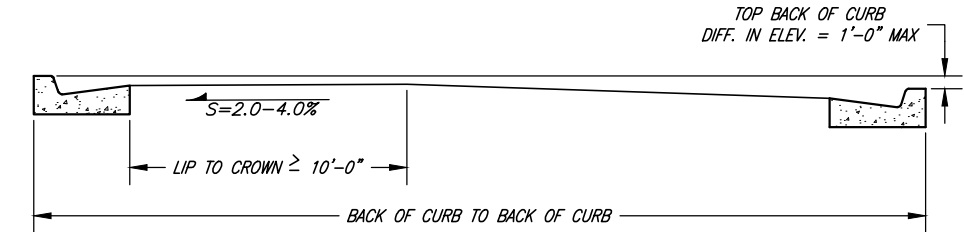
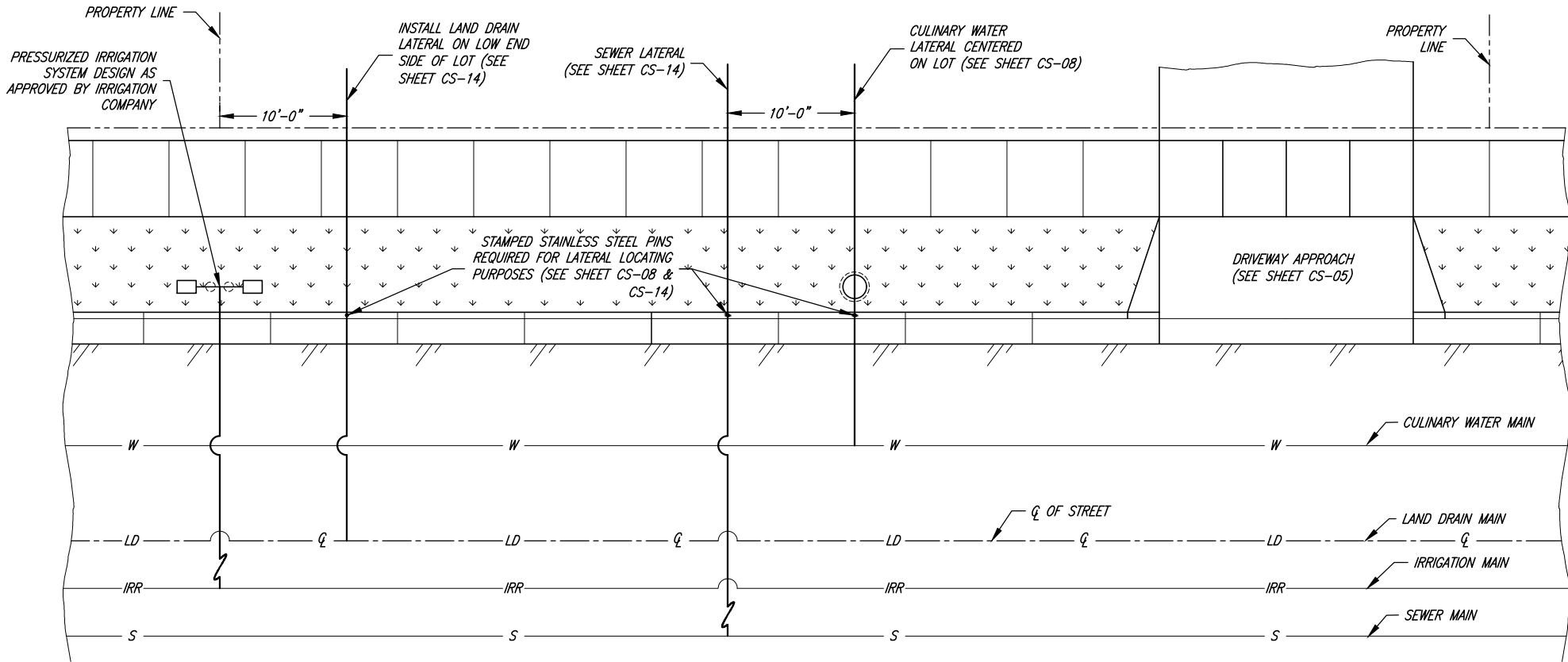

- CROWN NOTES:**
- A. MAXIMUM DIFFERENCE IN ELEVATION BETWEEN CURBS ON OPPOSITE SIDES OF THE STREET SHALL NOT EXCEED 1'-0" AS SHOWN IN DETAIL.
 - B. ON CERTAIN STREETS APPROVED BY THE CITY COUNCIL, THE CITY ENGINEER WILL PROVIDE A PAVEMENT DESIGN. LOCATION OF SIDEWALK AND CURB & GUTTER MAY VARY PER DIRECTION OF THE CITY ENGINEER.
 - B. ALL STREET CROSS SECTIONS SHALL BE AS APPROVED BY THE CITY ENGINEER.

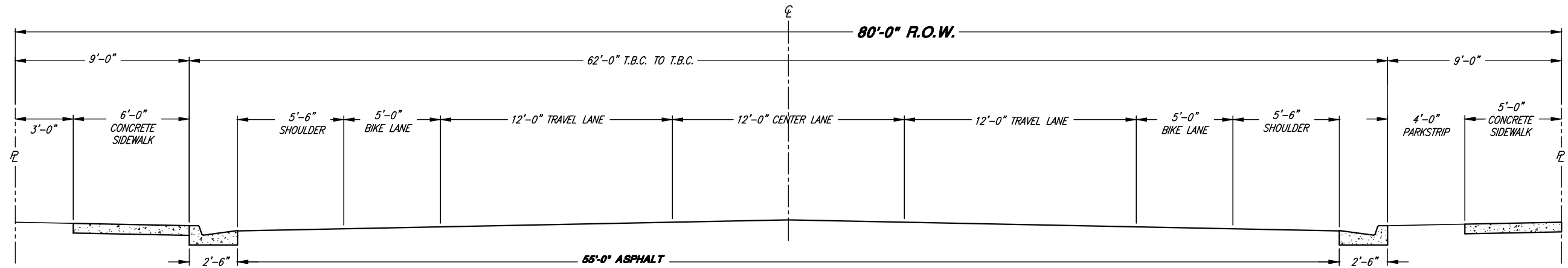

SOUTH WEBER DRIVE R.O.W. SECTION

THE 80'-0" ROADWAY SECTION SHOWN ABOVE IS TO BE CONSIDERED THE "CITY STANDARD" FOR SOUTH WEBER DRIVE. WHERE DESIGNATED BY THE CITY ON A CASE BY CASE BASIS IN AREAS OF PRE-EXISTING ROADWAY IMPROVEMENTS, ALTERNATE STREET CROSS SECTION DESIGNS MAY BE USED WITH THE PRIOR APPROVAL OF THE CITY ENGINEER AND THE CITY PUBLIC WORKS DEPARTMENT. SUBMIT ENGINEERED CONSTRUCTION PLANS TO THE CITY ENGINEER FOR REVIEW AND WRITTEN ACCEPTANCE PRIOR TO CONSTRUCTION.

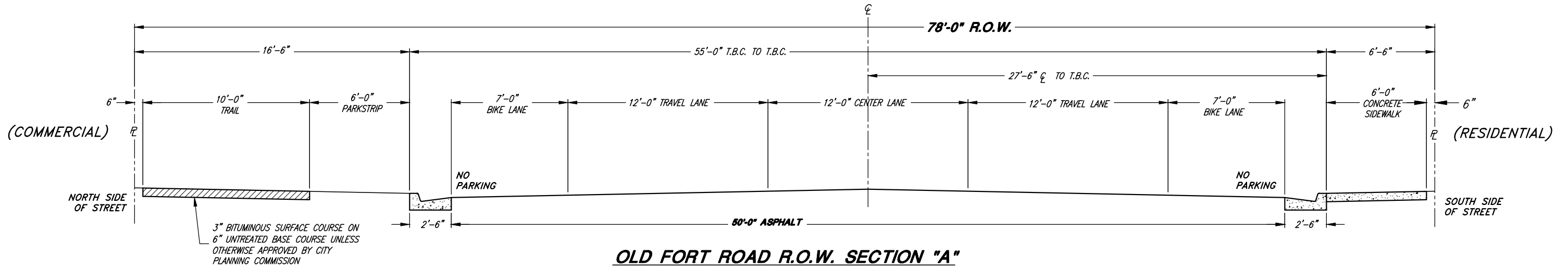

OLD FORT ROAD R.O.W. SECTION "A"

(475 EAST TO POWER SUBSTATION)

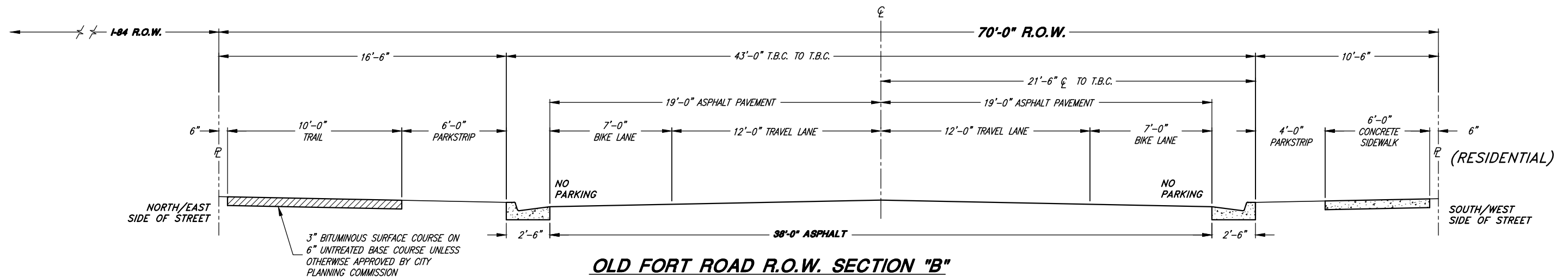

OLD FORT ROAD R.O.W. SECTION "B"

(POWER SUBSTATION TO CONNECTION AT COTTONWOOD COVE SUBDIVISION)

PROJECT ENGINEER			
DATE	REV.	DATE	APPR.

SCALE:

N. T.S.

DESIGNED BKJ
DRAWN BEB
CHECKED BKJ



CONSULTING ENGINEERS
6080 Fashion Point Drive
South Ogden, Utah 84403 (801) 476-9767
www.jonescivil.com

SOUTH WEBER CITY CORPORATION
PUBLIC WORKS STANDARDS
PUBLIC ROADS - SOUTH WEBER DRIVE & OLD FORT ROAD
TYPICAL ROADWAY CROSS SECTION DETAILS

SHEET:
CS-03
OF 23 SHEETS
0

STREET NOTES:

- PRESSURIZED IRRIGATION SYSTEM DESIGN AS APPROVED BY EITHER THE WEBER BASIN WATER CONSERVANCY DISTRICT, SOUTH WEBER WATER IMPROVEMENT DISTRICT, DAVIS AND WEBER COUNTIES CANAL COMPANY, OR THE SOUTH WEBER IRRIGATION COMPANY.
- EXACT LOCATION OF STREET AND REGULATORY SIGNS SHALL BE SPECIFIED BY THE PUBLIC WORKS DIRECTOR FOR SPECIFIC INTERSECTIONS.
- THE NUMBER OF VALVES REQUIRED AT EACH INTERSECTION SHALL BE DETERMINED BY THE CITY ENGINEER.

(NOTES CONTINUED BELOW)

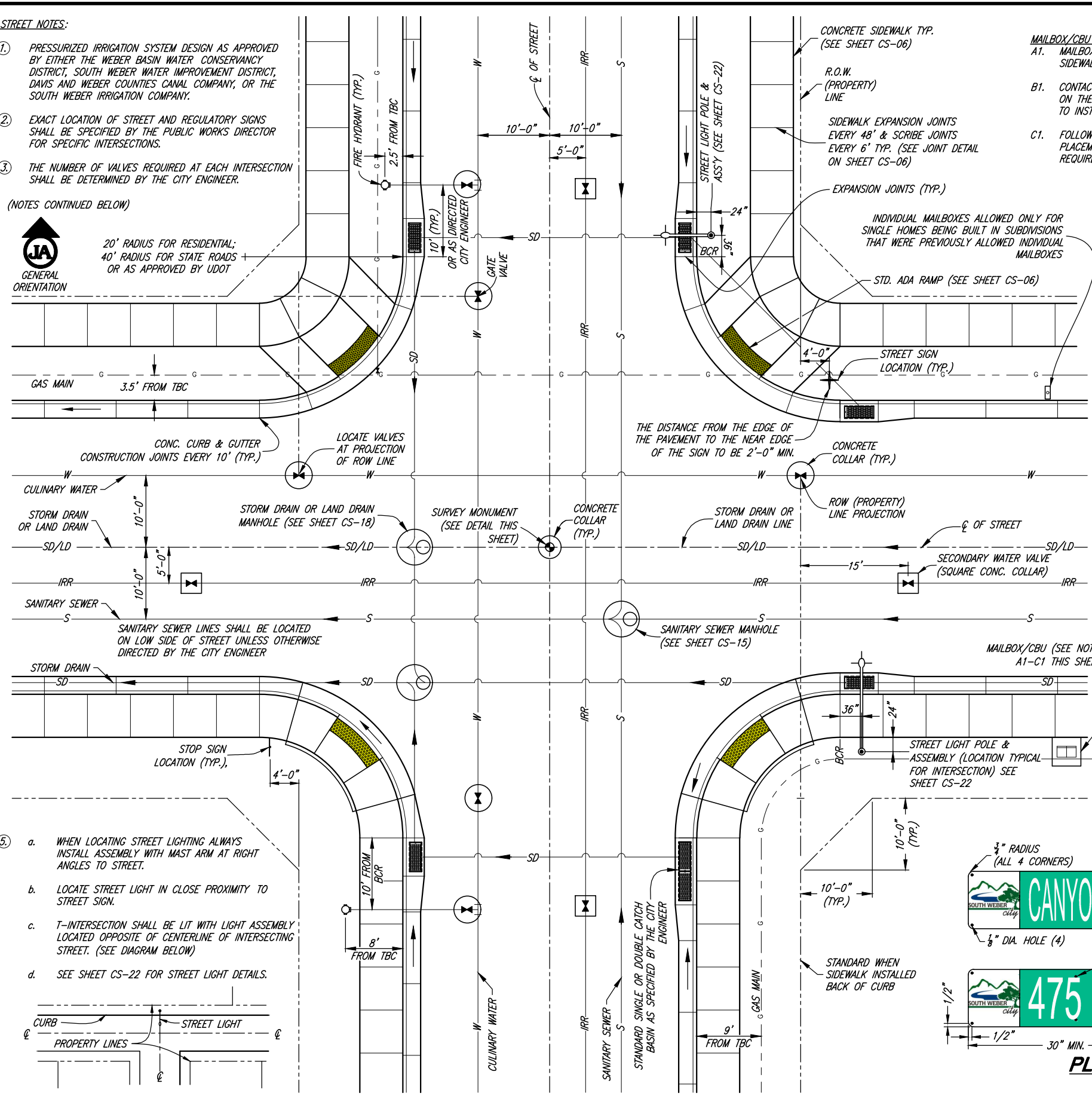
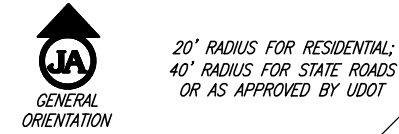

MAILBOX/CBU NOTES:

- MAILBOXES SHALL NOT BE PLACED IN THE SIDEWALK.
- CONTACT THE LOCAL POSTMASTER FOR APPROVAL ON THE LOCATION OF THE MAILBOX OR CBU PRIOR TO INSTALLATION.
- FOLLOW USPS GUIDELINES & POLICIES FOR THE PLACEMENT, INSTALLATION, AND ACCESS REQUIREMENTS FOR ALL MAILBOX AND CBU UNITS.

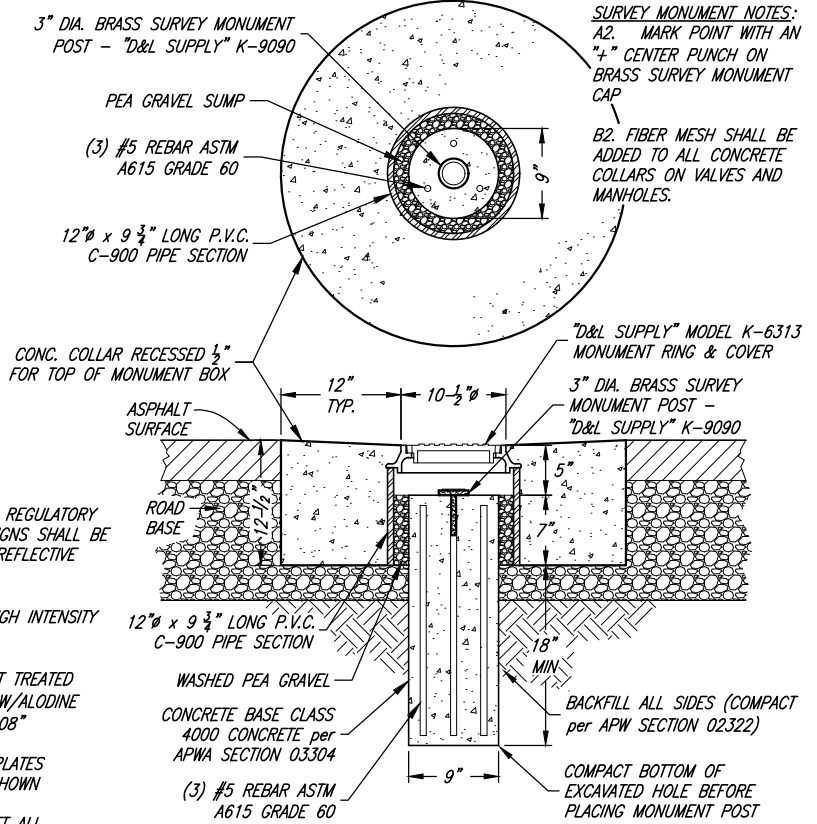

SURVEY MONUMENT NOTES:
 A2. MARK POINT WITH AN "A" CENTER PUNCH ON BRASS SURVEY MONUMENT CAP
 B2. FIBER MESH SHALL BE ADDED TO ALL CONCRETE COLLARS ON VALVES AND MANHOLES.

SURVEY MONUMENT DETAIL

STREET SIGN NOTES:

- STREET SIGN BACKGROUND SHALL BE REGULATORY GREEN, BOTH STREET AND TRAFFIC SIGNS SHALL BE AT THE VERY LEAST HIGH INTENSITY REFLECTIVE SHEETING (9FP-85 TYPE IIIA)
- LEGEND SHALL BE WHITE LETTERS, HIGH INTENSITY REFLECTIVE SHEETING (9FP-85 IIIA)
- SIGN BLANK SHALL BE 6081-T6 HEAT TREATED HIGH TENSILE DEGREASED ALUMINUM W/ALODINE 1200 FINISH-THICKNESS SHALL BE 0.08"
- EACH SIGN SHALL CONSIST OF TWO PLATES RIVETED TOGETHER & MOUNTED AS SHOWN
- SIGNS ON PRIVATE ROADS SHALL MEET ALL SPECIFICATIONS FOR STANDARD SIGNS, EXCEPT BACKGROUND SHALL BE BLUE.
- ALL STREETS WITH NAMES MUST ALSO SHOW LOCATIONS COORDINATE DESIGNATION
- CONTACT CITY PRIOR TO MAKING SIGNS TO VERIFY PROPER NAMES AND COORDINATES

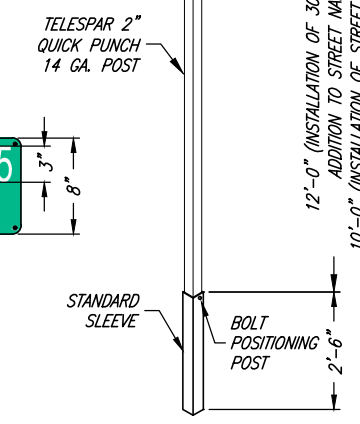
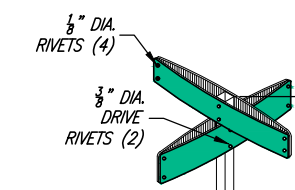

STREET SIGN & POST

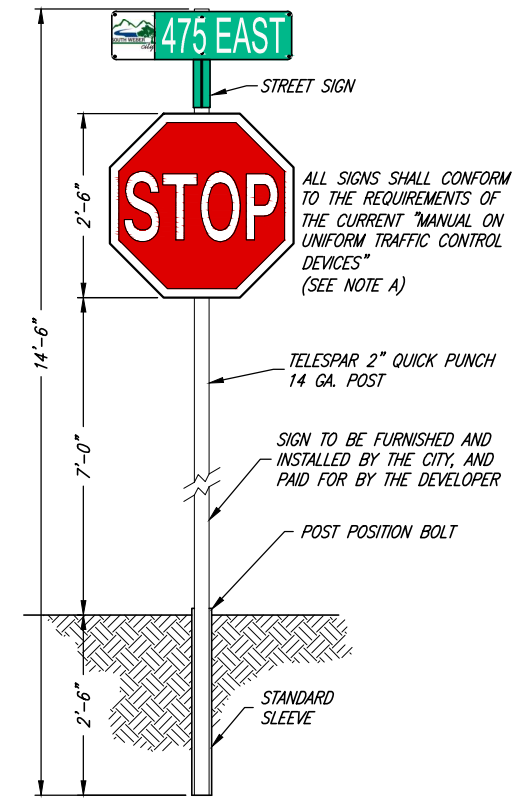

STREET / TRAFFIC SIGN & POST

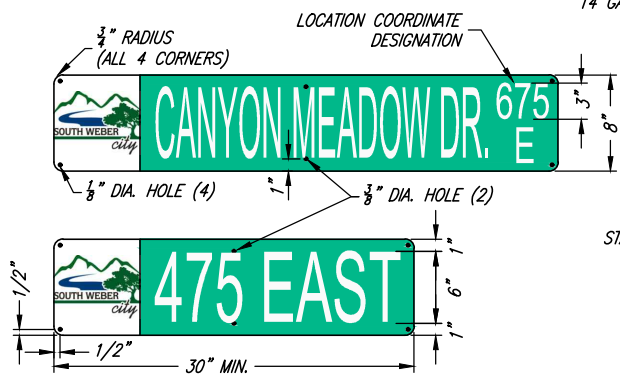
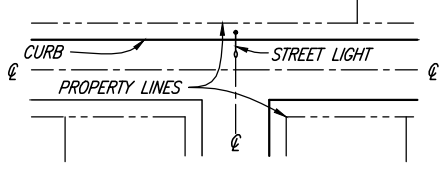

PLATE DETAIL

- WHEN LOCATING STREET LIGHTING ALWAYS INSTALL ASSEMBLY WITH MAST ARM AT RIGHT ANGLES TO STREET.
- LOCATE STREET LIGHT IN CLOSE PROXIMITY TO STREET SIGN.
- T-INTERSECTION SHALL BE LIT WITH LIGHT ASSEMBLY LOCATED OPPOSITE OF CENTERLINE OF INTERSECTING STREET. (SEE DIAGRAM BELOW)
- SEE SHEET CS-22 FOR STREET LIGHT DETAILS.



PROJECT ENGINEER	REV.	DATE	APPR.
DATE			

SCALE:	DESIGNED	BKJ
N. T.S.	DRAWN	BEB
	CHECKED	BKJ

JA JONES & ASSOCIATES CONSULTING ENGINEERS
 6080 Fashion Point Drive
 South Ogden, Utah 84403 (801) 476-9767
 www.jonescivil.com

SOUTH WEBER CITY CORPORATION PUBLIC WORKS STANDARDS
PUBLIC ROADS - TYPICAL INTERSECTION & STREET DETAILS

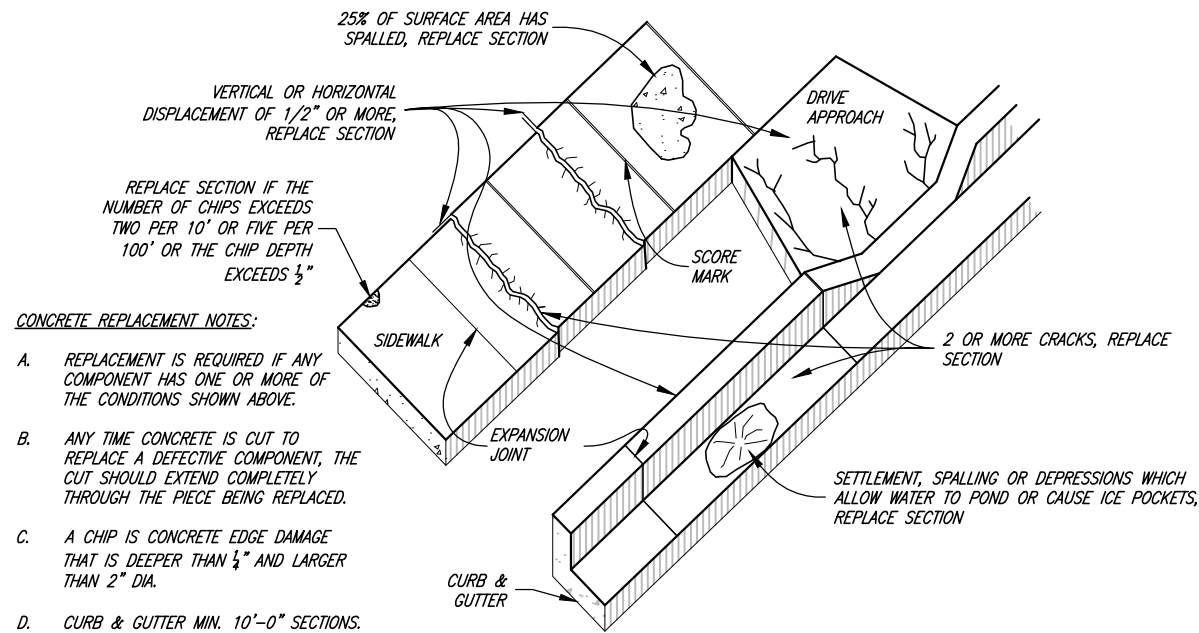

CONCRETE REPLACEMENT NOTES:

- A. REPLACEMENT IS REQUIRED IF ANY COMPONENT HAS ONE OR MORE OF THE CONDITIONS SHOWN ABOVE.
- B. ANY TIME CONCRETE IS CUT TO REPLACE A DEFECTIVE COMPONENT, THE CUT SHOULD EXTEND COMPLETELY THROUGH THE PIECE BEING REPLACED.
- C. A CHIP IS CONCRETE EDGE DAMAGE THAT IS DEEPER THAN 1/4" AND LARGER THAN 2" DIA.
- D. CURB & GUTTER MIN. 10'-0" SECTIONS.

DEFECTIVE CONCRETE REPLACEMENT CRITERIA

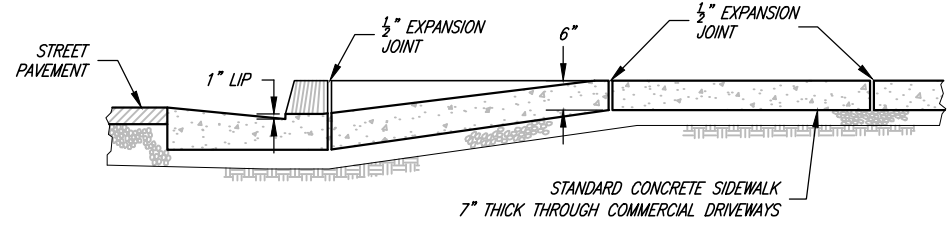
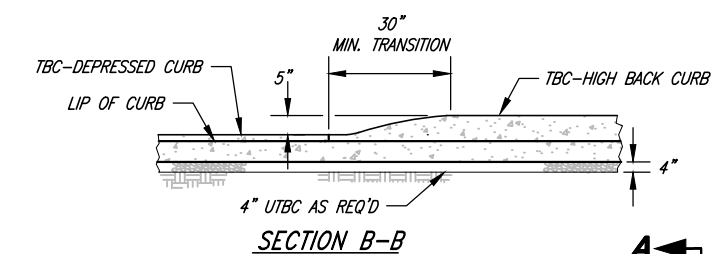

SECTION A-A

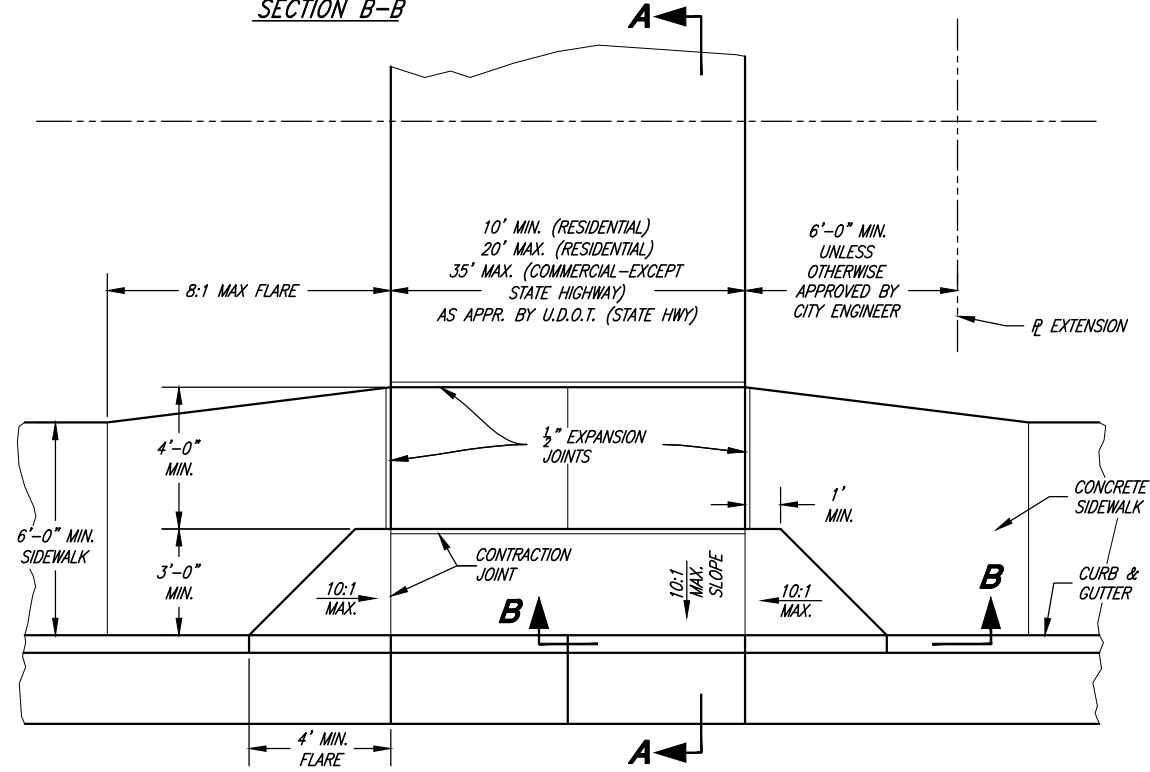

DRIVEWAY APPROACH W/ ADJACENT SIDEWALK

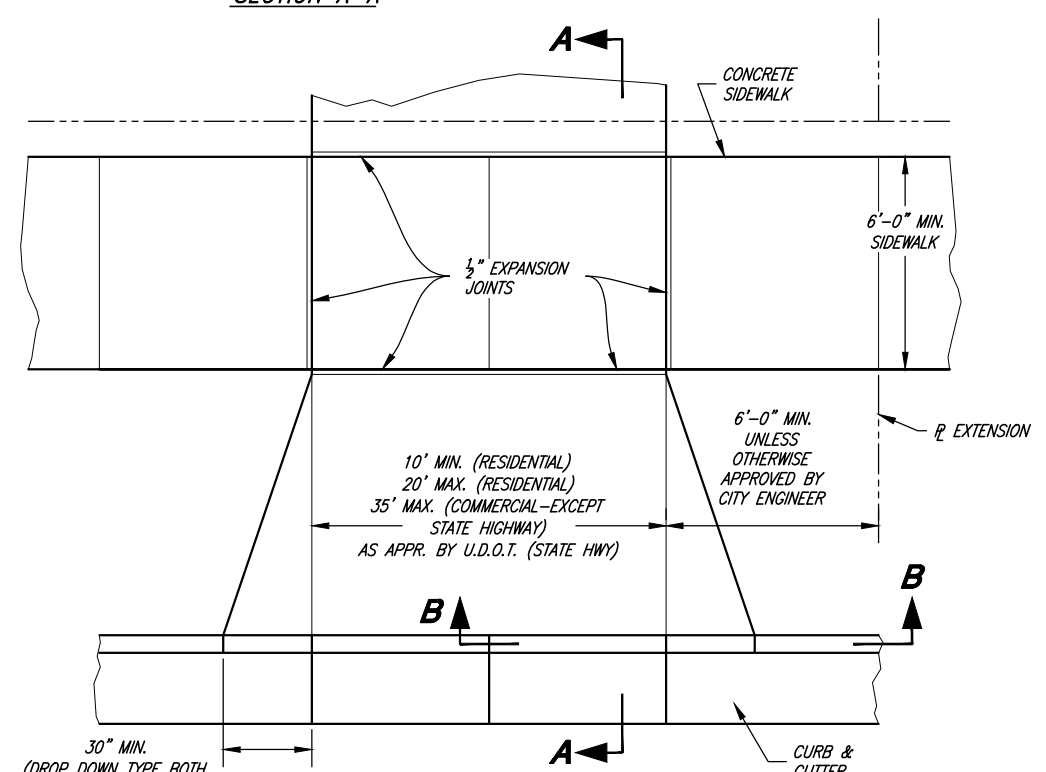

DRIVEWAY APPROACH W/ PARKSTRIP

DROP DOWN STYLE (CITY STANDARD)

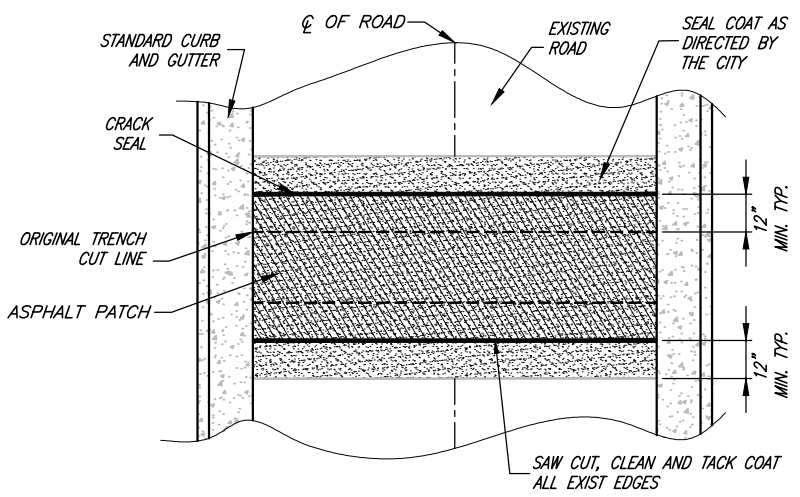

TYPICAL HORIZONTAL ASPHALT PATCH PLAN

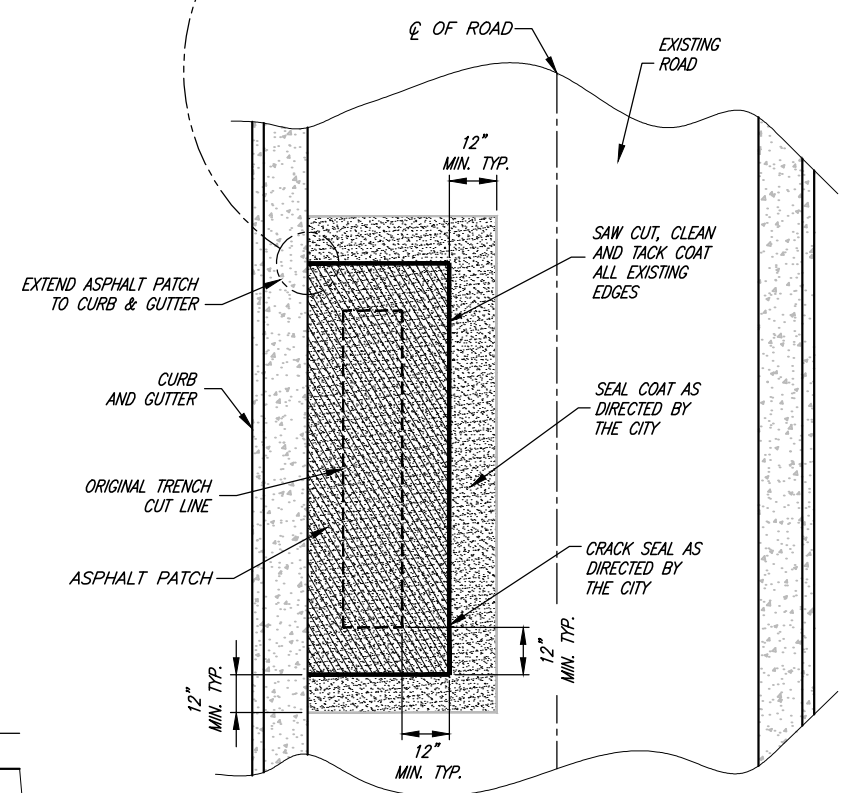
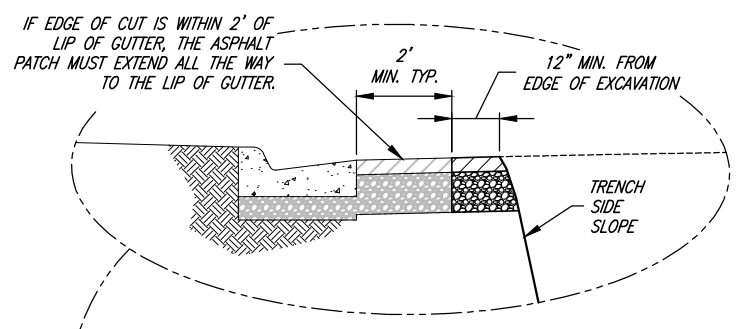

TYPICAL PARALLEL ASPHALT PATCH PLAN

DRIVEWAY APPROACH NOTES:

1. IN NEW SUBDIVISIONS WHERE FUTURE DRIVEWAY LOCATIONS ARE UNKNOWN, THE DRIVEWAY APPROACH SHALL BE MADE BY SAW CUTTING THE BACK OF THE EXISTING CURB TO THE REQUIRED DRIVEWAY WIDTH. ALL SAW CUTTING SHALL BE ACCOMPLISHED BY A CITY APPROVED LICENSED CONTRACTOR.
2. SCORE SIDEWALK 1/4" OF SIDEWALK THICKNESS AT EACH 6'-0" SECTION. EXPANSION JOINTS AT EACH 48'-0", PROVIDE ADDITIONAL CONTRACTION JOINTS ON OVERSIZED DRIVEWAYS AT 5'-0" MAX. SPACING

PROJECT ENGINEER	REV.	DATE	APPR.
DATE			

SCALE:	DESIGNED	BKJ
N. T.S.	DRAWN	BEB
	CHECKED	BKJ

J&A CONSULTING ENGINEERS
 6080 Fashion Point Drive
 South Ogden, Utah 84403 (801) 476-9767
 www.jonescivil.com

SOUTH WEBER CITY CORPORATION
PUBLIC WORKS STANDARDS
PUBLIC ROADS - TYPICAL DRIVE APPROACH, ASPHALT PATCH & DEFECTIVE CONCRETE REPLACEMENT DETAILS

DETECTABLE WARNING SURFACE NOTES:

- LOCATE THE DETECTABLE WARNING SURFACE SO THE OUTSIDE CORNER NEAREST THE STREET IS WITHIN 1 INCH OF THE BACK OF CURB (TBC). PROVIDE 2'-FOOT MINIMUM DEPTH.
- PROVIDE DETECTABLE WARNING SURFACE FOR FULL WIDTH OF CURB CUT.
- THE DETECTABLE WARNING SURFACE DOMES SHALL BE ORIENTED SUCH THAT THE ROWS ARE PARALLEL WITH THE DIRECTION OF PEDESTRIAN TRAVEL TO THE RAMP ON THE OPPOSITE SIDE OF THE STREET.
- THE STANDARD COLOR FOR THE DETECTABLE WARNING SURFACE SHALL BE YELLOW OR PRE-APPROVED CONTRASTING COLOR. WHEN THE EXISTING SIDEWALK COLOR IS NOT STANDARD CONCRETE, THE COLOR OF THE DETECTABLE WARNING SURFACE SHALL BE DETERMINED BY THE CITY ENGINEER OR AUTHORIZED REPRESENTATIVE.
- WHEN A DETECTABLE WARNING SURFACE DOME IS CUT, THE REMAINING PORTION OF THE DOME SHALL BE BEVELED TO A MAXIMUM SLOPE OF 1:2.

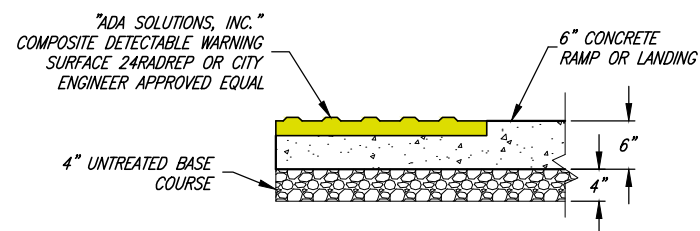

DETECTABLE WARNING SURFACE DETAIL

ADA RAMP NOTES:

- WHERE DESIGNATED BY THE CITY, ALTERNATE UDOT OR APWA RAMP DESIGNS MAY BE USED WITH THE PRIOR APPROVAL OF THE CITY ENGINEER AND THE CITY PUBLIC WORKS DEPARTMENT. SUBMIT ENGINEERED CONSTRUCTION PLANS TO CITY ENGINEER FOR REVIEW AND ACCEPTANCE PRIOR TO CONSTRUCTION.
- SITE CONDITIONS WILL VARY. CONFIGURATION OF RAMP, LANDING, AND TRANSITION MAY BE CHANGED, BUT THEY MUST MEET DIMENSIONS AND SLOPES AS SHOWN IN THE MOST RECENT EDITION OF THE U.D.O.T. STANDARDS & SPECIFICATIONS (SHEETS PA1 THROUGH PA5). THE USE OF FLARES, CURB WALLS, ETC. ARE AT THE DISCRETION OF THE ENGINEER.
- LOCATE CURB CUT WITHIN CROSSWALK.
- RAMP GRADE BREAK MUST BE PERPENDICULAR TO THE RUNNING SLOPE.

SLOPE TABLE			
	ITEM	MAX RUNNING SLOPE*	MAX. CROSS SLOPE*
(T)	TURNING SPACE ²	2% (1V:48H)	2% (1V:48H)
(R)	RAMP	8.3% (1V:12H)	2% (1V:48H)
(S)	SIDEWALK	5% (1:20) ¹	2% (1V:48H)
(F1)	TRAVERSABLE SURFACE	10% (1V:10H)	--
(F2)	NON-TRAVERSABLE SURFACE	25% (1V:4H)	--
(B)	BLENDED TRANSITION	5% (1V:20H) 2% MIN.	2% (1V:48H)

* RUNNING SLOPE IS IN THE DIRECTION OF PEDESTRIAN TRAVEL. CROSS SLOPE IS PERPENDICULAR TO PEDESTRIAN TRAVEL.

¹ 5% MAX OR NATURAL SLOPE OF LAND

² NOT TO EXCEED 2% IN ANY DIRECTION

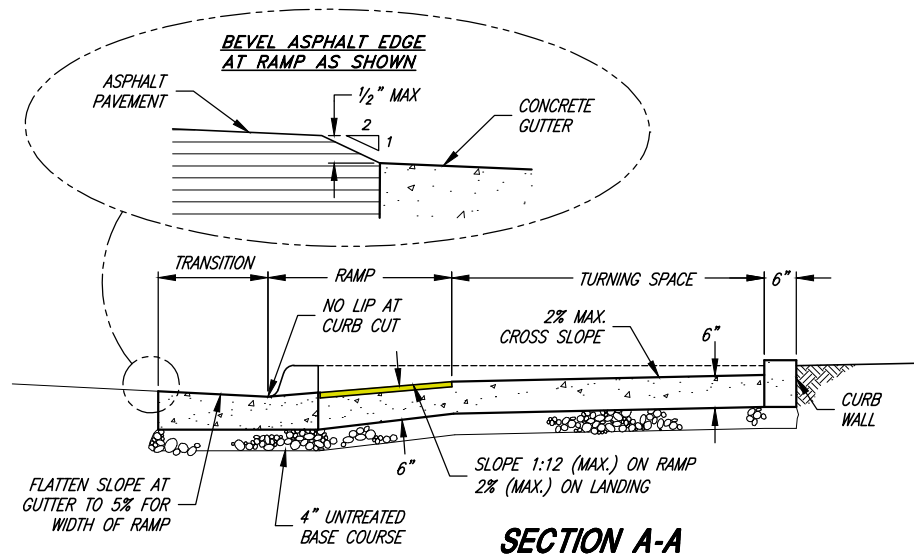

SECTION A-A

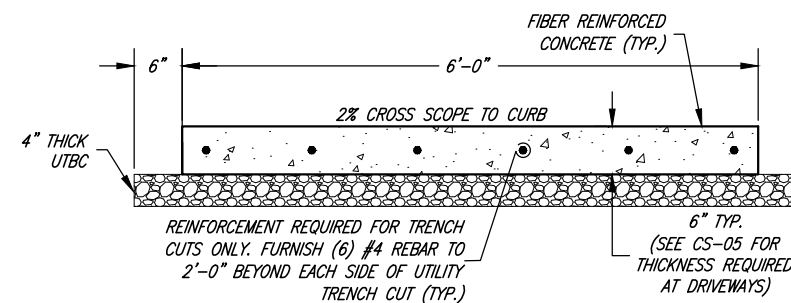

SIDEWALK SECTION
(CITY STANDARD)

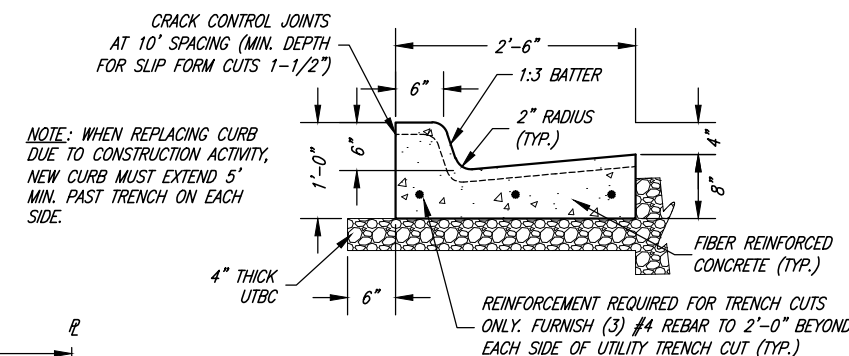

CURB & GUTTER SECTION
(CITY STANDARD)

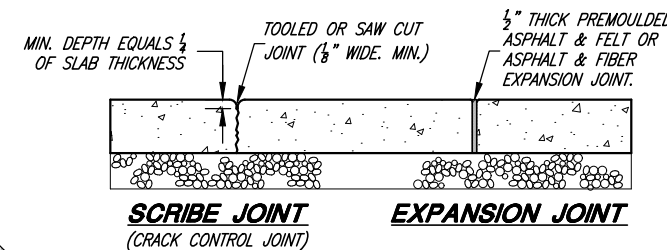

JOINT DETAIL

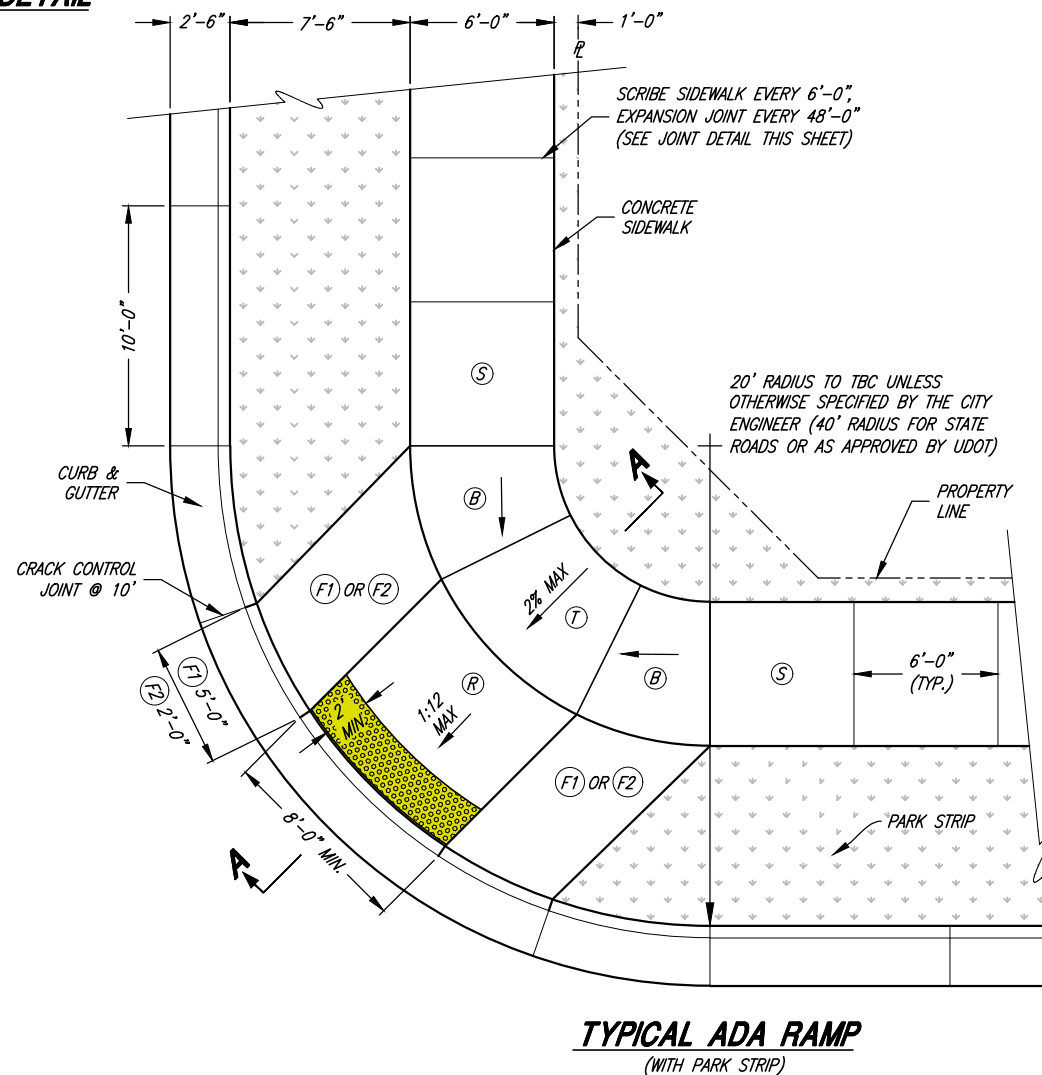

TYPICAL ADA RAMP
(WITH PARK STRIP)

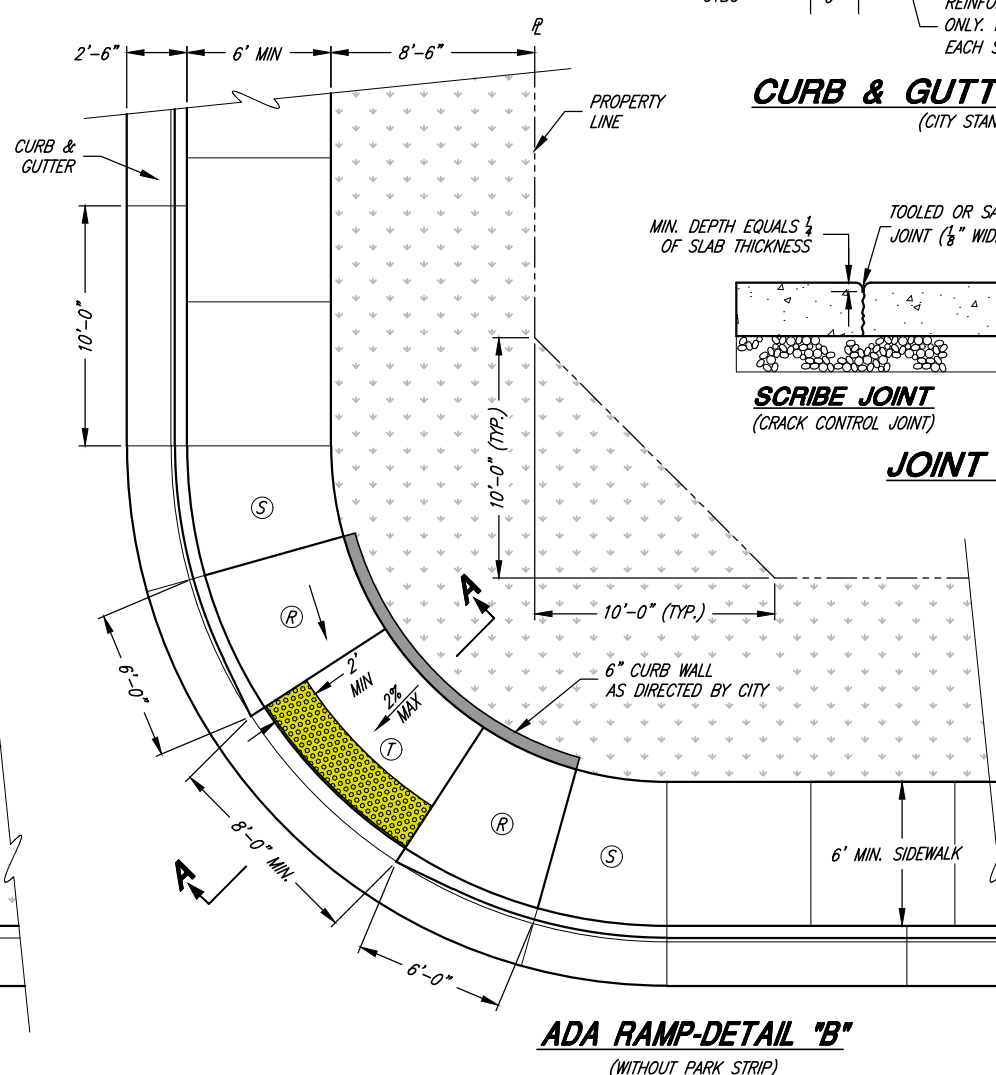

ADA RAMP-DETAIL "B"
(WITHOUT PARK STRIP)

PROJECT ENGINEER	REV.	DATE	APPR.
DATE			

SCALE:

N. T.S.

DESIGNED BKJ
DRAWN BEB
CHECKED BKJ



CONSULTING ENGINEERS
6080 Fashion Point Drive
South Ogden, Utah 84403 (801) 476-9767
www.jonescivil.com

SOUTH WEBER CITY CORPORATION
PUBLIC WORKS STANDARDS
PUBLIC ROADS - TYPICAL ADA RAMP, SIDEWALK, CURB & GUTTER, AND CONCRETE JOINT DETAILS

SHEET:
CS-06
OF 23 SHEETS
0

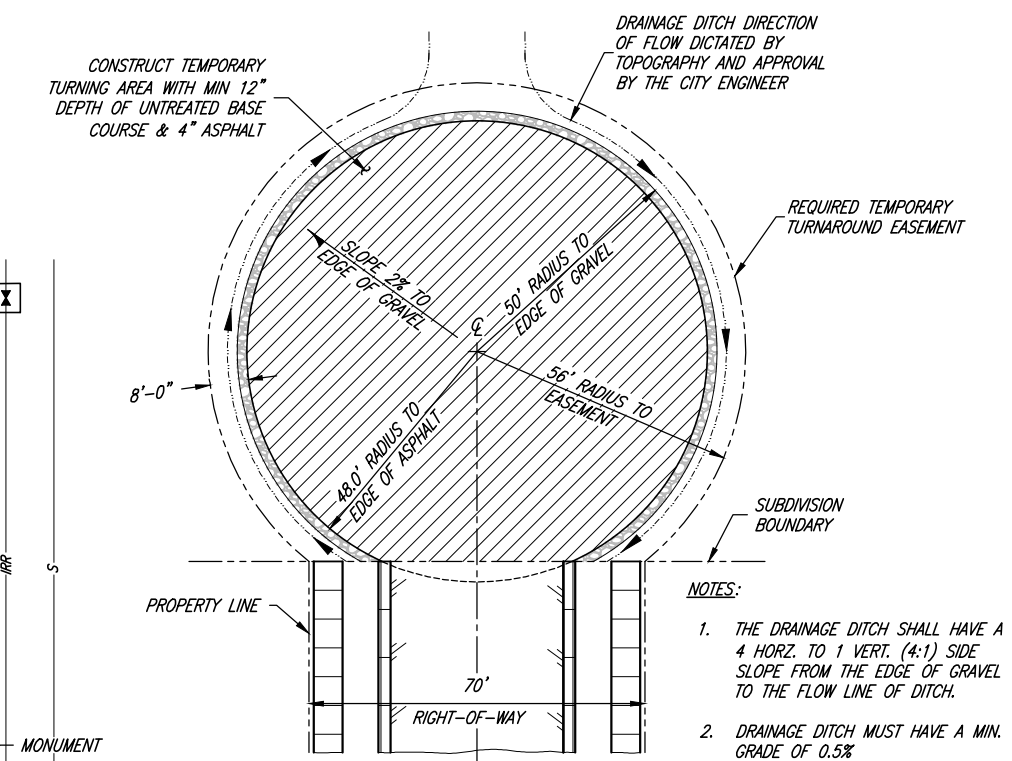
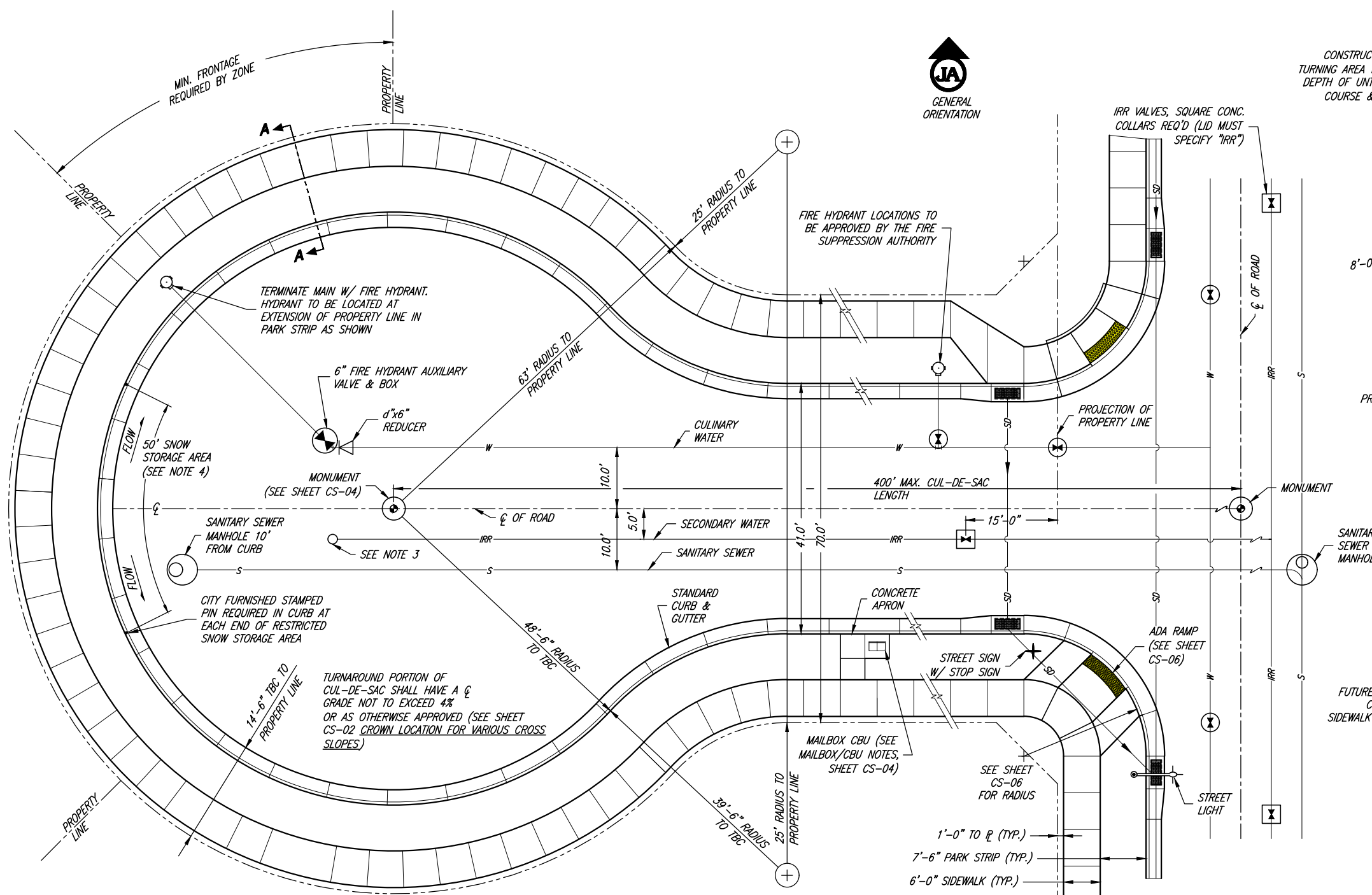

**CITY STANDARD
TEMPORARY TURNAROUND**
(FOR OUTSIDE OF SUBDIVISION BOUNDARY AND TO BE MAINTAINED BY PROPERTY OR EASEMENT OWNER)

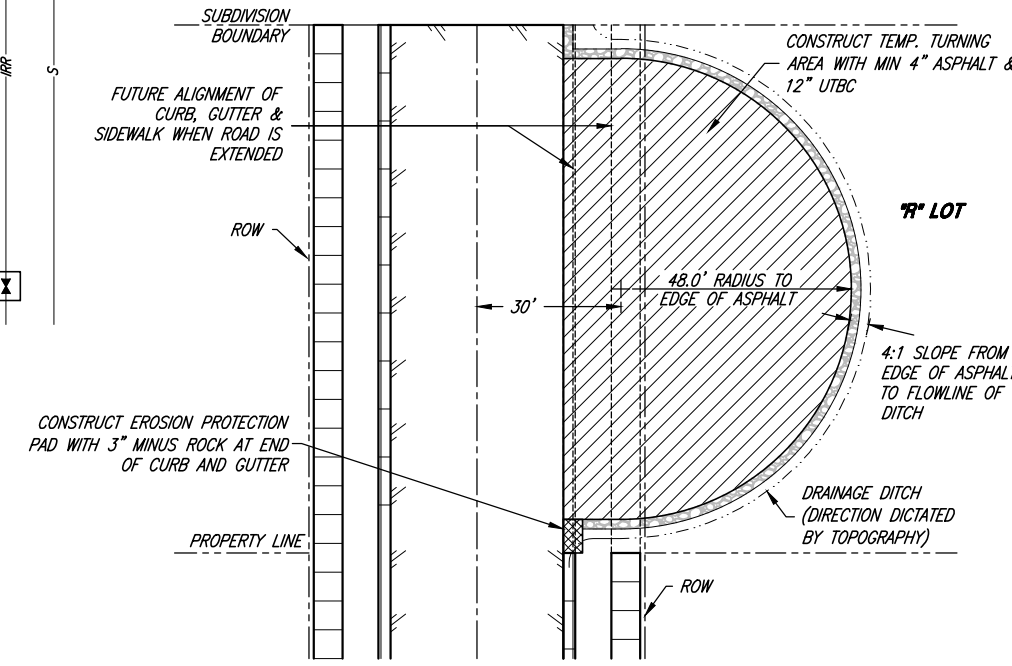

TEMPORARY TURNAROUND
(FOR INSIDE SUBDIVISION BOUNDARY TO BE MAINTAINED BY PROPERTY OWNER)

CUL-DE-SAC
70' RIGHT-OF-WAY

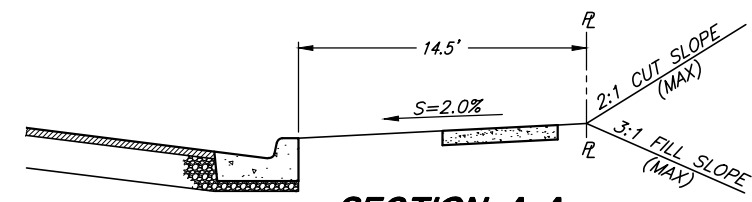

SECTION A-A
REQUIRED GRADING BETWEEN TBC AND PROPERTY LINE

- GENERAL NOTES:**
1. THE CIRCULAR CUL-DE-SAC LAYOUT ON THIS SHEET IS TO BE CONSIDERED AS THE CITY STANDARD DESIGN. OTHER ALTERNATE DESIGNS MAY BE CONSIDERED AS APPROVED BY THE CITY ENGINEER.
 2. MODIFIED CUL-DE-SACS (KNUCKLE, EYEBROW, BULB, OR HALF CUL-DE-SACS) ARE NOT PERMITTED.
 3. DEVELOPER SHALL PROVIDE AN AIR RELIEF OR BLOW-OFF AS DETERMINED BY THE SECONDARY WATER PROVIDER AND IN ACCORDANCE WITH THEIR STANDARDS AND APPROVED BY THE CITY ENGINEER.
 4. NO DRIVEWAYS, FIRE HYDRANTS, OR MAIL BOXES ARE PERMITTED WITHIN THE 50' SNOW STORAGE AREA.

PROJECT ENGINEER			
DATE	REV.	DATE	APPR.

SCALE:
N. T. S.

DESIGNED BKJ
DRAWN BEB
CHECKED BKJ



CONSULTING ENGINEERS
6080 Fashion Point Drive
South Ogden, Utah 84403 (801) 476-9767
www.jonescivil.com

SOUTH WEBER CITY CORPORATION
PUBLIC WORKS STANDARDS
PUBLIC ROADS - CUL-DE-SAC & TEMP. TURNAROUND DETAILS

SHEET:
CS-07
OF 23 SHEETS
0

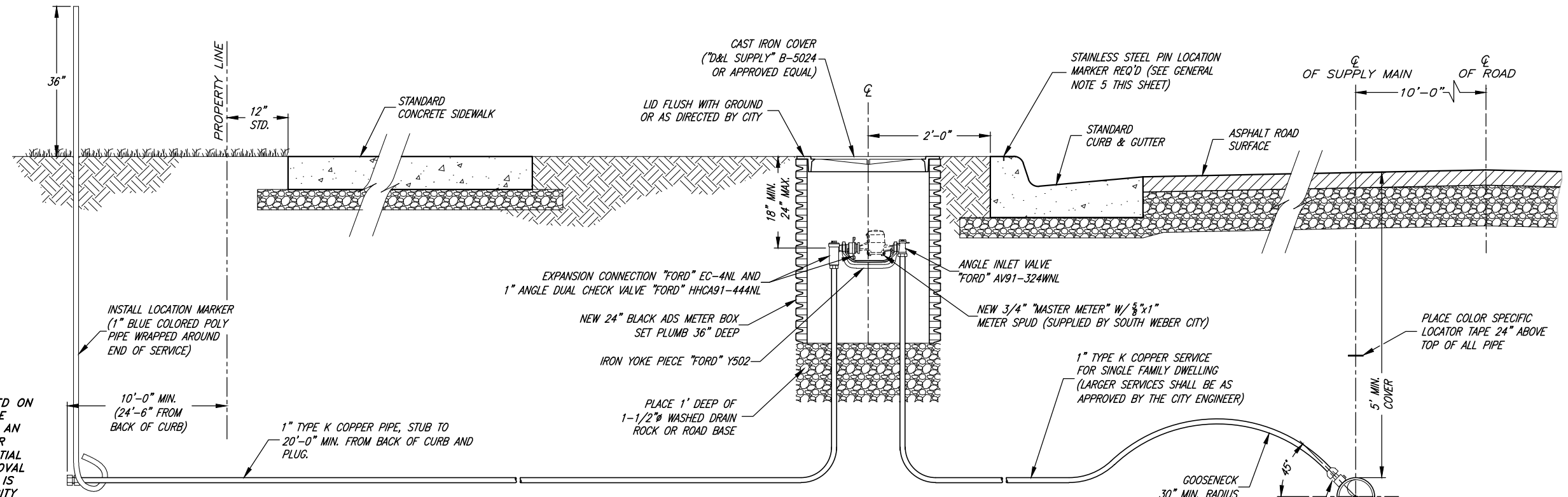

RESIDENTIAL WATER SERVICE AND METER
CITY STANDARD

METER LOCATION NOTE:
**ALL CULINARY WATER METERS SHALL BE CENTERED ON THE LOT AND SHOULD NOT BE LOCATED WITHIN THE DRIVEWAY AREA. IF A DRIVEWAY IS PLACED OVER AN EXISTING METER, THE "ENTIRE" SERVICE AND METER SHALL BE RELOCATED OR A HIGH TRAFFIC RESIDENTIAL METER PIT MAY BE INSTALLED WITH WRITTEN APPROVAL FROM THE WATER SYSTEM SUPERINTENDENT. THIS IS DETERMINED ON A CASE BY CASE BASIS BY THE CITY WATER SYSTEM SUPERINTENDENT AND TO BE PAID FOR BY THE OWNER.

DUCTILE IRON PIPE:
POLYWRAP ALL D.I.P. WATERLINES
8"-12" MAINS SHALL BE CLASS 51.
14" OR LARGER MAINS SHALL BE CLASS 250 psi

- GENERAL NOTES:**
1. ALL FITTINGS SHALL BE "MUELLER" COMPRESSION TYPE UNLESS OTHERWISE NOTED.
 2. "BLUE" BOLTS AND NUTS ARE REQUIRED BY THE CITY.
 3. ALL SUPPLIES, LABOR, MACHINERY, ETC. WILL BE SUPPLIED BY THE CONTRACTOR. SOUTH WEBER CITY WILL SUPPLY AND SET THE METER ONLY ON 1" CONNECTIONS. THE CONTRACTOR SHALL SUPPLY METERS FOR CONNECTIONS GREATER THAN 1" (SEE SHEET CS-11).
 4. ALL SPECIFIED BRANDS OF MATERIALS SHOWN ON THESE DRAWINGS ARE "CITY STANDARDS." OTHER EQUIVALENT BRANDS MAY BE USED WITH THE PRIOR APPROVAL OF THE CITY ENGINEER AND THE CITY WATER SYSTEM SUPERINTENDENT.
 5. STAMPED STAINLESS STEEL PINS USED FOR LATERAL LOCATING ARE REQUIRED BY THE CITY. BLANK S.S. PINS SHALL BE PROVIDED BY THE CITY AND INSTALLED AND STAMPED BY THE CONTRACTOR DURING ALL NEW CONSTRUCTION OR RESTORED WHEN REPLACING DAMAGED CURB & GUTTER DUE TO ANY CONSTRUCTION RELATED ACTIVITY. S.S. PINS SHALL BE STAMPED "S" FOR SANITARY SEWER, "W" FOR CULINARY WATER, AND "L" FOR LAND DRAIN.

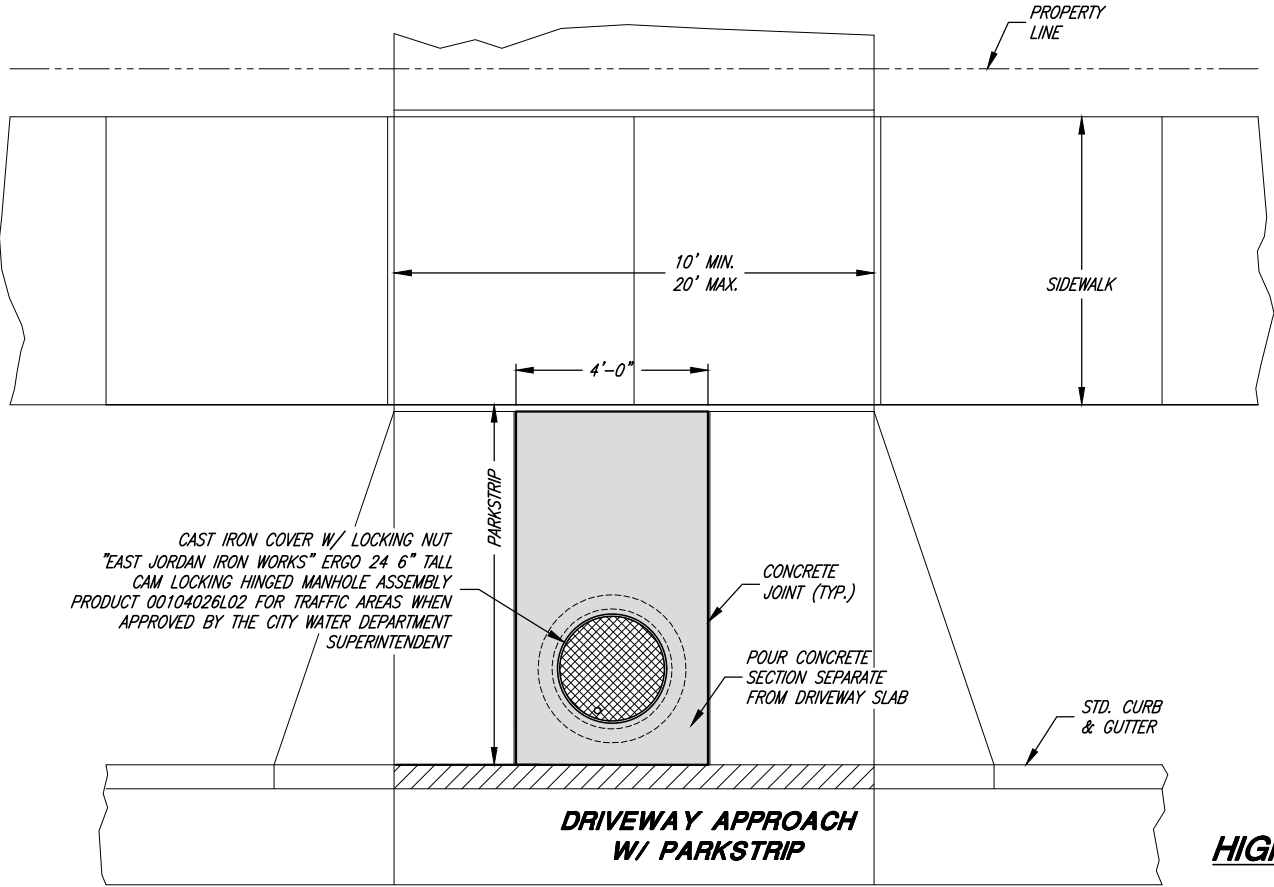

HIGH TRAFFIC RESIDENTIAL METER PIT DETAIL

THE USE OF A HIGH TRAFFIC RESIDENTIAL SERVICE METER PIT IS SITE SPECIFIC AND REQUIRES WRITTEN APPROVAL FROM THE WATER SYSTEM SUPERINTENDENT PRIOR TO INSTALLATION

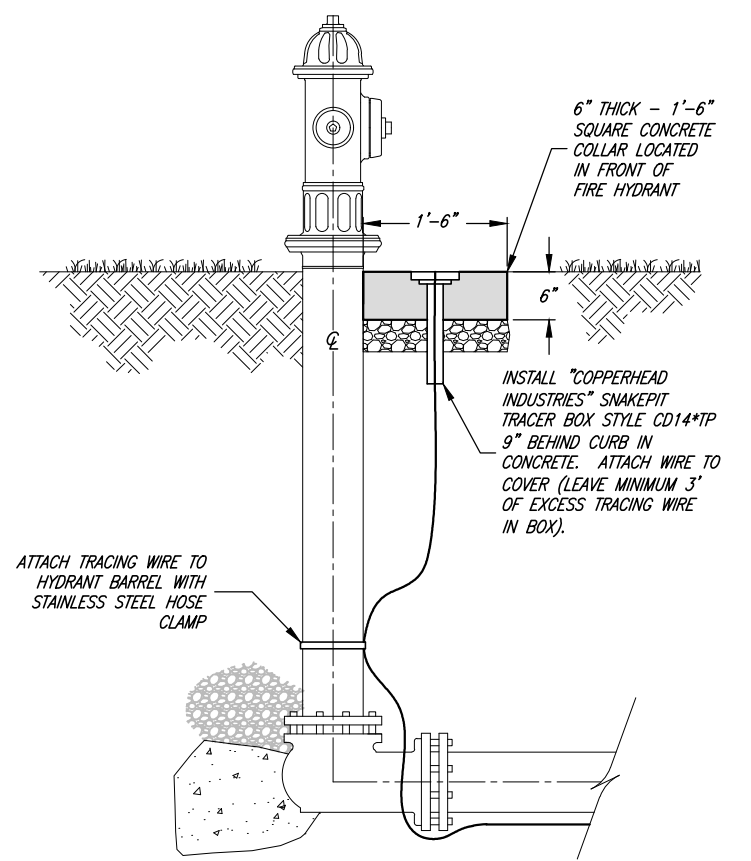
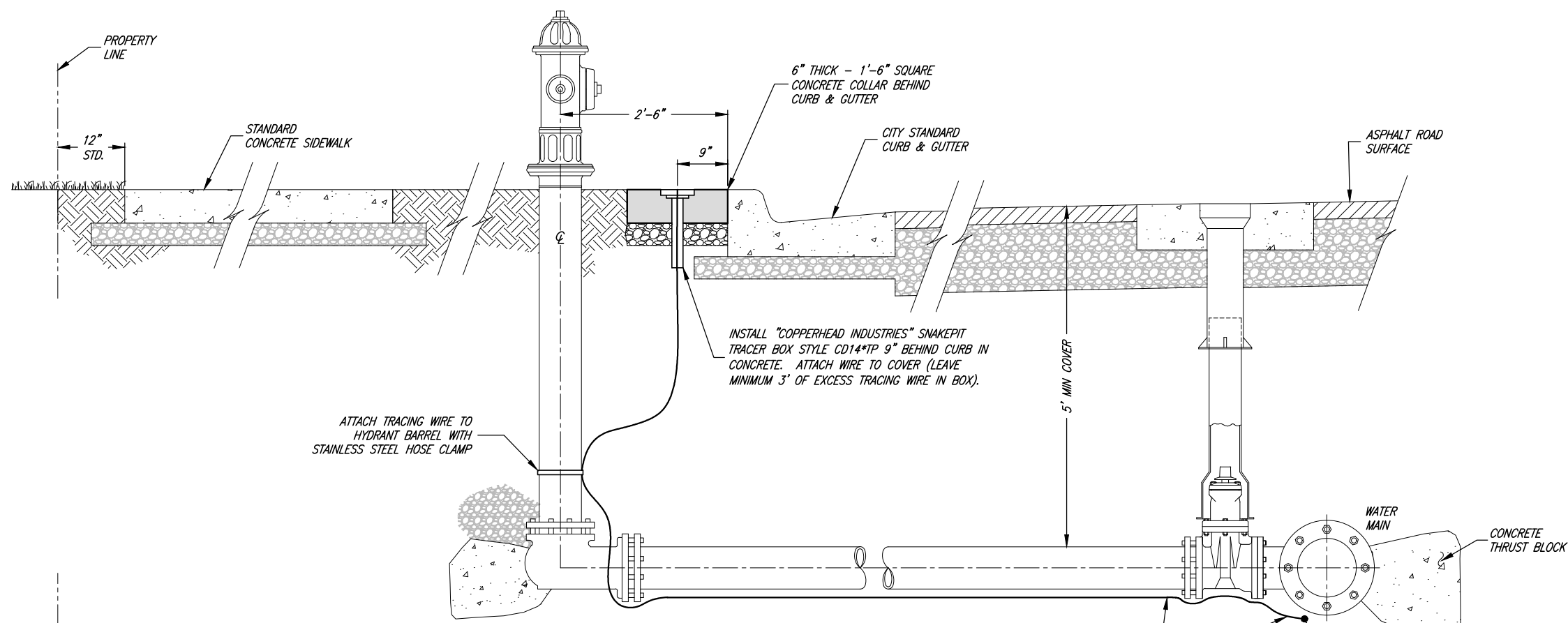

ALTERNATE TRACER WIRE INSTALLATION

WHERE APPROVED BY THE WATER SYSTEM SUPERINTENDENT ON STREET SECTIONS WITH NO CURB & GUTTER

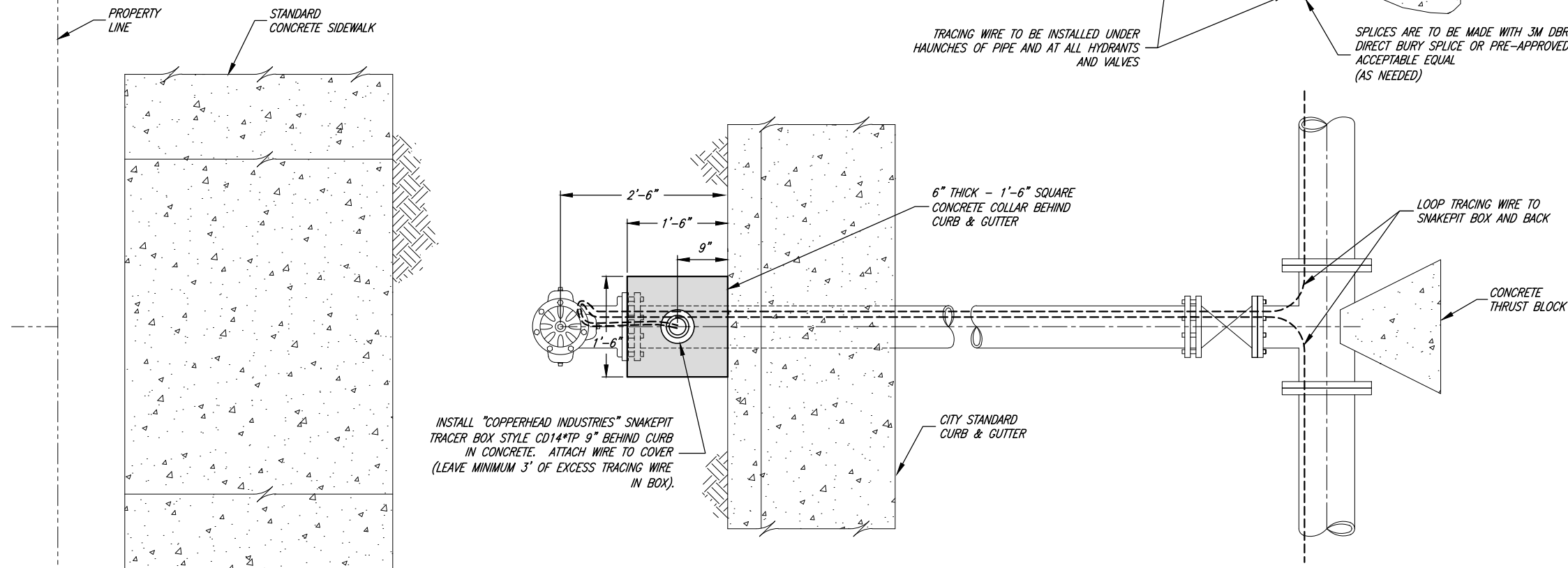

TRACER WIRE INSTALLATION
CITY STANDARD STREET SECTION (CURB & GUTTER)

NOTES:

1. ALL WATERLINES SHALL HAVE A MINIMUM 12 GA. INSULATED TRACING WIRE INSTALLED UNDER THE HAUNCHES OF THE PIPE PRIOR TO BACKFILLING.
2. TRACING WIRES SHALL TERMINATE AT ALL FIRE HYDRANTS. AT SERVICE SADDLES AND TAPPING SLEEVES, THE TRACING WIRE SHALL NOT BE ALLOWED TO BE PLACED BETWEEN THE SADDLE AND THE PIPE. A GROUNDING ROD SHALL BE INSTALLED AT ALL TRACER SYSTEM TERMINAL POINTS.
3. TRACING WIRE SHALL BE COPPER WIRE WITH BLUE INSULATION RATED FOR DIRECT BURIAL. ALL WIRE CONNECTORS SHALL BE 3M DBR DIRECT BURY SPLICE OR PRE-APPROVED ACCEPTABLE EQUAL AND SHALL BE WATERTIGHT TO PROVIDE ELECTRICAL CONTINUITY.
4. ALL TRACING WIRE SHALL BE TESTED FOR CONTINUITY IN THE PRESENCE OF THE PUBLIC WORKS INSPECTOR PRIOR TO ASPHALT PLACEMENT. ANY TRACING WIRE FOUND NOT TO BE CONTINUOUS AFTER TESTING SHALL BE REPAIRED OR REPLACED BY THE CONTRACTOR PRIOR TO ASPHALT PLACEMENT.

PROJECT ENGINEER			
DATE	REV.	DATE	APPR.

SCALE:
N. T.S.

DESIGNED BKJ
DRAWN BEB
CHECKED BKJ

JA JONES & ASSOCIATES CONSULTING ENGINEERS
6080 Fashion Point Drive
South Ogden, Utah 84403 (801) 476-9767
www.jonescivil.com

SOUTH WEBER CITY CORPORATION
PUBLIC WORKS STANDARDS
CULINARY WATER - TRACING WIRE
INSTALLATION DETAILS

SHEET:
CS-10
OF 23 SHEETS
0

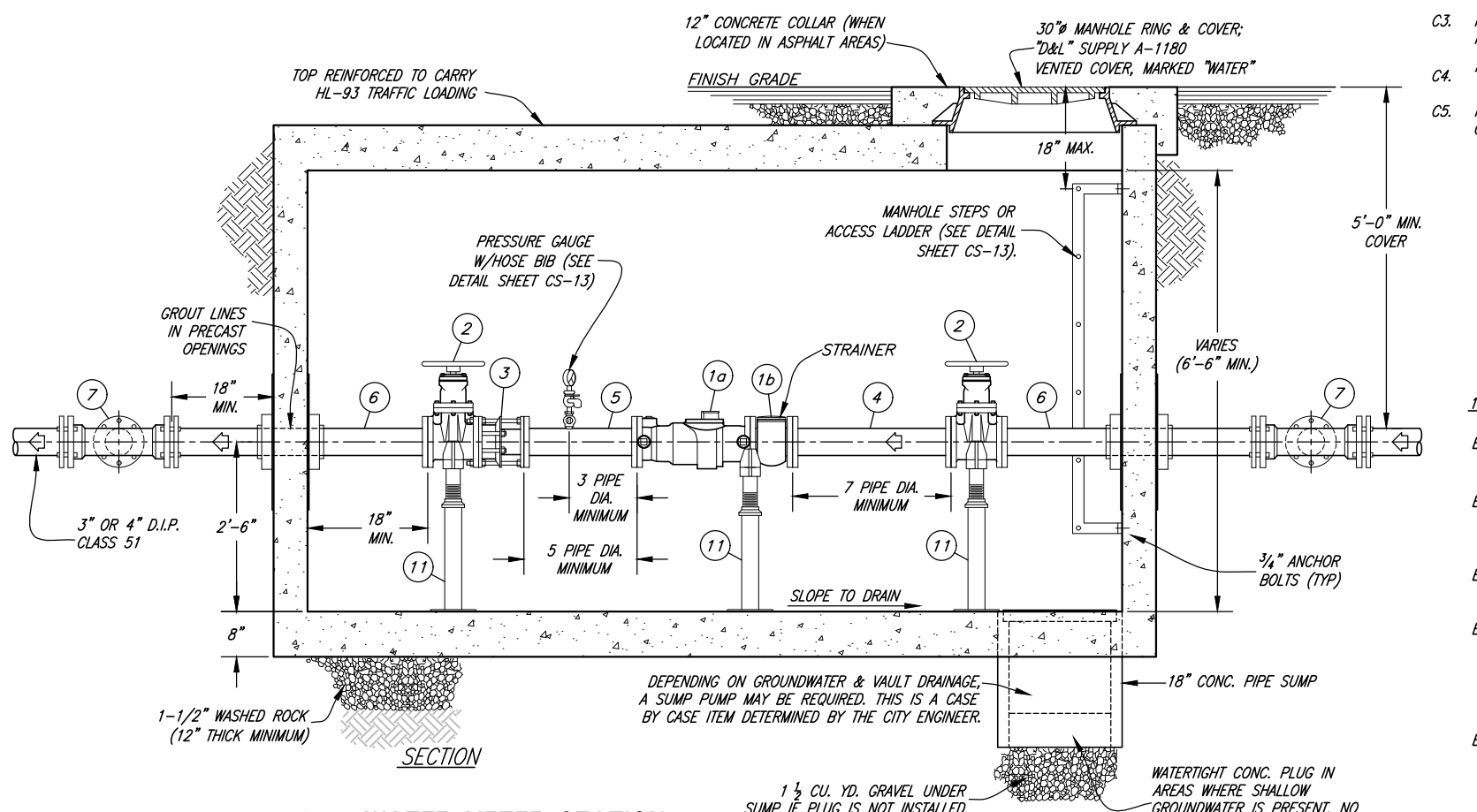
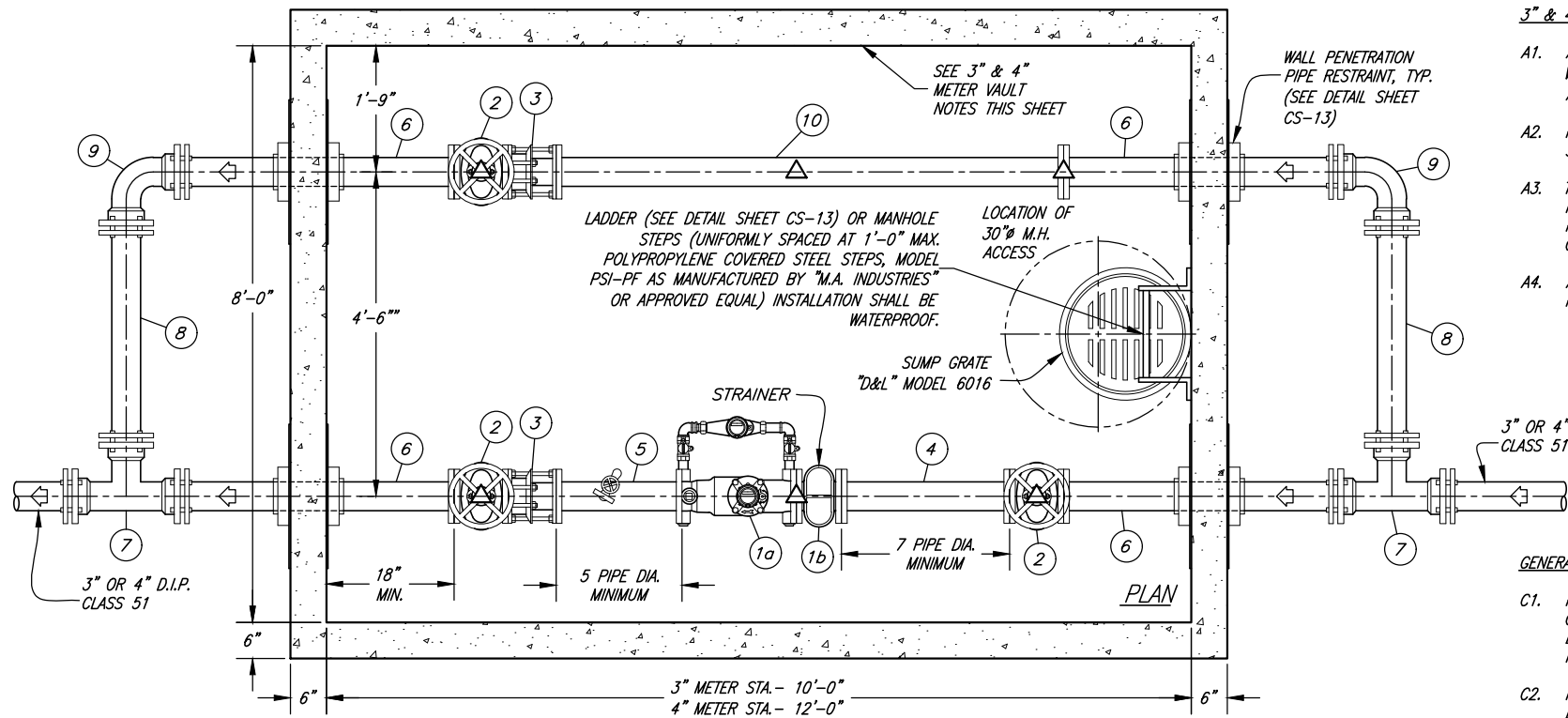

3" & 4" WATER METER STATION

- 3" & 4" METER VAULT NOTES:**
- A1. ALL FITTINGS OUTSIDE OF THE VAULT ARE TO BE DUCTILE IRON MJ WITH THRUST RESTRAINT RETAINER GLANDS ("ROMAC", MJRG, OR APPROVED EQUAL)
 - A2. PENETRATION WALLS NEED TO BE ADEQUATELY DESIGNED STRUCTURALLY FOR ANTICIPATED THRUST.
 - A3. THE PRECAST VAULT MANUFACTURER IS RESPONSIBLE FOR DESIGN RELATED TO TRAFFIC LOADING AND THRUST. VERIFICATION OF PROPER DESIGN MUST BE PROVIDED TO THE CITY BY THE DEVELOPER, CONTRACTOR, OR PROPERTY OWNER AS THE CASE MAY BE.
 - A4. ALL FITTINGS SHALL BE AWWA C-110 WITH 125 LB. FLANGES. ALL PIPING SHALL BE DUCTILE IRON PIPE CLASS 350 P.S.I. MIN.

NOTE: ALL SPECIFIED BRANDS OF MATERIALS SHOWN ON THESE DRAWINGS ARE "CITY STANDARDS." OTHER EQUIVALENT BRANDS MAY BE USED WITH THE PRIOR APPROVAL OF THE CITY ENGINEER AND THE CITY WATER SYSTEM SUPERINTENDENT.

- GENERAL NOTES:**
- C1. PROPERTY OWNER OR CONTRACTOR SHALL PAY FOR ALL COSTS OF INSTALLATION INCLUDING ALL MATERIALS, ALL EXCAVATION AND FILL, ASPHALT REPLACEMENT AND WATER MAIN CONNECTION.
 - C2. INSPECTION OF ALL WATER LINE INSTALLATIONS WILL BE DONE BY THE CITY WATER DEPARTMENT, WITH A 48 HOUR MINIMUM NOTICE REQUIRED PRIOR TO START OF WORK.
 - C3. IF APPLICABLE, A CITY EXCAVATION PERMIT MUST BE REQUESTED AND APPROVED PRIOR TO START OF WORK.
 - C4. "BLUE" BOLTS AND NUTS ARE REQUIRED BY THE CITY.
 - C5. FIBER MESH SHALL BE ADDED TO ALL CONCRETE COLLARS ON VALVES AND MANHOLES.

PIPE & FITTING SCHEDULE

NO.	DESCRIPTION (3" & 4" METER STA.)	JOINT TYPE	LINE	
			3"	4"
1a	MASTER METER™ DUAL BODY COMPOUND (DBC) METER	FL	3"	4"
1b	W/ STRAINER & 3G INTEGRATED REGISTER			
2	"MUELLER" RESILIENT WEDGE GATE VALVE	FL	3"	4"
	W/ HANDWHEEL		A-2362	A-2361
3	"ROMAC" DJ400 DISMANTLING JOINT	FL	3"	4"
4	SPOOL PIECE (7 PIPE DIA. MINIMUM)	FL	3"	4"
5	SPOOL PIECE (5 PIPE DIA. MINIMUM)	FL	3"	4"
6	NIPPLE	FLxPE	3"	4"
7	TEE	MJ	3"	4"
8	PIPE SECTION	PE	3"	4"
9	90° ELBOW	MJ	3"	4"
10	SPOOL PIECE	FL	3"	4"
11	"CLOW" F-1608 OR "ANVIL" #264 GALV. PIPE SUPPORT W/ COMPANION FLANGE & VARIABLE HEIGHT NIPPLE (6 EA REQ'D)			△ SYMBOL

NO.	DESCRIPTION (1 1/2" & 2" METER STA.)	JOINT TYPE	LINE	
			1 1/2"	2"
12	MASTER METER™ INTERMEDIATE MULTI-JET METER	FL	1 1/2"	2"
	W/3G INTEGRATED REGISTER			
13	"MUELLER" B-2423-2 METER YOKE (18" RISER)	-	1 1/2"	2"
14	"MUELLER" 110 COMPRESSION CONN. COUPLING	-	1 1/2"	2"

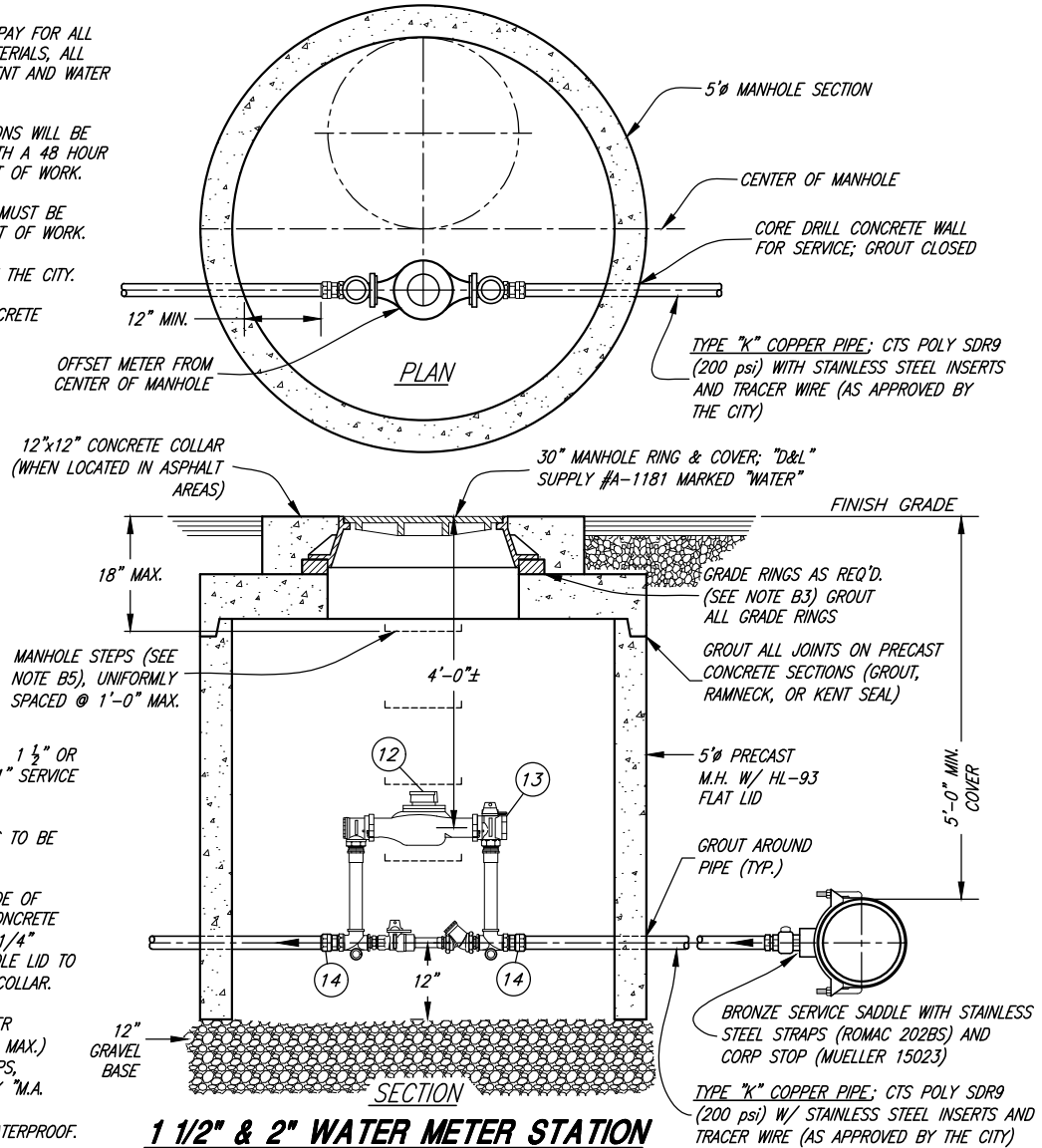

1 1/2" & 2" WATER METER STATION

- 1 1/2" & 2" METER NOTES:**
- B1. 1 1/2" SERVICE LINE-13" METER
2" SERVICE LINE-17" METER
 - B2. CONTRACTOR TO SUPPLY ALL METERS. 1 1/2" OR LARGER, CITY SUPPLIES METERS ON 1" SERVICE LINES.
 - B3. NO MORE THAN 12" OF GRADE RINGS TO BE ALLOWED ON ANY MANHOLE
 - B4. RAISE ALL MANHOLES TO FINISH GRADE OF STREET FOLLOWING PAVING WITH A CONCRETE COLLAR; COLLAR TO BE HELD DOWN 1/4" BELOW TOP OF NEW ASPHALT. MANHOLE LID TO BE HELD DOWN 1/4" BELOW CONC. COLLAR.
 - B5. MANHOLE STEPS (FOR MANHOLES OVER 6" DEEP.) UNIFORMLY SPACED (1'-0" MAX.) POLYPROPYLENE COVERED STEEL STEPS, MODEL PSI-PF AS MANUFACTURED BY "M.A. INDUSTRIES" OR APPROVED EQUAL - INSTALLATION OF STEPS SHALL BE WATERPROOF.

PROJECT ENGINEER			
DATE	REV.	DATE	APPR.

SCALE:	
N. T.S.	
DESIGNED	BKJ
DRAWN	BEB
CHECKED	BKJ

J.A. JONES & ASSOCIATES
CONSULTING ENGINEERS
6080 Fashion Point Drive
South Ogden, Utah 84403 (801) 476-9767
www.jonescivil.com

SOUTH WEBER CITY CORPORATION
PUBLIC WORKS STANDARDS
CULINARY WATER - STANDARD WATER METER STATIONS

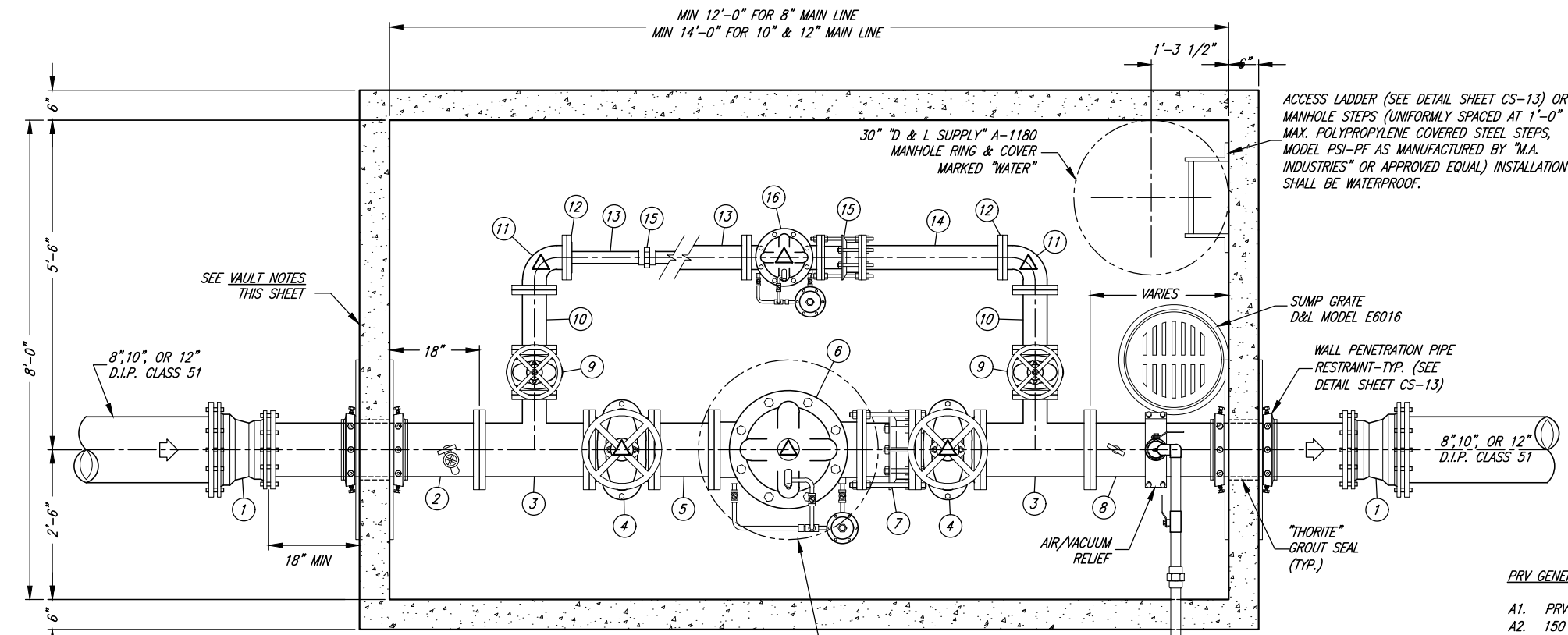

NO.	DESCRIPTION	JOINT TYPE	8" LINE	10" LINE	12" LINE
1	D.I. REDUCER (2)	MJM	8"x6"	10"x8"	12"x10"
2	D.I. NIPPLE PIECE	FLxPE	6"	8"	10"
3	D.I. REDUCING TEE (2)	FL	6"x6"x4"	8"x8"x4"	10"x10"x4"
4	"MUELLER" A-2361 GATE VALVE W/ HANDWHEEL (2)	FL	6"	8"	10"
5	12" D.I. SPOOL PIECE	FL	6"	8"	10"
6	"CLA-VAL" 90-01 PRESSURE REDUCTION VALVE	FL	6"	8"	10"
7	"ROMAC" DJ400 DISMANTLING JOINT	FL	6"	8"	10"
8	D.I. NIPPLE PIECE	FLxPE	6"	8"	10"
9	"MUELLER" A-2361 GATE VALVE W/ HANDWHEEL (2)	FL	4"	4"	4"
10	12" D.I. SPOOL PIECE	FL	4"	4"	4"
11	D.I. 90° ELBOW (2)	FL	4"	4"	4"
12	BLIND FLANGE W/ THR. CONNECTION (2)	FLxTHR.	4"x2"	--	--
13	D.I. SPOOL PIECE BRASS PIPE	THR.	2"	--	--
14	D.I. SPOOL PIECE BRASS PIPE	THR.	2"	--	--
15	"ROMAC" DJ400 DISMANTLING JOINT BRASS UNION	THR.	2"	--	--
16	"CLA-VAL" 90-01 PRESSURE REDUCTION VALVE	THR.	2"	--	--
17	"CLOW" F-1608 OR "ANVIL" #264 GALV. PIPE SUPPORT W/ 3" COMPANION FLANGE & VARIABLE HEIGHT 3" NIPPLE (6 EA REQ'D.)	THR.	--	4"	4"

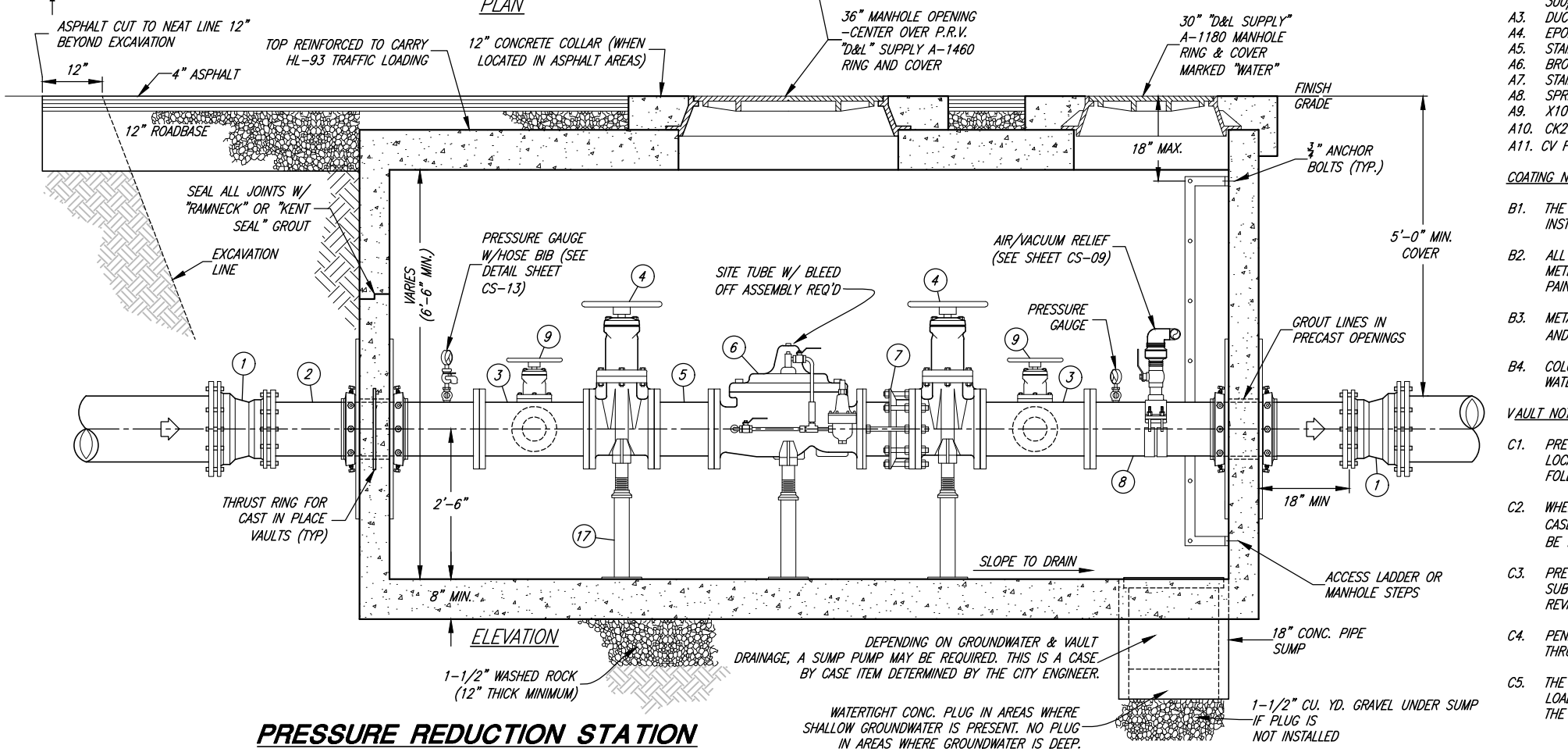

PRV GENERAL SPECIFICATIONS:

- A1. PRV TO BE CLA-VAL #90-01 YBCSKC
- A2. 150 # FLANGED FOR 250 PSI WORKING PRESSURE, 300# FLANGED IF GREATER THAN 250 PSI
- A3. DUCTILE IRON BODY GLOBE PATTERN
- A4. EPOXY LINED AND COATED
- A5. STAINLESS STEEL INTERNAL TRIM
- A6. BRONZE PILOT CONTROLS
- A7. STAINLESS STEEL TUBES & FITTINGS
- A8. SPRING RANGES FOR PRESSURE REDUCING PILOT
- A9. X101 VALVE POSITION INDICATOR
- A10. CK2 ISOLATION BALL VALVES (STAINLESS)
- A11. CV FLOW CONTROL (OPENING)

COATING NOTES:

- B1. THE P.R.V. VALVE SHALL INCLUDE FACTORY INSTALLED INTERIOR EPOXY COATING.
- B2. ALL NEW AND EXISTING PIPING, VALVES, FITTINGS, METERS, ETC., INSIDE THE VAULT SHALL BE EPOXY PAINTED.
- B3. METAL SURFACES TO BE PAINTED SHALL BE PRIMED AND THEN PAINTED W/ TWO COATS OF EPOXY PAINT.
- B4. COLORS AS DIRECTED BY THE CITY ENGINEER OR CITY WATER SYSTEM SUPERINTENDENT.

VAULT NOTES:

- C1. PRE-PLUMBED PRV VAULTS ARE THE PREFERRED OPTION FOR INSTALLATION. THE USE AND LOCATION OF A PRE-PLUMBED PRV VAULT SHALL BE AS DIRECTED BY THE CITY ENGINEER FOLLOWING REVIEW OF CURRENT SITE CONDITIONS.
- C2. WHERE APPLICABLE, PRESSURE RELIEF VALVE ASSEMBLY MAY BE REQUIRED. THIS IS A CASE BY CASE ITEM DETERMINED BY THE CITY WATER DEPARTMENT (PRV VAULT WILL NEED TO BE LENGTHENED TO ACCOMMODATE SUCH VALVE)
- C3. PRECAST CONCRETE STRUCTURE CAN BE REPLACED WITH CAST-IN-PLACE CONCRETE VAULT. SUBMIT ENGINEERED CONSTRUCTION PLANS WITH REBAR DETAILS TO CITY ENGINEER FOR REVIEW AND ACCEPTANCE PRIOR TO CONSTRUCTION.
- C4. PENETRATION WALLS NEED TO BE ADEQUATELY DESIGNED STRUCTURALLY FOR ANTICIPATED THRUST.
- C5. THE PRECAST VAULT MANUFACTURER IS RESPONSIBLE FOR DESIGN RELATED TO HL-93 TRAFFIC LOADING AND THRUST. VERIFICATION OF PROPER DESIGN MUST BE PROVIDED TO THE CITY BY THE DEVELOPER, CONTRACTOR, OR PROPERTY OWNER AS THE CASE MAY BE.

GENERAL NOTES:

- A. "BLUE" BOLTS AND NUTS ARE REQUIRED BY THE CITY.
- B. ALL FITTINGS OUTSIDE OF THE VAULT ARE TO BE DUCTILE IRON MJ WITH THRUST RESTRAINT RETAINER GLANDS ("ROMAC", MARG, OR APPROVED EQUAL)
- C. STRUCTURE, PIPING & VALVE SIZES FOR P.R.V. STATIONS ON LINE SIZES GREATER THAN 12" SHALL BE SPECIFIED BY THE CITY ENGINEER.
- D. ALL SPECIFIED BRANDS OF MATERIALS SHOWN ON THESE DRAWINGS ARE "CITY STANDARDS." OTHER EQUIVALENT BRANDS MAY BE USED WITH THE PRIOR APPROVAL OF THE CITY ENGINEER AND THE CITY WATER SYSTEM SUPERINTENDENT.
- E. FIBER MESH SHALL BE ADDED TO ALL CONCRETE COLLARS ON VALVES AND MANHOLES.

PRESSURE REDUCTION STATION

PROJECT ENGINEER DATE	REV. DATE APPR.	SCALE: N. T.S.	DESIGNED <u>BKJ</u> DRAWN <u>BEB</u> CHECKED <u>BKJ</u>	 JONES & ASSOCIATES CONSULTING ENGINEERS 6080 Fashion Point Drive South Ogden, Utah 84403 (801) 476-9767 www.jonescivil.com	SOUTH WEBER CITY CORPORATION PUBLIC WORKS STANDARDS CULINARY WATER - PRESSURE REDUCTION STATION	SHEET: CS-12 OF 23 SHEETS 0
--------------------------	-----------------------	-------------------	---	---	--	---

NOTE:
GRAVEL SURFACED AREAS, SUCH AS ROADS AND SHOULDERS, PARKING AREAS, AND UNPAVED DRIVEWAYS, SHALL BE REPAIRED WITH 8" THICK (MIN.) 1" UNTREATED BASE COURSE COMPACTED TO 95% MODIFIED PROCTOR.

HOT MIX ASPHALT (HMA) PER CITY STANDARD SPECIFICATIONS. MATCH EXISTING PAVEMENT THICKNESS OR 4" MIN., WHICHEVER IS GREATER.

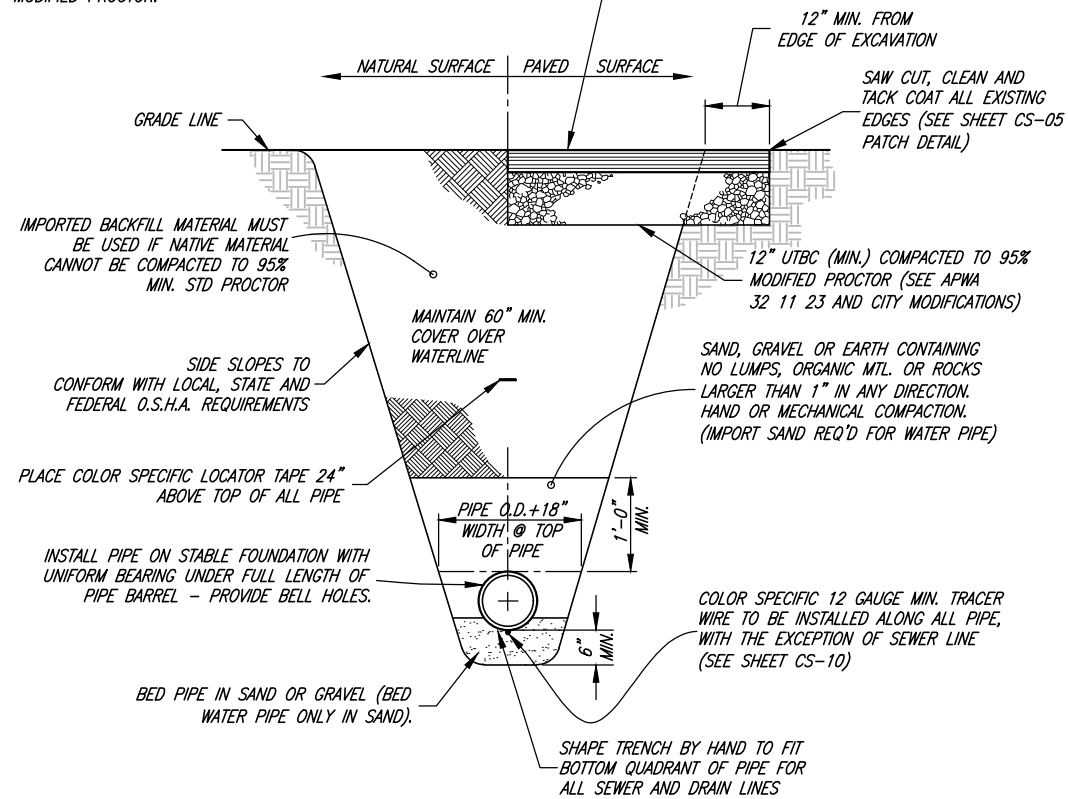

TYPICAL TRENCH SECTION
(WATER, IRRIGATION, SEWER, STORM DRAIN, AND LAND DRAIN)

TRENCH NOTES:

- A. BACKFILL PER APWA 33 05 20 AND CITY MODIFICATIONS.
- B. COMPACTION TEST REQUIRED AT SPRING-LINE FOR ALL P.V.C. OR H.D.P.E. PIPES.
- C. PAVEMENT RESTORATION PER APWA 33 05 25 AND CITY MODIFICATIONS.

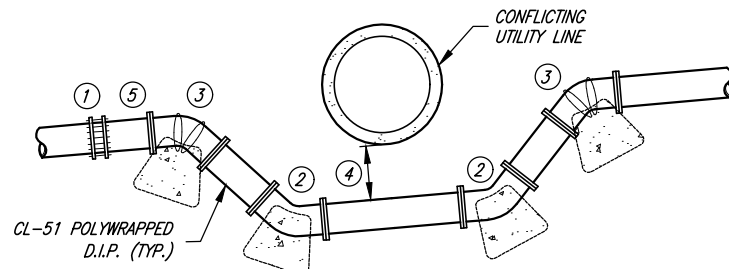

TYPICAL WATERLINE LOOP

- ① TRANSITION COUPLING; "ROMAC" MODEL 501
- ② M/J 45° BEND W/RETAINER GLANDS
- ③ CONSTRUCT THRUST BLOCKS AT EACH 45° BEND W/(3) #6 REBAR SECURING BLOCK TO FITTING (EPOXY COATING)
- ④ MINIMUM OF 12" COVER BETWEEN THE WATERLINE AND CONFLICTING UTILITY LINE TO BE CROSSED, EXCEPT LOOPS INVOLVING SEWER MAINS WHERE A MINIMUM OF 18" VERTICAL COVER ABOVE THE SEWER MAIN OR CASING THE CULINARY WATER LINE IS REQUIRED IN ACCORDANCE WITH THE STATE OF UTAH DIVISION OF DRINKING WATER RULES SECTION R309-550-7.
- ⑤ AN AIR/VACUUM RELIEF VALVE MAY BE REQUIRED ON A CASE BY CASE BASIS AS DIRECTED BY THE CITY WATER SYSTEM SUPERINTENDENT.

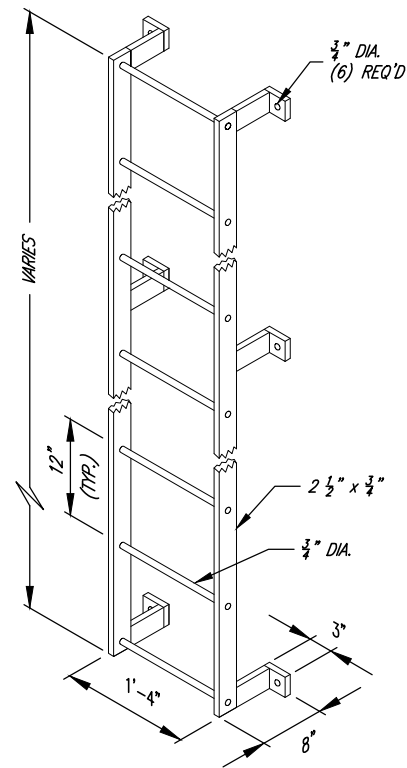

LADDER DETAIL
HOT DIP GALVANIZE AFTER FABRICATION

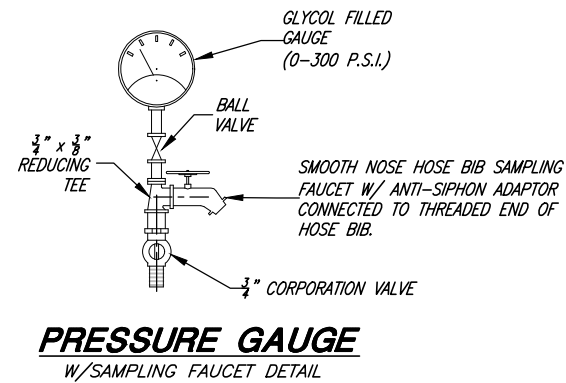

PRESSURE GAUGE
W/SAMPLING FAUCET DETAIL

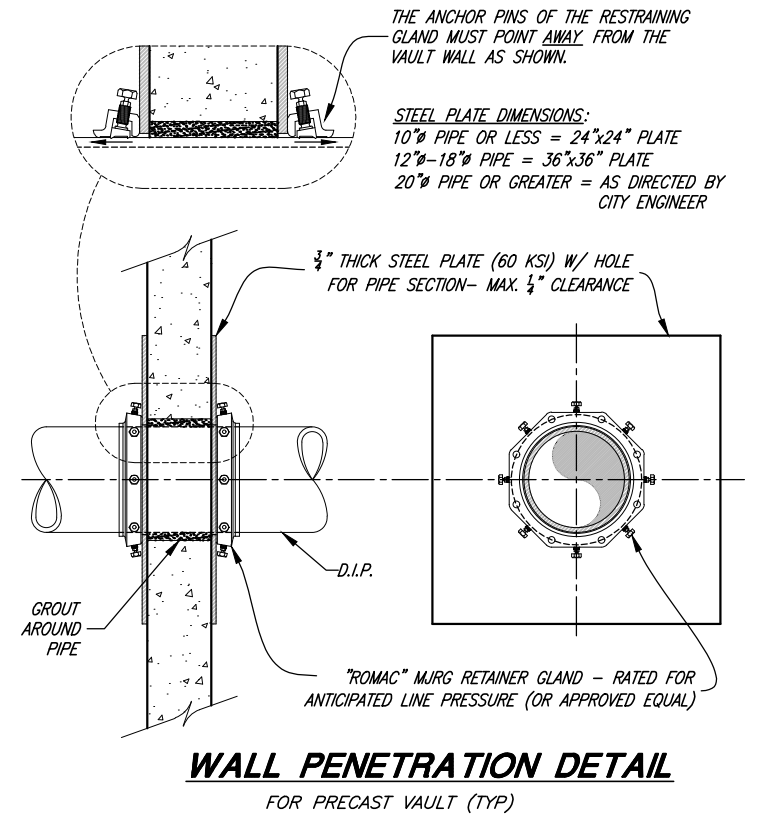

WALL PENETRATION DETAIL
FOR PRECAST VAULT (TYP)

PIPE RESTRAINT

- A1. FOR NOMINAL PIPE DIAMETERS 8" AND GREATER, ALL BENDS, CROSSES, TEES, REDUCERS, AND VALVES SHALL BE INSTALLED WITH RESTRAINING JOINTS ("MEGA-LUG" OR APPROVED EQUAL).
- A2. DESIGN SHALL ALSO BE REQUIRED TO ENSURE ADEQUATE RESTRAINT FOR PIPING JOINTS NEAR FITTINGS BASED ON PIPE DIAMETER AND PIPE PRESSURE.

THRUST BLOCKING NOTES:

- B1. CONCRETE SHALL NOT BE PLACED WITHIN 1-1/2" OF JOINTS AND BOLTS. COVER ALL METAL CONTACT AREAS WITH A POLY WRAP PRIOR TO CONCRETE PLACEMENT.
- B2. IN THE ABSENCE OF A SOILS REPORT, ALL THRUST BLOCKS SHALL BE SIZED ON THE BASIS OF A MAXIMUM LATERAL BEARING VALUE FOR 2000 P.S.F. AND A THRUST RESULTING FROM 200% OF THE WATER LINE STATIC LINE TEST.
- B3. THRUST BLOCKS ARE REQUIRED AT ALL BENDS OF 22-1/2" OR MORE. 11-1/4" BENDS SHALL HAVE RETAINER GLANDS.
- B4. CONCRETE SHALL HAVE A MINIMUM COMPRESSIVE STRENGTH OF 3000 PSI IN 28 DAYS.

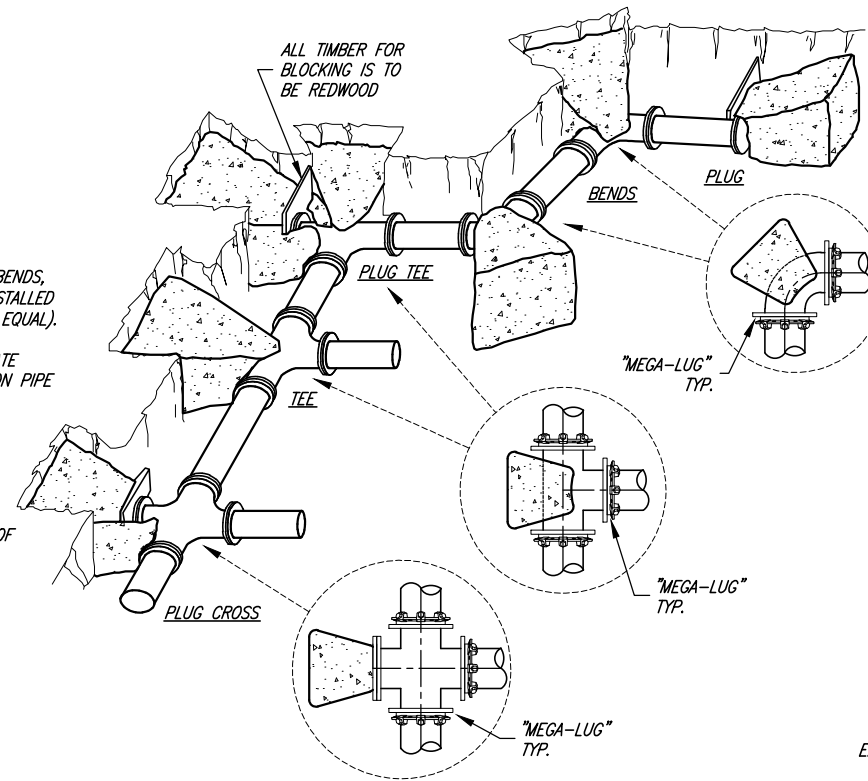

TYPICAL RETAINER GLANDS & THRUST BLOCKING

THRUST PER PSI OF WATER PRESSURE AT VARIOUS FITTINGS				
PIPE SIZE (IN.)	DEAD END OR TEE (LB.)	90° ELBOW (LB.)	45° ELBOW (LB.)	22-1/2° ELBOW (LB.)
4	19	27	15	7
6	39	55	30	15
8	67	94	51	26
10	109	154	84	43
12	155	218	119	61
14	210	296	161	82
16	272	383	209	106
18	351	494	269	137
20	434	611	333	169
24	623	878	487	244
30	947	1,332	722	377
36	1,356	1,905	1,032	542

- NOTES:**
- C1. IN USING THE ABOVE TABLE, USE THE MAXIMUM INTERNAL PRESSURE ANTICIPATED (I.E. HYDROSTATIC TEST PRESSURE, POSSIBLE SURGE PRESSURE DUE TO PUMP SHUT OFF, ETC.).
 - C2. SEE SOILS REPORT FOR BEARING STRENGTH OF SOIL. IN THE ABSENCE OF A SOILS REPORT, AN AVERAGE SOIL (SPADABLE MEDIUM CLAY) CAN BE ASSUMED TO HAVE A BEARING STRENGTH OF 2000 P.S.F.

EXAMPLE:

8-INCH 90° ELBOW, PRESSURE 200 LB./SQ. IN.
FROM TABLE: THRUST = 94 X 200 = 18,800 LB.
ASSUME BEARING STRENGTH = 2,000 LB./SQ. FT.

18,800 / 2,000 = 9.4 SQ. FT. AREA OF BEARING REQUIRED FOR THRUST BLOCK

PROJECT ENGINEER	REV.	DATE	APPR.
DATE			

SCALE:

N. T.S.

DESIGNED BKJ
DRAWN BEB
CHECKED BKJ



CONSULTING ENGINEERS
6080 Fashion Point Drive
South Ogden, Utah 84403 (801) 476-9767
www.jonescivil.com

SOUTH WEBER CITY CORPORATION
PUBLIC WORKS STANDARDS
CULINARY WATER - THRUST BLOCK, WATERLINE LOOP, PIPE TRENCH & MISC. VAULT DETAILS

SHEET:
CS-13
OF 23 SHEETS
0

GENERAL NOTES:

- ALL SANITARY SEWER LATERAL CONNECTIONS ON SEWER MAINS IN NEW SUBDIVISIONS SHALL BE MADE WITH IN LINE PRE-FORMED WYES OR TEES UNLESS OTHERWISE APPROVED BY THE CITY ENGINEER.
- FLOWLINE ELEVATION OF LATERALS SHALL EQUAL THE INSIDE TOP OF PIPE ON MAINLINE AT THE CONNECTING POINT (THE LATERAL TAP SHALL BE IN THE TOP QUARTER OF THE SEWER MAIN LINE PREFERABLY IN THE 10:00 OR 2:00 POSITION).
- SANITARY SEWER SERVICE LATERAL CONNECTIONS SHALL NOT BE ALLOWED IN SEWER MANHOLES.
- SANITARY SEWER PIPES SHALL BE "GREEN" IN COLOR. LAND DRAIN MAIN LINES SHALL BE "GREEN" IN COLOR AND LAND DRAIN LATERAL LINES SHALL BE "WHITE" IN COLOR. IRRIGATION PIPES SHALL BE "PURPLE" IN COLOR. PREVIOUS YEARS PIPE COLORS VARY THROUGHOUT THE CITY. CONTRACTOR TO VERIFY EXISTING PIPE PRIOR TO MAKING ANY CONNECTION.
- INSERTA TEE PRODUCT IS NOT APPROVED BY THE CITY
- ALL CLEANOUTS SHALL BE MARKED AND FITTED WITH A METAL LID FOR LOCATION PURPOSES
- ALL CULINARY WATER MAINS AND SERVICES MUST MAINTAIN A MINIMUM SEPARATION FROM ALL SEWER MAINS AND LATERALS OF 10'-0" HORIZONTAL AND 18" VERTICAL IN ACCORDANCE WITH THE STATE OF UTAH DIVISION OF DRINKING WATER RULES SECTION R309-550-7
- ALL SANITARY SEWER LINES SHALL BE INSPECTED BY MEANS OF VIDEO CAMERA WHEN CONSTRUCTED.
- STAMPED STAINLESS STEEL PINS USED FOR LATERAL LOCATING ARE REQUIRED BY THE CITY. BLANK S.S. PINS SHALL BE PROVIDED BY THE CITY AND INSTALLED AND STAMPED BY THE CONTRACTOR DURING ALL NEW CONSTRUCTION OR RESTORED WHEN REPLACING DAMAGED CURB & GUTTER DUE TO ANY CONSTRUCTION RELATED ACTIVITY. S.S. PINS SHALL BE STAMPED "S" FOR SANITARY SEWER, "W" FOR CULINARY WATER, AND "L" FOR LAND DRAIN.
- DOWNSTREAM LAND DRAIN CONNECTION TO AN EXISTING STORM DRAIN SYSTEM IS REQUIRED.

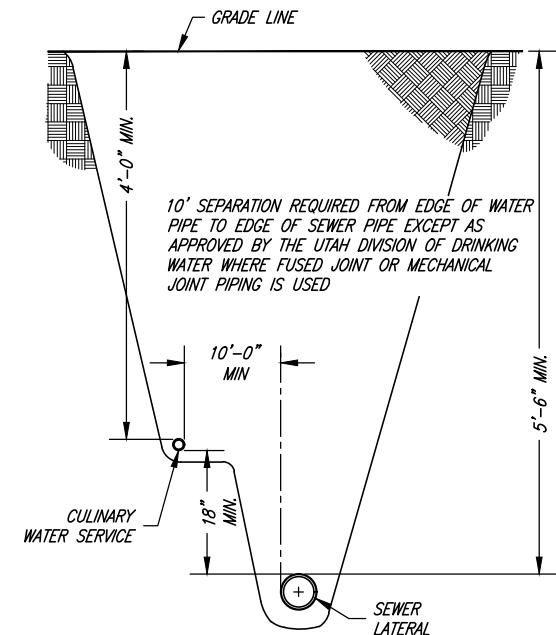

COMBINED WATER SERVICE & SEWER LATERAL TRENCH SECTION

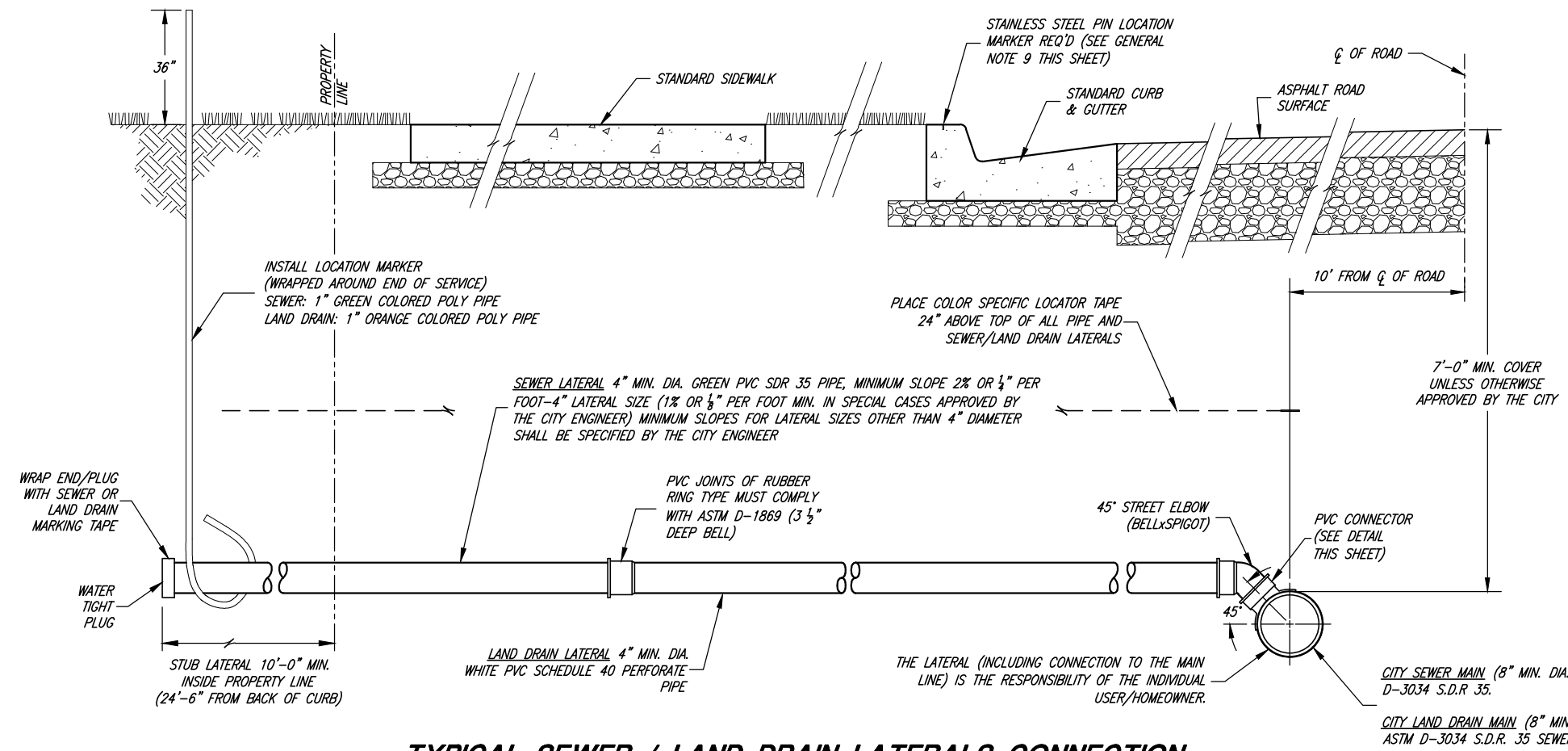
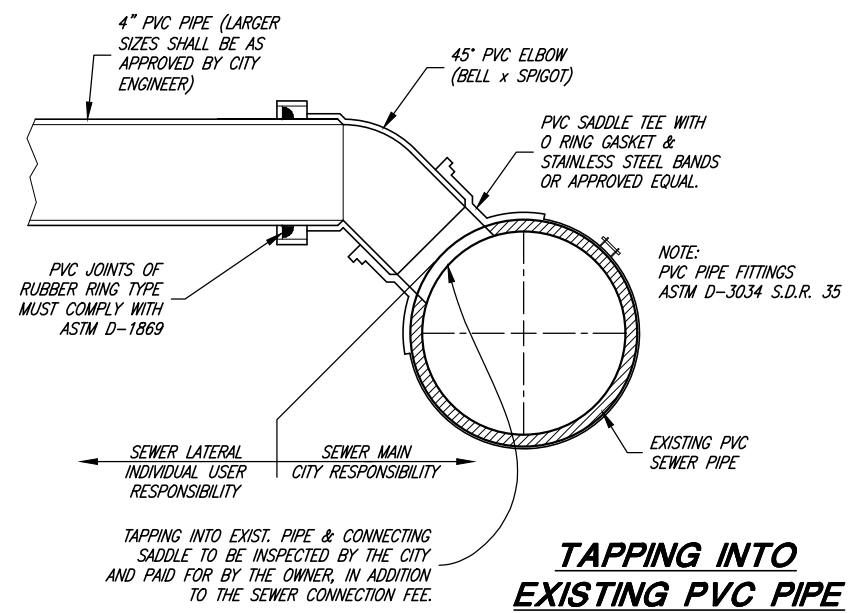
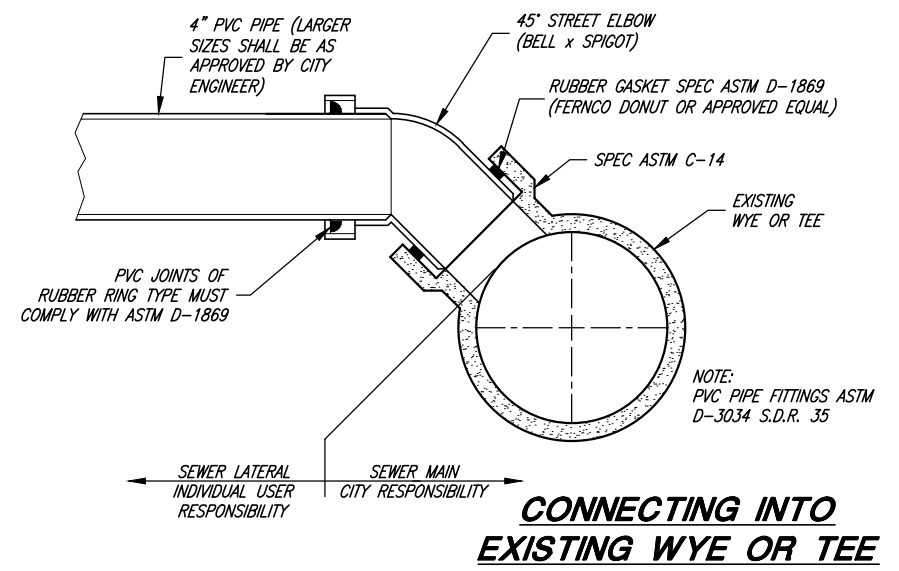

TYPICAL SEWER / LAND DRAIN LATERALS CONNECTION

PROJECT ENGINEER	
DATE	

REV.	DATE	APPR.

SCALE:	N. T.S.
DESIGNED	BKJ
DRAWN	BEB
CHECKED	BKJ

JONES & ASSOCIATES
CONSULTING ENGINEERS
 6080 Fashion Point Drive
 South Ogden, Utah 84403 (801) 476-9767
 www.jonescivil.com

SOUTH WEBER CITY CORPORATION
PUBLIC WORKS STANDARDS
SANITARY SEWER - LATERAL & CONNECTION DETAILS

DROP MANHOLE NOTES:

- A. USE DROP MANHOLE ONLY WHEN DROP EXCEEDS 2'-0" (UAC R317-3)
- B. DROP MANHOLE SHALL CONSIST OF ASTM D3034 SDR 35 PVC PIPE WITH SDR 35 PVC GASKETED FITTINGS.
- C. DUE TO THE UNEQUAL EARTH PRESSURES THAT WOULD RESULT FROM THE BACKFILLING OPERATION IN THE VICINITY OF THE MANHOLE, THE ENTIRE OUTSIDE DROP CONNECTIONS SHALL BE ENCASED IN CONCRETE. (UAC R317-3)
- D. DROP MANHOLES SHOULD BE USED ON STREETS WITH GRADES 8% OR GREATER OR AS OTHERWISE DIRECTED BY THE CITY ENGINEER.

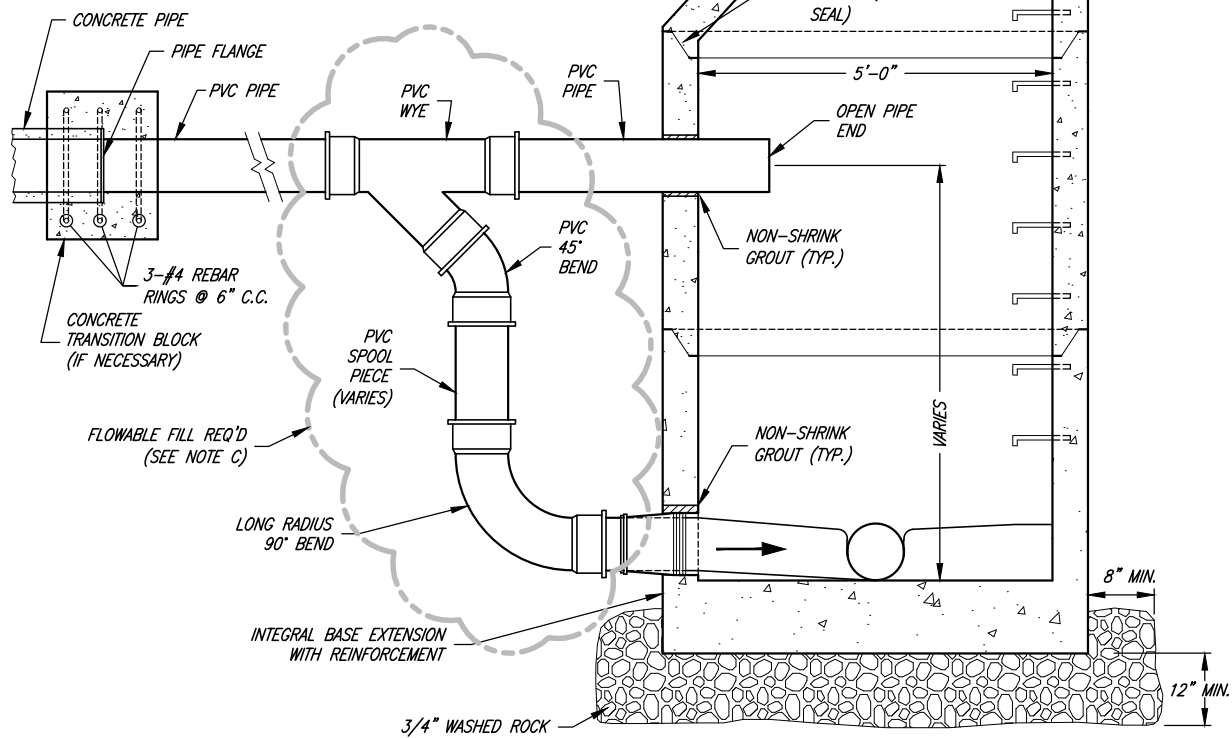

TYPICAL DROP MANHOLE SECTION

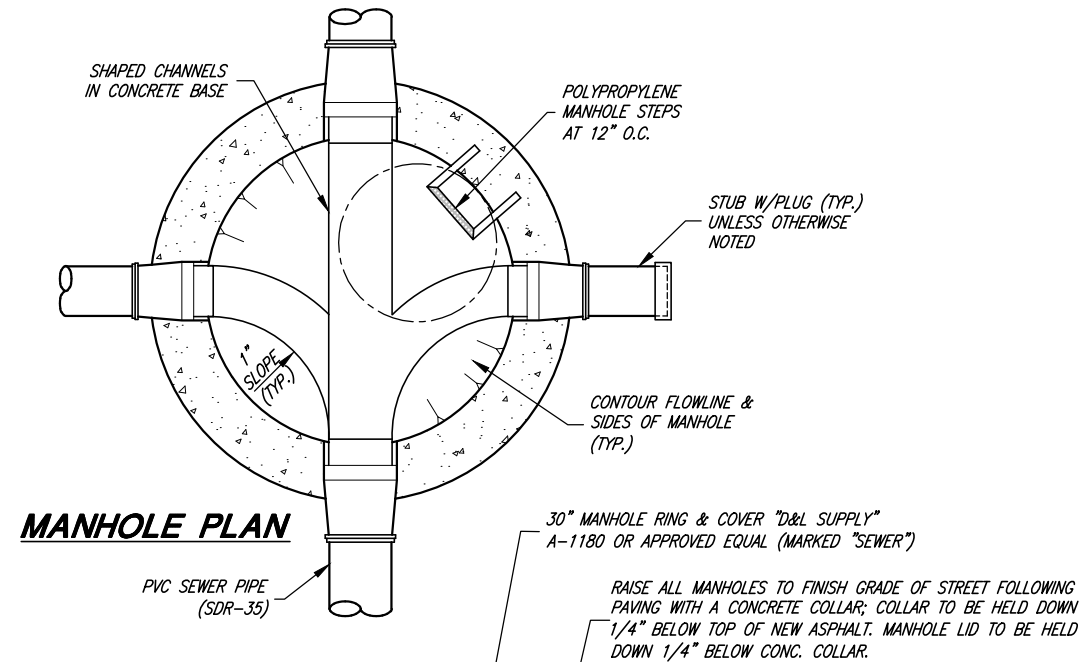

MANHOLE PLAN

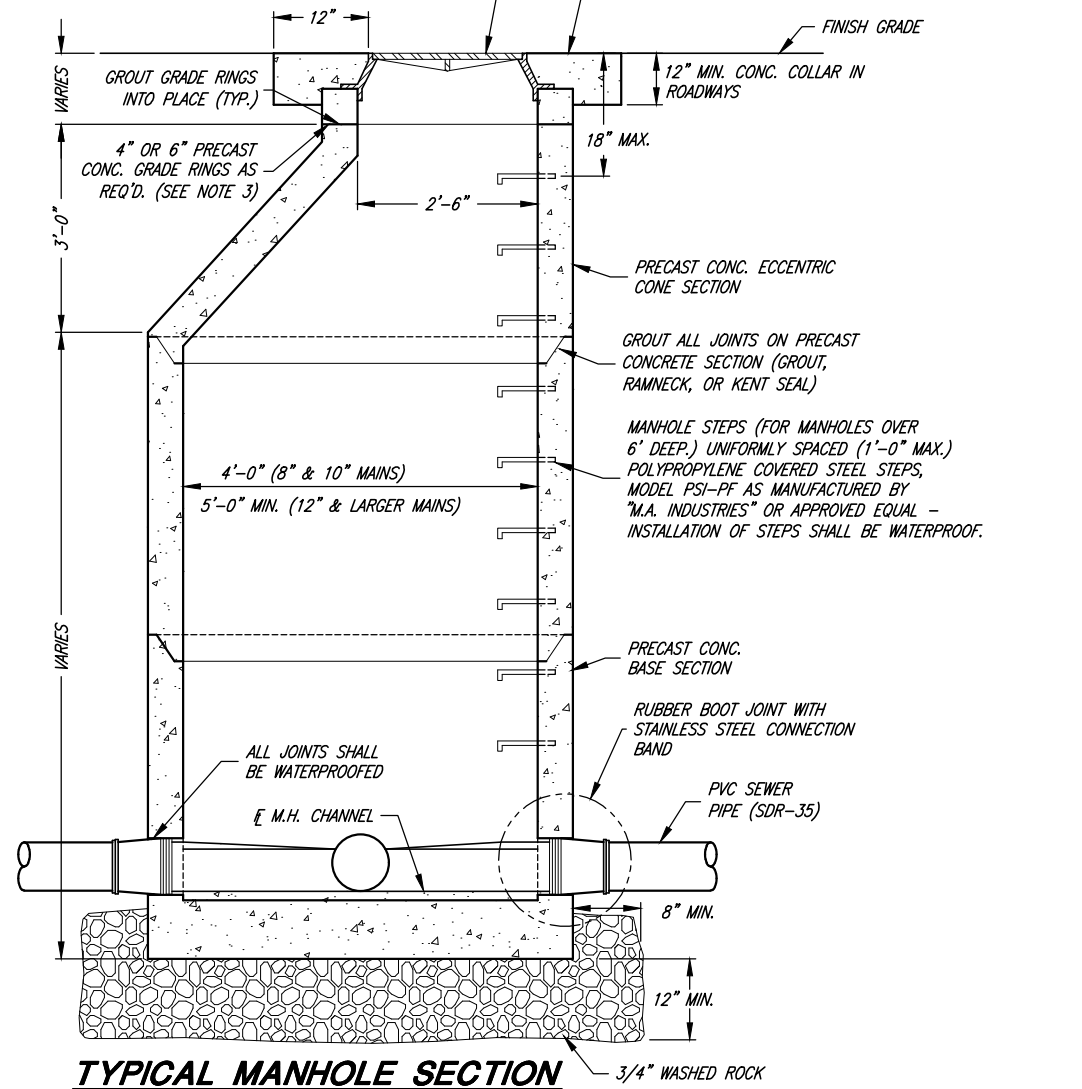

TYPICAL MANHOLE SECTION

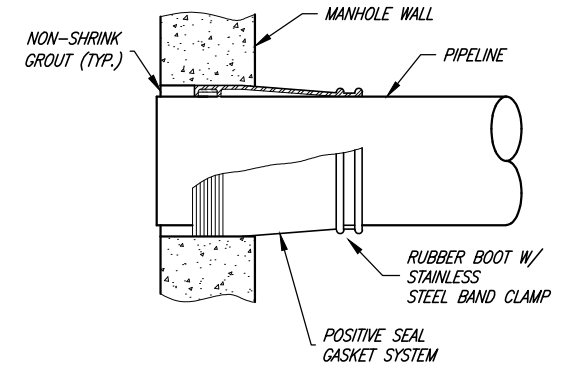

RUBBER BOOT DETAIL

GENERAL NOTES:

1. SECURE INVERTS IN ALL MANHOLES DURING CONSTRUCTION SO AS TO PREVENT GRAVEL AND OTHER DEBRIS FROM COLLECTING INSIDE.
2. A LARGER DIAMETER MANHOLE MAY BE REQUIRED BY THE DESIGN ENGINEER AFTER EVALUATION OF THE NUMBER, SIZE, AND ANGLE OF THE PIPES THAT CONNECT TO THE MANHOLE.
3. NO MORE THAN 12" OF GRADE RINGS TO BE ALLOWED ON ANY MANHOLE.
4. ALL TERMINATING SEWER MAINS SHALL END WITH A CITY STANDARD MANHOLE.
5. SERVICE LATERAL CONNECTIONS SHALL NOT BE ALLOWED IN SEWER MANHOLES.
6. ALL SANITARY SEWER LINES SHALL BE INSPECTED BY MEANS OF VIDEO CAMERA AND AIR TESTED WHEN CONSTRUCTED. SEE APWA 33 08 00 AND CITY MODIFICATIONS FOR MORE INFORMATION.
7. FIBER MESH SHALL BE ADDED TO ALL CONCRETE COLLARS ON VALVES AND MANHOLES.
8. WHERE THE DIFFERENCE IN ELEVATION BETWEEN THE INCOMING SEWER AND MANHOLE INVERT IS LESS THAN 24 INCHES, THE INVERT SHOULD BE FILLETED.

PROJECT ENGINEER	REV.	DATE	APPR.
DATE			

SCALE:

N. T.S.

DESIGNED BKJ
 DRAWN BEB
 CHECKED BKJ



CONSULTING ENGINEERS
 6080 Fashion Point Drive
 South Ogden, Utah 84403 (801) 476-9767
 www.jonescivil.com

SOUTH WEBER CITY CORPORATION
PUBLIC WORKS STANDARDS

SANITARY SEWER - TYPICAL MANHOLES & DETAILS

SHEET:

CS-15

OF 23 SHEETS

0

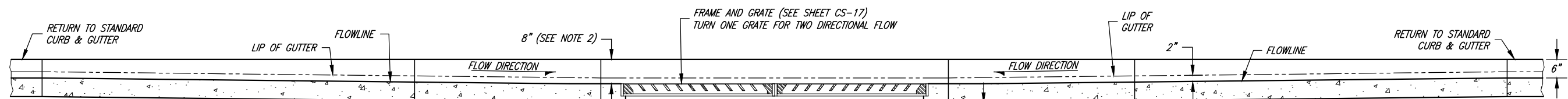
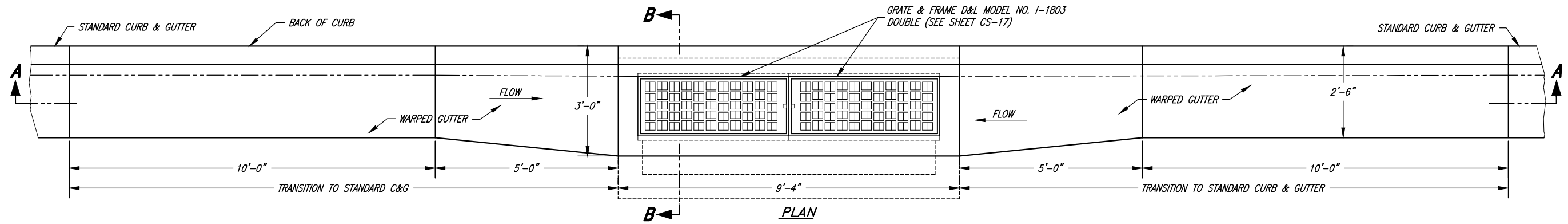

STANDARD CATCH BASIN DIMENSION TABLE

PIPE SIZE (IN.)	"X"	SINGLE CATCH BASIN		"Z" MIN.
		"Y" (ANGLE A)	"Y" (ANGLE B)	
15	2'-6"	4'-0"	4'-0"	2'-0"
18	2'-6"	4'-0"	4'-0"	2'-6"
21	4'-0"	4'-0"	4'-0"	3'-0"
24	4'-0"	4'-0"	5'-0"	3'-0"
30	4'-0"	4'-0"	6'-0"	3'-6"
36	4'-0"	5'-0"	6'-0"	4'-0"
42	6'-0"	6'-0"	7'-0"	5'-0"
48	6'-0"	6'-0"	8'-0"	5'-6"

- GENERAL NOTES:**
- ALL CATCH BASIN BOX SIZES REFLECT DIMENSIONS FOR THE MINIMUM 15" PIPE SIZE. BOX DIMENSIONS MUST INCREASE PROPORTIONALLY TO ACCOMMODATE LARGER PIPE SIZES.
 - DEPTH MAY VARY FROM 6" TO 10" AS DIRECTED BY THE CITY ENGINEER
 - CAST-IN-PLACE CONCRETE CATCH BASINS CAN BE REPLACED WITH PRECAST CONCRETE CATCH BASINS WITH HL-93 DECK LOADING AND COMPARABLE SIZE.
 - ALL BOXES SHALL BE FORMED ON THE INSIDE AND OUTSIDE OF THE BOX AND INSPECTED BY THE CITY PRIOR TO THE PLACING OF CONCRETE.
 - DOUBLE CATCH BASINS WILL BE REQUIRED IN LOCATIONS SPECIFIED BY THE CITY ENGINEER (TYPICALLY IN LOW SPOTS OR WHERE ADDITIONAL INLET CAPACITY IS NEEDED).
 - STORM DRAIN LINES SHALL BE 15 INCH MINIMUM DIAMETER REINFORCED CONCRETE PIPE (RCP), OF APPROPRIATE CLASS.

DOUBLE CATCH BASIN

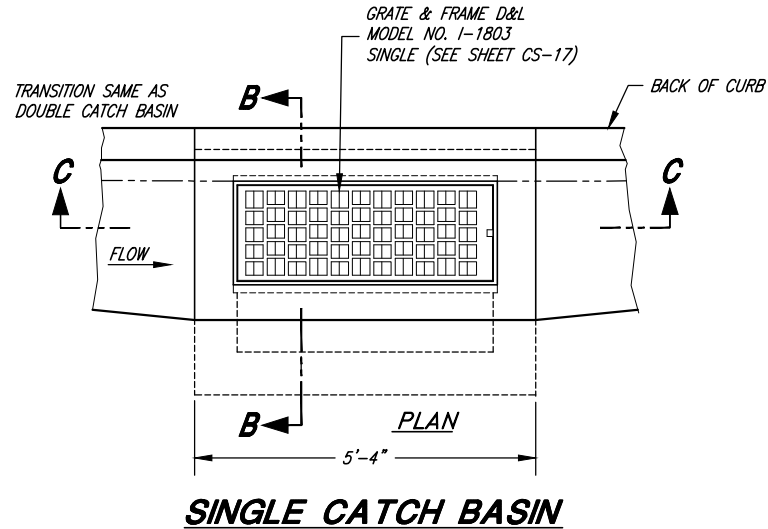
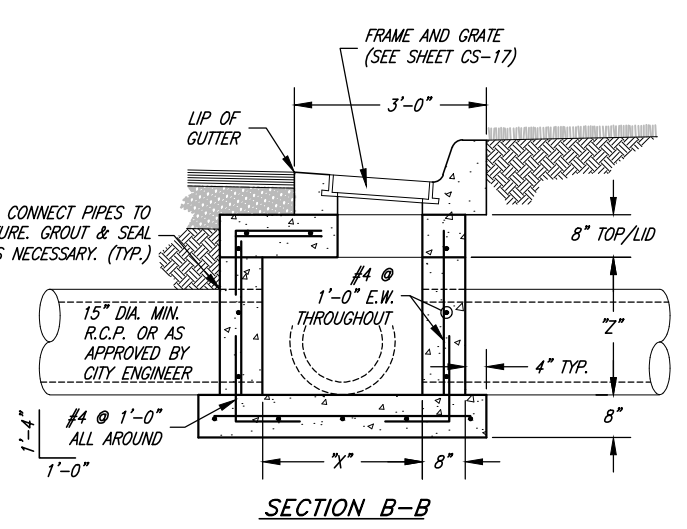
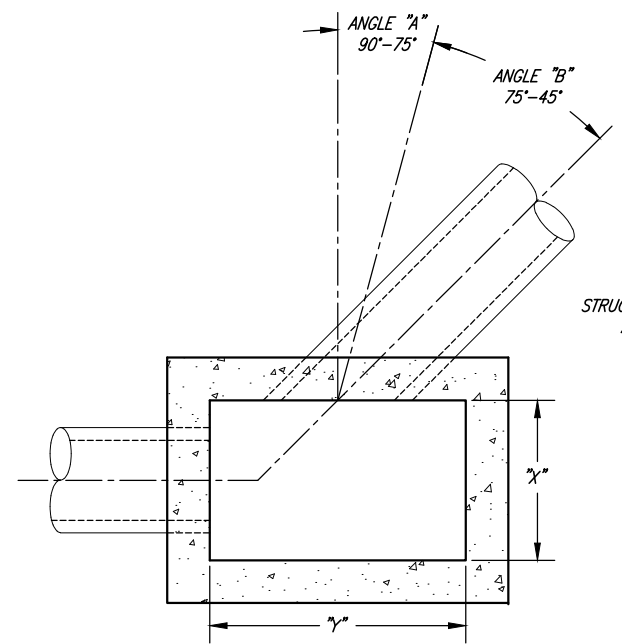

SINGLE CATCH BASIN

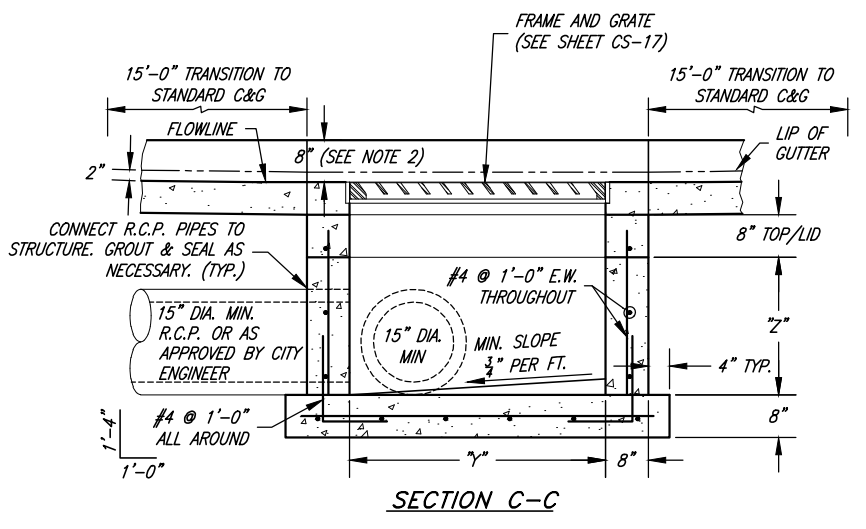

PROJECT ENGINEER	REV.	DATE	APPR.
DATE			

SCALE: N.T.S.
 DESIGNED: BKJ
 DRAWN: BEB
 CHECKED: BKJ

JONES & ASSOCIATES
 CONSULTING ENGINEERS
 6080 Fashion Point Drive
 South Ogden, Utah 84403 (801) 476-9767
 www.jonescivil.com

SOUTH WEBER CITY CORPORATION
 PUBLIC WORKS STANDARDS
STORM DRAIN - SINGLE AND DOUBLE CATCH BASIN DETAILS

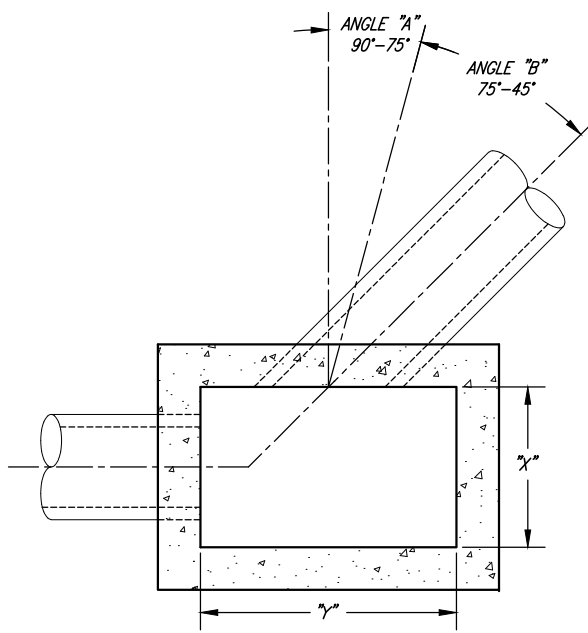

PIPE SIZE (IN.)	"X"	INLET BOX		"Z" MIN.
		"Y" (ANGLE A)	"Y" (ANGLE B)	
15	2'-6"	4'-0"	4'-0"	2'-0"
18	2'-6"	4'-0"	4'-0"	2'-6"
21	4'-0"	4'-0"	4'-0"	3'-0"
24	4'-0"	4'-0"	5'-0"	3'-0"
30	4'-0"	4'-0"	6'-0"	3'-6"
36	4'-0"	4'-0"	6'-0"	4'-0"
42	6'-0"	6'-0"	7'-0"	5'-0"
48	6'-0"	6'-0"	8'-0"	5'-6"

GENERAL NOTE:
 STORM DRAIN LINES SHALL BE 15 INCH MINIMUM DIAMETER REINFORCED CONCRETE PIPE (RCP), OF APPROPRIATE CLASS.

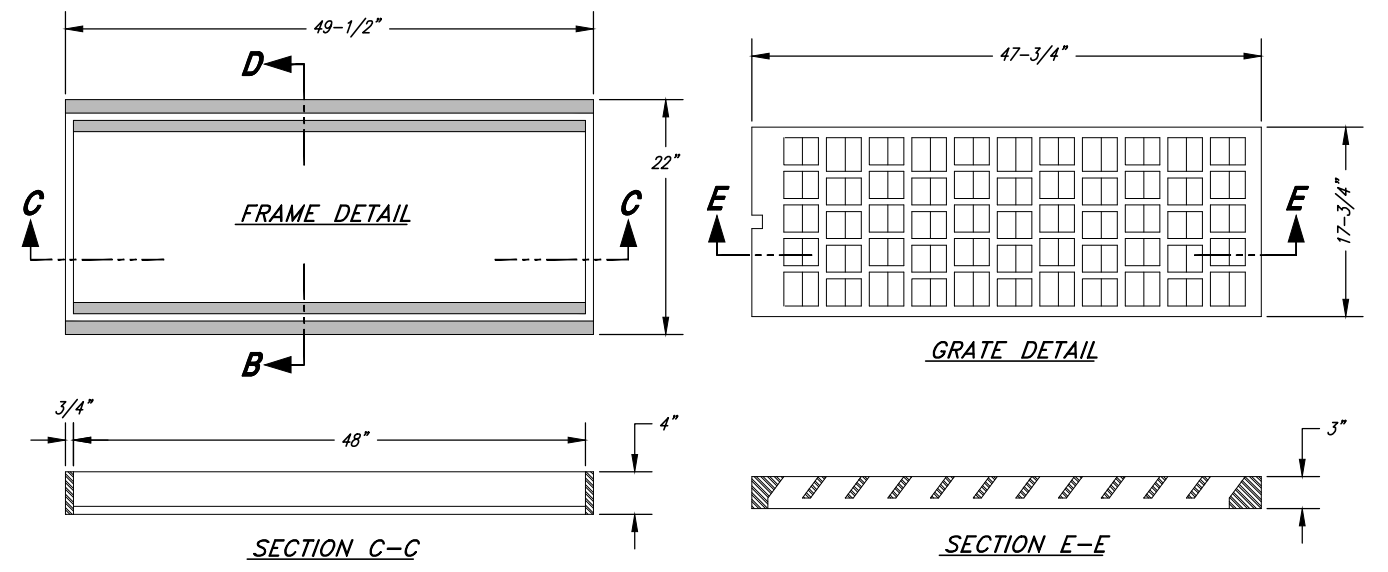

FRAME & GRATE DETAILS

- FRAME AND GRATE NOTES:**
- A1. GRATE AND FRAME SHALL BE AS MANUFACTURED BY "D&L SUPPLY" I-1803
 - B1. BICYCLE SAFE GRATE REQUIRED.
 - C1. "OR EQUAL" GRATES AND FRAMES WILL BE CONSIDERED AS APPROVED BY THE CITY ENGINEER.

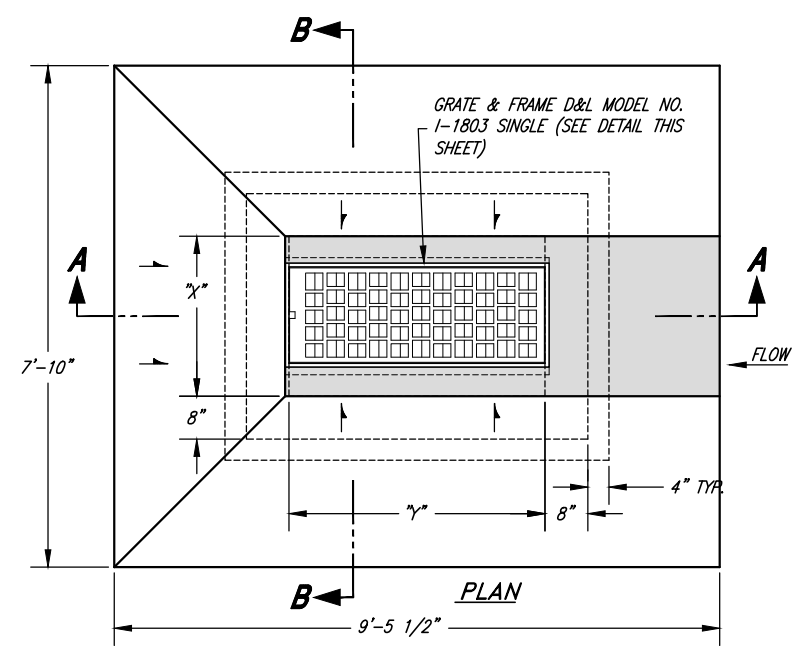
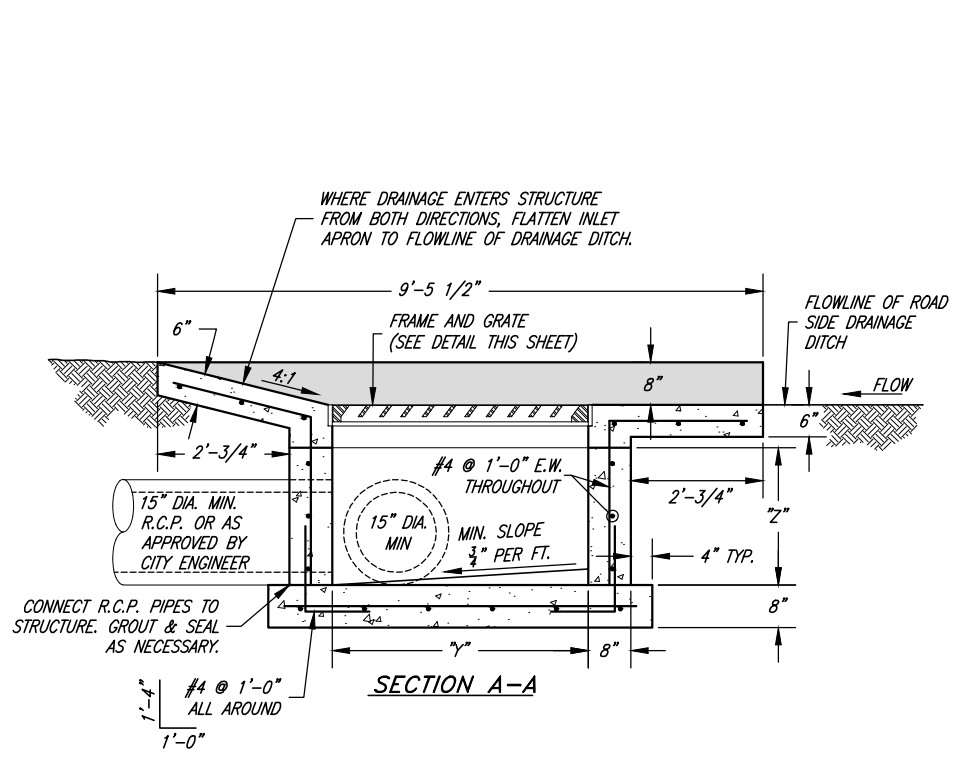
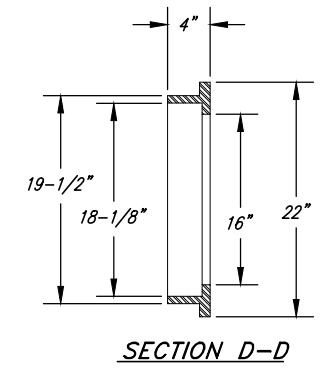

DRAINAGE DITCH / PARKING LOT INLET BOX

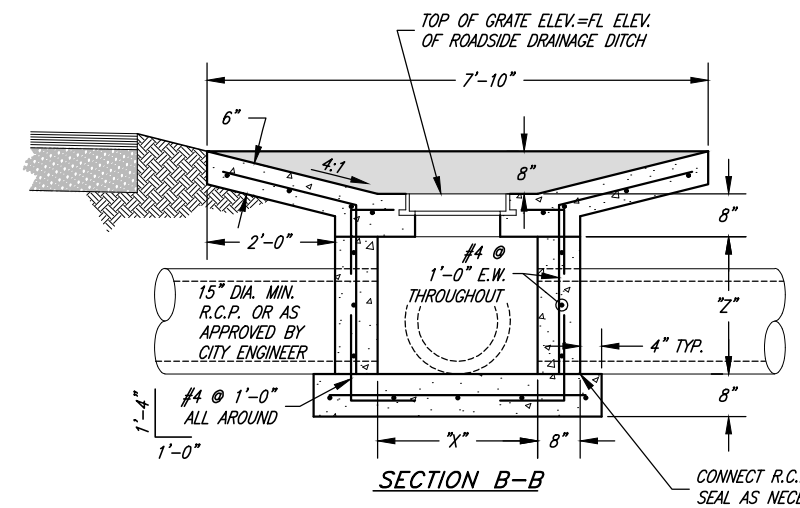

- DRAINAGE BOX NOTES:**
1. ALL BOX SIZES REFLECT DIMENSIONS FOR THE MINIMUM 15" PIPE SIZE. BOX DIMENSIONS MUST INCREASE PROPORTIONALLY TO ACCOMMODATE LARGER PIPE SIZES. (SEE TABLE THIS SHEET)
 2. CAST-IN-PLACE CONCRETE STRUCTURES CAN BE REPLACED WITH PRECAST CONCRETE STRUCTURES WITH HL-93 DECK LOADING AND COMPARABLE SIZE.
 3. ALL BOXES SHALL BE FORMED ON THE INSIDE AND OUTSIDE OF THE BOX AND INSPECTED BY THE CITY PRIOR TO THE PLACING OF CONCRETE.

PROJECT ENGINEER	REV.	DATE	APPR.
DATE			

SCALE: N.T.S.
 DESIGNED: BKJ
 DRAWN: BEB
 CHECKED: BKJ

J&A CONSULTING ENGINEERS
 6080 Fashion Point Drive
 South Ogden, Utah 84403 (801) 476-9767
 www.jonescivil.com

SOUTH WEBER CITY CORPORATION
PUBLIC WORKS STANDARDS
STORM DRAIN - DRAINAGE INLET BOX & GENERAL GRATE AND FRAME DETAILS

PIPE SIZES		JUNCTION MANHOLE (ANGLE / ARC DISTANCE)										
M.H. SIZE	IN-LINE M.H.	180°	90°	85°	80°	75°	70°	65°	60°	55°	50°	45°
4" M.H.	15"-24"	15"-18"	15"-18"	15"	15"	---	---	---	---	---	---	---
5" M.H.	27"-30"	21"-24"	21"-24"	18"-21"	18"-21"	15"-18"	15"-18"	15"	---	---	---	---
6" M.H.	36"-48"	27"-30"	27"-30"	24"-27"	24"	21"-24"	21"	18"	15"-18"	15"	---	---
7" M.H.	54"	36"	36"	30"	27"-30"	27"	24"	21"-24"	21"	18"	15"	---
8" M.H.	60"	42"	42"	36"	36"	30"	27"-30"	27"	24"	21"	18"	---

- SIZING NOTES:**
- SUGGESTED "A" DISTANCE IS 6" OR GREATER FOR 48", 60" AND 72" DIAMETER MANHOLES
 - SUGGESTED "A" DISTANCE IS 8" OR GREATER FOR 84" AND 96" DIAMETER MANHOLES

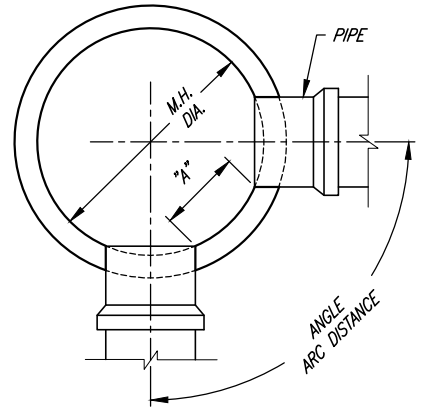

OPENING IN PIPE SCORED BY MFG. BREAKOUT OR SAW CUT IN FIELD AT LOCATIONS. CUT BACK REINF. MESH AND GROUT OVER BREAK OUT SURFACES

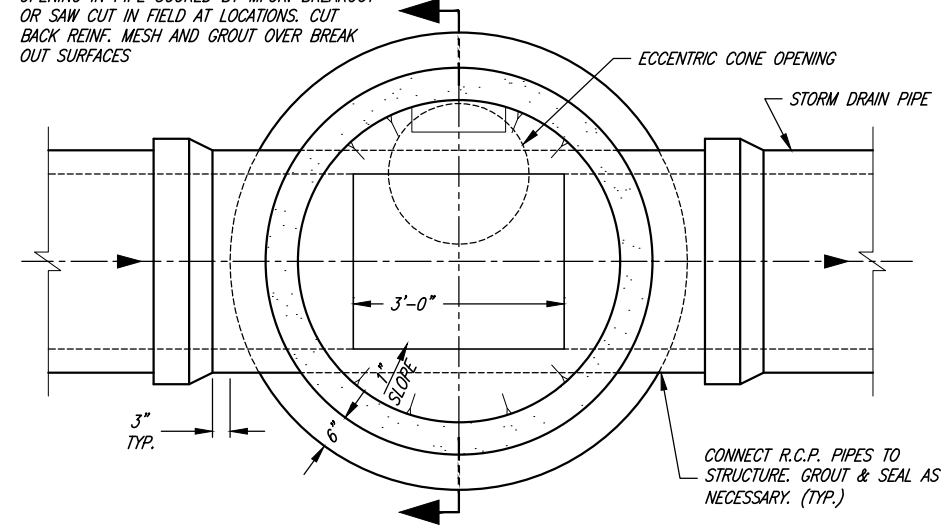

TYPICAL LINE MANHOLE

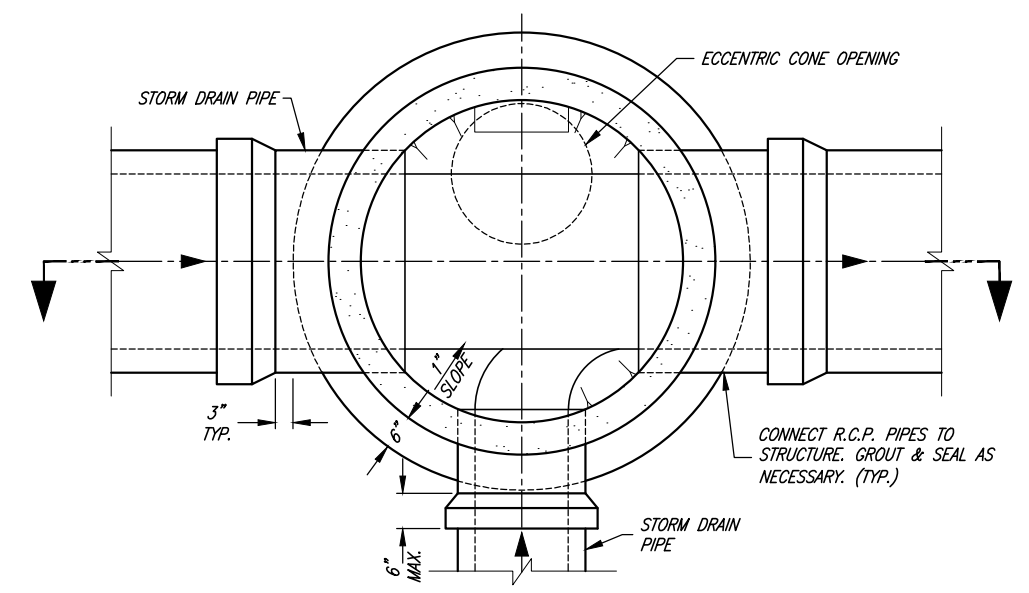

TYPICAL JUNCTION MANHOLE

- GENERAL NOTES:**
- STORM DRAIN MANHOLE DIAMETER TO BE DETERMINED BY THE DESIGN ENGINEER AFTER EVALUATION OF THE NUMBER, SIZE, AND PIPE ENTRY ANGLE OF THE PIPES THAT CONNECT TO THE MANHOLE.
 - NO MORE THAN 12" OF GRADE RINGS TO BE ALLOWED ON ANY MANHOLE
 - PLYWOOD COVERS SHALL BE USED AT MANHOLE FLOOR TO COVER FLOWLINE DURING CONSTRUCTION AND MAINTENANCE ACTIVITIES.
 - ALL INTERIOR JOINTS SHALL BE SMOOTH AND EVENLY GROUTED WITH NON-SHRINK GROUT MIX.
 - MANHOLE STEPS UNIFORMLY SPACED (1'-0" MAX.) POLYPROPYLENE COVERED STEEL STEPS, MODEL PSI-PF AS MANUFACTURED BY "M.A. INDUSTRIES" OR APPROVED EQUAL-INSTALLATION OF STEPS SHALL BE WATERPROOF.
 - FIBER MESH SHALL BE ADDED TO ALL CONCRETE COLLARS ON VALVES AND MANHOLES.
 - STORM DRAIN LINES SHALL BE 15 INCH MINIMUM DIAMETER REINFORCED CONCRETE PIPE (RCP), OF APPROPRIATE CLASS.

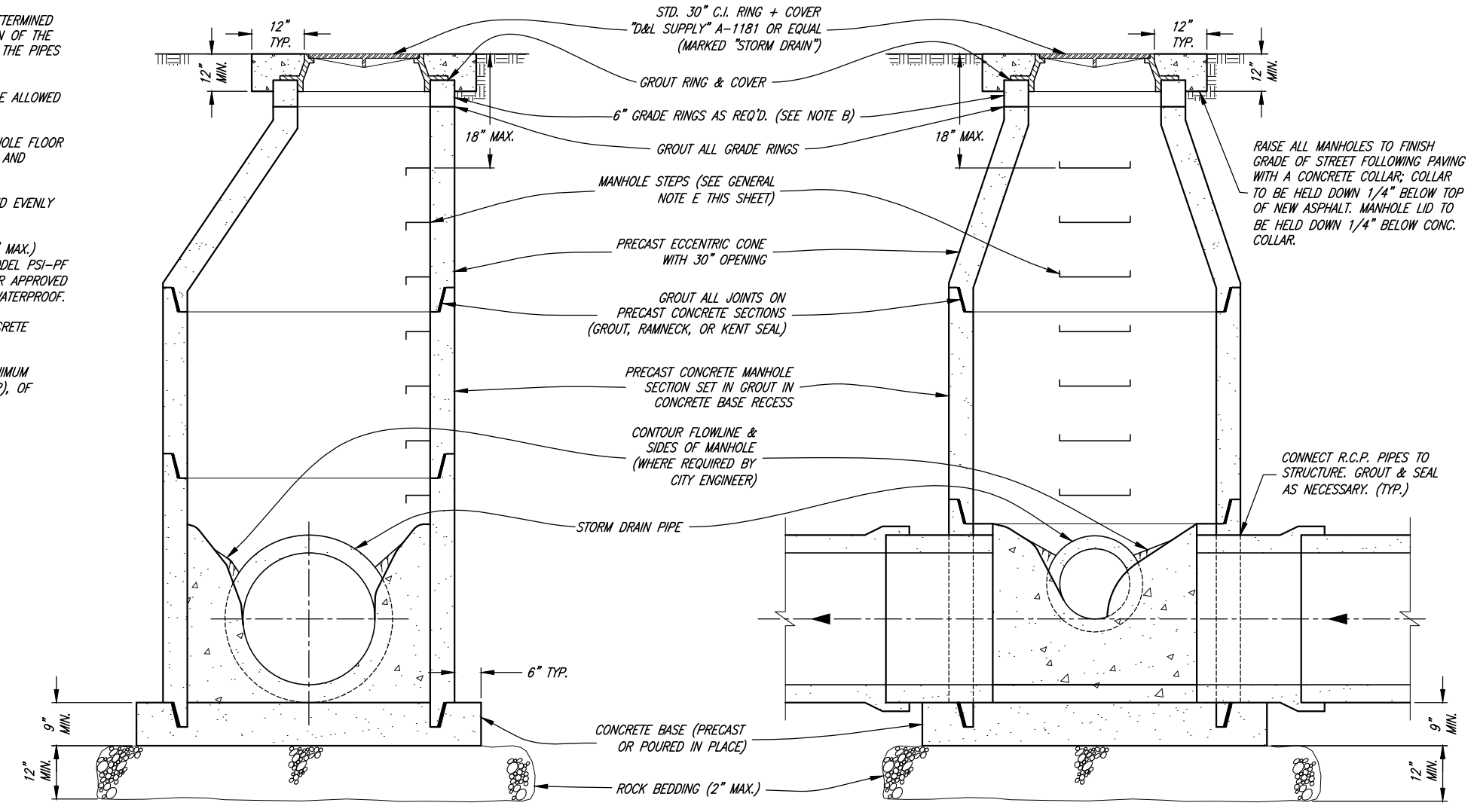

PROJECT ENGINEER	REV.	DATE	APPR.
DATE			

SCALE: N.T.S.
 DESIGNED: BKJ
 DRAWN: BEB
 CHECKED: BKJ

JONES & ASSOCIATES
 CONSULTING ENGINEERS
 6080 Fashion Point Drive
 South Ogden, Utah 84403 (801) 476-9767
 www.jonescivil.com

SOUTH WEBER CITY CORPORATION
 PUBLIC WORKS STANDARDS
STORM DRAIN - MANHOLE DETAILS

SHEET: **CS-18**
 OF 23 SHEETS
 0

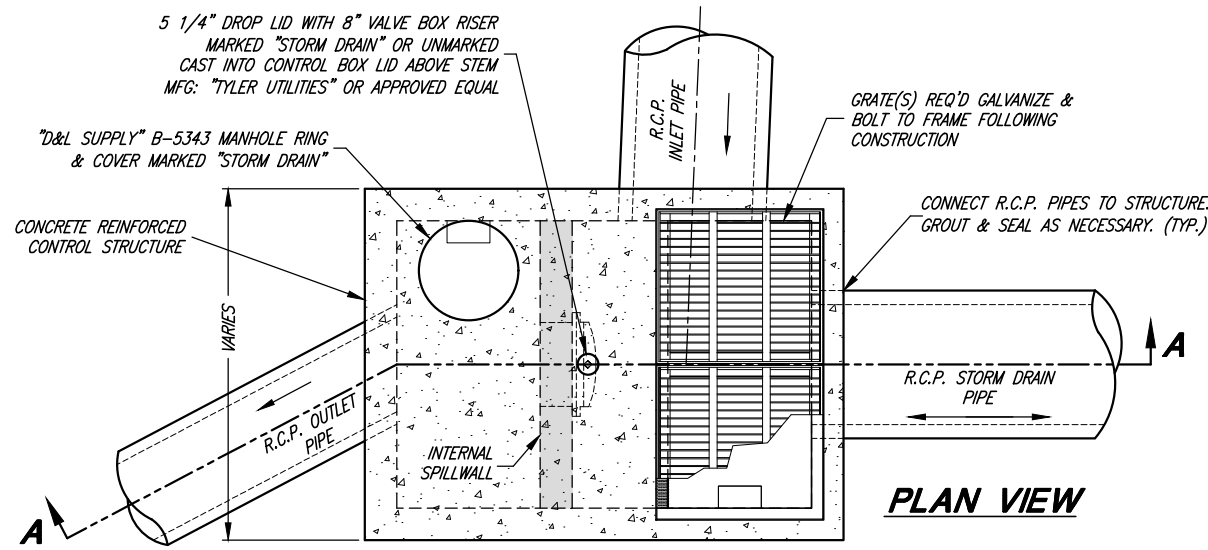

DETENTION INLET/OUTLET CONTROL STRUCTURE
(PRECAST OR CAST-IN-PLACE)

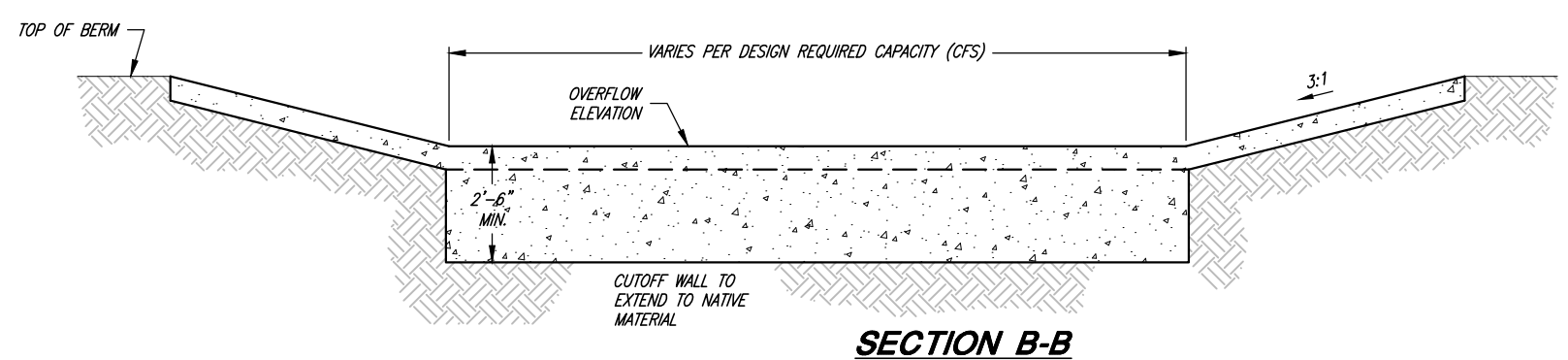

SECTION B-B

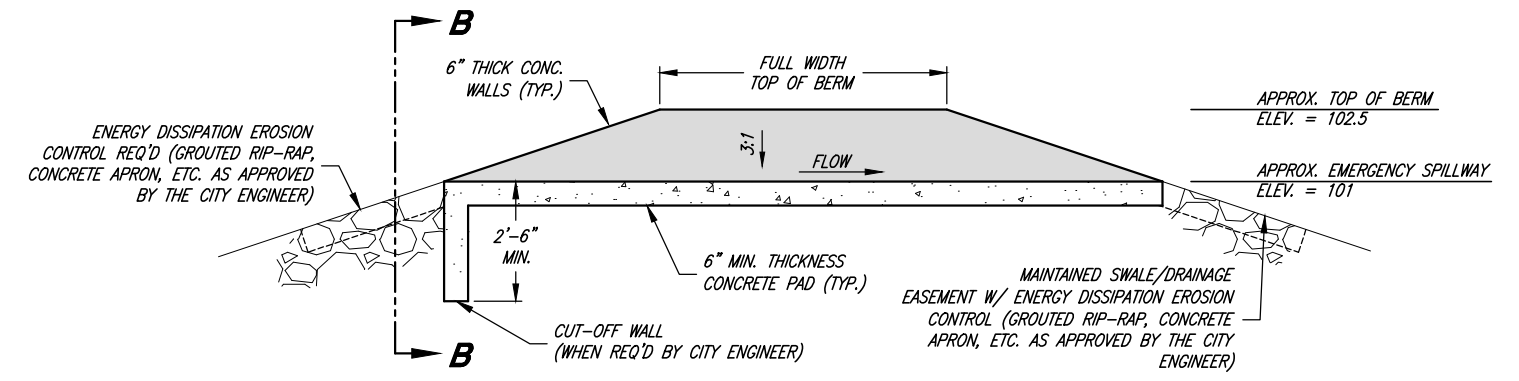

EMERGENCY OVERFLOW

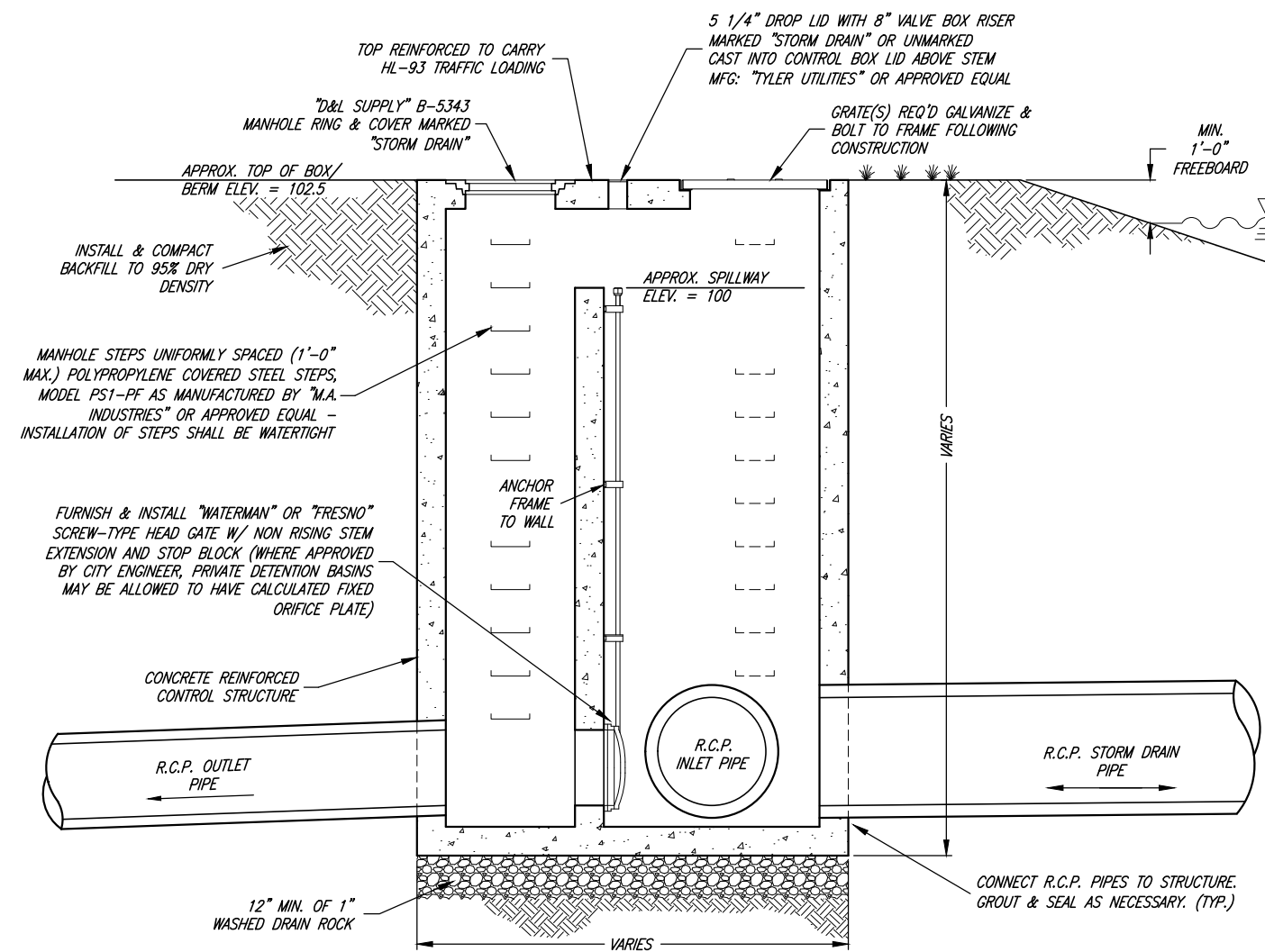

SECTION A-A

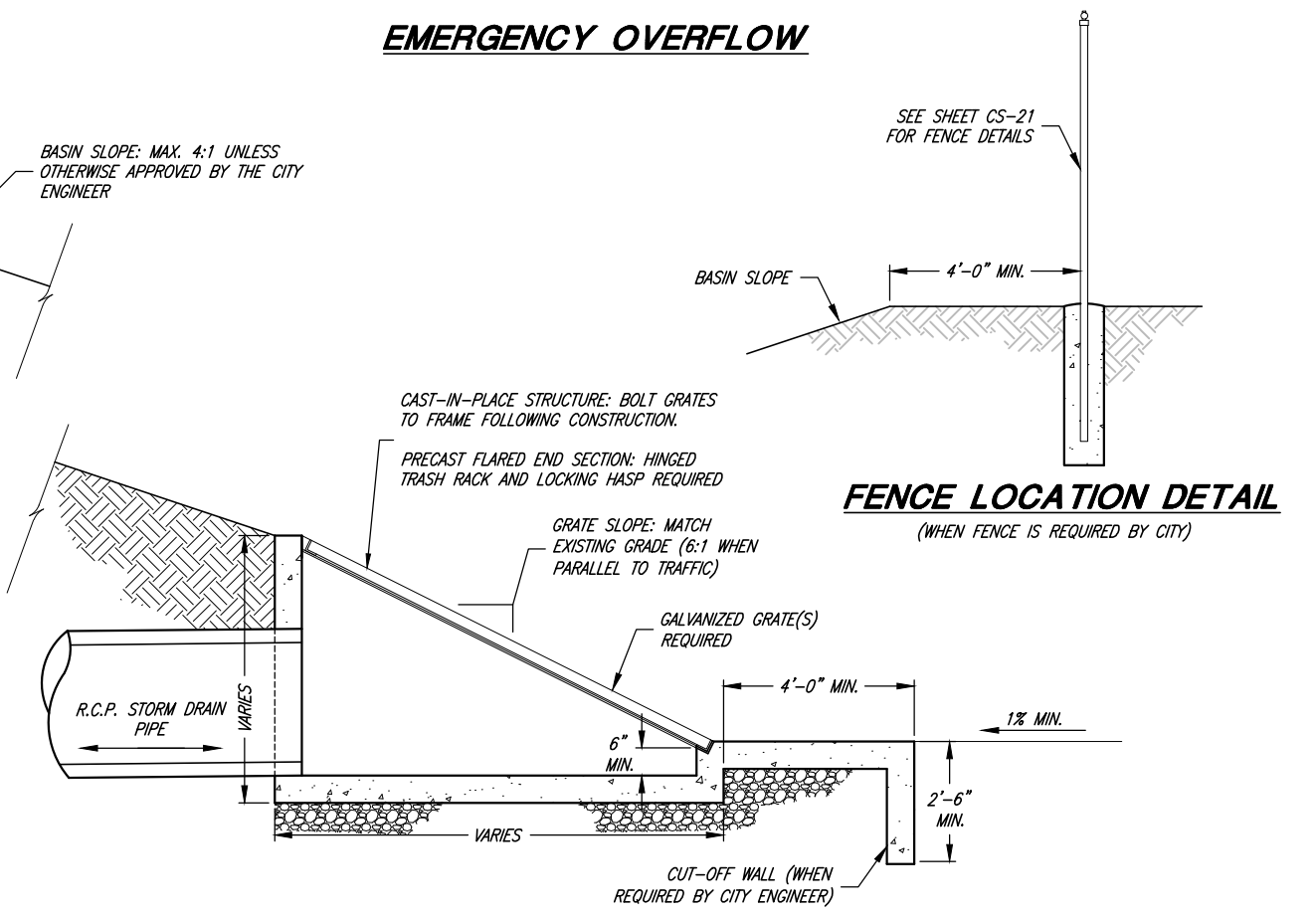

INCLINED GRATE STORM DRAIN INLET

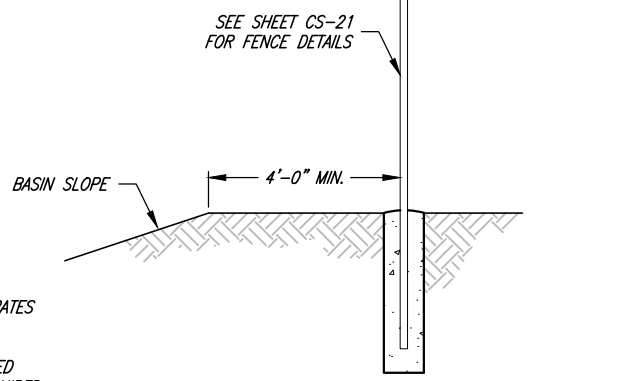

FENCE LOCATION DETAIL
(WHEN FENCE IS REQUIRED BY CITY)

GENERAL AND STRUCTURAL NOTES:
SEE SHEET CS-20

PROJECT ENGINEER	REV.	DATE	APPR.
DATE			

SCALE:	DESIGNED	BKJ
N. T.S.	DRAWN	BEB
	CHECKED	BKJ

J&A
JONES & ASSOCIATES
CONSULTING ENGINEERS
6080 Fashion Point Drive
South Ogden, Utah 84403 (801) 476-9767
www.jonescivil.com

SOUTH WEBER CITY CORPORATION
PUBLIC WORKS STANDARDS
STORM DRAIN - LARGE DETENTION BASIN DETAILS

SHEET:	CS-19
OF 23 SHEETS	0

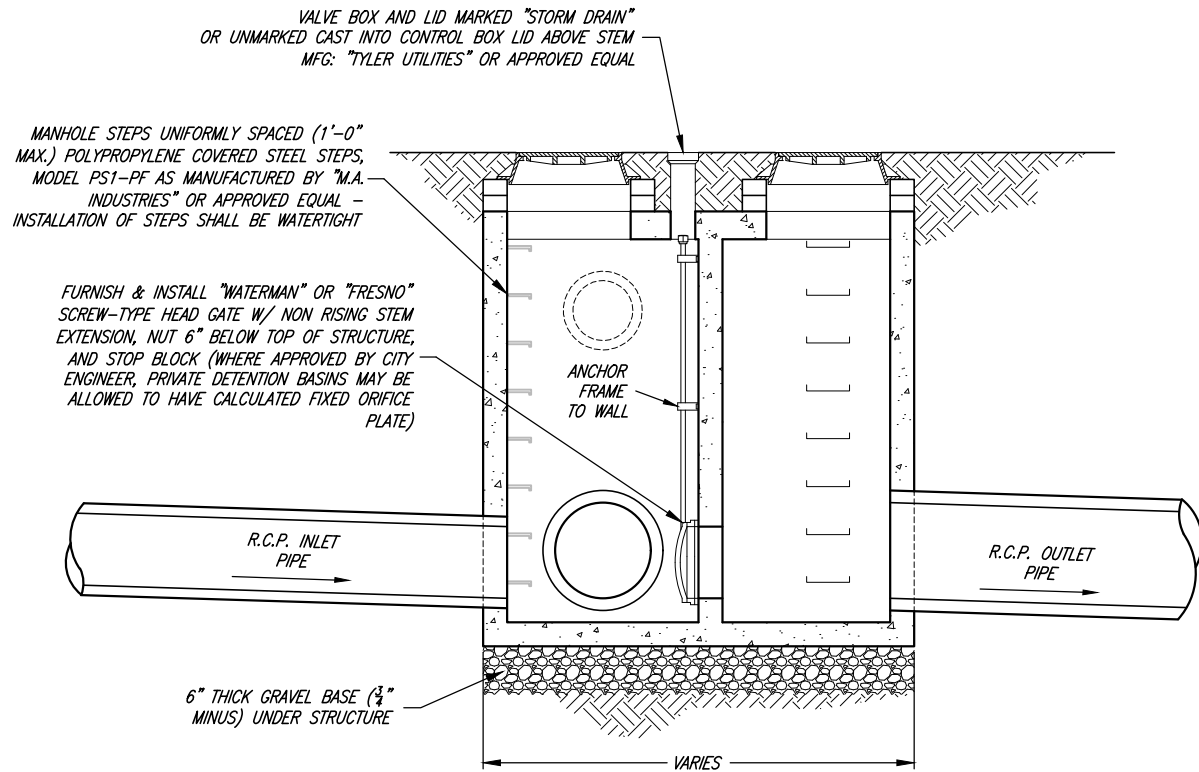

SECTION B-B

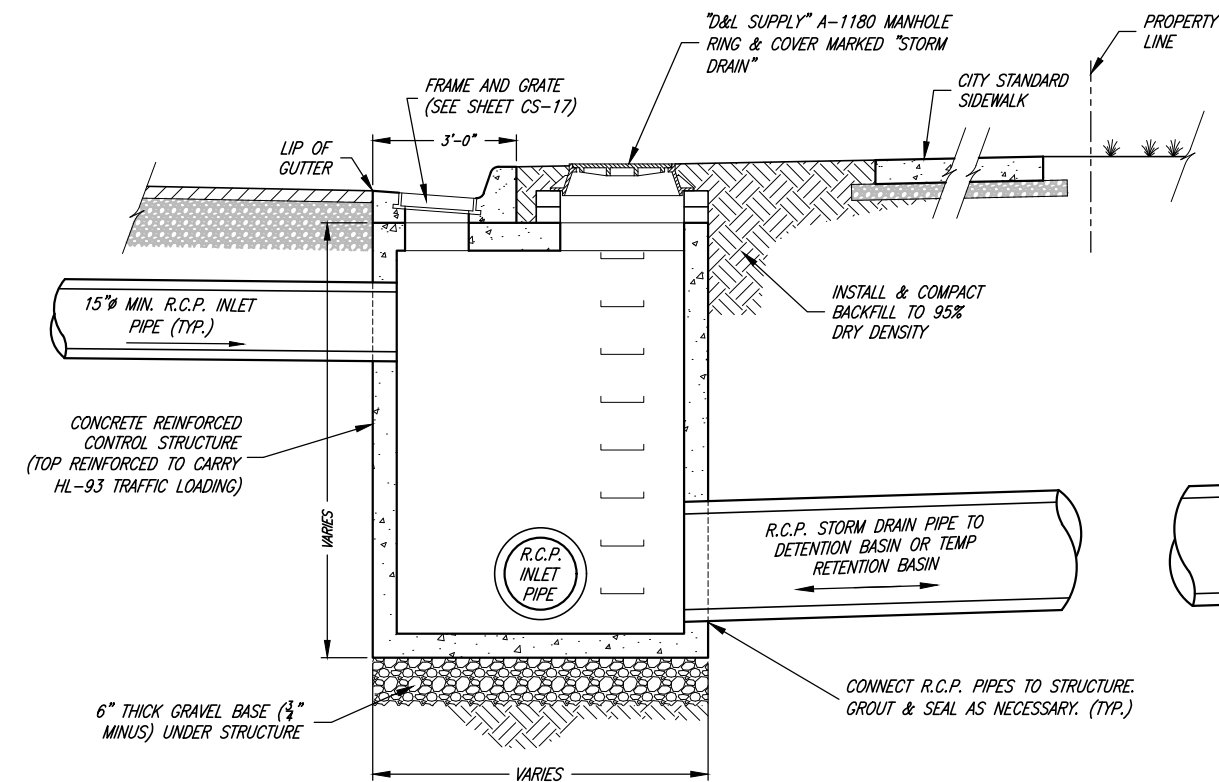

SECTION A-A

GENERAL NOTES:

1. ALL BASINS REGARDLESS OF LOCAL OR REGIONAL SHALL BE DESIGNED TO ACCOMMODATE A 100 YEAR STORM EVENT.
2. A DAM SAFETY (UTAH DIVISION OF WATER RIGHTS) HAZARD PERMIT MAY BE REQUIRED.
3. STRUCTURE DESIGN AND FLOW CALCULATIONS MUST BE APPROVED BY CITY ENGINEER PRIOR TO CONSTRUCTION.
4. STORM DRAIN LINES SHALL BE 15 INCH MINIMUM DIAMETER REINFORCED CONCRETE PIPE (RCP), OF APPROPRIATE CLASS.
5. THE SURFACE AREA OF THE BASIN SHALL BE SODDED AND SHALL BE PROVIDED WITH AN AUTOMATED SPRINKLER SYSTEM APPROVED BY THE CITY ENGINEER.
6. GRATES SHALL BE REMOVABLE FOR MAINTENANCE PURPOSES
7. GRATES SHALL BE HOT DIPPED GALVANIZED WITH BARS AT MAXIMUM 3 INCH SPACING.
8. LOW FLOWS MUST BE PIPED CONTINUOUSLY TO THE CONTROL STRUCTURE. NO OPEN FLOW IS PERMITTED THROUGH THE BASIN.
9. INCLINED GRATES ARE REQUIRED ON ALL PIPES/INLETS WHERE OPEN CHANNELS, DITCHES, OR PONDS DISCHARGE DIRECTLY INTO THE STORM DRAIN SYSTEM.
10. AN INTERNAL SPILLWAY MAY BE CONSTRUCTED INSIDE THE STRUCTURE DEPENDING ON SITE CONDITIONS AND ELEVATIONS.
11. BASIN STRUCTURES ARE DETERMINED BY THE SIZE OF THE DETENTION BASIN OR AS REQUIRED BY THE CITY ENGINEER. (SEE SHEET CS-19 OR CS-20)
 - a. SMALL DETENTION BASIN: LESS THAN OR EQUAL TO 1 ACRE FOOT
 - b. LARGE DETENTION BASIN: GREATER THAN 1 ACRE FOOT

STRUCTURAL NOTES:

- A. PRECAST CONCRETE STRUCTURE CAN BE REPLACED WITH CAST-IN-PLACE CONCRETE VAULT. SUBMIT ENGINEERED CONSTRUCTION PLANS WITH REBAR DETAILS TO CITY ENGINEER FOR REVIEW AND ACCEPTANCE PRIOR TO CONSTRUCTION.
- B. ADD REINFORCEMENT AROUND OPENINGS EQUAL TO REINFORCEMENT DISPLACED BY OPENING.
- C. THE PRECAST VAULT MANUFACTURER IS RESPONSIBLE FOR DESIGN RELATED TO TRAFFIC LOADING AND THRUST. VERIFICATION OF PROPER DESIGN MUST BE PROVIDED TO THE CITY BY THE DEVELOPER, CONTRACTOR, OR PROPERTY OWNER AS THE CASE MAY BE.
- D. REINFORCEMENT TO CONFORM WITH ASTM A 615 GRADE 60
- E. CONCRETE SHALL HAVE A 28-DAY COMPRESSIVE STRENGTH OF 5,000 PSI
- F. USE AN AIR-ENTRAINING AGENT ON ALL CONCRETE EXPOSED TO THE WEATHER.
- G. HL-93 LOADING

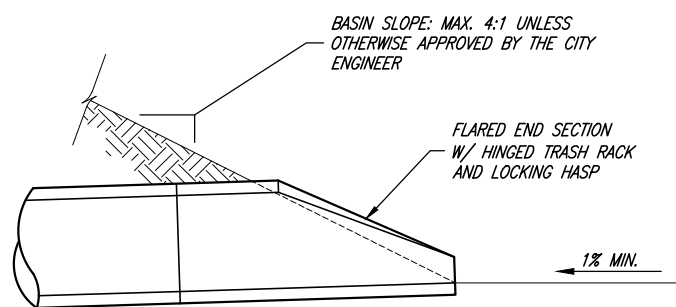

EMERGENCY OVERFLOW AND FENCE LOCATION DETAIL: SEE SHEET CS-19

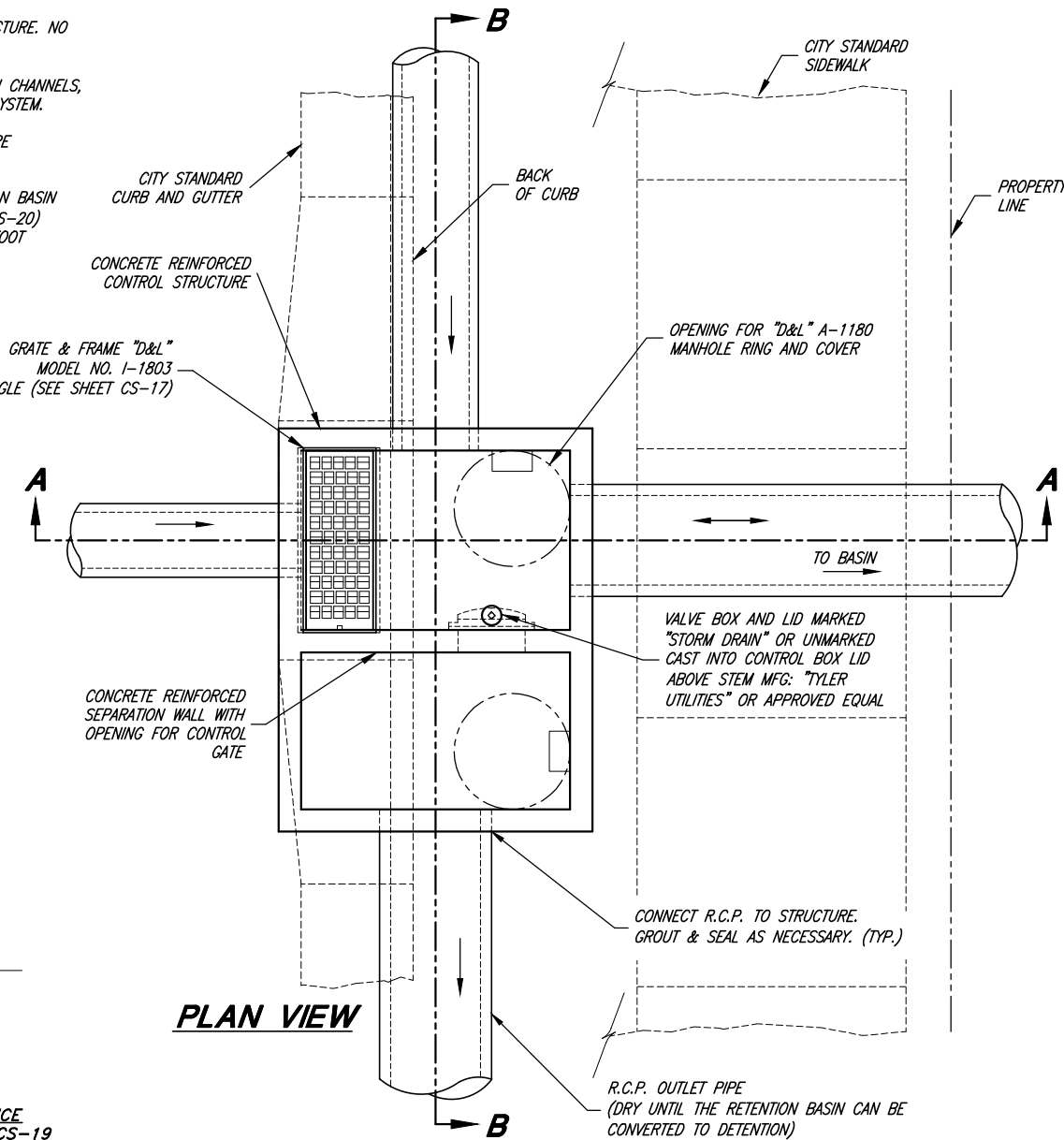

PLAN VIEW

INLET/OUTLET CONTROL STRUCTURE

(PRECAST OR CAST-IN-PLACE)

PROJECT ENGINEER	REV.	DATE	APPR.
DATE			

SCALE:

N. T.S.

DESIGNED BKJ
 DRAWN BEB
 CHECKED BKJ



CONSULTING ENGINEERS

6080 Fashion Point Drive
 South Ogden, Utah 84403 (801) 476-9767
 www.jonescivil.com

SOUTH WEBER CITY CORPORATION
PUBLIC WORKS STANDARDS

STORM DRAIN - SMALL DETENTION BASIN DETAILS

SHEET:

CS-20

OF 23 SHEETS
 0

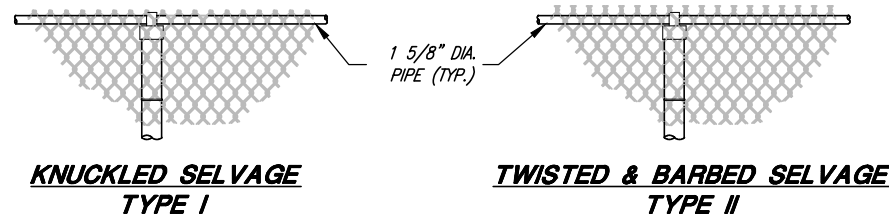

KNUCKLED SELVAGE TYPE I

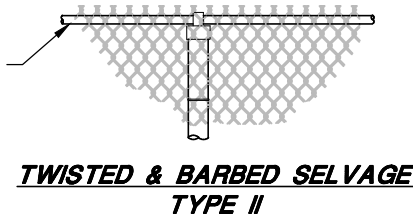

TWISTED & BARBED SELVAGE TYPE II

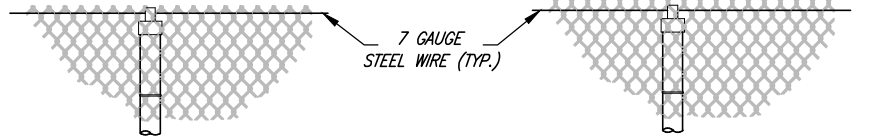

KNUCKLED SELVAGE W/ TENSION WIRE TYPE III

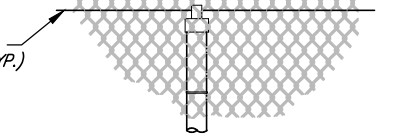

TWISTED & BARBED SELVAGE W/ TENSION WIRE TYPE IV

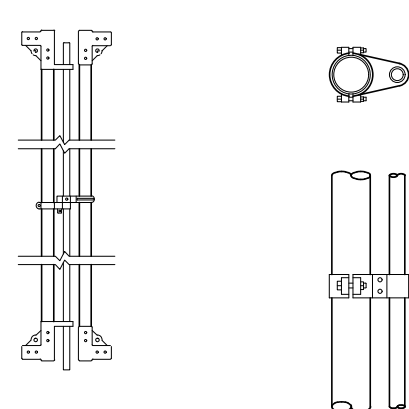

DROP ROD ASSEMBLY

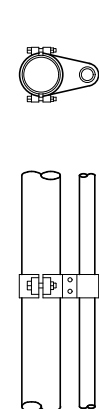

TOP GATE HINGE

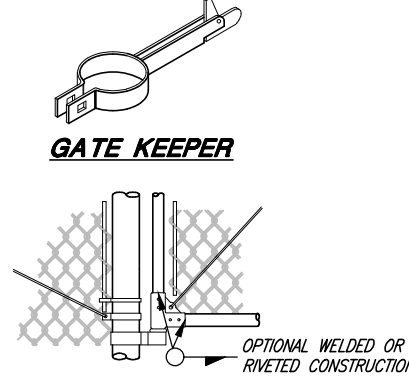

GATE KEEPER

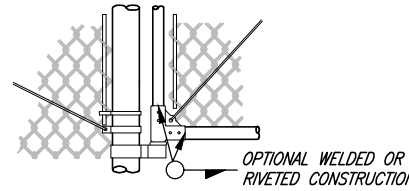

BOTTOM GATE HINGE AND GATE DETAIL

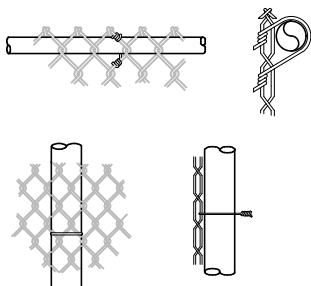

PIPE POST TIE

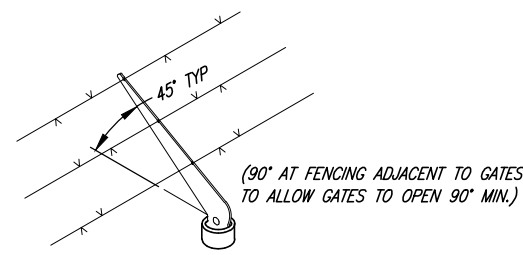

COMBINATION CAP AND BARBED WIRE SUPPORTING ARM

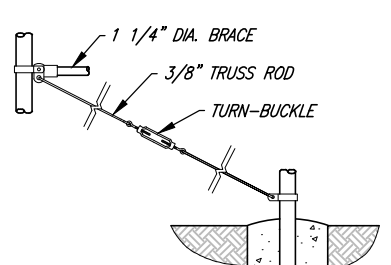

BRACE & TRUSS CONNECTIONS

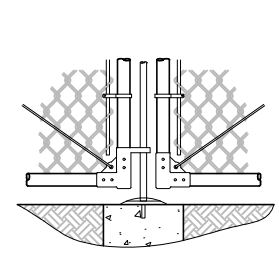

CENTER GATE STOP AND GATE DETAIL

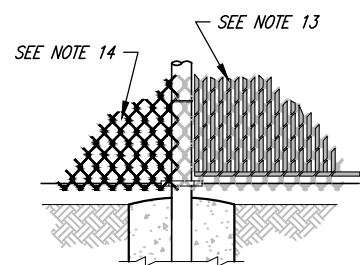

SLATS & VINYL COATING DETAIL

GENERAL NOTES:

1. MATERIALS, CONSTRUCTION, AND WORKMANSHIP SHALL BE IN ACCORDANCE WITH PROJECT STANDARD SPECIFICATIONS.
2. THE TYPE OF TOP SUPPORT IS SPECIFIED IN THE BIDDING SCHEDULE, TYPES I AND II TUBULAR RAIL, TYPES III AND IV TENSION WIRE.
3. BARB WIRE SHALL BE USED ONLY WHEN DESIGNATED ON THE PLANS OR IN THE SPECIFICATIONS.
4. TWISTED AND BARBED SELVAGE TOP AND BOTTOM SHALL BE USED ON FENCES 5- FEET HIGH OR GREATER.
5. KNUCKLED SELVAGE ON TOP AND TWISTED AND BARBED ON BOTTOM SHALL BE USED ON FENCES LESS THAN 5- FEET.
6. ALL STEEL PIPE MEMBERS SHALL CONFORM TO THE REQUIREMENTS OF ASTM DESIGNATION A 120 SCHEDULE 40 HOT DIPPED ZINC COATED HIGH TENSILE STEEL PIPE OR TRIPLE COATED PIPE MADE FROM STEEL CONFORMING TO ASTM 569.
7. POSTS SHALL BE STEEL SCHEDULE 40 PIPE OR TRIPLE COATED HIGH TENSILE STEEL PIPE OF THE SIZE SHOWN IN THE CHART. WEIGHT IN POUNDS PER FOOT WITH A TOLERANCE OF 5%.
8. LINE POSTS SHALL BE LOCATED AT EQUAL SPACING FOR EACH SEGMENT WITH A MAXIMUM SPACING AS FOLLOWS:
 - a. TANGENT SECTIONS TO 500-FOOT RADIUS NOT MORE THAN 8- FEET.
 - b. UNDER 500-FOOT RADIUS TO 200-FOOT RADIUS NOT MORE THAN 8- FEET.
 - c. UNDER 200-FOOT RADIUS TO 100-FOOT RADIUS NOT MORE THAN 6- FEET.
 - d. UNDER 100-FOOT RADIUS NOT MORE THAN 5- FEET.
9. TRUSS RODS AND BRACES SHALL NOT BE REQUIRED FOR FABRIC HEIGHT LESS THAN 5- FEET.
10. TENSION WIRE SHALL BE 7 GAUGE ZINC- OR ALUMINUM- COATED COIL SPRING STEEL TENSION WIRE.
11. ALL POSTS SHALL BE SET IN 3000 PSI CONCRETE AND SHALL BE TOPPED WITH BALL TYPE OR OTHER APPROVED ORNAMENT.
12. ALL FABRIC SHALL BE 2" GALVANIZED 9 GAUGE MESH.
13. WHITE VERTICAL SEMI- PRIVACY VINYL SLATS WITH BOTTOM- LOCKING SLAT, WHEN REQUIRED BY THE CITY.
14. BLACK VINYL COATED CHAINLINK FENCING WHEN REQUIRED BY THE CITY.
15. ALL FENCING SHALL CONFORM TO LOCATION AND HEIGHT LIMITATIONS AS STATED IN SOUTH WEBER CITY FENCING ORDINANCE.

HEIGHT	GATE OPENING	GATE POST	GATE FRAME
UNDER 6 FEET	SINGLE TO 6' OR DOUBLE TO 12'	2"	1"
	SINGLE OVER 6' TO 8' OR DOUBLE OVER 12' TO 16'	2 1/2"	
	SINGLE OVER 8' TO 12' OR DOUBLE 16' TO 24'	4"	1 1/2"
6 FEET AND OVER	SINGLE TO 6' OR DOUBLE TO 12'	3 1/2"	
	SINGLE OVER 6' TO 12' OR DOUBLE OVER 12' TO 24'	4"	1 1/2"
	SINGLE OVER 12' TO 18' OR DOUBLE OVER 24' TO 36'	6"	
	SINGLE OVER 18' OR DOUBLE OVER 36'	8"	

HEIGHT OF FABRIC	DEPTH OF POSTS	LENGTH OF END, CORNER OR PULL POST	LENGTH OF LINE POST HOLES	SIZE OF POSTS							
				END, CORNER, & PULL POSTS				LINE POST MIN. SIZE			
				NOM. SIZE	OUTSIDE DIA.	PIPE WEIGHT ASTM A-120	TRIPLE COATED	NOM. SIZE	OUTSIDE DIA.	PIPE WEIGHT ASTM A-120	TRIPLE COATED
7'	3'	10'	9'-8"	2 1/2"	2.875"	5.79	4.64	2"	2.375"	3.65	3.11
6'	3'	9'	8'-8"	2 1/2"	2.875"	5.79	4.64	2"	2.375"	3.65	3.11
5'	3'	8'	7'-8"	2"	2.375"	3.65	3.11	1 1/2"	1.900"	2.72	2.23
4'	3'	6'	5'-8"	2"	2.375"	3.65	3.11	1 1/2"	1.900"	2.72	2.23
3'	3'	5'	4'-8"	2"	2.375"	3.65	3.11	1 1/2"	1.900"	2.72	2.23

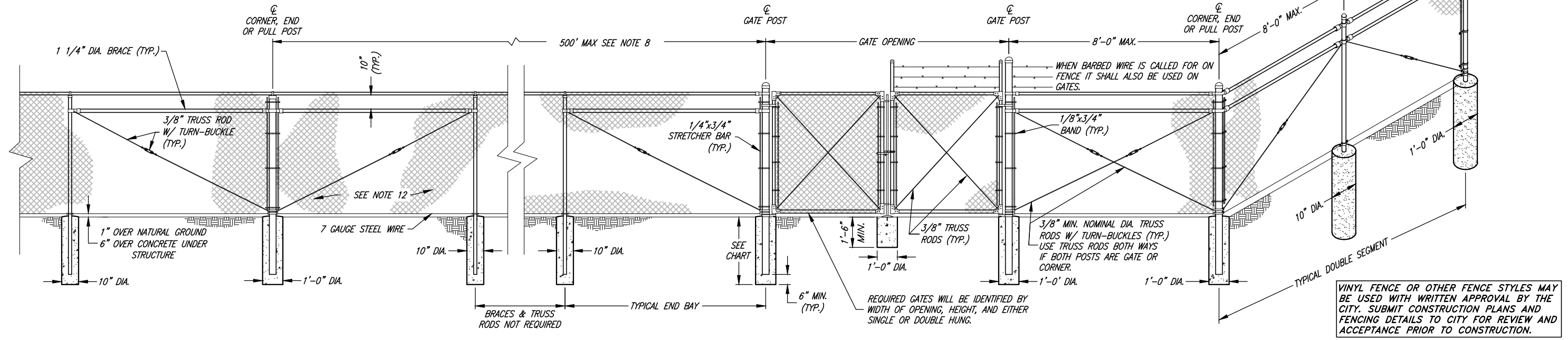

PROJECT ENGINEER	REV.	DATE	APPR.

SCALE:	DESIGNED: <i>BKJ</i>
N. T.S.	DRAWN: <i>BEB</i>
	CHECKED: <i>BKJ</i>

J&A CONSULTING ENGINEERS
 6080 Fashion Point Drive
 South Ogden, Utah 84403 (801) 476-9767
 www.jonescivil.com

SOUTH WEBER CITY CORPORATION
PUBLIC WORKS STANDARDS
GENERAL - CHAIN LINK FENCE DETAILS

ATTENTION

DEVELOPER/CONTRACTOR SHALL NOTIFY ROCKY MOUNTAIN POWER DESIGN OFFICE PRIOR TO LIGHTING INSTALLATION TO ARRANGE FOR POWER TO BE PROVIDED ON SITE, AS WELL AS APPROVAL OF LIGHTING UNIT LOCATIONS AND APPROVAL OF ACTUAL COMPONENT SELECTION.

ROCKY MOUNTAIN POWER
1-888-221-7070

ALL FINAL WORK AND MATERIALS TO BE APPROVED BY SOUTH WEBER CITY

GENERAL NOTES:

1. LIGHTS SHOWN ARE ROCKY MOUNTAIN POWER STANDARD STREET LIGHTS. STREET LIGHTS TO BE FURNISHED AND INSTALLED BY ROCKY MOUNTAIN POWER IN ACCORDANCE WITH THEIR REGULATIONS AND SPECIFICATIONS AND PAID FOR BY THE DEVELOPER/CONTRACTOR.
2. FOOTINGS TO BE INSTALLED PER MANUFACTURER/ROCKY MOUNTAIN POWER RECOMMENDATIONS. FOOTINGS SHOULD BE LOCATED WITH THE VERTICAL CENTERLINE 24" BACK FROM THE EDGE OF CURB.
3. THE DEVELOPER/CONTRACTOR MUST SUBMIT A WRITTEN REQUEST INCLUDING A MAP SHOWING THE LOCATION OF ALL STREET LIGHTS TO THE CITY. THE CITY WILL THEN SUBMIT A STREET LIGHT WORK ORDER TO ROCKY MOUNTAIN POWER.

SPACING AND LOCATION REQUIREMENTS

- A. COBRA HEAD STREET LIGHTS MUST BE LOCATED AT ALL INTERSECTIONS, CORNERS, AND CUL-DE-SACS FOR ALL STREET TYPES AT LOCATIONS SHOWN ON APPROVED CONSTRUCTION PLANS.
- B. STREET LIGHTS MUST BE SPACED AT A MAXIMUM 400 FOOT SPACING AND SHOULD ALTERNATE EACH SIDE OF THE STREET ON THE PROPERTY LINE AT LOCATIONS SHOWN ON APPROVED CONSTRUCTION PLANS.

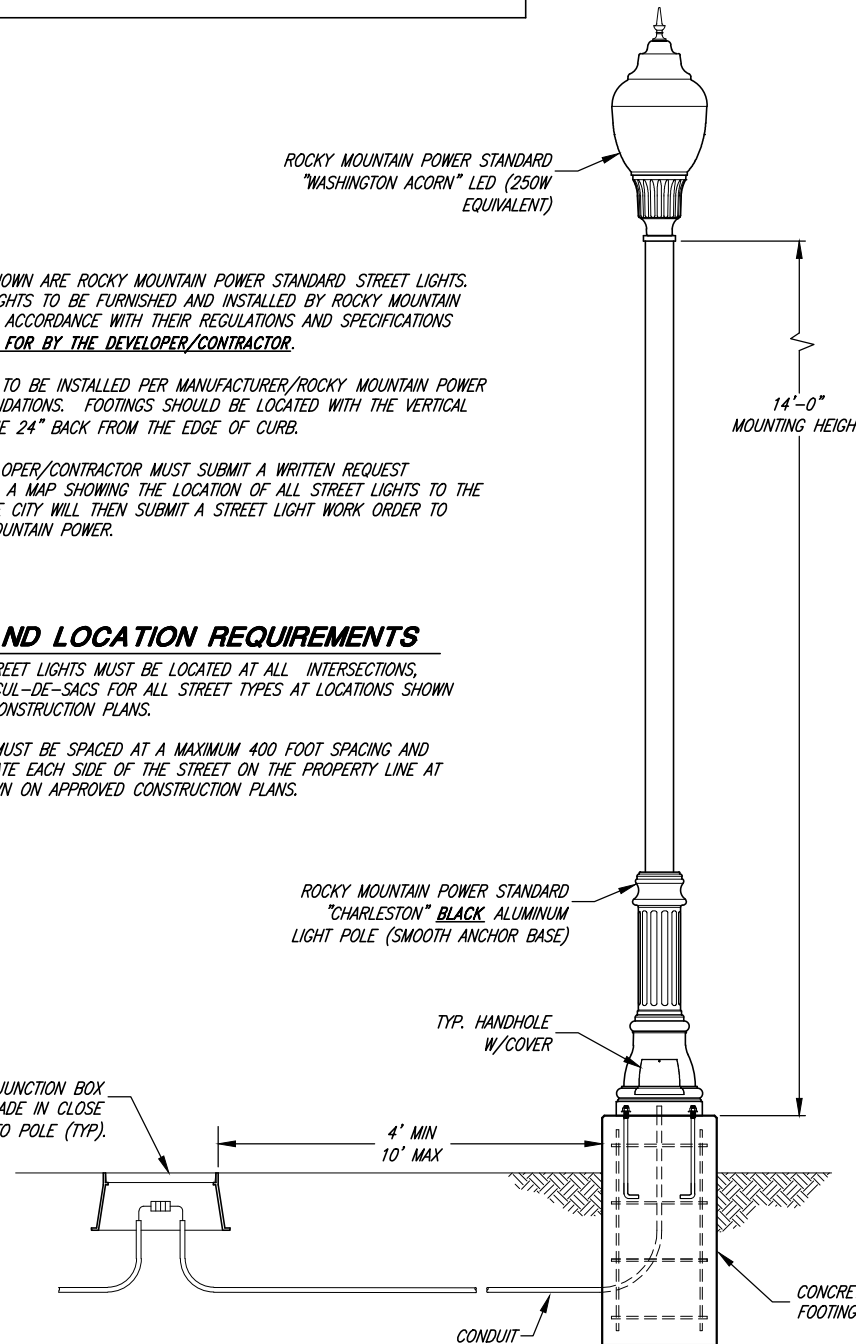
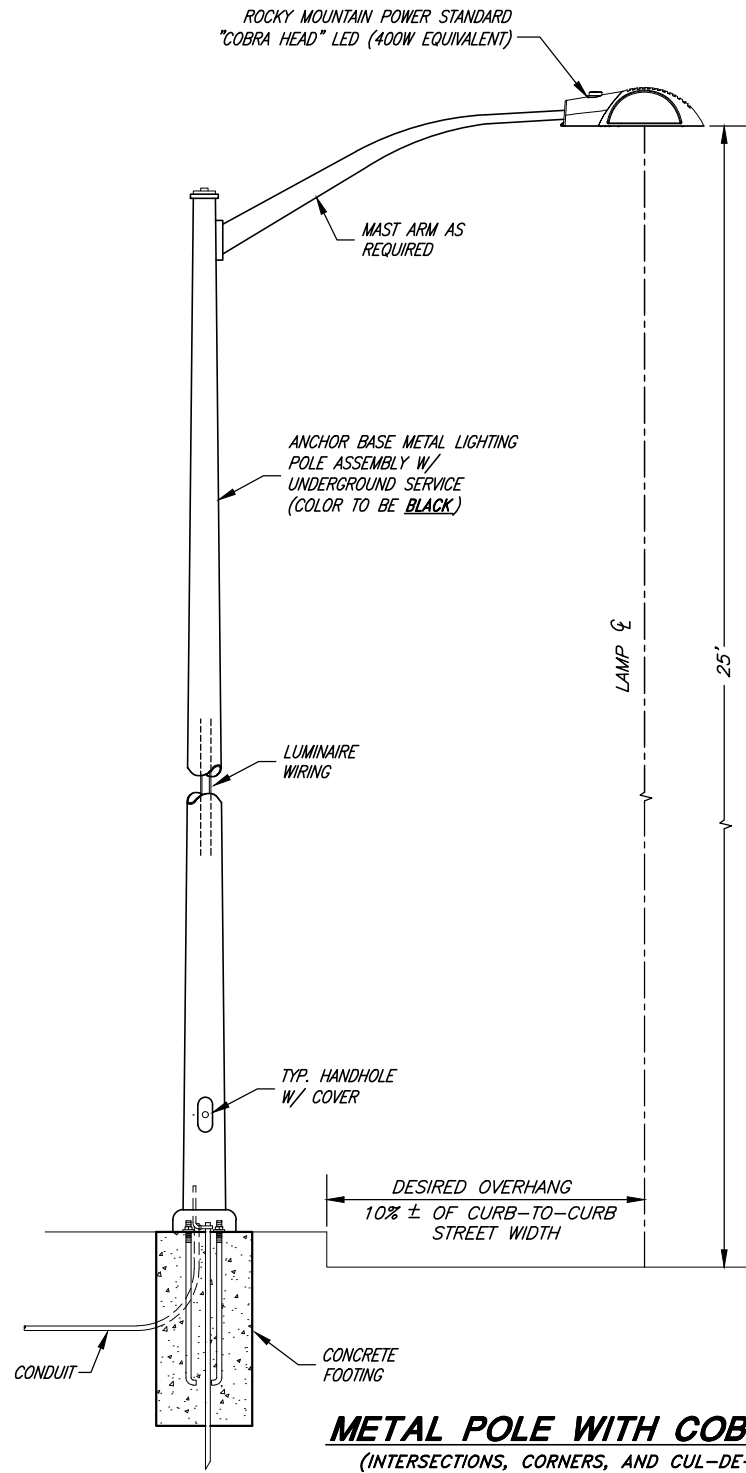

STANDARD RESIDENTIAL STREET LIGHT
(LOCAL STREETS)

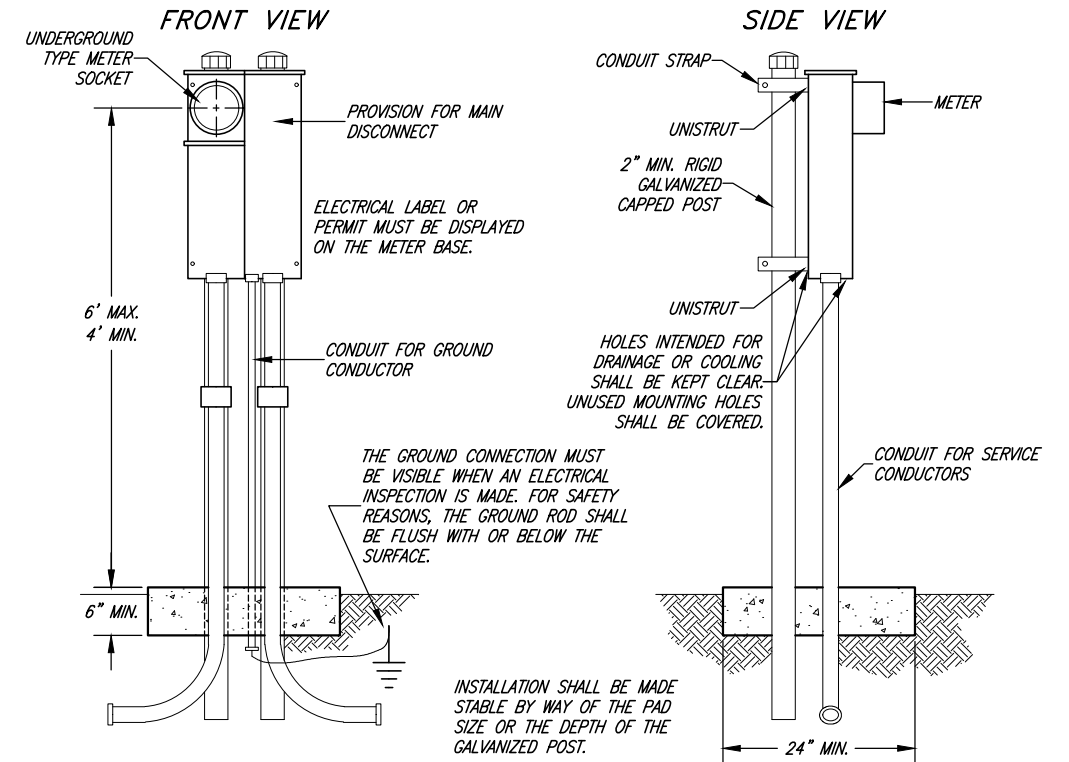

UNDERGROUND SERVICE TO A FREE-STANDING METER BASE

(STEEL POLE)

INSTALLATION PER ROCKY MOUNTAIN POWER ELECTRIC SERVICE REQUIREMENTS MANUAL

- DEVELOPER/CONTRACTOR WILL FURNISH AND INSTALL:
1. METER SOCKET ENCLOSURE (UNDERGROUND TYPE WITH MANUAL-LINK BYPASS)
 2. PEDESTAL HARDWARE
 3. CONDUIT
 4. RIGHT-OF-WAY OR EASEMENT
 5. TRENCH EXCAVATION AND BACKFILL
 6. GROUNDING PER NEC
 7. CONCRETE PAD 24" x 24" x 6" DEPTH
 8. LONG RADIUS SWEEP
 9. 36" SWEEP

FREE-STANDING METER BASE REQUIREMENTS:

1. THE DEVELOPER/CONTRACTOR SHALL MEET WITH THE POWER COMPANY TO DETERMINE THE LOCATION OF THE FREE-STANDING METER BASE.
2. THE FREE-STANDING METER BASE SHALL BE LOCATED ADJACENT TO, OR IN, THE POWER COMPANY EASEMENT.
3. THE FREE-STANDING METER BASE SHALL MEET ALL LOCAL ORDINANCE REQUIREMENTS.
4. THE METER SOCKET SHALL BE PROTECTED FROM DAMAGE BY USE OF BARRIER POSTS OR OTHER SUITABLE PROTECTION APPROVED BY THE POWER COMPANY.
5. THE DEVELOPER/CONTRACTOR SHALL FURNISH, INSTALL AND MAINTAIN AN APPROVED PEDESTAL OR POLE POST.
6. THE ACCESS DOOR TO POWER COMPANY CONNECTIONS SHALL BE KEPT FREE OF OBSTRUCTIONS A MINIMUM OF 6" ABOVE THE FINAL GRADE, WITH A SEALABLE PROVISION FOR THE POWER COMPANY.
7. THE UNMETERED SERVICE CONDUCTOR AND THE METERED SERVICE CONDUCTOR SHALL NO BE RUN IN THE SAME CONDUIT, RACEWAY, OR GUTTER.
8. THE METER SOCKET AND SERVICE EQUIPMENT SHALL BE NEMA TYPE 3R (RAINPROOF), IN GOOD CONDITION WITH NO HOLES, DENTS OR DAMAGE, AND PLUMB IN ALL DIRECTIONS. THE INSTALLATION SHALL BE MADE WITH SUFFICIENT MATERIALS AND INSTALLED SUCH THAT IT REMAINS PLUMB FOR THE DURATION OF THE SERVICE.
9. CONDUIT AND CONDUCTOR TRENCHERS SHALL BE LOCATED AWAY FROM (AND NEVER UNDERNEATH) THE PAD AND FOUNDATION. FOR MOBILE HOMES, TRENCHES SHALL BE LOCATED CLEAR OF THE AREA PROVIDED FOR THE DWELLING.
10. WHERE TWO OR MORE METERS ARE LOCATED SIDE-BY-SIDE (SUCH AS WITH DUPLEXES OR IN MOBILE HOME PARKS), THE METER SOCKET ENCLOSURE SHALL BE PERMANENTLY LABELED WITH THE SPACE OR BERTH NUMBERS.

PROJECT ENGINEER	REV.	DATE	APPR.
DATE			

SCALE:

N. T.S.

DESIGNED BKJ
DRAWN BEB
CHECKED BKJ



CONSULTING ENGINEERS
6080 Fashion Point Drive
South Ogden, Utah 84403 (801) 476-9767
www.jonescivil.com

SOUTH WEBER CITY CORPORATION
PUBLIC WORKS STANDARDS

GENERAL - STREET LIGHTING STANDARDS

SHEET:
CS-22
OF 23 SHEETS
0

ORDINANCE NO. 17-18

AN ORDINANCE OF THE SOUTH WEBER CITY COUNCIL AMENDING SOUTH WEBER CITY CODE IMPACT FEES SUBSECTIONS 11.06.010 and 11.06.040

WHEREAS, on August 22, 2017, after considering the input of the public and stakeholders and relying on the professional advice and certification of the Sewer Impact Fee Facilities Plan and Impact Fee Analysis consultants, South Weber City adopted the findings, conclusions, and recommendations of the Impact Fee Facilities Plans prepared by Jones and Associates and Impact Fee Analysis prepared by Zions Bank Public Finance Inc.; and

WHEREAS, this council finds it in the best interest of the City to amend its city code to comply with these findings;

NOW THEREFORE BE IT ORDAINED, by the Legislative Body of South Weber City:

Section 1. Subsections Amended. Subsections 11.06.010, and 11.06.040 of the South Weber City Code are hereby amended to read:

11.06.010 Adoption.

The South Weber City Council hereby approves and adopts the Impact Fee Analyses attached and the analyses reflected therein. The Impact Fee Facilities Plans and the Impact Fee Analyses, including the Weber Basin Water Conservancy Districts Treated Water Impact Fee, Sewer, and Parks and Trails are incorporated herein by reference and adopted as though fully set forth herein.

11.06.040 Impact Fees Levied.

Sewer Impact Fees.

Table 13: Maximum Fees Based on Dwelling Type or Water Meter Size

<u>Dwelling Type or Water Meter Size</u>	<u>Operating Flow</u>	<u>Ratio</u>	<u>Maximum Fee</u>
Residential:			
Apartments (3+ units per complex) – 0.75 ERU – per unit		.75	\$2,200.39
Residential (Single-Family, Duplexes, Townhomes, Condos) – 1” per unit	50	1	\$2,933.85
Non-Residential:			
Water – Commercial – 1 ½”	75	1.5	\$4,400.77
Water – Commercial – 2”	100	2	\$5,867.70
Water – Commercial – 3”	320	6.4	\$18,776.62
Water – Commercial – 4”	500	10	\$29,338.48

Section 2. Severability Clause. If a court holds any part or provision of this Ordinance invalid or unenforceable, such invalidity or unenforceability shall not affect any other portion of this Ordinance and all provisions, clauses and words of this Ordinance shall be severable.

Section 3. Effective Date. This Ordinance shall become effective November 22, 2017.

PASSED AND ADOPTED by the City Council of South Weber, Davis County, on _____ day of _____ 2017.

ATTEST:

MAYOR: Tamara Long

Mark McRae, City Recorder

Roll call vote is as follows:

Mr. Casas	Yes	No
Mr. Winsor	Yes	No
Mr. Hyer	Yes	No
Mrs. Sjoblom	Yes	No
Mr. Taylor	Yes	No

CERTIFICATE OF POSTING

I, the duly appointed recorder for the City of South Weber, hereby certify that:

***ORDINANCE 17-18: AN ORDINANCE OF THE SOUTH WEBER CITY COUNCIL
AMENDING SOUTH WEBER CITY CODE SUBSECTIONS 11.06.010 and 11.06.040***

was passed and adopted the ____ day of _____ 2017, and certifies that copies of the foregoing Ordinance 17-18 were posted in the following locations within the municipality this ____ day of _____, 2017.

1. South Weber Elementary, 1285 E. Lester Drive
2. South Weber Family Activity Center, 1181 E. Lester Drive
3. South Weber City Building, 1600 E. South Weber Drive

Mark McRae, City Recorder



South Weber City

Sewer Impact Fees Analysis

August 22, 2017

Impact Fee Analysis for Sanitary Sewer

Summary

This Impact Fees Analysis (“IFA”) uses the information provided in South Weber City’s (“City”) recently-completed (June 2017) Capital Facilities Plan and Impact Fee Facilities Plan (“IFFP”)¹ to calculate the proportionate share for impact fees that the City can charge to new development.

Growth Projections

South Weber City is projected to grow by 688 equivalent residential units (“ERUs”) between 2017 and 2027.

TABLE 1: SOUTH WEBER CITY GROWTH PROJECTIONS

Year	ERCs	Increase in ERCs from 2017 to 2027
2017	2,215	
2018	2,279	64
2019	2,345	130
2020	2,411	196
2021	2,479	264
2022	2,547	332
2023	2,616	401
2024	2,686	471
2025	2,757	542
2026	2,830	615
2027	2,903	688

Source: South Weber City, Sanitary Sewer Capital Facilities Plan and Impact Fee Facilities Plan, June 2017.

Service Areas

South Weber City forms one geographic service area that provides sewer utility services to properties in the City. The City currently has 2,215 sewer ERUs.² The City is projected to grow by 688 ERUs within the next ten years.³

¹ South Weber City, Sanitary Sewer Capital Facilities and Impact Fee Facilities, Plan, Jones & Associates, June 2017.

² South Weber City, Sanitary Sewer Capital Facilities and Impact Fee Facilities, Plan, Jones & Associates, June 2017, p.17.

³ South Weber City, Sanitary Sewer Capital Facilities and Impact Fee Facilities, Plan, Jones & Associates, June 2017, p.17.

Existing service levels are based on the 2017 levels of service in the City, as defined in the City's IFFP for Sanitary Sewer dated June 2017. Proposed service levels are intended to be the same as the existing service levels.⁴

The IFFP identified one project with excess capacity. The IFFP states, "South Weber City chose to replace and upsize part of the existing sewer trunk line along Old Fort Road." Only that portion of the project associated with the upsizing for new growth is included in the excess capacity calculation of impact fees. These costs are as follows:

TABLE 2: EXCESS CAPACITY PROJECTS

2016 Sewer Outfall Replacement Project	
Total Cost	\$626,450
Part 1 - 18" Sewer Line	
ERUs Served	770
Percent of Project	32.5%
Proportionate Share of Cost	\$203,596
Part 2 - 21" Sewer Line	
ERUs Served	1,870
Percent of Project	67.5%
Proportionate Share of Cost	\$422,854

New construction projects are outlined in this IFA as listed in the Sanitary Sewer IFFP and total \$2,004,090.

TABLE 3: NEW CONSTRUCTION PROJECTS

Project No.	Project Description	Future Development	Estimated Construction Year
1	Replace trunk line along Old Fort Road and Canyon Dr., to 1475 E	\$239,230	2018-2020
2	Replace trunk line along Canyon Dr., 1700 E, & S. Weber Dr., from 1475 E to 1900 E	\$258,300	2020-2021
4	Replace trunk line along South Weber Drive from 1900 E to 2100 E	\$258,810	2023-2026
5	Sewer line from South Bench, re-route Lester Dr. to CWSID trunk line via 7240 S	\$1,247,750	2023-2026
TOTAL		\$2,004,090	

⁴ South Weber City, *Sanitary Sewer Capital Facilities and Impact Fee Facilities, Plan*, Jones & Associates, June 2017, p.18.

Of this amount, \$1,647,492.33 can be attributed to new development between 2017 and 2027.

In addition, impact fees can include the cost of preparing the Sewer Sanitary Sewer IFFP and IFA. There is no impact fee fund balance and there is no bond outstanding. Therefore, no credits have been made for fund balance or for outstanding debt.

The proportionate share analysis for sewer impact fees is as follows:

TABLE 4: PROPORTIONATE SHARE ANALYSIS

Description	Amount
Buy-In to Excess Capacity	\$490.54
New Construction Cost	\$2,394.61
Consultant Costs	\$48.70
Maximum Fee per ERU	\$2,933.85

The maximum gross fee per ERU is \$2,933.85.

The maximum fee per ERU is then applied to the actual number of ERUs or is based on the following schedule for water meter sizes and average flow.

TABLE 5: MAXIMUM FEES BASED ON WATER METER SIZE AND RATIOS

Dwelling Type or Water Meter Size	Operating Flow	Ratio	Maximum Fee
Residential:			
Apartments (3+ units per complex)– 0.75 ERU per unit		.75	\$2,200.39
Residential (Single-Family, Duplexes, Townhomes, Condos) – 1” – per unit	50	1	\$2,933.85
Non-Residential:			
Water – Commercial – 1 ½”	75	1.5	\$4,400.77
Water – Commercial – 2”	100	2	\$5,867.70
Water – Commercial – 3”	320	6.4	\$18,776.62
Water – Commercial – 4”	500	10	\$29,338.48

Utah Code Legal Requirements

Utah law requires that communities prepare an Impact Fee Analysis (IFA) before enacting an impact fee. Utah law also requires that communities give notice of their intent to prepare and adopt an IFA. This IFA follows all legal requirements as outlined below. The City has retained Zions Public Finance, Inc. (ZPFI) to prepare this Impact Fee Analysis in accordance with legal requirements.

Notice of Intent to Prepare Impact Fee Analysis

A local political subdivision must provide written notice of its intent to prepare an IFA before preparing the Plan (Utah Code §11-36a-503). This notice must be posted on the Utah Public Notice website. The City has complied with this noticing requirement for the IFA by posting notice on

A copy of the notice is included in Appendix A.

Preparation of Impact Fee Analysis

Utah Code requires that each local political subdivision, before imposing an impact fee, prepare an impact fee analysis. (Utah Code 11-36a-304).

Section 11-36a-304 of the Utah Code outlines the requirements of an impact fee analysis which is required to:

- (1) An impact fee analysis shall:
 - (a) identify the anticipated impact on or consumption of any existing capacity of a public facility by the anticipated development activity;
 - (b) identify the anticipated impact on system improvements required by the anticipated development activity to maintain the established level of service for each public facility;
 - (c) demonstrate how the anticipated impacts described in Subsections (1)(a) and (b) are reasonably related to the anticipated development activity;
 - (d) estimate the proportionate share of:
 - (i) the costs for existing capacity that will be recouped; and
 - (ii) the costs of impacts on system improvements that are reasonably related to the new development activity; and
 - (e) identify how the impact fee was calculated.

- (2) In analyzing whether or not the proportionate share of the costs of public facilities are reasonably related to the new development activity, the local political subdivision or private entity, as the case may be, shall identify, if applicable:
 - (a) the cost of each existing public facility that has excess capacity to serve the anticipated development resulting from the new development activity;
 - (b) the cost of system improvements for each public facility;
 - (c) other than impact fees, the manner of financing for each public facility, such as user charges, special assessments, bonded indebtedness, general taxes, or federal grants;
 - (d) the relative extent to which development activity will contribute to financing the excess capacity of and system improvements for each existing public facility, by such

means as user charges, special assessments, or payment from the proceeds of general taxes;

- (e) the relative extent to which development activity will contribute to the cost of existing public facilities and system improvements in the future;
- (f) the extent to which the development activity is entitled to a credit against impact fees because the development activity will dedicate system improvements or public facilities that will offset the demand for system improvements, inside or outside the proposed development;
- (g) extraordinary costs, if any, in servicing the newly-developed properties; and
- (h) the time-price differential inherent in fair comparisons of amounts paid at different times.

Certification of Impact Fee Analysis

Utah Code states that an Impact Fee Analysis shall include a written certification from the person or entity that prepares the Impact Fee Analysis. This certification is included at the conclusion of this analysis.

Anticipated Impact On or Consumption of Any Existing Capacity of a Public Facility by the Anticipated Development Activity

Utah Code 11-36a-304(1)(a)

Anticipated Development Activity

Impacts on sewer facilities will come from both residential and nonresidential growth. Growth is projected in the IFFP as follows:

TABLE 6: ERU GROWTH

Year	ERUs	Cumulative Growth in ERUs
2017	2,215	
2018	2,279	64
2019	2,345	130
2020	2,411	196
2021	2,479	264
2022	2,547	332
2023	2,616	401
2024	2,686	471
2025	2,757	542
2026	2,830	615
2027	2,903	688
2038 (buildout)	3,770	

Demand Placed on Facilities by New Development Activity

New development between 2017 and 2027 will consume a portion of the excess capacity of Part 1 – 18” sewer line and Part 2 – 21” sewer line. The actual costs of the facilities, as well as the cost consumed by new development is shown in the following table.

TABLE 7: ACTUAL COST OF EXISTING SYSTEM AND CONSUMPTION BY NEW DEVELOPMENT 2017-2027

2016 Sewer Outfall Replacement Project	
Total Cost	\$626,450.00
Part 1 - 18" Sewer Line	
ERUs Served	770
Percent of Project	32.5%
Proportionate Share of Cost	\$203,596
Part 2 - 21" Sewer Line	
ERUs Served	1,870
Percent of Project	67.5%
Proportionate Share of Cost	\$422,854

Identify the Anticipated Impact on System Improvements Required by the Anticipated Development Activity to Maintain the Established Level of Service for Each Public Facility and Demonstrate How the Anticipated Impacts are Reasonably Related to the New Development Activity

Utah Code 11-36a-304(1)(b)(c)

The IFFP identifies the new projects needed to meet the demand on the sewer system by the anticipated development activity. The projects needed between 2017 and 2027 total \$1,647,492.33.

TABLE 8: NEW CONSTRUCTION PROJECTS

Project No.	Project Description	Future Development	Estimated Construction Year	ERUs Served	% to New Development, 2017-2027	Cost to New Development, 2017-2027
1	Replace trunk line along Old Fort Road and Canyon Dr., to 1475 E	\$239,230	2018-2020	854	81%	\$192,728.62
2	Replace trunk line along Canyon Dr., 1700 E, & S. Weber Dr., from 1475 E to 1900 E	\$258,300	2020-2021	854	81%	\$208,091.80
4	Replace trunk line along South Weber Drive from 1900 E to 2100 E	\$258,810	2023-2026	266	100%	\$258,810.00
5	Sewer line from South Bench, re-route Lester Dr. to CWSID trunk line via 7240 S	\$1,247,750	2023-2026	869	79%	\$987,861.91
TOTAL		\$2,004,090				\$1,647,492.33

Proportionate Share Analysis

The proportionate share analysis is calculated by taking five components of the impact fees:

- 1) Buy-in to the actual costs of existing, excess capacity;
- 2) Proportionate share of the cost of constructing new facilities;
- 3) Consultant costs associated with the sewer impact fees;
- 4) Credits for any impact fee fund balance; and
- 5) Credits for any payments to be made on any outstanding bonds.

Excess Capacity Calculation.

The excess capacity calculation is calculated by taking the actual cost of the existing facilities and multiplying by the percentage of excess capacity and then dividing by the total number of ERUs served.

TABLE 9: PROPORTIONATE SHARE CALCULATION FOR EXISTING, EXCESS CAPACITY

2016 Sewer Outfall Replacement Project	
Total Cost	\$626,450.00
Part 1 - 18" Sewer Line	
ERUs Served	770
Percent of Project	32.5%
Proportionate Share of Cost	\$203,596
Cost per ERU	\$264.41
Part 2 - 21" Sewer Line	
ERUs Served	1,870
Percent of Project	67.5%
Proportionate Share of Cost	\$422,854
Cost per ERU	\$226.13

This results in a total buy-in cost of \$490.54 per ERU.

New Construction Calculation.

The proportionate fee for the construction of new facilities is calculated by taking the cost attributable to new development over the next ten years (\$1,647,492.33) and dividing by the growth in ERUs over that same time period (688 ERUs).

TABLE 10: PROPORTIONATE SHARE CALCULATION FOR NEW FACILITIES

NEW CONSTRUCTION	Amount
New Construction Cost	\$2,004,090
Cost Attributable to New Development, 2017-2027	\$1,647,492.33
Growth in ERUs, 2017-2027	688
New Construction Cost per ERU	\$2,394.61

Consultant Costs.

The costs incurred by the consultants in preparing the IFFP and IFA can be included as part of the impact fees calculation. These costs are shown below.

TABLE 11: PROPORTIONATE SHARE CALCULATION FOR CONSULTANT COSTS

Description	Amount
Jones & Associates	\$30,506.25
ZPFI	\$3,000.00
Total Consultant Costs	\$33,506.25
Consultant Cost per ERU	\$48.70

Impact Fee Fund Balance.

There is currently no impact fee fund balance.

Summary of Impact Fees

The maximum gross impact fee that can be charged is \$2,933.85 per ERU.

TABLE 12: SUMMARY OF PROPORTIONATE SHARE CALCULATION

Description	Amount
Buy-In to Excess Capacity	\$490.54
New Construction Cost	\$2,394.61
Consultant Costs	\$48.70
Total Cost per ERU	\$2,933.85

The maximum fee per ERU is then applied to the actual number of ERUs or is based on the following schedule for water meter sizes and average flow.

TABLE 13: MAXIMUM FEES BASED ON WATER METER SIZE AND RATIOS

Dwelling Type or Water Meter Size	Operating Flow	Ratio	Maximum Fee
Residential:			
Apartments (3+ units per complex)– 0.75 ERU – per unit		.75	\$2,200.39
Residential (Single-Family, Duplexes, Townhomes, Condos) – 1” – per unit	50	1	\$2,933.85
Non-Residential:			
Water – Commercial – 1 ½”	75	1.5	\$4,400.77
Water – Commercial – 2”	100	2	\$5,867.70
Water – Commercial – 3”	320	6.4	\$18,776.62
Water – Commercial – 4”	500	10	\$29,338.48

Calculation of Credits for Outstanding Debt

There is no outstanding debt and therefore no credits need to be made.

Certification

Zions Public Finance, Inc. certifies that the attached impact fee analysis:

1. Includes only the costs of public facilities that are:
 - a. allowed under the Impact Fees Act; and
 - b. actually incurred; or
 - c. projected to be incurred or encumbered within six years after the day on which each impact fee is paid;

2. Does not include:
 - a. costs of operation and maintenance of public facilities;
 - b. costs for qualifying public facilities that will raise the level of service for the facilities, through impact fees, above the level of service that is supported by existing residents;
or
 - c. an expense for overhead, unless the expense is calculated pursuant to a methodology that is consistent with generally accepted cost accounting practices and the methodological standards set forth by the federal Office of Management and Budget for federal grant reimbursement;

3. Offsets costs with grants or other alternate sources of payment; and

4. Complies in each and every relevant respect with the Impact Fees Act.

Appendix A - Notice of Intent to Prepare Sewer Impact Fee Analysis Utah Public Notice

Documents Updated

- [IFFP Intent.pdf - 1/30/17 2:21 PM](#)

City Council

[*Notice of intent to prepare an impact facilities plan*](#)

Notice Date & Time: 2/7/17 5:00 PM

Description/Agenda:

Pursuant to the requirements of Utah Code Ann. 11-36a-501 and 11-36a-503, notice is hereby given of South Weber City's to contract to prepare or amend Impact Fee Facilities Plans and Impact Fee Written Analysis for culinary water, sewer, storm water, streets, parks and trails, fire, and public safety. The geographical area where the proposed impact fee facilities will be located is the entire City limits.

Notice of Special Accommodations:

N/A

Notice of Electronic or telephone participation:

N/A

Other information:

Location:

1600 E. South Weber Dr., South Weber, 84405

Contact information:

Tom Smith, tsmith@southwebercity.com, 8014793177

ORDINANCE NO. 17-19

AN ORDINANCE OF THE SOUTH WEBER CITY COUNCIL AMENDING SOUTH WEBER CITY CODE IMPACT FEES SUBSECTIONS 11.06.010 and 11.06.040

WHEREAS, on September 19, 2017, after considering the input of the public and stakeholders and relying on the professional advice and certification of the Parks and Trails Impact Fee Facilities Plan and Impact Fee Analysis Consultants, South Weber City adopted the findings, conclusions, and recommendations of the Impact Fee Facilities Plans and Impact Fee Analysis prepared by Zions Bank Public Finance Inc.; and

WHEREAS, this council finds it in the best interest of the City to amend its city code to comply with these findings;

NOW THEREFORE BE IT ORDAINED, by the Legislative Body of South Weber City:

Section 1. Subsections Amended. Subsections 11.06.010, and 11.06.040 of the South Weber City Code are hereby amended to read:

11.06.010 Adoption.

The South Weber City Council hereby approves and adopts the Impact Fee Analyses attached and the analyses reflected therein. The Impact Fee Facilities Plans and the Impact Fee Analyses, including the Weber Basin Water Conservancy Districts Treated Water Impact Fee, and Parks and Trails are incorporated herein by reference and adopted as though fully set forth herein.

11.06.040 Impact Fees Levied.

Parks and Trails Impact Fees.

The total maximum fee that can be charged is \$582.39 per capita. However, the actual fee charged will be based on a residential unit.

Table 5: Summary of Parks & Trails Gross Impact Fee Per Residential Unit

Category	Household Size	Calculation per Capita
Single-Family Residential	3.6	\$2,096.62
Multi-Family Residential	3.54	\$2,061.66
Non-Residential		No Fee

Section 2. Severability Clause. If a court holds any part or provision of this Ordinance invalid or unenforceable, such invalidity or unenforceability shall not affect any other portion of this Ordinance and all provisions, clauses and words of this Ordinance shall be severable.

Section 3. Effective Date. This Ordinance shall become effective December 19, 2017.

PASSED AND ADOPTED by the City Council of South Weber, Davis County, on _____ day of _____ 2017.

ATTEST:

MAYOR: Tamara Long

Mark McRae, City Recorder

Roll call vote is as follows:

Mr. Casas	Yes	No
Mr. Winsor	Yes	No
Mr. Hyer	Yes	No
Mrs. Sjoblom	Yes	No
Mr. Taylor	Yes	No

CERTIFICATE OF POSTING

I, the duly appointed recorder for the City of South Weber, hereby certify that:

***ORDINANCE 17-18: AN ORDINANCE OF THE SOUTH WEBER CITY COUNCIL
AMENDING SOUTH WEBER CITY CODE SUBSECTIONS 11.06.010 and 11.06.040***

was passed and adopted the ____ day of _____ 2017, and certifies that copies of the foregoing Ordinance 17-19 were posted in the following locations within the municipality this ____ day of _____, 2017.

1. South Weber Elementary, 1285 E. Lester Drive
2. South Weber Family Activity Center, 1181 E. Lester Drive
3. South Weber City Building, 1600 E. South Weber Drive

Mark McRae, City Recorder



South Weber City

Parks and Trails Impact Fee Analysis

September 2017



Table of Contents

Summary of Impact Fee Analysis (IFA)	3
Utah Code 11-36a	7
Impact Fee Analysis	9
Impact on Consumption of Existing Capacity	9
Impact on System Improvements by Anticipated Development.....	12
Relationship of Anticipated Impacts to Anticipated Development	15
Proportionate Share Analysis.....	15
Impact Fee Credits	17
Manner of Financing	18
Certification	19
Appendix A – Notice of Intent to Prepare an Impact Fee Analysis	20

Summary of Impact Fee Analysis (IFA)

Utah Code allows cities to include only system-wide parks for the purpose of calculating impact fees. Project-wide parks cannot be used to establish levels of service eligible to be maintained through impact fees. Based on input from South Weber City and the consultants, a system-wide park is defined as a park that serves more than one local development area. After consideration, the City has determined that there is one geographic service area citywide for the purpose of providing parks and recreation services and facilities.

This IFA is organized based on the legal requirements of Utah Code 11-36a-304.

Impact on Consumption of Existing Capacity - *Utah Code 11-36a-304(1)(a)*

South Weber City has a 2017 population of 7,462 persons. The City's population is projected to add 2,075 residents between 2017 and 2026, growing to 9,537 residents by 2026.

Existing and proposed service levels are shown in the table below on both a *unit* and *cost* basis.

TABLE 1: SUMMARY OF EXISTING SERVICE LEVELS, PROPOSED SERVICE LEVELS AND EXCESS CAPACITY

	Existing	Proposed	Excess Capacity	Existing	Proposed	Excess Capacity
Land (acres per 1,000 population; cost per capita)	1.8	1.8	-	\$193.81	\$193.81	\$0.00
Park Improvements (cost per capita)				\$180.16	\$180.16	\$0.00
Park Mowed Acres (acres per 1,000 population; cost per capita)	2.26	2.26	-	\$158.36	\$158.36	\$0.00
Park Parking (asphalt acres per 1,000 population; cost per capita)	0.19	0.19	-	\$24.38	\$24.38	\$0.00
Trails (linear feet per capita; cost per capita)	0.48	0.48	-	\$19.16	\$19.16	\$0.00
Trailheads (trailheads per 1,000 population; cost per capita)	0.40	0.40	-	\$20.10	\$20.10	\$0.00

Impact on System Improvements by Anticipated Development Activity - *Utah Code 11-36a-304(1)(b)*

The table below shows the declining service levels that will occur in South Weber, due to population growth, if no new facilities are added. Service levels are shown in terms of units and in terms of cost. Each of these declining service levels is discussed in more detail in the body of this report.

TABLE 2: IMPACTS TO SERVICE LEVELS DUE TO NEW DEVELOPMENT IF NO IMPROVEMENTS ARE MADE

Summary Table	UNITS		COST	
	2017	2026	2017	2026
Land (acres per 1,000 population; cost per capita)	1.85	1.45	\$193.81	\$151.64
Park Improvements (cost per capita)			\$180.16	\$140.96

Summary Table	UNITS		COST	
	2017	2026	2017	2026
Park Mowed Acres (acres per 1,000 population; cost per capita)	2.26	1.77	\$158.36	\$123.91
Parking (asphalt acres per 1,000 population; cost per capita)	0.19	0.15	\$24.38	\$19.07
Trails (trail linear feet per capita; cost per capita)	0.48	0.37	\$19.16	\$14.99
Trailheads (trailheads per 1,000 population; cost per capita)	0.402	0.315	\$20.10	\$15.73

The City will need to acquire additional park land, park improvements, mowed acres and parking spaces in order to maintain its existing service levels and to reach its proposed level of service through 2026. Park service levels will decline, as a result of population growth, unless new park improvements are constructed or acquired.

Park land can be acquired for an estimated cost of \$104,926 per acre;¹ park improvements will cost \$180.16 per capita; mowed acres will cost roughly \$70,131.60 per acre (based on a cost of \$1.61 per square foot for sod and irrigation); parking costs are estimated at \$2.88 per square foot, or \$125,452.80 per acre; trails cost \$40.00 per linear foot; and trailheads (given the existing condition) average \$50,000 each.

The City will need to spend the following amounts just to maintain existing service levels.

TABLE 3: SUMMARY OF PARK IMPROVEMENT COSTS NECESSITATED BY NEW DEVELOPMENT, 2017 – 2026

Summary of Park Improvements Needed, 2017-2026	
Park Land	\$402,152
Park Improvements	\$373,826
Park Mowed Acres	\$328,607
Parking Areas	\$50,584
Trails	\$39,754
Trailheads	\$41,711
TOTAL	\$1,236,634

Relationship of Anticipated Impacts to Anticipated Development Activity - Utah Code 11-36a-304(1)(c)

The demand placed on existing public park facilities by new development activity is attributable to population growth. South Weber City has a 2017 population of 7,462 persons and as a result of anticipated development activity will grow to a projected 9,537 persons by 2026 – an increase of 2,075 persons. As growth occurs as a result of increased development activity, more parks and trails are needed to maintain existing service levels and to reach proposed service levels.

¹ Costs were taken from the 2016 purchase of Old Maple Farms.

Proportionate Share Analysis - Utah Code 11-36a-304(1)(d)(i)(ii)

Costs Reasonably Related to New Development Activity

The cost of new system improvements required to maintain the service levels related to new development activity are based on the costs of system-wide park facilities, and the consultant fees for the preparation of the Impact Fee Facilities Plan and the Impact Fee Analysis.

The total maximum fee that can be charged is \$582.39 per capita. However, the actual fee charged will be based on a residential unit.

TABLE 4: CALCULATION OF GROSS IMPACT FEE PER CAPITA

Summary	
Land	\$193.81
Park Improvements	\$180.16
Mowed Acres	\$158.36
Parking Areas	\$24.38
Trails	\$19.16
Trail Structures	\$20.10
Consultant Costs	\$3.90
Credit for Impact Fee Fund Balance	(\$17.48)
TOTAL	\$582.39

The City may choose to either charge one fee for every type of residential unit, or it can charge different fees for single-family and multi-family units. The average household size for a residential unit in South Weber is 3.54 persons² when both single-family and multi-family units are combined. However, impact fees are usually charged based on single-family residential units and multi-family residential units. Therefore, maximum fees for single-family residential units are somewhat higher than the maximum fees for multi-family units due to their larger household sizes.

TABLE 5: CALCULATION OF GROSS IMPACT FEE PER RESIDENTIAL UNIT

Single-Family Residential	3.6	\$2,096.62
Multi-Family Residential	3.54	\$1,787.95
Non-Residential Development		No Fee

Source: United States Census 2010; <https://factfinder.census.gov/faces/tableservices/jsf/pages/productview.xhtml?src=CF>

The maximum impact fee that can be charged is therefore \$2,096.62 per single-family residential unit and \$1,787.95 per multi-family unit. No impact fees for parks, trails and recreation are charged to non-residential development.

Manner of Financing - Utah Code 11-36a-304(2)(c)(d)(e)(f)(g)(h)

An impact fee is a one-time fee that is implemented by a local government on new development to help fund and pay for all or a portion of the costs of public facilities that are needed to serve new development. Additionally, impact fees allow new growth to share in the cost of existing facilities that have excess capacity.

² Source: United States Census 2010.

Impact Fee Credits

The Impact Fees Act requires credits to be paid back to development for future fees that may be paid to fund system improvements found in the IFFP so that new development is not charged twice. These credits have been calculated for the outstanding bond and the outstanding note for property purchase.

Extraordinary Costs and Time Price Differential

It is not anticipated that there will be any extraordinary costs in servicing newly-developed park properties.

Utah Code 11-36a

Preparation of Impact Fee Analysis. Utah Code requires that “each local political subdivision... intending to impose an impact fee shall prepare a written analysis (Impact Fee Analysis or IFA) of each impact fee” (Utah Code 11-36a-303). This IFA follows all legal requirements as outlined below. South Weber City has retained Zions Public Finance, Inc. (ZPFI) to prepare this Impact Fee Analysis in accordance with legal requirements.

Section 11-36a-304 of the Utah Code outlines the requirements of an impact fee analysis which is required to identify the following:

- anticipated impact on or consumption of any existing capacity of a public facility by the anticipated development activity;
- anticipated impact on system improvements required by the anticipated development activity to maintain the established level of service for each public facility;
- how anticipated impacts are reasonably related to the anticipated development activity
- the proportionate share of:
 - costs for existing capacity that will be recouped; and
 - costs of impacts on system improvement that are reasonably related to the new development activity; and
- how the impact fee was calculated

Further, in analyzing whether or not the proportionate share of the costs of public facilities are reasonably related to the new development activity, the local political subdivision or private entity, as the case may be, shall identify, if applicable:

- the cost of each existing public facility that has excess capacity to serve the anticipated development resulting from the new development activity;
- the cost of system improvements for each public facility;
- other than impact fees, the manner of financing for each public facility such as user charges, special assessments, bonded indebtedness, general taxes, or federal grants;
- the relative extent to which development activity will contribute to financing the excess capacity of and system improvements for each existing public facility, by means such as user charges, special assessments, or payment from the proceeds of general taxes;
- the relative extent to which development activity will contribute to the cost of existing public facilities and system improvements in the future;
- the extent to which the development activity is entitled to a credit against impact fees because the development activity will dedicate system improvements or public facilities that will offset the demand for system improvements, inside or outside the proposed development;
- extraordinary costs, if any in servicing the newly developed properties; and
- the time-price differential inherent in fair comparisons of amounts paid at different times.

Calculating Impact Fees. Utah Code 11-36a-305 states that for purposes of calculating an impact fee, a local political subdivision or private entity may include the following:

- construction contract price;
- cost of acquiring land, improvements, materials, and fixtures;

- cost for planning, surveying, and engineering fees for services provided for and directly related to the construction of the system improvements; and
- for a political subdivision, debt service charges if the political subdivision might use impact fees as a revenue stream to pay the principal and interest on bonds, notes or other obligations issued to finance the costs of the system improvements.

Additionally, the Code states that each political subdivision or private entity shall base impact fee amounts on realistic estimates and the assumptions underlying those estimates shall be disclosed in the impact fee analysis.

Certification of Impact Fee Analysis. Utah Code 11-36a-306 states that an impact fee analysis shall include a written certification from the person or entity that prepares the impact fee analysis. This certification is included at the conclusion of this analysis.

Impact Fee Enactment. Utah Code 11-36a-202 states that a local political subdivision or private entity wishing to impose impact fees shall pass an impact fee enactment in accordance with Section 11-36a-402. Additionally, an impact fee imposed by an impact fee enactment may not exceed the highest fee justified by the impact fee analysts. An impact fee enactment may not take effect until 90 days after the day on which the impact fee enactment is approved.

Notice of Intent to Prepare Impact Fee Analysis. A local political subdivision must provide written notice of its intent to prepare an IFA before preparing the Analysis (Utah Code 11-36a-503(1)). This notice must be posted on the Utah Public Notice website. South Weber City has complied with this noticing requirement for the IFA by posting notice on February 7, 2017. A copy of the notice is included in Appendix A.

Impact Fee Analysis

Utah Code allows cities to include only system-wide parks for the purpose of calculating impact fees. Project-wide parks cannot be used to establish levels of service eligible to be maintained through impact fees. Based on input from the South Weber City and the consultants, a system-wide park is defined as a park that serves more than one local development area.

This IFA is organized based on the legal requirements of Utah Code 11-36a-304.

1 Impact on Consumption of Existing Capacity

Utah Code 11-36a-304(1)(a): an impact fee analysis shall identify the anticipated impact on or consumption of any existing capacity of a public facility by the anticipated development activity

Park Land. Existing park service levels will decline, due to new development activity, from the existing service level of \$193.81 per capita to \$151.64 per capita by 2026.

Table 6: Park Land Service Level Impacts from New Development Activity, 2017-2026

Year	Population	Service Levels If No New Facilities – Acres per 1,000 Persons	Cost Service Levels If No New Facilities – per Capita
2017	7,462	1.85	\$193.81
2018	7,679	1.79	\$188.33
2019	7,903	1.74	\$182.99
2020	8,133	1.69	\$177.82
2021	8,354	1.65	\$173.11
2022	8,581	1.61	\$168.53
2023	8,814	1.56	\$164.08
2024	9,054	1.52	\$159.73
2025	9,300	1.48	\$155.51
2026	9,537	1.45	\$151.64

Park Improvements. Park improvement levels will decline, due to new development activity, from the existing service level of \$180.16 per capita to \$140.96 per capita by 2026, if no new improvements are made.

Table 7: Park Improvement Service Level Impacts from New Development Activity, 2017-2026

Year	Population	Population Growth	Cost Service Levels If No New Facilities – per Capita
2017	7,462	-	\$180.16
2018	7,679	217	\$175.07

Year	Population	Population Growth	Cost Service Levels If No New Facilities – per Capita
2019	7,903	224	\$170.10
2020	8,133	230	\$165.29
2021	8,354	221	\$160.92
2022	8,581	227	\$156.66
2023	8,814	233	\$152.52
2024	9,054	240	\$148.48
2025	9,300	246	\$144.55
2026	9,537	237	\$140.96

Park Mowed Acres. The existing level of service of \$158.36 per capita will decline to \$123.91 per capita, if no new improvements are made.

Table 8: Park Mowed Acre Service Level Impacts from New Development Activity, 2017-2026

Year	Population	Service Levels If No New Facilities – Mowed Acres per 1,000 Persons	Cost Service Levels If No New Facilities – per Capita
2017	7,462	2.26	\$158.36
2018	7,679	2.19	\$153.89
2019	7,903	2.13	\$149.53
2020	8,133	2.07	\$145.30
2021	8,354	2.02	\$141.46
2022	8,581	1.96	\$137.71
2023	8,814	1.91	\$134.07
2024	9,054	1.86	\$130.52
2025	9,300	1.81	\$127.07
2026	9,537	1.77	\$123.91

Parking Areas. The existing level of service of \$24.38 per capita will decline to \$19.07 per capita, if no new improvements are made.

Table 9: Parking Asphalt Service Level Impacts from New Development Activity, 2017-2026

Year	Population	Service Levels If No New Facilities – Asphalt Acres per 1,000 Population	Cost Service Levels If No New Facilities – per Capita
2017	7,462	0.19	\$24.38
2018	7,679	0.19	\$23.69
2019	7,903	0.18	\$23.02
2020	8,133	0.18	\$22.37
2021	8,354	0.17	\$21.77

Year	Population	Service Levels If No New Facilities – Asphalt Acres per 1,000 Population	Cost Service Levels If No New Facilities – per Capita
2022	8,581	0.17	\$21.20
2023	8,814	0.16	\$20.64
2024	9,054	0.16	\$20.09
2025	9,300	0.16	\$19.56
2026	9,537	0.15	\$19.07

Trails. The existing level of service of \$19.16 per capita will decline to \$14.99 per capita, if no new improvements are made.

Table 10: Trail Service Level Impacts from New Development Activity, 2017-2026

Year	Population	Service Levels If No New Facilities – Linear Trail Feet per 1,000 Persons	Cost Service Levels If No New Facilities – per Capita
2017	7,462	0.48	\$19.16
2018	7,679	0.47	\$18.62
2019	7,903	0.45	\$18.09
2020	8,133	0.44	\$17.58
2021	8,354	0.43	\$17.11
2022	8,581	0.42	\$16.66
2023	8,814	0.41	\$16.22
2024	9,054	0.39	\$15.79
2025	9,300	0.38	\$15.37
2026	9,537	0.37	\$14.99

Trailheads. The existing level of service of \$20.10 per capita will decline to \$15.73 per capita, if no new improvements are made.

Table 11: Trailhead Service Level Impacts from New Development Activity, 2017-2026

Year	Population	Service Levels If No New Facilities – Trailheads per 1,000 Persons	Cost Service Levels If No New Facilities – per Capita
2017	7,462	0.402	\$20.10
2018	7,679	0.391	\$19.53
2019	7,903	0.380	\$18.98
2020	8,133	0.369	\$18.44
2021	8,354	0.359	\$17.96
2022	8,581	0.350	\$17.48

Year	Population	Service Levels If No New Facilities – Trail-heads per 1,000 Persons	Cost Service Levels If No New Facilities – per Capita
2023	8,814	0.340	\$17.02
2024	9,054	0.331	\$16.57
2025	9,300	0.323	\$16.13
2026	9,537	0.315	\$15.73

2 Impact on System Improvements by Anticipated Development Activity

Utah Code 11-36a-304(1)(b): an impact fee analysis shall identify the anticipated impact on system improvements required by the anticipated development activity to maintain the established level of service for each public facility;

Parks

The City will need to acquire additional park land, park improvements, mowed acres and parking spaces in order to maintain its existing service levels. Service levels will decline, as a result of population growth unless new facilities are constructed or acquired.

The City will need to make an investment of \$402,152 in park land by 2026 in order to maintain its existing service levels.

TABLE 12: PARK LAND IMPACTS FROM NEW DEVELOPMENT ACTIVITY

Year	Population	Population Growth	Additional Investment Needed to Maintain Existing Levels
2017	7,462		
2018	7,679	217	\$42,056
2019	7,903	224	\$43,413
2020	8,133	230	\$44,576
2021	8,354	221	\$42,832
2022	8,581	227	\$43,994
2023	8,814	233	\$45,157
2024	9,054	240	\$46,514
2025	9,300	246	\$47,677
2026	9,537	237	\$45,933
TOTAL		2,075	\$402,152

The City will need to make an additional \$373,826 investment in park improvements by 2026 in order to maintain its existing service levels.

TABLE 13: PARK IMPROVEMENT IMPACTS FROM NEW DEVELOPMENT ACTIVITY

Year	Population	Population Growth	Additional Investment Needed
2017	7,462		
2018	7,679	217	\$39,094
2019	7,903	224	\$40,355
2020	8,133	230	\$41,436
2021	8,354	221	\$39,815
2022	8,581	227	\$40,896
2023	8,814	233	\$41,977
2024	9,054	240	\$43,238
2025	9,300	246	\$44,319
2026	9,537	237	\$42,697
TOTAL		2,075	\$373,826

The City will need to make an additional \$328,607 of investment in mowed acres by 2026 in order to maintain the existing service levels.

TABLE 14: PARK MOWED ACRE IMPACTS FROM NEW DEVELOPMENT ACTIVITY

Year	Population	Population Growth	Additional Investment Needed
2017	7,462		
2018	7,679	217	\$34,365
2019	7,903	224	\$35,474
2020	8,133	230	\$36,424
2021	8,354	221	\$34,999
2022	8,581	227	\$35,949
2023	8,814	233	\$36,899
2024	9,054	240	\$38,008
2025	9,300	246	\$38,958
2026	9,537	237	\$37,532
TOTAL		2,075	\$328,607

The City will need to make an additional \$50,584 of improvements to parking by 2026 in order to maintain the existing service levels for paved parking.

TABLE 15: PARKING IMPACTS FROM NEW DEVELOPMENT ACTIVITY

Year	Population	Population Growth	Additional Investment Needed
2017	7,462		
2018	7,679	217	\$5,290
2019	7,903	224	\$5,461
2020	8,133	230	\$5,607

Year	Population	Population Growth	Additional Investment Needed
2021	8,354	221	\$5,387
2022	8,581	227	\$5,534
2023	8,814	233	\$5,680
2024	9,054	240	\$5,851
2025	9,300	246	\$5,997
2026	9,537	237	\$5,778
TOTAL		2,075	\$50,584

Trails

The City will need to make an additional \$39,754 of improvements to trails by 2026 in order to maintain the existing service level for trails.

TABLE 16: TRAIL MILE IMPACTS FROM NEW DEVELOPMENT ACTIVITY

Year	Population	Population Growth	Additional Investment Needed
2017	7,462		
2018	7,679	217	\$4,157
2019	7,903	224	\$4,291
2020	8,133	230	\$4,406
2021	8,354	221	\$4,234
2022	8,581	227	\$4,349
2023	8,814	233	\$4,464
2024	9,054	240	\$4,598
2025	9,300	246	\$4,713
2026	9,537	237	\$4,541
TOTAL		2,075	\$39,754

The City will need to make an additional \$41,711 of improvements to trailheads by 2026 in order to maintain the existing service level for trailheads.

TABLE 17: TRAILHEAD IMPACTS FROM NEW DEVELOPMENT ACTIVITY

Year	Population	Population Growth	Additional Investment Needed
2017	7,462		
2018	7,679	217	\$4,362
2019	7,903	224	\$4,503
2020	8,133	230	\$4,623
2021	8,354	221	\$4,443
2022	8,581	227	\$4,563
2023	8,814	233	\$4,684
2024	9,054	240	\$4,824
2025	9,300	246	\$4,945
2026	9,537	237	\$4,764
TOTAL		2,075	\$41,711

Relationship of Anticipated Impacts to Anticipated Development Activity

3

Utah Code 11-36a-304(1)(c): an impact fee analysis shall subject to Subsection (2), demonstrate how the anticipated impacts described in Subsections (1)(a) and (b) are reasonably related to the anticipated development activity;

The demand placed on existing park and trail facilities by new development activity is attributed to population growth. South Weber has a 2017 population of 7,462 persons and as a result of anticipated development activity will grow to a projected 9,537 persons by 2026 – an increase of 2,075 persons. As growth occurs as a result of increased development activity, more parks and trails are needed to maintain existing standards.

Proportionate Share Analysis

4

Utah Code 11-36a-304(1)(d)(i)(ii): an impact fee analysis shall estimate the proportionate share of costs for existing capacity that will be recouped; and the costs of impacts on system improvements that are reasonably related to the new development activity;

Costs for Existing Excess Capacity

The City has no excess capacity in any of its parks or trails facilities.

Costs Reasonably Related to New Development Activity

The cost of new system improvements required to maintain the existing level of parks and trail services related to new development activity is based on the cost of system-wide park facilities, as well as consultant fees for the preparation of the Impact Fee Facilities Plan and the Impact Fee Analysis.

The per capita cost to maintain the existing level of service for system-wide park land is \$193.81.

TABLE 18: PER CAPITA COST TO MAINTAIN LOS FOR PARK LAND

Description	Amount
Cost to Maintain Existing Park Land LOS (2017 – 2026)	\$402,151.95
Projected Population Growth (2017 - 2026)	2,075
Cost per Capita – Park Land	\$193.81

The per capita cost to maintain the existing level of service for system-wide park improvements³ is \$180.16.

TABLE 19: PER CAPITA COST TO MAINTAIN LOS FOR PARK IMPROVEMENTS

Description	Amount
Cost to Maintain Existing Park Improvements LOS (2017 – 2026)	\$373,826.06
Projected Population Growth (2017 - 2026)	2,075
Cost per Capita - Park Improvements	\$180.16

³ Includes restrooms, pavilions, playground equipment, sport courts and fields, etc.

The per capita cost to maintain the level of service for mowed acres is \$158.36.

TABLE 20: PER CAPITA COST TO MAINTAIN LOS FOR MOWED ACRES

Description	Amount
Cost to Maintain Existing Park Mowed Acres LOS (2017 – 2026)	\$328,606.77
Projected Population Growth (2017 - 2026)	2,075
Cost per Capita – Mowed Acres	\$158.36

The per capita cost to maintain the proposed level of service for parking is \$24.38.

TABLE 21: PER CAPITA COST TO MAINTAIN LOS FOR PARKING

Description	Amount
Cost to Maintain Existing Parking LOS (2017 - 2026)	\$50,583.77
Projected Population Growth (2017 - 2026)	2,075
Cost per Capita – Parking	\$24.38

The per capita cost to maintain the existing level of service for trails is \$19.16.

TABLE 22: PER CAPITA COST TO MAINTAIN LOS FOR TRAILS

Description	Amount
Cost to Maintain Existing Trails LOS (2017 - 2026)	\$39,753.69
Projected Population Growth (2017 - 2026)	2,075
Cost per Capita – Trails	\$19.16

The per capita cost to maintain the existing level of service for trailheads \$20.10.

TABLE 23: PER CAPITA COST TO MAINTAIN LOS FOR TRAILHEADS

Description	Amount
Cost to Maintain Existing Trailheads LOS (2017 - 2026)	\$41,711.34
Projected Population Growth (2017 - 2026)	2,075
Cost per Capita – Trailheads	\$20.10

The Impact Fee Facilities Plan and Impact Fee Analysis consultant cost is \$3.90 per capita.

TABLE 24: PER CAPITA CONSULTANT COSTS

Description	Amount
Consultant Cost	\$8,100
Projected Population Growth (2017 - 2026)	2,075
Cost per Capita – Consultant Costs	\$3.90

5 Impact Fee Credits

Utah Code 11-36a-304(1)(e): an impact fee analysis shall, based on the requirements of this chapter, identify how the impact fee was calculated;

The total gross Parks, Recreation, Trails and Open Space Impact Fee is \$582.39 per capita.

TABLE 25: MAXIMUM ALLOWABLE IMPACT FEE

Summary	Amount
Land	\$193.81
Park Improvements	\$180.16
Mowed Acres	\$158.36
Parking Areas	\$24.38
Trails	\$19.16
Trail Structures	\$20.10
Consultant Costs	\$3.90
Credit for Impact Fee Fund Balance	(\$17.48)
TOTAL	\$582.39

The City may choose to either charge one fee for every type of residential unit, or it can charge different fees for single-family and multi-family units. The average household size for a residential unit in South Weber is 3.54 persons⁴ when both single-family and multi-family units are combined. However, impact fees are usually charged based on single-family residential units and multi-family residential units. Therefore, maximum fees for single-family residential units are somewhat higher than the maximum fees for multi-family units due to their larger household sizes.

TABLE 26: CALCULATION OF GROSS IMPACT FEE PER RESIDENTIAL UNIT

Single-Family Residential	3.6	\$2,096.62
Multi-Family Residential	3.54	\$1,787.95
Non-Residential Development		No Fee

Source: United States Census 2010

The maximum impact fee that can be charged is therefore \$2,096.62 per single-family residential unit and \$1,787.95 per multi-family unit. No impact fees for parks, trails and recreation are charged to non-residential development.

⁴ Source: United States Census 2010.

6

Manner of Financing

Utah Code 11-36a-304(2)(c)(d)(e)(f)(g)(h): an impact fee analysis shall identify, if applicable: other than impact fees, the manner of financing for each public facility such as user charges, special assessments, bonded indebtedness, federal taxes, or federal grants;

An impact fee is a one-time fee that is implemented by a local government on new development to help fund and pay for all or a portion of the costs of public facilities that are needed to serve new development. These fees are usually implemented to help reduce the economic burden on local jurisdictions that are trying to deal with population and commercial growth within the area. As a matter of policy and legislative discretion, a City may choose to have new development pay the full cost of its share of new public facilities if the facilities would not be needed except to service new development. However, local governments may use other sources of revenue to pay for the new facilities required to service new development and use impact fees to recover the cost difference between the total cost and the other sources of revenue. Additionally, impact fees allow new growth to share in the cost of existing facilities that have excess capacity.

At the current time, no other sources of funding other than impact fees have been identified, but to the extent that any are identified and received in the future, then impact fees will be reduced accordingly.

Impact Fee Credits

The Impact Fees Act requires credits to be paid back to development for future fees that may be paid to fund system improvements found in the IFFP so that new development is not charged twice. Credits may also be paid back to developers who have constructed or directly funded items that are included in the IFFP or donated to the City in lieu of impact fees, including the dedication of land for system improvements. This situation does not apply to developer exactions or improvements required to offset density or as a condition for development. Any item for which a developer receives credit should be included in the IFFP and must be agreed upon with the City before construction begins.

In the situation that a developer chooses to construct facilities found in the IFFP in lieu of impact fees, the arrangement must be made through the developer and the City.

The standard impact fee can also be decreased to respond to unusual circumstances in specific cases in order to ensure that impact fees are imposed fairly. In certain cases, a developer may submit studies and data that clearly show a need for adjustment.

At the discretion of the City, impact fees may be modified for low-income housing, although alternate sources of funding for the recreation facilities must be identified.

Extraordinary Costs and Time Price Differential

It is not anticipated that there will be any extraordinary costs in servicing newly developed park properties. To account for the time-price differential inherent in fair comparisons of amounts paid at different times, actual costs have been used to compute buy-in costs to public facilities with excess capacity and current costs have been used to compute impacts on system improvements required by anticipated development activity to maintain the established level of service for each public facility.

Certification

Zions Public Finance, Inc. certifies that the attached impact fee analysis:

1. includes only the costs of public facilities that are:
 - a. allowed under the Impact Fees Act; and
 - b. actually incurred; or
 - c. projected to be incurred or encumbered within six years after the day on which each impact fee is paid;

2. does not include:
 - a. costs of operation and maintenance of public facilities;
 - b. costs for qualifying public facilities that will raise the level of service for the facilities, through impact fees, above the level of service that is supported by existing residents;
 - c. an expense for overhead, unless the expense is calculated pursuant to a methodology that is consistent with generally accepted cost accounting practices and the methodological standards set forth by the federal Office of Management and Budget for federal grant reimbursement;

3. offsets costs with grants or other alternate sources of payment; and

4. complies in each and every relevant respect with the Impact Fees Act.

Appendix A – Notice of Intent to Prepare an Impact Fee Analysis

Utah Code 11-36a-503: Before preparing or contracting to prepare an impact fee analysis, each local political subdivision... shall post a public notice on the Utah Public Notice Website created under section 63F-1-701.

Documents Updated

- [IFFP Intent.pdf - 1/30/17 2:21 PM](#)

City Council

[Notice of intent to prepare an impact facilities plan](#)

Notice Date & Time: 2/7/17 5:00 PM

Description/Agenda:

Pursuant to the requirements of Utah Code Ann. 11-36a-501 and 11-36a-503, notice is hereby given of South Weber City's to contract to prepare or amend Impact Fee Facilities Plans and Impact Fee Written Analysis for culinary water, sewer, storm water, streets, parks and trails, fire, and public safety. The geographical area where the proposed impact fee facilities will be located is the entire City limits.

Notice of Special Accommodations:

N/A

Notice of Electronic or telephone participation:

N/A

Other information:

Location:

1600 E. South Weber Dr., South Weber, 84405

Contact information:

Tom Smith, tsmith@southwebercity.com, 8014793177



PO Box 147
 Hooper, UT 84315
 Phone-801-731-3239
 Fax-801-731-0785

Estimate: 2881

service@kirkmobilerepair.com

Date: 8/10/2017

Customer:

South Weber City
 Bryan Wageman
 1600 E. South Weber Dr.
 South Weber, UT 84405
 Unit: Dumptruck

Unit Info:

Description	Qty	Rate	Total
This estimate is to replace bad left cylinder			
Labor	12	100.00	1,200.00T
Hydraulic multistage bed lift	1	4,434.77	4,434.77T
AW 46 Hydraulic Oil Bulk Gallon	10	18.56	185.60T
Misc. Shop Supplies	1	30.00	30.00T
<p>This estimate is valid for 30 days. Core charges and freight charges may apply. <i>Thank you for choosing Kirk Mobile Repair!</i></p>			<p>Subtotal \$5,850.37</p> <p>Sales Tax (0.0%) \$0.00</p> <p>Total \$5,850.37</p>

South Weber City

Mark Larsen 1-801-458-4835

Job 31334

Model. Tenco
S/N 23673

October 20, 2017

QTY	Part	Description	Dir Net List Ea.	List Price	Vendor	Availability	Vendor
1	649 28 0084	Cylinder	\$2,725.37	\$2,725.37		10 days	Tencousa
1	Freight In	Shipping & Handling Approx.	\$292.80	\$292.80			
	Labor	Plus Labor hours ?????		\$0.00			
				\$0.00			
				\$0.00			
				\$0.00			
				\$0.00			
Totals			\$0.00	\$3,018.17			