

SOUTH WEBER CITY COUNCIL AGENDA

PUBLIC NOTICE is hereby given that the City Council of SOUTH WEBER CITY, Utah, will meet in a regular public meeting on Tuesday, November 26, 2019 in the Council Chambers, 1600 E. South Weber Dr., commencing at 6:00 p.m.

COUNCIL MEETING (Agenda items may be moved in order or sequence to meet the needs of the Council.)

1. **Pledge of Allegiance:** Councilman Hyer
2. **Prayer:** Councilman Winsor
3. **Public Comment:** Please respectfully follow these guidelines
 - a. Individuals may speak once for 3 minutes or less
 - b. State your name and address for the record
 - c. Speak to the entire City Council
 - d. Do not comment from the audience
 - e. Note City Council will not respond during the public comment period
4. **Consent Agenda**
 - a. September Budget to Actual
 - b. September Check register
 - c. October Check Register
5. **Westside Reservoir Rehabilitation Project**—Change Order #1
6. **Ordinance 19-16:** Amending the Residential High-Density (R-H) Zoning District to Residential Multi-Family (R-7)
7. **Ordinance 19-17:** Amending City Code 10-7-2 Regarding Conditional Use Permit Requirements
8. **Consider Revocation:** Conditional Use Permit #STR 19-03 at 1923 E Canyon Drive
9. **Discussion:** Plume maps by Brent Poll
10. **New Business**
11. **Reports:**
 - a. Mayor
 - b. Council Members
 - c. City Manager
12. **Adjourn**

In compliance with the Americans With Disabilities Act, individuals needing special accommodations during this meeting should notify the City Recorder, 1600 East South Weber Drive, South Weber, Utah 84405 (801-479-3177) at least two days prior to the meeting.

THE UNDERSIGNED DULY APPOINTED CITY RECORDER FOR THE MUNICIPALITY OF SOUTH WEBER CITY HEREBY CERTIFIES THAT A COPY OF THE FOREGOING NOTICE WAS MAILED, EMAILED, OR POSTED TO: 1. CITY OFFICE BUILDING 2. FAMILY ACTIVITY CENTER 3. CITY WEBSITE www.southwebercity.com 4. UTAH PUBLIC NOTICE WEBSITE www.pmn.utah.gov 5. THE GOVERNING BODY MEMBERS 6. OTHERS ON THE AGENDA

DATE:

CITY RECORDER: Lisa Smith

SOUTH WEBER CITY CORPORATION
REVENUES WITH COMPARISON TO BUDGET
FOR THE 3 MONTHS ENDING SEPTEMBER 30, 2019

GENERAL FUND

	PERIOD ACTUAL	YTD ACTUAL	BUDGET	UNEARNED	PCNT
<u>TAXES</u>					
10-31-100	17.81	17.81	701,000.00	700,982.19	.0
10-31-120	61.68	61.68	20,000.00	19,938.32	.3
10-31-200	2,517.46	2,517.46	25,000.00	22,482.54	10.1
10-31-300	.00	.00	701,000.00	701,000.00	.0
10-31-305	.00	.00	.00	.00	.0
10-31-310	24,312.85	77,237.29	400,000.00	322,762.71	19.3
TOTAL TAXES	26,909.80	79,834.24	1,847,000.00	1,767,165.76	4.3
<u>LICENSES AND PERMITS</u>					
10-32-100	.00	490.00	8,000.00	7,510.00	6.1
10-32-210	13,006.86	73,383.25	310,000.00	236,616.75	23.7
10-32-290	6,250.02	24,279.83	.00	(24,279.83)	.0
10-32-310	.00	.00	.00	.00	.0
TOTAL LICENSES AND PERMITS	19,256.88	98,153.08	318,000.00	219,846.92	30.9
<u>INTERGOVERNMENTAL REVENUE</u>					
10-33-400	.00	1,500.00	.00	(1,500.00)	.0
10-33-550	.00	.00	.00	.00	.0
10-33-560	35,246.89	35,246.89	94,000.00	58,753.11	37.5
10-33-580	.00	.00	5,000.00	5,000.00	.0
TOTAL INTERGOVERNMENTAL REVENUE	35,246.89	36,746.89	99,000.00	62,253.11	37.1
<u>CHARGES FOR SERVICES</u>					
10-34-100	1,150.00	2,150.00	15,000.00	12,850.00	14.3
10-34-105	.00	.00	80,000.00	80,000.00	.0
10-34-250	90.00	807.00	.00	(807.00)	.0
10-34-254	.00	.00	.00	.00	.0
10-34-270	.00	.00	.00	.00	.0
10-34-560	7,582.10	17,343.16	100,000.00	82,656.84	17.3
10-34-760	.00	.00	.00	.00	.0
TOTAL CHARGES FOR SERVICES	8,822.10	20,300.16	195,000.00	174,699.84	10.4
<u>FINES AND FORFEITURES</u>					
10-35-100	4,844.18	20,083.99	85,000.00	64,916.01	23.6
TOTAL FINES AND FORFEITURES	4,844.18	20,083.99	85,000.00	64,916.01	23.6

SOUTH WEBER CITY CORPORATION
REVENUES WITH COMPARISON TO BUDGET
FOR THE 3 MONTHS ENDING SEPTEMBER 30, 2019

GENERAL FUND

	PERIOD ACTUAL	YTD ACTUAL	BUDGET	UNEARNED	PCNT
<u>MISCELLANEOUS REVENUE</u>					
10-36-100 INTEREST EARNINGS	19,378.89	85,388.99	17,000.00	(68,388.99)	502.3
10-36-300 NEWSLETTER SPONSORS	.00	.00	.00	.00	.0
10-36-400 SALE OF ASSETS	.00	.00	.00	.00	.0
10-36-900 SUNDRY REVENUES	231.75	1,154.26	5,500.00	4,345.74	21.0
10-36-901 FARMERS MARKET	.00	.00	.00	.00	.0
TOTAL MISCELLANEOUS REVENUE	19,610.64	86,543.25	22,500.00	(64,043.25)	384.6
<u>CONTRIBUTIONS AND TRANSFERS</u>					
10-39-091 TRANSFER FROM CAPITAL PROJECTS	.00	.00	.00	.00	.0
10-39-100 FIRE AGREEMENT/JOB CORPS	.00	.00	3,500.00	3,500.00	.0
10-39-110 FIRE AGREEMENT/COUNTY	.00	.00	1,000.00	1,000.00	.0
10-39-300 TRANSFER FOR ADMINI. SERVICES	.00	.00	167,000.00	167,000.00	.0
10-39-800 TFR FROM IMPACT FEES	.00	.00	40,000.00	40,000.00	.0
10-39-900 FUND BALANCE TO BE APPROPRIATE	.00	.00	.00	.00	.0
10-39-910 TRANSFER FROM CLASS "C" RES.	.00	.00	.00	.00	.0
TOTAL CONTRIBUTIONS AND TRANSFERS	.00	.00	211,500.00	211,500.00	.0
TOTAL FUND REVENUE	114,690.49	341,661.61	2,778,000.00	2,436,338.39	12.3

SOUTH WEBER CITY CORPORATION
 EXPENDITURES WITH COMPARISON TO BUDGET
 FOR THE 3 MONTHS ENDING SEPTEMBER 30, 2019

GENERAL FUND

	PERIOD ACTUAL	YTD ACTUAL	BUDGET	UNEXPENDED	PCNT
<u>LEGISLATIVE</u>					
10-41-005 SALARIES - COUNCIL & COMMISSIO	2,000.00	4,000.00	28,000.00	24,000.00	14.3
10-41-131 EMPLOYEE BENEFIT-EMPLOYER FICA	153.00	306.00	2,200.00	1,894.00	13.9
10-41-133 EMPLOYEE BENEFIT - WORK. COMP.	47.20	94.40	700.00	605.60	13.5
10-41-140 UNIFORMS	.00	.00	300.00	300.00	.0
10-41-210 BOOKS/SUBSCRIPTIONS/MEMBERSHIP	.00	3,848.17	4,000.00	151.83	96.2
10-41-230 TRAVEL & TRAINING	304.47	304.47	12,600.00	12,295.53	2.4
10-41-240 OFFICE SUPPLIES AND EXPENSE	.00	.00	200.00	200.00	.0
10-41-370 PROFESSIONAL/TECHNICAL SERVICE	.00	.00	.00	.00	.0
10-41-494 YOUTH CITY COUNCIL	.00	435.00	3,000.00	2,565.00	14.5
10-41-620 MISCELLANEOUS	100.00	100.00	4,000.00	3,900.00	2.5
10-41-740 EQUIPMENT	.00	.00	.00	.00	.0
10-41-925 TRANSFER TO COUNTRY FAIR DAYS	.00	.00	5,000.00	5,000.00	.0
TOTAL LEGISLATIVE	2,604.67	9,088.04	60,000.00	50,911.96	15.2
<u>JUDICIAL</u>					
10-42-004 JUDGE SALARY	.00	.00	16,000.00	16,000.00	.0
10-42-110 EMPLOYEE SALARIES	3,567.61	8,341.18	34,000.00	25,658.82	24.5
10-42-130 EMPLOYEE BENEFIT - RETIREMENT	702.84	1,643.25	11,000.00	9,356.75	14.9
10-42-131 EMPLOYEE BENEFIT-EMPLOYER FICA	265.62	621.06	4,000.00	3,378.94	15.5
10-42-133 EMPLOYEE BENEFIT - WORK. COMP.	11.04	26.46	500.00	473.54	5.3
10-42-134 EMPLOYEE BENEFIT - UI	.00	.00	500.00	500.00	.0
10-42-135 EMPLOYEE BENEFIT - HEALTH INS.	1,423.23	3,320.87	14,000.00	10,679.13	23.7
10-42-210 BOOKS/SUBSCRIPTIONS/MEMBERSHIP	518.61	518.61	600.00	81.39	86.4
10-42-230 TRAVEL & TRAINING	.00	100.00	1,500.00	1,400.00	6.7
10-42-240 OFFICE SUPPLIES & EXPENSE	104.12	147.06	400.00	252.94	36.8
10-42-243 COURT REFUNDS	.00	.00	.00	.00	.0
10-42-280 TELEPHONE	60.00	140.00	.00	(140.00)	.0
10-42-313 PROFESSIONAL/TECH. - ATTORNEY	918.75	3,493.75	10,000.00	6,506.25	34.9
10-42-317 PROFESSIONAL/TECHNICAL-BAILIFF	.00	791.50	4,000.00	3,208.50	19.8
10-42-350 SOFTWARE MAINTENANCE	59.70	119.40	800.00	680.60	14.9
10-42-550 BANKING CHARGES	20.13	34.69	1,200.00	1,165.31	2.9
10-42-610 MISCELLANEOUS	.00	153.60	1,500.00	1,346.40	10.2
10-42-740 EQUIPMENT	1,725.05	1,725.05	.00	(1,725.05)	.0
TOTAL JUDICIAL	9,376.70	21,176.48	100,000.00	78,823.52	21.2

SOUTH WEBER CITY CORPORATION
EXPENDITURES WITH COMPARISON TO BUDGET
FOR THE 3 MONTHS ENDING SEPTEMBER 30, 2019

GENERAL FUND

	PERIOD ACTUAL	YTD ACTUAL	BUDGET	UNEXPENDED	PCNT
<u>ADMINISTRATIVE</u>					
10-43-110 FULL-TIME EMPLOYEE SALARIES	34,446.82	80,041.31	331,000.00	250,958.69	24.2
10-43-120 PART-TIME EMPLOYEE SALARIES	407.26	4,540.53	33,000.00	28,459.47	13.8
10-43-125 EMPLOYEE INCENTIVE	.00	.00	.00	.00	.0
10-43-130 EMPLOYEE BENEFIT - RETIREMENT	6,634.96	15,669.80	78,000.00	62,330.20	20.1
10-43-131 EMPLOYEE BENEFIT-EMPLOYER FICA	10,160.04	13,896.67	28,000.00	14,103.33	49.6
10-43-133 EMPLOYEE BENEFIT - WORK. COMP.	298.00	713.32	3,200.00	2,486.68	22.3
10-43-134 EMPLOYEE BENEFIT - UI	.00	.00	4,800.00	4,800.00	.0
10-43-135 EMPLOYEE BENEFIT - HEALTH INS.	8,706.88	21,621.73	97,000.00	75,378.27	22.3
10-43-136 HRA REIMBURSEMENT - HEALTH INS	75.00	75.00	6,000.00	5,925.00	1.3
10-43-137 EMPLOYEE TESTING	.00	.00	.00	.00	.0
10-43-140 UNIFORMS	63.71	63.71	1,000.00	936.29	6.4
10-43-210 BOOKS/SUBSCRIPTIONS/MEMBERSHIP	.00	440.00	3,500.00	3,060.00	12.6
10-43-220 PUBLIC NOTICES	.00	1,466.00	5,000.00	3,534.00	29.3
10-43-230 TRAVEL & TRAINING	82.20	220.41	20,000.00	19,779.59	1.1
10-43-240 OFFICE SUPPLIES & EXPENSE	573.14	2,021.92	8,000.00	5,978.08	25.3
10-43-250 EQUIPMENT - SUPPLIES AND MAINT	1,000.71	1,336.73	4,000.00	2,663.27	33.4
10-43-252 EQUIPMENT MAINT. - CASELLE	.00	.00	.00	.00	.0
10-43-253 EQUIPMENT MAINT. - SOFTWARE	.00	.00	.00	.00	.0
10-43-256 FUEL EXPENSE	.00	.00	.00	.00	.0
10-43-262 GENERAL GOVERNMENT BUILDINGS	504.45	1,143.58	7,500.00	6,356.42	15.3
10-43-270 UTILITIES	537.17	847.55	4,500.00	3,652.45	18.8
10-43-280 TELEPHONE	1,535.17	4,566.22	18,000.00	13,433.78	25.4
10-43-308 PROFESSIONAL & TECH - I.T.	1,542.86	3,207.00	14,000.00	10,793.00	22.9
10-43-309 PROFESSIONAL & TECH - AUDITOR	.00	.00	10,000.00	10,000.00	.0
10-43-310 PROFESSIONAL/TECH. - PLANNER	.00	.00	.00	.00	.0
10-43-311 PRO & TECH - ECO DEVELOPMENT	.00	.00	.00	.00	.0
10-43-312 PROFESSIONAL & TECH. - ENGINR	.00	89.25	.00	(89.25)	.0
10-43-313 PROFESSIONAL/TECH. - ATTORNEY	637.50	3,150.00	25,000.00	21,850.00	12.6
10-43-314 ORDINANCE CODIFICATION	.00	2,178.00	3,000.00	822.00	72.6
10-43-316 ELECTIONS	.00	.00	16,000.00	16,000.00	.0
10-43-319 PROF./TECH. -SUBD. REVIEWS	.00	.00	.00	.00	.0
10-43-329 CITY MANAGER FUND	277.71	277.71	3,000.00	2,722.29	9.3
10-43-350 SOFTWARE MAINTENANCE	1,190.07	5,329.05	24,000.00	18,670.95	22.2
10-43-360 EDUCATION & TRAINING	.00	.00	.00	.00	.0
10-43-510 INSURANCE & SURETY BONDS	.00	40,993.12	45,000.00	4,006.88	91.1
10-43-550 BANKING CHARGES	20.13	34.69	3,000.00	2,965.31	1.2
10-43-610 MISCELLANEOUS	.00	.00	5,000.00	5,000.00	.0
10-43-620 MISCELLANEOUS	.00	.00	.00	.00	.0
10-43-621 CONTRIBUTIONS & DONATIONS	.00	.00	.00	.00	.0
10-43-625 CASH OVER AND SHORT	.00	(40.08)	.00	40.08	.0
10-43-720 BUILDINGS	.00	.00	.00	.00	.0
10-43-740 EQUIPMENT	1,842.00	(3,658.00)	27,000.00	30,658.00	(13.6)
10-43-745 EQUIPMENT COSTING OVER \$500	.00	.00	.00	.00	.0
10-43-841 TRANSFER TO RECREATION FUND	.00	.00	97,500.00	97,500.00	.0
10-43-910 TRANSFER TO CAP. PROJ. FUND	.00	.00	.00	.00	.0
TOTAL ADMINISTRATIVE	70,535.78	200,225.22	925,000.00	724,774.78	21.7

SOUTH WEBER CITY CORPORATION
EXPENDITURES WITH COMPARISON TO BUDGET
FOR THE 3 MONTHS ENDING SEPTEMBER 30, 2019

GENERAL FUND

	PERIOD ACTUAL	YTD ACTUAL	BUDGET	UNEXPENDED	PCNT
<u>PUBLIC SAFETY</u>					
10-54-310 SHERIFF'S DEPARTMENT	36,980.00	55,470.00	230,000.00	174,530.00	24.1
10-54-311 ANIMAL CONTROL	3,230.16	4,845.24	21,000.00	16,154.76	23.1
10-54-320 EMERGENCY PREPAREDNESS	.00	.00	2,000.00	2,000.00	.0
10-54-321 LIQUOR LAW ENFORCEMENT	.00	.00	5,000.00	5,000.00	.0
TOTAL PUBLIC SAFETY	40,210.16	60,315.24	258,000.00	197,684.76	23.4
<u>FIRE PROTECTION</u>					
10-57-110 FULL-TIME EMPLOYEE SALARIES	.00	.00	.00	.00	.0
10-57-120 PART-TIME EMPLOYEE SALARIES	46,422.51	104,355.58	370,000.00	265,644.42	28.2
10-57-131 EMPLOYEE BENEFIT-EMPLOYER FICA	3,557.10	7,996.59	29,000.00	21,003.41	27.6
10-57-133 EMPLOYEE BENEFIT - WORK. COMP.	1,574.81	3,650.42	14,000.00	10,349.58	26.1
10-57-134 EMPLOYEE BENEFIT - UI	.00	.00	5,000.00	5,000.00	.0
10-57-137 EMPLOYEE TESTING	17.95	185.80	500.00	314.20	37.2
10-57-140 UNIFORMS	.00	582.00	12,000.00	11,418.00	4.9
10-57-210 BOOKS/SUBSCRIPTIONS/MEMBERSHIP	.00	.00	2,500.00	2,500.00	.0
10-57-230 TRAVEL & TRAINING	1,416.00	1,416.00	12,000.00	10,584.00	11.8
10-57-240 OFFICE SUPPLIES & EXPENSE	8.56	550.98	1,000.00	449.02	55.1
10-57-250 EQUIPMENT SUPPLIES & MAINT.	37.98	226.69	40,000.00	39,773.31	.6
10-57-256 FUEL EXPENSE	441.81	737.46	4,000.00	3,262.54	18.4
10-57-260 BUILDINGS & GROUNDS MAINT.	.00	770.80	12,000.00	11,229.20	6.4
10-57-270 UTILITIES	483.21	826.13	5,000.00	4,173.87	16.5
10-57-280 TELEPHONE	266.50	1,141.63	5,000.00	3,858.37	22.8
10-57-350 SOFTWARE MAINTENANCE	59.70	119.40	6,000.00	5,880.60	2.0
10-57-370 PROFESSIONAL & TECH. SERVICES	652.58	2,358.66	13,000.00	10,641.34	18.1
10-57-375 PARAMEDIC SERVICES	.00	.00	.00	.00	.0
10-57-450 SPECIAL PUBLIC SAFETY SUPPLIES	4,011.11	5,469.87	25,000.00	19,530.13	21.9
10-57-530 INTEREST EXPENSE	.00	3,170.05	7,000.00	3,829.95	45.3
10-57-550 BANKING CHARGES	20.13	34.69	500.00	465.31	6.9
10-57-622 HEALTH & WELLNESS EXPENSES	.00	.00	1,500.00	1,500.00	.0
10-57-740 EQUIPMENT	.00	.00	.00	.00	.0
10-57-811 BOND PRINCIPAL	.00	.00	28,000.00	28,000.00	.0
TOTAL FIRE PROTECTION	58,969.95	133,592.75	593,000.00	459,407.25	22.5

SOUTH WEBER CITY CORPORATION
EXPENDITURES WITH COMPARISON TO BUDGET
FOR THE 3 MONTHS ENDING SEPTEMBER 30, 2019

GENERAL FUND

	PERIOD ACTUAL	YTD ACTUAL	BUDGET	UNEXPENDED	PCNT
<u>PLANNING & ENGINEERING</u>					
10-58-110 FULL-TIME EMPLOYEE SALARIES	9,763.80	23,687.27	82,000.00	58,312.73	28.9
10-58-120 PART-TIME EMPLOYEE SALARIES	5,805.60	12,147.67	33,000.00	20,852.33	36.8
10-58-130 EMPLOYEE BENEFIT - RETIREMENT	2,813.38	6,227.42	20,000.00	13,772.58	31.1
10-58-131 EMPLOYEE BENEFIT-EMPLOYER FICA	1,181.11	2,720.71	9,000.00	6,279.29	30.2
10-58-133 EMPLOYEE BENEFIT - WORK. COMP.	245.03	579.02	3,000.00	2,420.98	19.3
10-58-134 EMPLOYEE BENEFIT - UI	.00	.00	1,600.00	1,600.00	.0
10-58-135 EMPLOYEE BENEFIT - HEALTH INS.	1,184.37	2,666.93	10,000.00	7,333.07	26.7
10-58-137 EMPLOYEE TESTING	65.00	130.00	.00	(130.00)	.0
10-58-140 UNIFORMS	58.00	256.78	900.00	643.22	28.5
10-58-210 BOOKS/SUBSCRIPTIONS/MEMBERSHIP	27.85	27.85	1,500.00	1,472.15	1.9
10-58-230 TRAVEL & TRAINING	(52.20)	158.92	5,000.00	4,841.08	3.2
10-58-250 EQUIPMENT SUPPLIES & MAINT.	7,460.37	8,238.37	4,000.00	(4,238.37)	206.0
10-58-255 VEHICLE LEASE	.00	.00	.00	.00	.0
10-58-256 FUEL EXPENSE	.00	.00	1,000.00	1,000.00	.0
10-58-280 TELEPHONE	232.50	542.50	.00	(542.50)	.0
10-58-310 PROFESSIONAL & TCH. - PLANNER	1,715.00	7,070.00	12,000.00	4,930.00	58.9
10-58-311 PROFESSIONAL & TECH - ECODEV	.00	.00	.00	.00	.0
10-58-312 PROFESSIONAL & TECH. - ENGINR	4,552.25	28,474.50	60,000.00	31,525.50	47.5
10-58-319 PROF./TECH. -SUBD. REVIEWS	3,351.25	14,854.75	80,000.00	65,145.25	18.6
10-58-350 SOFTWARE MAINTENANCE	1,379.88	1,379.88	3,000.00	1,620.12	46.0
10-58-370 PROFESSIONAL & TECH. SERVICES	4.20	4.20	.00	(4.20)	.0
10-58-620 MISCELLANEOUS	.00	.00	2,000.00	2,000.00	.0
10-58-740 EQUIPMENT	.00	.00	.00	.00	.0
TOTAL PLANNING & ENGINEERING	39,787.39	109,166.77	328,000.00	218,833.23	33.3

SOUTH WEBER CITY CORPORATION
 EXPENDITURES WITH COMPARISON TO BUDGET
 FOR THE 3 MONTHS ENDING SEPTEMBER 30, 2019

GENERAL FUND

	PERIOD ACTUAL	YTD ACTUAL	BUDGET	UNEXPENDED	PCNT
<u>STREETS</u>					
10-60-110 FULL-TIME EMPLOYEE SALARIES	4,839.13	11,544.76	39,000.00	27,455.24	29.6
10-60-120 PART-TIME EMPLOYEE SALARIES	2,018.41	2,018.41	21,000.00	18,981.59	9.6
10-60-130 EMPLOYEE BENEFIT - RETIREMENT	934.07	2,255.33	10,000.00	7,744.67	22.6
10-60-131 EMPLOYEE BENEFIT-EMPLOYER FICA	512.18	1,008.69	4,500.00	3,491.31	22.4
10-60-133 EMPLOYEE BENEFIT - WORK. COMP.	161.76	328.37	1,700.00	1,371.63	19.3
10-60-134 EMPLOYEE BENEFIT - UI	.00	.00	800.00	800.00	.0
10-60-135 EMPLOYEE BENEFIT - HEALTH INS.	984.36	2,296.84	10,000.00	7,703.16	23.0
10-60-137 EMPLOYEE TESTING	.00	167.85	.00	(167.85)	.0
10-60-140 UNIFORMS	58.00	256.84	1,000.00	743.16	25.7
10-60-230 TRAVEL & TRAINING	.00	.00	2,000.00	2,000.00	.0
10-60-250 EQUIPMENT SUPPLIES & MAINT.	432.63	2,773.73	17,000.00	14,226.27	16.3
10-60-255 VEHICLE LEASE	.00	.00	.00	.00	.0
10-60-256 FUEL EXPENSE	444.55	1,028.46	5,000.00	3,971.54	20.6
10-60-260 BUILDINGS & GROUNDS MAINT.	125.48	515.42	10,000.00	9,484.58	5.2
10-60-271 UTILITIES - STREET LIGHTS	3,200.23	6,075.53	50,000.00	43,924.47	12.2
10-60-280 TELEPHONE	.00	.00	.00	.00	.0
10-60-312 PROFESSIONAL & TECH. - ENGINR	2,195.25	6,440.50	30,000.00	23,559.50	21.5
10-60-350 SOFTWARE MAINTENANCE	59.70	119.40	3,000.00	2,880.60	4.0
10-60-370 PROFESSIONAL & TECH. SERVICES	.00	.00	1,000.00	1,000.00	.0
10-60-410 SPECIAL HIGHWAY SUPPLIES	280.00	4,874.76	15,000.00	10,125.24	32.5
10-60-411 SNOW REMOVAL SUPPLIES	.00	.00	35,000.00	35,000.00	.0
10-60-420 WEED CONTROL	.00	.00	2,500.00	2,500.00	.0
10-60-422 CROSSWALK/STREET PAINTING	.00	.00	5,000.00	5,000.00	.0
10-60-424 CURB & GUTTER RESTORATION	.00	.00	.00	.00	.0
10-60-550 BANKING CHARGES	20.13	34.69	500.00	465.31	6.9
TOTAL STREETS	16,265.88	41,739.58	264,000.00	222,260.42	15.8

SOUTH WEBER CITY CORPORATION
EXPENDITURES WITH COMPARISON TO BUDGET
FOR THE 3 MONTHS ENDING SEPTEMBER 30, 2019

GENERAL FUND

	PERIOD ACTUAL	YTD ACTUAL	BUDGET	UNEXPENDED	PCNT
<u>PARKS</u>					
10-70-110 FULL-TIME EMPLOYEE SALARIES	9,281.54	20,763.04	55,000.00	34,236.96	37.8
10-70-120 PART-TIME EMPLOYEE SALARIES	.00	.00	16,000.00	16,000.00	.0
10-70-130 EMPLOYEE BENEFIT - RETIREMENT	1,689.92	3,918.00	14,000.00	10,082.00	28.0
10-70-131 EMPLOYEE BENEFIT-EMPLOYER FICA	692.02	1,565.17	6,000.00	4,434.83	26.1
10-70-133 EMPLOYEE BENEFIT - WORK. COMP.	202.85	480.19	3,000.00	2,519.81	16.0
10-70-134 EMPLOYEE BENEFIT - UI	.00	.00	2,000.00	2,000.00	.0
10-70-135 EMPLOYEE BENEFIT - HEALTH INS.	2,700.03	4,059.35	33,000.00	28,940.65	12.3
10-70-137 EMPLOYEE TESTING	.00	.00	.00	.00	.0
10-70-140 UNIFORMS	115.92	513.42	1,600.00	1,086.58	32.1
10-70-230 TRAVEL & TRAINING	.00	.00	2,500.00	2,500.00	.0
10-70-250 EQUIPMENT SUPPLIES & MAINT.	2,052.22	3,795.81	9,000.00	5,204.19	42.2
10-70-255 VEHICLE LEASE	.00	.00	.00	.00	.0
10-70-256 FUEL EXPENSE	404.76	887.46	5,000.00	4,112.54	17.8
10-70-260 BUILDINGS & GROUNDS MAINT.	.00	.00	10,000.00	10,000.00	.0
10-70-261 GROUNDS SUPPLIES & MAINTENANCE	4,442.03	10,060.94	35,000.00	24,939.06	28.8
10-70-270 UTILITIES	455.56	810.85	8,000.00	7,189.15	10.1
10-70-280 TELEPHONE	66.00	154.00	.00	(154.00)	.0
10-70-312 PROFESSIONAL & TECH. - ENGINR	1,910.25	3,551.25	20,000.00	16,448.75	17.8
10-70-350 SOFTWARE MAINTENANCE	59.70	119.40	600.00	480.60	19.9
10-70-430 TREES	.00	.00	2,000.00	2,000.00	.0
10-70-435 SAFETY INCENTIVE PROGRAM	.00	.00	.00	.00	.0
10-70-550 BANKING CHARGES	20.13	34.69	300.00	265.31	11.6
10-70-626 UTA PARK AND RIDE	43.31	130.21	15,700.00	15,569.79	.8
10-70-730 IMPROVEMENTS OTHER THAN BLDGS	.00	.00	.00	.00	.0
10-70-740 EQUIPMENT	.00	.00	1,300.00	1,300.00	.0
TOTAL PARKS	24,136.24	50,843.78	240,000.00	189,156.22	21.2
TOTAL FUND EXPENDITURES	261,886.77	626,147.86	2,768,000.00	2,141,852.14	22.6
NET REVENUE OVER EXPENDITURES	(147,196.28)	(284,486.25)	10,000.00	294,486.25	(2844.

SOUTH WEBER CITY CORPORATION
REVENUES WITH COMPARISON TO BUDGET
FOR THE 3 MONTHS ENDING SEPTEMBER 30, 2019

RECREATION FUND

	PERIOD ACTUAL	YTD ACTUAL	BUDGET	UNEXPENDED	PCNT
<u>RECREATION REVENUE</u>					
20-34-720 RENTAL - ACTIVITY CENTER	1,115.00	1,762.00	10,000.00	8,238.00	17.6
20-34-751 MEMBERSHIP FEES	2,040.00	5,304.00	20,000.00	14,696.00	26.5
20-34-752 COMPETITION LEAGUE FEES	.00	.00	17,000.00	17,000.00	.0
20-34-753 MISC REVENUE	12.00	62.00	1,000.00	938.00	6.2
20-34-754 COMPETITION BASEBALL	.00	280.00	.00	(280.00)	.0
20-34-755 BASKETBALL	2,381.00	2,425.00	14,000.00	11,575.00	17.3
20-34-756 BASEBALL & SOFTBALL	.00	.00	7,500.00	7,500.00	.0
20-34-757 SOCCER	515.00	4,490.00	8,000.00	3,510.00	56.1
20-34-758 FLAG FOOTBALL	160.00	3,450.00	4,500.00	1,050.00	76.7
20-34-759 VOLLEYBALL	70.00	1,330.00	2,000.00	670.00	66.5
20-34-811 SALES TAX BOND PMT-RESTRICTED	.00	.00	.00	.00	.0
20-34-841 GRAVEL PIT FEES	.00	.00	55,000.00	55,000.00	.0
TOTAL RECREATION REVENUE	6,293.00	19,103.00	139,000.00	119,897.00	13.7
<u>SOURCE 36</u>					
20-36-895 RENTAL OF UNIFORMS AND EQUIP	.00	.00	1,500.00	1,500.00	.0
TOTAL SOURCE 36	.00	.00	1,500.00	1,500.00	.0
<u>SOURCE 37</u>					
20-37-100 INTEREST EARNINGS	.00	.00	3,000.00	3,000.00	.0
TOTAL SOURCE 37	.00	.00	3,000.00	3,000.00	.0
<u>CONTRIBUTIONS & TRANSFERS</u>					
20-39-091 TRANSFER FROM CAPITAL PROJECTS	.00	.00	.00	.00	.0
20-39-470 TRANSFER FROM OTHER FUNDS	.00	.00	97,500.00	97,500.00	.0
20-39-800 TRANSFER FROM IMPACT FEE FUND	.00	.00	66,000.00	66,000.00	.0
20-39-900 FUND BALANCE TO BE APPROPRIATE	.00	.00	4,000.00	4,000.00	.0
TOTAL CONTRIBUTIONS & TRANSFERS	.00	.00	167,500.00	167,500.00	.0
TOTAL FUND REVENUE	6,293.00	19,103.00	311,000.00	291,897.00	6.1

SOUTH WEBER CITY CORPORATION
EXPENDITURES WITH COMPARISON TO BUDGET
FOR THE 3 MONTHS ENDING SEPTEMBER 30, 2019

RECREATION FUND

	PERIOD ACTUAL	YTD ACTUAL	BUDGET	UNEXPENDED	PCNT
<u>RECREATION EXPENDITURES</u>					
20-71-110 FULL-TIME EMPLOYEE SALARIES	5,690.11	15,713.51	54,000.00	38,286.49	29.1
20-71-120 PART-TIME EMPLOYEE SALARIES	4,563.99	9,641.97	51,000.00	41,358.03	18.9
20-71-130 EMPLOYEE BENEFIT - RETIREMENT	1,109.13	2,699.03	11,000.00	8,300.97	24.5
20-71-131 EMPLOYEE BENEFIT-EMPLOYER FICA	772.00	1,910.63	8,000.00	6,089.37	23.9
20-71-133 EMPLOYEE BENEFIT - WORK. COMP.	195.49	504.86	2,000.00	1,495.14	25.2
20-71-134 EMPLOYEE BENEFIT - UI	.00	.00	2,000.00	2,000.00	.0
20-71-135 EMPLOYEE BENEFIT - HEALTH INS.	1,139.01	2,657.69	11,000.00	8,342.31	24.2
20-71-137 EMPLOYEE TESTING	17.95	185.80	200.00	14.20	92.9
20-71-210 BOOKS/SUBSCRIPTIONS/MEMBERSHIP	.00	.00	.00	.00	.0
20-71-230 TRAVEL & TRAINING	.00	.00	1,500.00	1,500.00	.0
20-71-240 OFFICE SUPPLIES AND EXPENSE	81.78	81.78	1,000.00	918.22	8.2
20-71-241 MATERIALS & SUPPLIES	130.83	295.32	2,000.00	1,704.68	14.8
20-71-250 EQUIPMENT SUPPLIES & MAINT.	.00	385.25	1,000.00	614.75	38.5
20-71-256 FUEL EXPENSE	76.74	116.42	200.00	83.58	58.2
20-71-262 GENERAL GOVERNMENT BUILDINGS	.00	231.25	4,000.00	3,768.75	5.8
20-71-270 UTILITIES	5,646.70	5,670.11	7,000.00	1,329.89	81.0
20-71-280 TELEPHONE	205.87	505.45	4,000.00	3,494.55	12.6
20-71-331 PROMOTIONS	.00	.00	1,500.00	1,500.00	.0
20-71-340 PROGRAM OFFICIALS	.00	.00	.00	.00	.0
20-71-350 SOFTWARE MAINTENANCE	59.70	119.40	700.00	580.60	17.1
20-71-370 PROFESSIONAL/TECHNICAL SERVICE	.00	.00	.00	.00	.0
20-71-480 BASKETBALL	.00	1,796.75	11,000.00	9,203.25	16.3
20-71-481 BASEBALL & SOFTBALL	.00	268.92	7,000.00	6,731.08	3.8
20-71-482 SOCCER	806.02	1,447.32	4,500.00	3,052.68	32.2
20-71-483 FLAG FOOTBALL	1,260.70	1,290.06	3,000.00	1,709.94	43.0
20-71-484 VOLLEYBALL	341.00	424.39	2,000.00	1,575.61	21.2
20-71-485 SUMMER FUN	.00	88.06	2,000.00	1,911.94	4.4
20-71-486 SR LUNCHEON	66.94	381.31	1,500.00	1,118.69	25.4
20-71-488 COMPETITION BASKETBALL	.00	.00	9,000.00	9,000.00	.0
20-71-489 COMPETITION BASEBALL	.00	.00	300.00	300.00	.0
20-71-491 FLY FISHING	.00	.00	1,000.00	1,000.00	.0
20-71-510 INSURANCE & SURETY BONDS	.00	.00	.00	.00	.0
20-71-530 INTEREST EXPENSE	.00	8,151.57	17,000.00	8,848.43	48.0
20-71-550 BANKING CHARGES	20.13	34.69	800.00	765.31	4.3
20-71-610 MISCELLANEOUS	135.64	135.64	800.00	664.36	17.0
20-71-625 CASH OVER AND SHORT	.00	.00	.00	.00	.0
20-71-740 EQUIPMENT	.00	.00	1,000.00	1,000.00	.0
20-71-811 BOND PRINCIPAL	.00	.00	72,000.00	72,000.00	.0
20-71-900 TRANSFER TO FUND BALANCE	.00	.00	.00	.00	.0
20-71-915 TRANSFER TO ADMIN. SERVICES	.00	.00	16,000.00	16,000.00	.0
TOTAL RECREATION EXPENDITURES	22,319.73	54,737.18	311,000.00	256,262.82	17.6
TOTAL FUND EXPENDITURES	22,319.73	54,737.18	311,000.00	256,262.82	17.6
NET REVENUE OVER EXPENDITURES	(16,026.73)	(35,634.18)	.00	35,634.18	.0

SOUTH WEBER CITY CORPORATION
 REVENUES WITH COMPARISON TO BUDGET
 FOR THE 3 MONTHS ENDING SEPTEMBER 30, 2019

SEWER IMPACT FEE FUND

	PERIOD ACTUAL	YTD ACTUAL	BUDGET	UNEXPENDED	PCNT
<u>REVENUE</u>					
21-37-100 INTEREST EARNINGS	.00	.00	.00	.00	.0
21-37-200 IMPACT FEES	8,799.00	58,660.00	150,000.00	91,340.00	39.1
TOTAL REVENUE	8,799.00	58,660.00	150,000.00	91,340.00	39.1
<u>CONTRIBUTIONS & TRANSFERS</u>					
21-39-900 FUND BAL TO BE APPROPRIATED	.00	.00	100,000.00	100,000.00	.0
TOTAL CONTRIBUTIONS & TRANSFERS	.00	.00	100,000.00	100,000.00	.0
TOTAL FUND REVENUE	8,799.00	58,660.00	250,000.00	191,340.00	23.5

SOUTH WEBER CITY CORPORATION
 EXPENDITURES WITH COMPARISON TO BUDGET
 FOR THE 3 MONTHS ENDING SEPTEMBER 30, 2019

SEWER IMPACT FEE FUND

	PERIOD ACTUAL	YTD ACTUAL	BUDGET	UNEXPENDED	PCNT
<u>EXPENDITURES</u>					
21-40-760 SEWER IMPACT FEE PROJECTS	.00	.00	.00	.00	.0
TOTAL EXPENDITURES	.00	.00	.00	.00	.0
<u>DEPARTMENT 80</u>					
21-80-800 TRANSFERS	.00	.00	250,000.00	250,000.00	.0
TOTAL DEPARTMENT 80	.00	.00	250,000.00	250,000.00	.0
TOTAL FUND EXPENDITURES	.00	.00	250,000.00	250,000.00	.0
NET REVENUE OVER EXPENDITURES	8,799.00	58,660.00	.00	(58,660.00)	.0

SOUTH WEBER CITY CORPORATION
 REVENUES WITH COMPARISON TO BUDGET
 FOR THE 3 MONTHS ENDING SEPTEMBER 30, 2019

STORM SEWER IMPACT FEE FUND

	PERIOD ACTUAL	YTD ACTUAL	BUDGET	UNEXPENDED	PCNT
<u>REVENUE</u>					
22-37-100 INTEREST EARNINGS	.00	.00	.00	.00	.0
22-37-200 IMPACT FEES	1,330.00	11,305.00	40,000.00	28,695.00	28.3
TOTAL REVENUE	1,330.00	11,305.00	40,000.00	28,695.00	28.3
<u>CONTRIBUTIONS & TRANSFERS</u>					
22-39-900 FUND BAL TO BE APPROPRIATED	.00	.00	112,000.00	112,000.00	.0
TOTAL CONTRIBUTIONS & TRANSFERS	.00	.00	112,000.00	112,000.00	.0
TOTAL FUND REVENUE	1,330.00	11,305.00	152,000.00	140,695.00	7.4

SOUTH WEBER CITY CORPORATION
 EXPENDITURES WITH COMPARISON TO BUDGET
 FOR THE 3 MONTHS ENDING SEPTEMBER 30, 2019

STORM SEWER IMPACT FEE FUND

	PERIOD ACTUAL	YTD ACTUAL	BUDGET	UNEXPENDED	PCNT
<u>EXPENDITURES</u>					
22-40-760 PROJECTS	.00	.00	7,000.00	7,000.00	.0
22-40-799 FACILITIES	.00	.00	.00	.00	.0
TOTAL EXPENDITURES	.00	.00	7,000.00	7,000.00	.0
<u>DEPARTMENT 80</u>					
22-80-800 TRANSFERS	.00	.00	145,000.00	145,000.00	.0
TOTAL DEPARTMENT 80	.00	.00	145,000.00	145,000.00	.0
TOTAL FUND EXPENDITURES	.00	.00	152,000.00	152,000.00	.0
NET REVENUE OVER EXPENDITURES	1,330.00	11,305.00	.00	(11,305.00)	.0

SOUTH WEBER CITY CORPORATION
 REVENUES WITH COMPARISON TO BUDGET
 FOR THE 3 MONTHS ENDING SEPTEMBER 30, 2019

PARK IMPACT FEE FUND

	PERIOD ACTUAL	YTD ACTUAL	BUDGET	UNEXPENDED	PCNT
<u>REVENUE</u>					
23-37-100 INTEREST EARNINGS	.00	.00	1,000.00	1,000.00	.0
23-37-200 IMPACT FEES	6,288.00	41,920.00	80,000.00	38,080.00	52.4
TOTAL REVENUE	6,288.00	41,920.00	81,000.00	39,080.00	51.8
<u>CONTRIBUTIONS & TRANSFERS</u>					
23-39-900 FUND BAL TO BE APPROPRIATED	.00	.00	79,000.00	79,000.00	.0
TOTAL CONTRIBUTIONS & TRANSFERS	.00	.00	79,000.00	79,000.00	.0
TOTAL FUND REVENUE	6,288.00	41,920.00	160,000.00	118,080.00	26.2

SOUTH WEBER CITY CORPORATION
 EXPENDITURES WITH COMPARISON TO BUDGET
 FOR THE 3 MONTHS ENDING SEPTEMBER 30, 2019

PARK IMPACT FEE FUND

	PERIOD ACTUAL	YTD ACTUAL	BUDGET	UNEXPENDED	PCNT
<u>EXPENDITURES</u>					
23-40-760 PROJECTS	.00	.00	160,000.00	160,000.00	.0
23-40-900 TRANSFER TO FUND BALANCE	.00	.00	.00	.00	.0
TOTAL EXPENDITURES	.00	.00	160,000.00	160,000.00	.0
TOTAL FUND EXPENDITURES	.00	.00	160,000.00	160,000.00	.0
NET REVENUE OVER EXPENDITURES	6,288.00	41,920.00	.00	(41,920.00)	.0

SOUTH WEBER CITY CORPORATION
REVENUES WITH COMPARISON TO BUDGET
FOR THE 3 MONTHS ENDING SEPTEMBER 30, 2019

ROAD IMPACT FEE FUND

	PERIOD ACTUAL	YTD ACTUAL	BUDGET	UNEXPENDED	PCNT
<u>REVENUE</u>					
24-37-100 INTEREST EARNINGS	.00	.00	.00	.00	.0
24-37-200 IMPACT FEES	5,373.63	30,313.15	40,000.00	9,686.85	75.8
TOTAL REVENUE	5,373.63	30,313.15	40,000.00	9,686.85	75.8
<u>CONTRIBUTIONS & TRANSFERS</u>					
24-39-500 CONTRIBUTION FROM FUND BAL	.00	.00	210,000.00	210,000.00	.0
24-39-900 FUND BAL TO BE APPROPRIATED	.00	.00	.00	.00	.0
TOTAL CONTRIBUTIONS & TRANSFERS	.00	.00	210,000.00	210,000.00	.0
TOTAL FUND REVENUE	5,373.63	30,313.15	250,000.00	219,686.85	12.1

SOUTH WEBER CITY CORPORATION
 EXPENDITURES WITH COMPARISON TO BUDGET
 FOR THE 3 MONTHS ENDING SEPTEMBER 30, 2019

ROAD IMPACT FEE FUND

	PERIOD ACTUAL	YTD ACTUAL	BUDGET	UNEXPENDED	PCNT
<u>EXPENDITURES</u>					
24-40-760 PROJECTS	.00	.00	250,000.00	250,000.00	.0
24-40-799 FACILITIES	.00	.00	.00	.00	.0
24-40-900 TRANSFER TO FUND BALANCE	.00	.00	.00	.00	.0
TOTAL EXPENDITURES	.00	.00	250,000.00	250,000.00	.0
TOTAL FUND EXPENDITURES	.00	.00	250,000.00	250,000.00	.0
NET REVENUE OVER EXPENDITURES	5,373.63	30,313.15	.00	(30,313.15)	.0

SOUTH WEBER CITY CORPORATION
 REVENUES WITH COMPARISON TO BUDGET
 FOR THE 3 MONTHS ENDING SEPTEMBER 30, 2019

WATER IMPACT FEE FUND

	PERIOD ACTUAL	YTD ACTUAL	BUDGET	UNEXPENDED	PCNT
<u>REVENUE</u>					
26-37-100 INTEREST EARNINGS	.00	.00	1,000.00	1,000.00	.0
26-37-200 IMPACT FEES	3,705.00	24,640.00	100,000.00	75,360.00	24.6
TOTAL REVENUE	3,705.00	24,640.00	101,000.00	76,360.00	24.4
<u>CONTRIBUTIONS & TRANSFERS</u>					
26-39-900 FND BALANCE TO BE APPROPRIATED	.00	.00	69,000.00	69,000.00	.0
TOTAL CONTRIBUTIONS & TRANSFERS	.00	.00	69,000.00	69,000.00	.0
TOTAL FUND REVENUE	3,705.00	24,640.00	170,000.00	145,360.00	14.5

SOUTH WEBER CITY CORPORATION
 EXPENDITURES WITH COMPARISON TO BUDGET
 FOR THE 3 MONTHS ENDING SEPTEMBER 30, 2019

WATER IMPACT FEE FUND

	PERIOD ACTUAL	YTD ACTUAL	BUDGET	UNEXPENDED	PCNT
<u>DEPARTMENT 40</u>					
26-40-760 PROJECTS	.00	.00	.00	.00	.0
26-40-799 FACILITIES	.00	.00	.00	.00	.0
TOTAL DEPARTMENT 40	.00	.00	.00	.00	.0
<u>TRANSFERS</u>					
26-80-800 TRANSFERS	.00	.00	170,000.00	170,000.00	.0
TOTAL TRANSFERS	.00	.00	170,000.00	170,000.00	.0
TOTAL FUND EXPENDITURES	.00	.00	170,000.00	170,000.00	.0
NET REVENUE OVER EXPENDITURES	3,705.00	24,640.00	.00	(24,640.00)	.0

SOUTH WEBER CITY CORPORATION
 REVENUES WITH COMPARISON TO BUDGET
 FOR THE 3 MONTHS ENDING SEPTEMBER 30, 2019

RECREATION IMPACT FEE FUND

	PERIOD ACTUAL	YTD ACTUAL	BUDGET	UNEXPENDED	PCNT
<u>REVENUE</u>					
27-37-100 INTEREST EARNINGS	.00	.00	1,000.00	1,000.00	.0
27-37-200 IMPACT FEES	2,502.00	16,680.00	65,000.00	48,320.00	25.7
TOTAL REVENUE	2,502.00	16,680.00	66,000.00	49,320.00	25.3
<u>CONTRIBUTIONS & TRANSFERS</u>					
27-39-470 TRANSFER FROM OTHER FUNDS	.00	.00	.00	.00	.0
27-39-900 FUND BAL TO BE APPROPRIATED	.00	.00	.00	.00	.0
TOTAL CONTRIBUTIONS & TRANSFERS	.00	.00	.00	.00	.0
TOTAL FUND REVENUE	2,502.00	16,680.00	66,000.00	49,320.00	25.3

SOUTH WEBER CITY CORPORATION
 EXPENDITURES WITH COMPARISON TO BUDGET
 FOR THE 3 MONTHS ENDING SEPTEMBER 30, 2019

RECREATION IMPACT FEE FUND

	PERIOD ACTUAL	YTD ACTUAL	BUDGET	UNEXPENDED	PCNT
<u>EXPENDITURES</u>					
27-40-760 PROJECTS	.00	.00	.00	.00	.0
27-40-799 FACILITIES	.00	.00	.00	.00	.0
TOTAL EXPENDITURES	.00	.00	.00	.00	.0
<u>DEPARTMENT 80</u>					
27-80-800 TRANSFERS	.00	.00	66,000.00	66,000.00	.0
TOTAL DEPARTMENT 80	.00	.00	66,000.00	66,000.00	.0
TOTAL FUND EXPENDITURES	.00	.00	66,000.00	66,000.00	.0
NET REVENUE OVER EXPENDITURES	2,502.00	16,680.00	.00	(16,680.00)	.0

SOUTH WEBER CITY CORPORATION
 REVENUES WITH COMPARISON TO BUDGET
 FOR THE 3 MONTHS ENDING SEPTEMBER 30, 2019

PUBLIC SAFETY IMPACT FEE FUND

	PERIOD ACTUAL	YTD ACTUAL	BUDGET	UNEXPENDED	PCNT
<u>REVENUE</u>					
29-37-100 INTEREST EARNINGS	.00	.00	.00	.00	.0
29-37-200 IMPACT FEES	378.00	2,520.00	10,000.00	7,480.00	25.2
TOTAL REVENUE	378.00	2,520.00	10,000.00	7,480.00	25.2
<u>CONTRIBUTIONS & TRANSFERS</u>					
29-39-470 TRANSFER FROM OTHER FUNDS	.00	.00	.00	.00	.0
29-39-900 FUND BAL TO BE APPROPRIATED	.00	.00	.00	.00	.0
TOTAL CONTRIBUTIONS & TRANSFERS	.00	.00	.00	.00	.0
TOTAL FUND REVENUE	378.00	2,520.00	10,000.00	7,480.00	25.2

SOUTH WEBER CITY CORPORATION
 EXPENDITURES WITH COMPARISON TO BUDGET
 FOR THE 3 MONTHS ENDING SEPTEMBER 30, 2019

PUBLIC SAFETY IMPACT FEE FUND

	PERIOD ACTUAL	YTD ACTUAL	BUDGET	UNEXPENDED	PCNT
<u>EXPENDITURES</u>					
29-40-760 PROJECTS	.00	.00	.00	.00	.0
29-40-799 FACILITIES	.00	.00	.00	.00	.0
TOTAL EXPENDITURES	.00	.00	.00	.00	.0
<u>DEPARTMENT 80</u>					
29-80-800 TRANSFERS	.00	.00	10,000.00	10,000.00	.0
TOTAL DEPARTMENT 80	.00	.00	10,000.00	10,000.00	.0
TOTAL FUND EXPENDITURES	.00	.00	10,000.00	10,000.00	.0
NET REVENUE OVER EXPENDITURES	378.00	2,520.00	.00	(2,520.00)	.0

SOUTH WEBER CITY CORPORATION
REVENUES WITH COMPARISON TO BUDGET
FOR THE 3 MONTHS ENDING SEPTEMBER 30, 2019

CAPITAL PROJECTS FUND

	PERIOD ACTUAL	YTD ACTUAL	BUDGET	UNEXPENDED	PCNT
<u>SOURCE 31</u>					
45-31-300 SALES AND USE TAX	.00	.00	200,000.00	200,000.00	.0
TOTAL SOURCE 31	.00	.00	200,000.00	200,000.00	.0
<u>INTERGOVERNMENTAL REVENUE</u>					
45-33-400 STATE GRANTS	.00	.00	.00	.00	.0
TOTAL INTERGOVERNMENTAL REVENUE	.00	.00	.00	.00	.0
<u>CHARGES FOR SERVICES</u>					
45-34-435 DONATIONS - CMP RAIL ROAD	.00	.00	.00	.00	.0
45-34-440 CONTRIBUTIONS	232,500.00	257,500.00	827,000.00	569,500.00	31.1
45-34-445 CONTRIBUTIONS - RESTRICTED	.00	.00	.00	.00	.0
TOTAL CHARGES FOR SERVICES	232,500.00	257,500.00	827,000.00	569,500.00	31.1
<u>MISCELLANEOUS REVENUE</u>					
45-36-100 INTEREST EARNINGS	.00	.00	8,000.00	8,000.00	.0
45-36-110 SALE OF PROPERTY	.00	.00	.00	.00	.0
TOTAL MISCELLANEOUS REVENUE	.00	.00	8,000.00	8,000.00	.0
<u>CONTRIBUTIONS AND TRANSFERS</u>					
45-39-380 FUND SURPLUS-UNRESTRICTED	.00	.00	.00	.00	.0
45-39-470 TRANSFER FROM OTHER FUNDS	.00	.00	.00	.00	.0
45-39-500 FUND BALANCE TO BE APPROPRIATE	.00	.00	.00	.00	.0
45-39-800 TRANSFER FROM IMPACT FEES	.00	.00	395,000.00	395,000.00	.0
45-39-810 TRANSFER FROM CLASS "C"	.00	.00	500,000.00	500,000.00	.0
45-39-900 FUND BAL TO BE APPROPRIATED	.00	.00	680,000.00	680,000.00	.0
TOTAL CONTRIBUTIONS AND TRANSFERS	.00	.00	1,575,000.00	1,575,000.00	.0
TOTAL FUND REVENUE	232,500.00	257,500.00	2,610,000.00	2,352,500.00	9.9

SOUTH WEBER CITY CORPORATION
EXPENDITURES WITH COMPARISON TO BUDGET
FOR THE 3 MONTHS ENDING SEPTEMBER 30, 2019

CAPITAL PROJECTS FUND

	PERIOD ACTUAL	YTD ACTUAL	BUDGET	UNEXPENDED	PCNT
45-43-740 EQUIPMENT	.00	.00	.00	.00	.0
TOTAL DEPARTMENT 43	.00	.00	.00	.00	.0
<u>DEPARTMENT 57</u>					
45-57-720 BUILDINGS	.00	.00	30,000.00	30,000.00	.0
45-57-740 EQUIPMENT	.00	.00	85,000.00	85,000.00	.0
TOTAL DEPARTMENT 57	.00	.00	115,000.00	115,000.00	.0
<u>DEPARTMENT 60</u>					
45-60-710 LAND	.00	.00	.00	.00	.0
45-60-720 1040BUILDINGS	.00	.00	800,000.00	800,000.00	.0
45-60-730 STREETS-IMP OTHER THAN BLDG	571,657.68	822,551.19	1,391,000.00	568,448.81	59.1
45-60-740 EQUIPMENT	.00	.00	34,000.00	34,000.00	.0
TOTAL DEPARTMENT 60	571,657.68	822,551.19	2,225,000.00	1,402,448.81	37.0
<u>DEPARTMENT 70</u>					
45-70-710 LAND	.00	.00	.00	.00	.0
45-70-730 IMPROVEMENTS OTHER THAN BLDGS	.00	.00	145,000.00	145,000.00	.0
45-70-740 EQUIPMENT	.00	.00	125,000.00	125,000.00	.0
TOTAL DEPARTMENT 70	.00	.00	270,000.00	270,000.00	.0
<u>DEPARTMENT 90</u>					
45-90-850 TRANSFER TO TRANS. UTIL. FUND	.00	.00	.00	.00	.0
45-90-900 TRANSFER TO FUND BALANCE	.00	.00	.00	.00	.0
TOTAL DEPARTMENT 90	.00	.00	.00	.00	.0
TOTAL FUND EXPENDITURES	571,657.68	822,551.19	2,610,000.00	1,787,448.81	31.5
NET REVENUE OVER EXPENDITURES	(339,157.68)	(565,051.19)	.00	565,051.19	.0

SOUTH WEBER CITY CORPORATION
REVENUES WITH COMPARISON TO BUDGET
FOR THE 3 MONTHS ENDING SEPTEMBER 30, 2019

WATER UTILITY FUND

	PERIOD ACTUAL	YTD ACTUAL	BUDGET	UNEXPENDED	PCNT
<u>MISCELLANEOUS REVENUE</u>					
51-36-100 INTEREST EARNINGS	.00	.00	15,000.00	15,000.00	.0
51-36-300 MISC UTILITY REVENUE	325.00	1,050.00	.00	(1,050.00)	.0
TOTAL MISCELLANEOUS REVENUE	325.00	1,050.00	15,000.00	13,950.00	7.0
<u>WATER UTILITIES REVENUE</u>					
51-37-100 WATER SALES	118,871.28	370,225.50	1,500,000.00	1,129,774.50	24.7
51-37-105 WATER CONNECTION FEE	795.00	5,300.00	16,000.00	10,700.00	33.1
51-37-130 PENALTIES	4,095.00	10,920.00	39,000.00	28,080.00	28.0
TOTAL WATER UTILITIES REVENUE	123,761.28	386,445.50	1,555,000.00	1,168,554.50	24.9
<u>SOURCE 38</u>					
51-38-820 CONTRIBUTIONS FROM IMPACT FEES	.00	.00	110,000.00	110,000.00	.0
51-38-900 SUNDRY REVENUES	.00	.00	.00	.00	.0
51-38-910 CAPITAL CONTRIBUTIONS	.00	.00	20,000.00	20,000.00	.0
51-38-920 GAIN/LOSS ON SALE OF ASSETS	.00	.00	.00	.00	.0
TOTAL SOURCE 38	.00	.00	130,000.00	130,000.00	.0
<u>CONTRIBUTIONS AND TRANSFERS</u>					
51-39-470 TRANSFER FROM OTHER FUNDS	.00	.00	.00	.00	.0
51-39-900 FUND BAL TO BE APPROPRIATED	.00	.00	989,000.00	989,000.00	.0
TOTAL CONTRIBUTIONS AND TRANSFERS	.00	.00	989,000.00	989,000.00	.0
TOTAL FUND REVENUE	124,086.28	387,495.50	2,689,000.00	2,301,504.50	14.4

SOUTH WEBER CITY CORPORATION
EXPENDITURES WITH COMPARISON TO BUDGET
FOR THE 3 MONTHS ENDING SEPTEMBER 30, 2019

WATER UTILITY FUND

	PERIOD ACTUAL	YTD ACTUAL	BUDGET	UNEXPENDED	PCNT
<u>EXPENDITURES</u>					
51-40-110 FULL-TIME EMPLOYEE SALARIES	12,177.05	27,960.11	96,000.00	68,039.89	29.1
51-40-120 PART-TIME EMPLOYEE SALARIES	.00	.00	.00	.00	.0
51-40-130 EMPLOYEE BENEFIT - RETIREMENT	2,214.43	5,298.29	23,000.00	17,701.71	23.0
51-40-131 EMPLOYEE BENEFIT-EMPLOYER FICA	906.43	2,083.22	8,000.00	5,916.78	26.0
51-40-133 EMPLOYEE BENEFIT - WORK. COMP.	314.12	751.89	3,000.00	2,248.11	25.1
51-40-134 EMPLOYEE BENEFIT - UI	.00	.00	1,400.00	1,400.00	.0
51-40-135 EMPLOYEE BENEFIT - HEALTH INS.	3,007.47	6,691.51	36,000.00	29,308.49	18.6
51-40-137 EMPLOYEE TESTING	.00	.00	.00	.00	.0
51-40-140 UNIFORMS	58.00	256.84	900.00	643.16	28.5
51-40-210 BOOKS/SUBSCRIPTIONS/MEMBERSHIP	.00	.00	1,600.00	1,600.00	.0
51-40-230 TRAVEL & TRAINING	.00	.00	1,500.00	1,500.00	.0
51-40-240 OFFICE SUPPLIES & EXPENSE	173.53	245.09	1,800.00	1,554.91	13.6
51-40-250 EQUIPMENT SUPPLIES & MAINT.	324.86	848.89	25,000.00	24,151.11	3.4
51-40-255 VEHICLE LEASE	.00	.00	.00	.00	.0
51-40-256 FUEL EXPENSE	1,012.31	1,333.18	2,000.00	666.82	66.7
51-40-260 BUILDINGS & GROUNDS MAINT.	.00	.00	10,000.00	10,000.00	.0
51-40-262 GENERAL GOVERNMENT BUILDINGS	.00	.00	.00	.00	.0
51-40-270 UTILITIES	1,124.68	2,332.29	24,000.00	21,667.71	9.7
51-40-280 TELEPHONE	174.06	370.08	2,000.00	1,629.92	18.5
51-40-312 PROFESSIONAL & TECH. - ENGINR	764.75	2,249.50	70,000.00	67,750.50	3.2
51-40-318 PROFESSIONAL TECHNICAL	.00	.00	2,200.00	2,200.00	.0
51-40-350 SOFTWARE MAINTENANCE	1,179.10	1,693.20	7,000.00	5,306.80	24.2
51-40-370 UTILITY BILLING	1,984.28	3,094.91	11,000.00	7,905.09	28.1
51-40-480 SPECIAL WATER SUPPLIES	4,470.20	7,924.99	7,000.00	(924.99)	113.2
51-40-481 WATER PURCHASES	.00	.00	313,000.00	313,000.00	.0
51-40-483 EMERGENCY LEAKS & REPAIRS	.00	.00	.00	.00	.0
51-40-485 FIRE HYDRANT UPDATE	.00	.00	50,000.00	50,000.00	.0
51-40-490 O & M CHARGE	26,326.45	35,917.72	74,000.00	38,082.28	48.5
51-40-495 METER REPLACEMENTS	.00	.00	50,000.00	50,000.00	.0
51-40-530 INTEREST EXPENSE	.00	.00	120,600.00	120,600.00	.0
51-40-550 BANKING CHARGES	140.90	242.82	7,000.00	6,757.18	3.5
51-40-650 DEPRECIATION	.00	.00	235,000.00	235,000.00	.0
51-40-730 IMPROVEMENTS OTHER THAN BLDGS	2,831.19	16,825.97	1,055,000.00	1,038,174.03	1.6
51-40-740 EQUIPMENT	.00	.00	250,000.00	250,000.00	.0
51-40-750 CAPITAL OUTLAY - VEHICLES	.00	.00	45,000.00	45,000.00	.0
51-40-811 BOND PRINCIPAL	.00	.00	95,000.00	95,000.00	.0
51-40-900 TRANSFER TO FUND BALANCE	.00	.00	.00	.00	.0
51-40-915 TRANSFER TO ADMIN SERVICES	.00	.00	61,000.00	61,000.00	.0
51-40-950 CONTRI. TO FUND BALANCE - RSRV	.00	.00	.00	.00	.0
TOTAL EXPENDITURES	59,183.81	116,120.50	2,689,000.00	2,572,879.50	4.3
<u>DEPARTMENT 80</u>					
51-80-512 CONTRIBUTIONS	.00	.00	.00	.00	.0
TOTAL DEPARTMENT 80	.00	.00	.00	.00	.0

SOUTH WEBER CITY CORPORATION
 EXPENDITURES WITH COMPARISON TO BUDGET
 FOR THE 3 MONTHS ENDING SEPTEMBER 30, 2019

WATER UTILITY FUND

	<u>PERIOD ACTUAL</u>	<u>YTD ACTUAL</u>	<u>BUDGET</u>	<u>UNEXPENDED</u>	<u>PCNT</u>
TOTAL FUND EXPENDITURES	59,183.81	116,120.50	2,689,000.00	2,572,879.50	4.3
NET REVENUE OVER EXPENDITURES	<u>64,902.47</u>	<u>271,375.00</u>	<u>.00</u>	<u>(271,375.00)</u>	<u>.0</u>

SOUTH WEBER CITY CORPORATION
REVENUES WITH COMPARISON TO BUDGET
FOR THE 3 MONTHS ENDING SEPTEMBER 30, 2019

SEWER UTILITY FUND

	PERIOD ACTUAL	YTD ACTUAL	BUDGET	UNEXPENDED	PCNT
<u>MISCELLANEOUS REVENUE</u>					
52-36-100 INTEREST EARNINGS	.00	.00	25,000.00	25,000.00	.0
TOTAL MISCELLANEOUS REVENUE	.00	.00	25,000.00	25,000.00	.0
<u>SEWER UTILITIES REVENUE</u>					
52-37-300 SEWER SALES	78,234.33	234,978.66	900,000.00	665,021.34	26.1
52-37-360 CWDIS 5% RETAINAGE	359.25	2,388.80	10,000.00	7,611.20	23.9
52-37-400 CWSID SEWER CONN FEES PAYABLE	.00	.00	.00	.00	.0
TOTAL SEWER UTILITIES REVENUE	78,593.58	237,367.46	910,000.00	672,632.54	26.1
<u>SOURCE 38</u>					
52-38-820 CONTRIBUTION FROM IMPACT FEES	.00	.00	150,000.00	150,000.00	.0
52-38-910 CAPITAL CONTRIBUTIONS	.00	.00	18,000.00	18,000.00	.0
52-38-920 GAIN/LOSS ON SALE OF ASSETS	.00	.00	.00	.00	.0
TOTAL SOURCE 38	.00	.00	168,000.00	168,000.00	.0
<u>SOURCE 39</u>					
52-39-900 FUND BAL TO BE APPROPRIATED	.00	.00	858,000.00	858,000.00	.0
TOTAL SOURCE 39	.00	.00	858,000.00	858,000.00	.0
TOTAL FUND REVENUE	78,593.58	237,367.46	1,961,000.00	1,723,632.54	12.1

SOUTH WEBER CITY CORPORATION
EXPENDITURES WITH COMPARISON TO BUDGET
FOR THE 3 MONTHS ENDING SEPTEMBER 30, 2019

SEWER UTILITY FUND

	PERIOD ACTUAL	YTD ACTUAL	BUDGET	UNEXPENDED	PCNT
<u>EXPENDITURES</u>					
52-40-110 FULL-TIME EMPLOYEE SALARIES	5,206.28	12,095.65	44,000.00	31,904.35	27.5
52-40-120 PART-TIME EMPLOYEE SALARIES	.00	.00	.00	.00	.0
52-40-130 EMPLOYEE BENEFIT - RETIREMENT	903.43	2,269.35	11,000.00	8,730.65	20.6
52-40-131 EMPLOYEE BENEFIT-EMPLOYER FICA	388.07	901.80	4,000.00	3,098.20	22.6
52-40-133 EMPLOYEE BENEFIT - WORK. COMP.	113.58	277.90	2,000.00	1,722.10	13.9
52-40-134 EMPLOYEE BENEFIT - UI	.00	.00	1,000.00	1,000.00	.0
52-40-135 EMPLOYEE BENEFIT - HEALTH INS.	654.18	1,503.90	14,000.00	12,496.10	10.7
52-40-140 UNIFORMS	28.96	128.31	900.00	771.69	14.3
52-40-210 BOOKS/SUBSCRIPTIONS/MEMBERSHIP	.00	.00	.00	.00	.0
52-40-230 TRAVEL & TRAINING	.00	.00	3,000.00	3,000.00	.0
52-40-240 OFFICE SUPPLIES & EXPENSE	173.53	245.09	1,000.00	754.91	24.5
52-40-250 EQUIPMENT SUPPLIES & MAINT.	245.40	245.40	5,000.00	4,754.60	4.9
52-40-255 VEHICLE LEASE	.00	.00	.00	.00	.0
52-40-260 BUILDINGS & GROUNDS MAINT.	.00	.00	.00	.00	.0
52-40-270 UTILITIES	38.45	70.68	500.00	429.32	14.1
52-40-312 PROFESSIONAL & TECH. - ENGINR	.00	847.50	6,000.00	5,152.50	14.1
52-40-350 SOFTWARE MAINTENANCE	179.10	693.20	2,000.00	1,306.80	34.7
52-40-370 UTILITY BILLING	1,389.70	2,166.14	7,000.00	4,833.86	30.9
52-40-490 O & M CHARGE	.00	26.48	60,000.00	59,973.52	.0
52-40-491 SEWER TREATMENT FEE	112,712.00	112,712.00	460,000.00	347,288.00	24.5
52-40-496 CONNECTION FEE - CWSID	.00	.00	.00	.00	.0
52-40-530 INTEREST EXPENSE	.00	.00	.00	.00	.0
52-40-550 BANKING CHARGES	80.51	138.75	4,000.00	3,861.25	3.5
52-40-650 DEPRECIATION	.00	.00	130,000.00	130,000.00	.0
52-40-690 PROJECTS	.00	.00	958,000.00	958,000.00	.0
52-40-900 TRANSFER TO FUND BALANCE	.00	.00	.00	.00	.0
52-40-915 TRANSFER TO ADMIN SERVICES	.00	.00	41,600.00	41,600.00	.0
52-40-950 CONTRI. TO FUND BALANCE - RSRV	.00	.00	206,000.00	206,000.00	.0
TOTAL EXPENDITURES	122,113.19	134,322.15	1,961,000.00	1,826,677.85	6.9
<u>TRANSFERS AND CONTRIBUTIONS</u>					
52-80-512 CONTRIBUTIONS	.00	.00	.00	.00	.0
TOTAL TRANSFERS AND CONTRIBUTIONS	.00	.00	.00	.00	.0
TOTAL FUND EXPENDITURES	122,113.19	134,322.15	1,961,000.00	1,826,677.85	6.9
NET REVENUE OVER EXPENDITURES	(43,519.61)	103,045.31	.00	(103,045.31)	.0

SOUTH WEBER CITY CORPORATION
REVENUES WITH COMPARISON TO BUDGET
FOR THE 3 MONTHS ENDING SEPTEMBER 30, 2019

SANITATION UTILITY FUND

	PERIOD ACTUAL	YTD ACTUAL	BUDGET	UNEXPENDED	PCNT
<u>MISCELLANEOUS REVENUE</u>					
53-36-100 INTEREST EARNINGS	.00	.00	3,000.00	3,000.00	.0
TOTAL MISCELLANEOUS REVENUE	.00	.00	3,000.00	3,000.00	.0
<u>SANITATION UTILITIES REVENUE</u>					
53-37-700 SANITATION FEES	38,419.34	115,202.05	450,000.00	334,797.95	25.6
TOTAL SANITATION UTILITIES REVENUE	38,419.34	115,202.05	450,000.00	334,797.95	25.6
<u>SOURCE 38</u>					
53-38-920 GAIN/LOSS ON SALE OF ASSETS	.00	.00	.00	.00	.0
TOTAL SOURCE 38	.00	.00	.00	.00	.0
<u>SOURCE 39</u>					
53-39-900 FUND BAL TO BE APPROPRIATED	.00	.00	.00	.00	.0
TOTAL SOURCE 39	.00	.00	.00	.00	.0
TOTAL FUND REVENUE	38,419.34	115,202.05	453,000.00	337,797.95	25.4

SOUTH WEBER CITY CORPORATION
EXPENDITURES WITH COMPARISON TO BUDGET
FOR THE 3 MONTHS ENDING SEPTEMBER 30, 2019

SANITATION UTILITY FUND

	PERIOD ACTUAL	YTD ACTUAL	BUDGET	UNEXPENDED	PCNT
<u>EXPENDITURES</u>					
53-40-110 FULL-TIME EMPLOYEE SALARIES	1,358.60	3,102.39	10,000.00	6,897.61	31.0
53-40-120 PART-TIME EMPLOYEE SALARIES	.00	.00	.00	.00	.0
53-40-130 EMPLOYEE BENEFIT - RETIREMENT	254.61	593.31	3,000.00	2,406.69	19.8
53-40-131 EMPLOYEE BENEFIT-EMPLOYER FICA	100.65	231.30	800.00	568.70	28.9
53-40-133 EMPLOYEE BENEFIT - WORK. COMP.	33.99	81.62	300.00	218.38	27.2
53-40-134 EMPLOYEE BENEFIT - UI	.00	.00	200.00	200.00	.0
53-40-135 EMPLOYEE BENEFIT - HEALTH INS.	344.13	616.25	4,000.00	3,383.75	15.4
53-40-140 UNIFORMS	.00	.00	900.00	900.00	.0
53-40-240 OFFICE SUPPLIES & EXPENSE	.00	.00	.00	.00	.0
53-40-250 EQUIPMENT SUPPLIES & MAINT.	.00	6,325.65	12,000.00	5,674.35	52.7
53-40-251 VEHICLE MAINT & SUPPLIES	.00	.00	.00	.00	.0
53-40-255 VEHICLE LEASE	.00	.00	.00	.00	.0
53-40-350 SOFTWARE MAINTENANCE	179.10	358.20	2,500.00	2,141.80	14.3
53-40-370 UTILITY BILLING	584.43	920.84	5,000.00	4,079.16	18.4
53-40-492 SANITATION FEE CHARGES	31,115.94	72,422.88	385,000.00	312,577.12	18.8
53-40-550 BANKING CHARGES	40.24	69.35	1,800.00	1,730.65	3.9
53-40-650 DEPRECIATION	.00	.00	.00	.00	.0
53-40-900 CONTRIBUTION TO FUND BALANCE	.00	.00	.00	.00	.0
53-40-915 TRANSFER TO ADMIN SERVICES	.00	.00	27,500.00	27,500.00	.0
TOTAL EXPENDITURES	34,011.69	84,721.79	453,000.00	368,278.21	18.7
TOTAL FUND EXPENDITURES	34,011.69	84,721.79	453,000.00	368,278.21	18.7
NET REVENUE OVER EXPENDITURES	4,407.65	30,480.26	.00	(30,480.26)	.0

SOUTH WEBER CITY CORPORATION
REVENUES WITH COMPARISON TO BUDGET
FOR THE 3 MONTHS ENDING SEPTEMBER 30, 2019

STORM SEWER UTILITY FUND

	PERIOD ACTUAL	YTD ACTUAL	BUDGET	UNEXPENDED	PCNT
<hr/>					
54-33-400 STATE GRANT	.00	.00	.00	.00	.0
TOTAL SOURCE 33	.00	.00	.00	.00	.0
<hr/>					
MISCELLANEOUS REVENUE					
54-36-100 INTEREST EARNINGS	.00	.00	10,000.00	10,000.00	.0
TOTAL MISCELLANEOUS REVENUE	.00	.00	10,000.00	10,000.00	.0
<hr/>					
STORM SEWER UTILITIES REVENUE					
54-37-450 STORM SEWER REVENUE	15,537.25	46,402.55	177,000.00	130,597.45	26.2
TOTAL STORM SEWER UTILITIES REVENUE	15,537.25	46,402.55	177,000.00	130,597.45	26.2
<hr/>					
SOURCE 38					
54-38-820 TFR FROM STORM SWR IMPACT FEE	.00	.00	152,000.00	152,000.00	.0
54-38-900 SUNDRY REVENUES	.00	.00	.00	.00	.0
54-38-910 CAPITAL CONTRIBUTIONS	.00	.00	140,000.00	140,000.00	.0
54-38-920 GAIN/LOSS ON SALE OF ASSETS	.00	.00	.00	.00	.0
TOTAL SOURCE 38	.00	.00	292,000.00	292,000.00	.0
<hr/>					
SOURCE 39					
54-39-900 FUND BAL TO BE APPROPRIATED	.00	.00	86,000.00	86,000.00	.0
TOTAL SOURCE 39	.00	.00	86,000.00	86,000.00	.0
<hr/>					
TOTAL FUND REVENUE	15,537.25	46,402.55	565,000.00	518,597.45	8.2

SOUTH WEBER CITY CORPORATION
 EXPENDITURES WITH COMPARISON TO BUDGET
 FOR THE 3 MONTHS ENDING SEPTEMBER 30, 2019

STORM SEWER UTILITY FUND

	PERIOD ACTUAL	YTD ACTUAL	BUDGET	UNEXPENDED	PCNT
<u>EXPENDITURES</u>					
54-40-110 FULL-TIME EMPLOYEE SALARIES	3,360.70	7,888.61	36,000.00	28,111.39	21.9
54-40-120 PART-TIME EMPLOYEE SALARIES	.00	.00	.00	.00	.0
54-40-130 EMPLOYEE BENEFIT - RETIREMENT	652.21	1,544.91	9,000.00	7,455.09	17.2
54-40-131 EMPLOYEE BENEFIT-EMPLOYER FICA	246.84	581.01	3,000.00	2,418.99	19.4
54-40-133 EMPLOYEE BENEFIT - WORK. COMP.	79.57	182.24	2,000.00	1,817.76	9.1
54-40-134 EMPLOYEE BENEFIT - UI	.00	.00	500.00	500.00	.0
54-40-135 EMPLOYEE BENEFIT - HEALTH INS.	1,056.09	2,277.45	17,000.00	14,722.55	13.4
54-40-140 UNIFORMS	28.96	128.31	400.00	271.69	32.1
54-40-230 TRAVEL & TRAINING	.00	.00	500.00	500.00	.0
54-40-240 OFFICE SUPPLIES & EXPENSE	.00	.00	.00	.00	.0
54-40-250 EQUIPMENT SUPPLIES & MAINT.	.00	.00	1,500.00	1,500.00	.0
54-40-255 VEHICLE LEASE	.00	.00	.00	.00	.0
54-40-256 FUEL EXPENSE	.00	.00	400.00	400.00	.0
54-40-270 UTILITIES	30.98	30.98	.00	(30.98)	.0
54-40-280 TELEPHONE	.00	.00	.00	.00	.0
54-40-312 PROFESSIONAL & TECH. - ENGINR	2,913.75	5,089.25	11,000.00	5,910.75	46.3
54-40-331 PROMOTIONS	1,155.00	1,155.00	1,500.00	345.00	77.0
54-40-350 SOFTWARE MAINTENANCE	179.10	358.20	2,100.00	1,741.80	17.1
54-40-370 UTILITY BILLING	303.99	473.84	2,100.00	1,626.16	22.6
54-40-493 STORM SEWER O & M	2,435.31	2,461.79	30,000.00	27,538.21	8.2
54-40-550 BANKING CHARGES	20.13	34.69	1,000.00	965.31	3.5
54-40-650 DEPRECIATION	.00	.00	130,000.00	130,000.00	.0
54-40-690 PROJECTS	.00	.00	296,000.00	296,000.00	.0
54-40-915 TRANSFER TO ADMIN SERVICES	.00	.00	21,000.00	21,000.00	.0
TOTAL EXPENDITURES	12,462.63	22,206.28	565,000.00	542,793.72	3.9
<u>DEPARTMENT 80</u>					
54-80-512 CONTRIBUTIONS	.00	.00	.00	.00	.0
TOTAL DEPARTMENT 80	.00	.00	.00	.00	.0
TOTAL FUND EXPENDITURES	12,462.63	22,206.28	565,000.00	542,793.72	3.9
NET REVENUE OVER EXPENDITURES	3,074.62	24,196.27	.00	(24,196.27)	.0

SOUTH WEBER CITY CORPORATION
 REVENUES WITH COMPARISON TO BUDGET
 FOR THE 3 MONTHS ENDING SEPTEMBER 30, 2019

PENALTIES UTILITY FUND

	PERIOD ACTUAL	YTD ACTUAL	BUDGET	UNEXPENDED	PCNT
<u>MISCELLANEOUS REVENUE</u>					
55-36-100 INTEREST EARNINGS	.00	.00	.00	.00	.0
TOTAL MISCELLANEOUS REVENUE	.00	.00	.00	.00	.0
<u>SOURCE 37</u>					
55-37-130 PENALTIES	.00	.00	.00	.00	.0
TOTAL SOURCE 37	.00	.00	.00	.00	.0
TOTAL FUND REVENUE	.00	.00	.00	.00	.0
NET REVENUE OVER EXPENDITURES	.00	.00	.00	.00	.0

SOUTH WEBER CITY CORPORATION
REVENUES WITH COMPARISON TO BUDGET
FOR THE 3 MONTHS ENDING SEPTEMBER 30, 2019

TRANSPORTATION UTILITY FUND

	PERIOD ACTUAL	YTD ACTUAL	BUDGET	UNEXPENDED	PCNT	
<hr/>						
56-31-305	TRANSPORTATION - LOCAL OPTION	.00	.00	62,000.00	62,000.00	.0
	TOTAL SOURCE 31	.00	.00	62,000.00	62,000.00	.0
<hr/>						
	SOURCE 33					
56-33-560	CLASS "C" ROAD ALLOTMENT	.00	57,205.73	211,500.00	154,294.27	27.1
	TOTAL SOURCE 33	.00	57,205.73	211,500.00	154,294.27	27.1
<hr/>						
	SOURCE 34					
56-34-270	DEVELOPER PMTS FOR IMPROV.	.00	.00	13,500.00	13,500.00	.0
	TOTAL SOURCE 34	.00	.00	13,500.00	13,500.00	.0
<hr/>						
	SOURCE 36					
56-36-100	INTEREST EARNINGS	.00	.00	1,000.00	1,000.00	.0
	TOTAL SOURCE 36	.00	.00	1,000.00	1,000.00	.0
<hr/>						
	SOURCE 37					
56-37-800	TRANSPORATION UTILITY FEE	33,475.59	99,626.42	380,000.00	280,373.58	26.2
	TOTAL SOURCE 37	33,475.59	99,626.42	380,000.00	280,373.58	26.2
<hr/>						
	CONTRIBUTIONS AND TRANSFERS					
56-39-091	TRANSFER FROM CAPITAL PROJECTS	.00	.00	.00	.00	.0
56-39-900	FUND BAL TO BE APPROPRIATED	.00	.00	110,000.00	110,000.00	.0
56-39-910	TRANSFER FROM CLASS "C" RES.	.00	.00	.00	.00	.0
	TOTAL CONTRIBUTIONS AND TRANSFERS	.00	.00	110,000.00	110,000.00	.0
<hr/>						
	TOTAL FUND REVENUE	33,475.59	156,832.15	778,000.00	621,167.85	20.2

SOUTH WEBER CITY CORPORATION
 EXPENDITURES WITH COMPARISON TO BUDGET
 FOR THE 3 MONTHS ENDING SEPTEMBER 30, 2019

TRANSPORTATION UTILITY FUND

	PERIOD ACTUAL	YTD ACTUAL	BUDGET	UNEXPENDED	PCNT
<u>EXPENDITURES</u>					
56-76-312 PROFESSIONAL & TECH. - ENGINR	.00	2,768.50	18,000.00	15,231.50	15.4
56-76-424 CURB AND GUTTER RESTORATION	.00	.00	50,000.00	50,000.00	.0
56-76-425 STREET SEALING	.00	.00	400,000.00	400,000.00	.0
56-76-730 STREET PROJECTS	81,710.00	81,710.00	310,000.00	228,290.00	26.4
56-76-910 TRANSFER TO CAP. PROJ. FUND	.00	.00	.00	.00	.0
56-76-990 CONTRIBUTION TO FUND BALANCE	.00	.00	.00	.00	.0
TOTAL EXPENDITURES	81,710.00	84,478.50	778,000.00	693,521.50	10.9
TOTAL FUND EXPENDITURES	81,710.00	84,478.50	778,000.00	693,521.50	10.9
NET REVENUE OVER EXPENDITURES	(48,234.41)	72,353.65	.00	(72,353.65)	.0

SOUTH WEBER CITY CORPORATION
 EXPENDITURES WITH COMPARISON TO BUDGET
 FOR THE 3 MONTHS ENDING SEPTEMBER 30, 2019

GENERAL LONG-TERM DEBT

	PERIOD ACTUAL	YTD ACTUAL	BUDGET	UNEXPENDED	PCNT
95-43-139 PENSION EXPENSE	.00	.00	.00	.00	.0
TOTAL DEPARTMENT 43	.00	.00	.00	.00	.0
 <u>DEPARTMENT 57</u>					
95-57-139 PENSION EXPENSE	.00	.00	.00	.00	.0
TOTAL DEPARTMENT 57	.00	.00	.00	.00	.0
 <u>DEPARTMENT 60</u>					
95-60-139 PUBLIC WORKS PENSION EXP.	.00	.00	.00	.00	.0
TOTAL DEPARTMENT 60	.00	.00	.00	.00	.0
 <u>DEPARTMENT 70</u>					
95-70-139 PARKS PENSION EXP.	.00	.00	.00	.00	.0
TOTAL DEPARTMENT 70	.00	.00	.00	.00	.0
 <u>DEPARTMENT 71</u>					
95-71-139 RECREATION PENSION EXP.	.00	.00	.00	.00	.0
TOTAL DEPARTMENT 71	.00	.00	.00	.00	.0
TOTAL FUND EXPENDITURES	.00	.00	.00	.00	.0
NET REVENUE OVER EXPENDITURES	.00	.00	.00	.00	.0

Report Criteria:

Report type: GL detail

Chk. Date	Check #	Payee	Inv. Date	Description	GL Account	G/L Amt	Merchant Name
09/12/19	40318	Ahlstrom, Douglas J.	08/30/19	Legal Services - August 2019	1043313	675.00	Ahlstrom, Douglas J.
Total 40318:						675.00	
09/06/19	40293	AIRGAS USA LLC	08/26/19	Airgas Calibration	1057250	79.91	AIRGAS USA LLC
Total 40293:						79.91	
09/12/19	40319	ALLRED, CHRISTOPHER F	08/30/19	Prosecution Services - August 2019	1042313	600.00	CHRISTOPHER F ALLRED
Total 40319:						600.00	
09/19/19	40348	APCO INC.	09/02/19	SCADA System - Maintenance	5140490	779.25	APCO INC.
Total 40348:						779.25	
09/06/19	40294	APPARATUS EQUIPMENT & SERVICE	08/20/19	Life Jackets (2)	1057450	490.00	APPARATUS EQUIPMENT & SERVICE
09/06/19	40294	APPARATUS EQUIPMENT & SERVICE	08/30/19	Boots (1)	1057140	289.00	APPARATUS EQUIPMENT & SERVICE
09/06/19	40294	APPARATUS EQUIPMENT & SERVICE	08/30/19	Boots (1)	1057140	293.00	APPARATUS EQUIPMENT & SERVICE
Total 40294:						1,072.00	
09/19/19	40349	AT&T MOBILITY	08/31/19	Telecom Service - August 2019	1057280	229.84	AT&T MOBILITY
09/19/19	40349	AT&T MOBILITY	08/31/19	Telecom Service - August 2019	1058250	13.24	AT&T MOBILITY
09/19/19	40349	AT&T MOBILITY	08/31/19	Telecom Service - August 2019	1060250	36.48	AT&T MOBILITY
09/19/19	40349	AT&T MOBILITY	08/31/19	Telecom Service - August 2019	1070250	13.24	AT&T MOBILITY
09/19/19	40349	AT&T MOBILITY	08/31/19	Telecom Service - August 2019	5140490	58.84	AT&T MOBILITY
09/19/19	40349	AT&T MOBILITY	08/31/19	Telecom Service - August 2019	5240490	13.24	AT&T MOBILITY
09/19/19	40349	AT&T MOBILITY	08/31/19	Telecom Service - August 2019	5440493	13.24	AT&T MOBILITY
Total 40349:						378.12	
09/12/19	40320	BELL JANITORIAL SUPPLY	09/10/19	City Hall Janitorial Supplies	1043262	224.45	BELL JANITORIAL SUPPLY
Total 40320:						224.45	
09/12/19	40321	BLUE STAKES OF UTAH	08/31/19	Blue Stakes - August 2019	5140490	152.52	BLUE STAKES OF UTAH

Chk. Date	Check #	Payee	Inv. Date	Description	GL Account	G/L Amt	Merchant Name
Total 40321:						152.52	
09/06/19	40295	Burton, Barry	08/31/19	Planner Services - August 2019	1058310	3,115.00	Barry Burton
Total 40295:						3,115.00	
09/12/19	40322	Carnnihan, Jay	09/10/19	Refund of Completion Bond SWC190617097	1021340	200.00	Carnnihan, Jay
Total 40322:						200.00	
09/30/19	20190900	CASELLE INC	09/25/19	Software Support/Maint.	1042350	59.70	CASELLE INC
09/30/19	20190900	CASELLE INC	09/25/19	Software Support/Maint.	1043350	179.10	CASELLE INC
09/30/19	20190900	CASELLE INC	09/25/19	Software Support/Maint.	1057350	59.70	CASELLE INC
09/30/19	20190900	CASELLE INC	09/25/19	Software Support/Maint.	1060350	59.70	CASELLE INC
09/30/19	20190900	CASELLE INC	09/25/19	Software Support/Maint.	1070350	59.70	CASELLE INC
09/30/19	20190900	CASELLE INC	09/25/19	Software Support/Maint.	2071350	59.70	CASELLE INC
09/30/19	20190900	CASELLE INC	09/25/19	Software Support/Maint.	5140350	179.10	CASELLE INC
09/30/19	20190900	CASELLE INC	09/25/19	Software Support/Maint.	5240350	179.10	CASELLE INC
09/30/19	20190900	CASELLE INC	09/25/19	Software Support/Maint.	5340350	179.10	CASELLE INC
09/30/19	20190900	CASELLE INC	09/25/19	Software Support/Maint.	5440350	179.10	CASELLE INC
Total 20190900:						1,194.00	
09/26/19	40386	CENTRAL WEBER SEWER IMPR DIST.	09/17/19	Qtrly Sewer Treatment Fees 2019	5240491	112,712.00	CENTRAL WEBER SEWER IMPR DIST.
Total 40386:						112,712.00	
09/26/19	40387	CENTURYLINK	09/10/19	SCADA Data Line - September 2019	5140490	58.45	CENTURYLINK
Total 40387:						58.45	
09/12/19	40323	CHEMTECH-FORD LABORATORIES	09/11/19	WATER SAMPLE TESTING	5140490	480.00	CHEMTECH-FORD LABORATORIES
Total 40323:						480.00	
09/06/19	40296	CINTAS CORPORATION	08/16/19	Safety glasses (12)	1070250	56.64	CINTAS CORPORATION
Total 40296:						56.64	

Chk. Date	Check #	Payee	Inv. Date	Description	GL Account	G/L Amt	Merchant Name
09/12/19	40324	CINTAS CORPORATION	09/10/19	First Aid - Shops - September 2019	1060250	26.75	CINTAS CORPORATION
Total 40324:						26.75	
09/19/19	40350	CINTAS CORPORATION	09/16/19	First Aid - FAC	2071241	23.26	CINTAS CORPORATION
Total 40350:						23.26	
09/26/19	40388	CINTAS CORPORATION	09/23/19	Eye Wash Station - Shops September 2019	1060260	125.48	CINTAS CORPORATION
Total 40388:						125.48	
09/06/19	40297	CINTAS CORPORATION LOC 180	08/28/19	MATS/TOWELS - 8/28/2019	1060250	13.20	CINTAS CORPORATION LOC 180
09/06/19	40297	CINTAS CORPORATION LOC 180	08/28/19	PW Uniforms - 08/28/2019	5240140	7.24	CINTAS CORPORATION LOC 180
09/06/19	40297	CINTAS CORPORATION LOC 180	08/28/19	PW Uniforms - 08/28/2019	5140140	14.50	CINTAS CORPORATION LOC 180
09/06/19	40297	CINTAS CORPORATION LOC 180	08/28/19	PW Uniforms - 08/28/2019	5440140	7.24	CINTAS CORPORATION LOC 180
09/06/19	40297	CINTAS CORPORATION LOC 180	08/28/19	PW Uniforms - 08/28/2019	1060140	14.50	CINTAS CORPORATION LOC 180
09/06/19	40297	CINTAS CORPORATION LOC 180	08/28/19	PW Uniforms - 08/28/2019	1070140	28.98	CINTAS CORPORATION LOC 180
09/06/19	40297	CINTAS CORPORATION LOC 180	08/28/19	PW Uniforms - 08/28/2019	1058140	14.50	CINTAS CORPORATION LOC 180
Total 40297:						100.16	
09/12/19	40325	CINTAS CORPORATION LOC 180	09/05/19	MATS/TOWELS - 09/05/2019	1060250	13.20	CINTAS CORPORATION LOC 180
09/12/19	40325	CINTAS CORPORATION LOC 180	09/05/19	PW Uniforms - 09/06/2019	5240140	7.24	CINTAS CORPORATION LOC 180
09/12/19	40325	CINTAS CORPORATION LOC 180	09/05/19	PW Uniforms - 09/06/2019	5140140	14.50	CINTAS CORPORATION LOC 180
09/12/19	40325	CINTAS CORPORATION LOC 180	09/05/19	PW Uniforms - 09/06/2019	5440140	7.24	CINTAS CORPORATION LOC 180
09/12/19	40325	CINTAS CORPORATION LOC 180	09/05/19	PW Uniforms - 09/06/2019	1060140	14.50	CINTAS CORPORATION LOC 180
09/12/19	40325	CINTAS CORPORATION LOC 180	09/05/19	PW Uniforms - 09/06/2019	1070140	28.98	CINTAS CORPORATION LOC 180
09/12/19	40325	CINTAS CORPORATION LOC 180	09/05/19	PW Uniforms - 09/06/2019	1058140	14.50	CINTAS CORPORATION LOC 180
09/12/19	40325	CINTAS CORPORATION LOC 180	09/11/19	MATS/TOWELS - 09/11/2019	1060250	13.20	CINTAS CORPORATION LOC 180
09/12/19	40325	CINTAS CORPORATION LOC 180	09/11/19	PW Uniforms - 09/11/2019	5240140	7.24	CINTAS CORPORATION LOC 180
09/12/19	40325	CINTAS CORPORATION LOC 180	09/11/19	PW Uniforms - 09/11/2019	5140140	14.50	CINTAS CORPORATION LOC 180
09/12/19	40325	CINTAS CORPORATION LOC 180	09/11/19	PW Uniforms - 09/11/2019	5440140	7.24	CINTAS CORPORATION LOC 180
09/12/19	40325	CINTAS CORPORATION LOC 180	09/11/19	PW Uniforms - 09/11/2019	1060140	14.50	CINTAS CORPORATION LOC 180
09/12/19	40325	CINTAS CORPORATION LOC 180	09/11/19	PW Uniforms - 09/11/2019	1070140	28.98	CINTAS CORPORATION LOC 180
09/12/19	40325	CINTAS CORPORATION LOC 180	09/11/19	PW Uniforms - 09/11/2019	1058140	14.50	CINTAS CORPORATION LOC 180
Total 40325:						200.32	
09/26/19	40389	CINTAS CORPORATION LOC 180	09/18/19	MATS/TOWELS - 09/18/2019	1060250	13.20	CINTAS CORPORATION LOC 180

Chk. Date	Check #	Payee	Inv. Date	Description	GL Account	G/L Amt	Merchant Name
09/26/19	40389	CINTAS CORPORATION LOC 180	09/18/19	PW Uniforms - 09/18/2019	5240140	7.24	CINTAS CORPORATION LOC 180
09/26/19	40389	CINTAS CORPORATION LOC 180	09/18/19	PW Uniforms - 09/18/2019	5140140	14.50	CINTAS CORPORATION LOC 180
09/26/19	40389	CINTAS CORPORATION LOC 180	09/18/19	PW Uniforms - 09/18/2019	5440140	7.24	CINTAS CORPORATION LOC 180
09/26/19	40389	CINTAS CORPORATION LOC 180	09/18/19	PW Uniforms - 09/18/2019	1060140	14.50	CINTAS CORPORATION LOC 180
09/26/19	40389	CINTAS CORPORATION LOC 180	09/18/19	PW Uniforms - 09/18/2019	1070140	28.98	CINTAS CORPORATION LOC 180
09/26/19	40389	CINTAS CORPORATION LOC 180	09/18/19	PW Uniforms - 09/18/2019	1058140	14.50	CINTAS CORPORATION LOC 180
Total 40389:						100.16	
09/26/19	40390	COLONIAL FLAG SPECIALTY CO INC	09/19/19	Flag Rotation - Memorial Park September 2019	1070261	90.00	COLONIAL FLAG SPECIALTY CO INC
Total 40390:						90.00	
09/30/19	20190901	COMCAST #8495440580141797	09/25/19	Monthly Charges - City Hall	1043280	376.81	COMCAST #8495440580141797
09/30/19	20190901	COMCAST #8495440580141797	09/25/19	Monthly Charges - Fire Station	1057280	191.50	COMCAST #8495440580141797
09/30/19	20190901	COMCAST #8495440580141797	09/25/19	Monthly Charges -Water	5140280	108.06	COMCAST #8495440580141797
09/30/19	20190901	COMCAST #8495440580141797	09/25/19	Monthly Charges - Recreation	2071280	205.87	COMCAST #8495440580141797
Total 20190901:						882.24	
09/12/19	40326	Core and Main	08/22/19	Pipe freezing kit	5140480	599.00	Core and Main
09/12/19	40326	Core and Main	08/23/19	Valve box for water leak view drive.	5140480	73.33	Core and Main
09/12/19	40326	Core and Main	08/26/19	Water leak repair clamps 887 E SWD.	5140480	819.76	Core and Main
Total 40326:						1,492.09	
09/19/19	40351	Core and Main	08/22/19	Fire hydrant pressure relief valves (3) for tank re	5140730	6,961.68	Core and Main
09/19/19	40351	Core and Main	08/26/19	Parts kits for East Tank Pressure Relief valves (5140480	1,294.72	Core and Main
09/19/19	40351	Core and Main	09/06/19	1" Couplings for copper lines	5140490	178.38	Core and Main
09/19/19	40351	Core and Main	09/06/19	1" Corp stops for water leaks	5140490	376.26	Core and Main
09/19/19	40351	Core and Main	09/11/19	Water meters (12)	5140480	4,470.20	Core and Main
09/19/19	40351	Core and Main	09/12/19	Water meters (12)	5140490	3,518.52	Core and Main
Total 40351:						16,799.76	
09/12/19	40327	DAVIS COUNTY GOVERNMENT	09/04/19	REDIWeb Activity	1043240	1.70	DAVIS COUNTY GOVERNMENT
Total 40327:						1.70	
09/19/19	40352	DAVIS COUNTY GOVERNMENT	08/31/19	Bailiff Services - August 2019	1042317	364.50	DAVIS COUNTY GOVERNMENT

Chk. Date	Check #	Payee	Inv. Date	Description	GL Account	G/L Amt	Merchant Name
09/19/19	40352	DAVIS COUNTY GOVERNMENT	09/01/19	Animal Control Services - August 2019	1054311	1,615.08	DAVIS COUNTY GOVERNMENT
Total 40352:						1,979.58	
09/26/19	40391	DAVIS COUNTY GOVERNMENT	09/03/19	Law Enforcement Services - August 2019	1054310	18,490.00	DAVIS COUNTY GOVERNMENT
09/26/19	40391	DAVIS COUNTY GOVERNMENT	09/17/19	Dispatch Fees - August 2019	1057370	652.58	DAVIS COUNTY GOVERNMENT
Total 40391:						19,142.58	
09/30/19	20190902	DAVIS COUNTY RECORDER	09/25/19	Recording Fees	1058319	12.50	DAVIS COUNTY RECORDER
Total 20190902:						12.50	
09/26/19	40392	DE LAGE LANDEN	09/21/19	COPIER MAINT AGREEMENT - SHARP	1042240	21.47	DE LAGE LANDEN
09/26/19	40392	DE LAGE LANDEN	09/21/19	COPIER MAINT AGREEMENT - SHARP	1043240	50.10	DE LAGE LANDEN
09/26/19	40392	DE LAGE LANDEN	09/21/19	COPIER MAINT AGREEMENT - SHARP	5140240	35.78	DE LAGE LANDEN
09/26/19	40392	DE LAGE LANDEN	09/21/19	COPIER MAINT AGREEMENT - SHARP	5240240	35.78	DE LAGE LANDEN
Total 40392:						143.13	
09/19/19	40353	Esplin, Larry	09/06/19	Reimbursement of Plumbing Bill caused by our	5140490	218.95	Esplin, Larry
Total 40353:						218.95	
09/12/19	40328	EXECUTECH	08/30/19	VPN Licenses	1043350	100.00	EXECUTECH
09/12/19	40328	EXECUTECH	08/30/19	Replacement PC Harddrive	1043250	123.99	EXECUTECH
Total 40328:						223.99	
09/19/19	40354	EXECUTECH	08/31/19	Antivirus, Backup, Email - Aug 2019	1043350	983.45	EXECUTECH
09/19/19	40354	EXECUTECH	08/31/19	IT Services for August 2019	1043308	715.00	EXECUTECH
Total 40354:						1,698.45	
09/19/19	40355	FREEDOM MAILING SERVICES INC.	09/07/19	Utility Billing - August 2019	5140370	513.60	FREEDOM MAILING SERVICES INC.
09/19/19	40355	FREEDOM MAILING SERVICES INC.	09/07/19	Utility Billing - August 2019	5240370	357.29	FREEDOM MAILING SERVICES INC.
09/19/19	40355	FREEDOM MAILING SERVICES INC.	09/07/19	Utility Billing - August 2019	5340370	167.48	FREEDOM MAILING SERVICES INC.
09/19/19	40355	FREEDOM MAILING SERVICES INC.	09/07/19	Utility Billing - August 2019	5440370	78.16	FREEDOM MAILING SERVICES INC.

Chk. Date	Check #	Payee	Inv. Date	Description	GL Account	G/L Amt	Merchant Name
Total 40355:						1,116.53	
09/19/19	40356	FRONTIER CORPORATION USA	08/31/19	Wetlands Restoration Plan	1070312	187.00	FRONTIER CORPORATION USA
Total 40356:						187.00	
09/26/19	40393	GRIFFIN FAST LUBE UTAH	09/12/19	Maintenance on Ford Ranger	1070261	212.06	GRIFFIN FAST LUBE UTAH
Total 40393:						212.06	
09/27/19	40403	GUILL, MICHAEL OR KIMBERLI	09/23/19	Mileage Reimbursement - Recorder Trips	1043230	52.20	GUILL, MICHAEL OR KIMBERLI
Total 40403:						52.20	
09/19/19	40357	HANSEN & ASSOCIATES	08/31/19	Construction Staking - south Bench Dr	4560730	2,562.00	HANSEN & ASSOCIATES
09/19/19	40357	HANSEN & ASSOCIATES	08/31/19	Topo & Boundary Survey - South Bench Dr	4560730	402.00	HANSEN & ASSOCIATES
Total 40357:						2,964.00	
09/19/19	40358	Henry Walker Construction LLC	09/17/19	Refund of Completion Bond SWC190401051	1021340	500.00	Henry Walker Construction LLC
Total 40358:						500.00	
09/12/19	40329	HERRICK INDUSTRIAL SUPPLY	09/10/19	Safety goggles and measuring tape	1060250	41.28	HERRICK INDUSTRIAL SUPPLY
09/12/19	40329	HERRICK INDUSTRIAL SUPPLY	09/10/19	Blue Stakes Paint	5140490	108.34	HERRICK INDUSTRIAL SUPPLY
Total 40329:						149.62	
09/12/19	40330	HIBBERT, SPENCER	09/11/19	Overpayment on Final Bill Acct: 7030702	0111750	141.38	HIBBERT, SPENCER
Total 40330:						141.38	
09/26/19	40394	INFOBYTES, INC.	09/25/19	Website Hosting - September 2019	1043308	234.14	INFOBYTES, INC.
Total 40394:						234.14	
09/19/19	40359	INTERMOUNTAIN GYM REPAIR	08/21/19	Repair of circuit exercise equipment	2071250	385.25	INTERMOUNTAIN GYM REPAIR

Chk. Date	Check #	Payee	Inv. Date	Description	GL Account	G/L Amt	Merchant Name
Total 40359:						385.25	
09/06/19	40298	INTERMOUNTAIN TESTING SERVICES	08/24/19	Soil Testing - South Bench Drive	4560730	68.60	INTERMOUNTAIN TESTING SERVICES
Total 40298:						68.60	
09/19/19	40360	Intermountain Workmed	08/31/19	DOT Physical Exam	1058137	65.00	Intermountain Workmed
Total 40360:						65.00	
09/19/19	40361	IWORQ SYSTEMS	09/03/19	Annual Fee-Code Enf & Permits	1058350	1,200.00	IWORQ SYSTEMS
09/19/19	40361	IWORQ SYSTEMS	09/03/19	Annual Fee-Fleet Mgmt & Work Mgmt	5140350	1,000.00	IWORQ SYSTEMS
Total 40361:						2,200.00	
09/12/19	40331	JOHNSON ELECTRIC	08/28/19	Pump Repair	1070261	384.95	JOHNSON ELECTRIC
Total 40331:						384.95	
09/19/19	40362	JOHNSON ELECTRIC	08/07/19	Change Electrical Services for 3 homes on Sout	4560730	8,193.00	JOHNSON ELECTRIC
Total 40362:						8,193.00	
09/19/19	40363	JONES AND ASSOCIATES	08/31/19	Potential Revisions to City Code	1058312	473.50	JONES AND ASSOCIATES
09/19/19	40363	JONES AND ASSOCIATES	08/31/19	General Engineering Assistance	1058312	437.25	JONES AND ASSOCIATES
09/19/19	40363	JONES AND ASSOCIATES	08/31/19	Project Review Meetings	1058312	1,011.50	JONES AND ASSOCIATES
09/19/19	40363	JONES AND ASSOCIATES	08/31/19	Weber Basin Aqueduct - Relocation Project	5140730	267.75	JONES AND ASSOCIATES
09/19/19	40363	JONES AND ASSOCIATES	08/31/19	Development Checklist	1058312	385.50	JONES AND ASSOCIATES
09/19/19	40363	JONES AND ASSOCIATES	08/31/19	New Street Light Policy Implementation	1060312	178.50	JONES AND ASSOCIATES
09/19/19	40363	JONES AND ASSOCIATES	08/31/19	2019 General Plan Update - General	1058312	8,943.25	JONES AND ASSOCIATES
09/19/19	40363	JONES AND ASSOCIATES	08/31/19	2019 General Plan Update - Land Use Easeme	1058312	269.00	JONES AND ASSOCIATES
09/19/19	40363	JONES AND ASSOCIATES	08/31/19	Fire Station - Rear Access Driveway to 1375 E	1057370	1,053.50	JONES AND ASSOCIATES
09/19/19	40363	JONES AND ASSOCIATES	08/31/19	CofO - General Locations	1058312	45.50	JONES AND ASSOCIATES
09/19/19	40363	JONES AND ASSOCIATES	08/31/19	CofO - Canyon Meadows Subdivision	1058312	136.50	JONES AND ASSOCIATES
09/19/19	40363	JONES AND ASSOCIATES	08/31/19	CofO - Ray Creek Estates	1058312	91.00	JONES AND ASSOCIATES
09/19/19	40363	JONES AND ASSOCIATES	08/31/19	CofO - Old Maple Farms Phases 1 & 2	1058312	91.00	JONES AND ASSOCIATES
09/19/19	40363	JONES AND ASSOCIATES	08/31/19	Street Maintenance Planning and Analysis	5676312	1,086.50	JONES AND ASSOCIATES
09/19/19	40363	JONES AND ASSOCIATES	08/31/19	Us-89 Widening and Improvements (UDOT)	1060312	59.50	JONES AND ASSOCIATES
09/19/19	40363	JONES AND ASSOCIATES	08/31/19	South Bench Drive - Construction Management	4560730	8,634.50	JONES AND ASSOCIATES

Chk. Date	Check #	Payee	Inv. Date	Description	GL Account	G/L Amt	Merchant Name
09/19/19	40363	JONES AND ASSOCIATES	08/31/19	UDOT SR-60 Mill & Overlay Project	1060312	357.00	JONES AND ASSOCIATES
09/19/19	40363	JONES AND ASSOCIATES	08/31/19	2019 SR-60 Sidewalk Project (by Skyhaven Co	4560730	59.50	JONES AND ASSOCIATES
09/19/19	40363	JONES AND ASSOCIATES	08/31/19	2019 SR-60 Sidewalk Project (by 475 E)	4560730	3,949.50	JONES AND ASSOCIATES
09/19/19	40363	JONES AND ASSOCIATES	08/31/19	2019 Street Maintenance Projects	5676312	572.25	JONES AND ASSOCIATES
09/19/19	40363	JONES AND ASSOCIATES	08/31/19	Division of Drinking Water Compliance	5140312	59.50	JONES AND ASSOCIATES
09/19/19	40363	JONES AND ASSOCIATES	08/31/19	WRRP - General	5140730	513.00	JONES AND ASSOCIATES
09/19/19	40363	JONES AND ASSOCIATES	08/31/19	WRRP - DDW Coordination	5140730	137.50	JONES AND ASSOCIATES
09/19/19	40363	JONES AND ASSOCIATES	08/31/19	WRRP - Tank Rehabilitation and Site Improvem	5140730	2,354.25	JONES AND ASSOCIATES
09/19/19	40363	JONES AND ASSOCIATES	08/31/19	EBRWR - Environmental Clearance	5140312	444.50	JONES AND ASSOCIATES
09/19/19	40363	JONES AND ASSOCIATES	08/31/19	General Storm Water Compliance	5440312	49.00	JONES AND ASSOCIATES
09/19/19	40363	JONES AND ASSOCIATES	08/31/19	2019 Capital Facilities Plan - Storm Water (CFP	5440312	227.75	JONES AND ASSOCIATES
09/19/19	40363	JONES AND ASSOCIATES	08/31/19	Sewer Model	5240312	847.50	JONES AND ASSOCIATES
09/19/19	40363	JONES AND ASSOCIATES	08/31/19	Canyon Meadows Parks - Wetlands	1070312	897.75	JONES AND ASSOCIATES
09/19/19	40363	JONES AND ASSOCIATES	08/31/19	Riverside Place Subdivision - Phases 1 & 2	1058319	29.50	JONES AND ASSOCIATES
09/19/19	40363	JONES AND ASSOCIATES	08/31/19	Old Maple Farms Subdivision - Phase 3	1058319	302.75	JONES AND ASSOCIATES
09/19/19	40363	JONES AND ASSOCIATES	08/31/19	Hidden Valley Meadows - Phase 1	1058319	136.50	JONES AND ASSOCIATES
09/19/19	40363	JONES AND ASSOCIATES	08/31/19	Hidden Valley Meadows - Phase 2	1058319	136.50	JONES AND ASSOCIATES
09/19/19	40363	JONES AND ASSOCIATES	08/31/19	Freedom Landing Townhomes - Phase 1	1058319	45.50	JONES AND ASSOCIATES
09/19/19	40363	JONES AND ASSOCIATES	08/31/19	Freedom Landing Townhomes - Phase 3	1058319	89.25	JONES AND ASSOCIATES
09/19/19	40363	JONES AND ASSOCIATES	08/31/19	Ray Creek Estates	1058319	241.50	JONES AND ASSOCIATES
09/19/19	40363	JONES AND ASSOCIATES	08/31/19	Harvest Park Subdivision - Phase 1	1058319	949.00	JONES AND ASSOCIATES
09/19/19	40363	JONES AND ASSOCIATES	08/31/19	Harvest Park Subdivision - Phase 2	1058319	200.50	JONES AND ASSOCIATES
09/19/19	40363	JONES AND ASSOCIATES	08/31/19	Sun Rays Subdivision	1058319	1,484.00	JONES AND ASSOCIATES
09/19/19	40363	JONES AND ASSOCIATES	08/31/19	Riverside RV Park Resort	1058319	297.50	JONES AND ASSOCIATES
09/19/19	40363	JONES AND ASSOCIATES	08/31/19	La Pintana	1058319	29.75	JONES AND ASSOCIATES
09/19/19	40363	JONES AND ASSOCIATES	08/31/19	Stephens Property (Mixed Use)	1058312	178.50	JONES AND ASSOCIATES
09/19/19	40363	JONES AND ASSOCIATES	08/31/19	The Lofts at Deer Run	1058319	766.75	JONES AND ASSOCIATES
09/19/19	40363	JONES AND ASSOCIATES	08/31/19	The Knolls at Fischer Lane	1058319	297.50	JONES AND ASSOCIATES
09/19/19	40363	JONES AND ASSOCIATES	08/31/19	Ray's Village	1058319	89.25	JONES AND ASSOCIATES
09/19/19	40363	JONES AND ASSOCIATES	08/31/19	Winn Property	1058312	178.50	JONES AND ASSOCIATES
09/19/19	40363	JONES AND ASSOCIATES	08/31/19	General Plans Maps	1058312	1,365.00	JONES AND ASSOCIATES
09/19/19	40363	JONES AND ASSOCIATES	08/31/19	Utility Maps - General	1058312	162.50	JONES AND ASSOCIATES
09/19/19	40363	JONES AND ASSOCIATES	08/31/19	Utility Maps - Culinary Water	5140312	441.00	JONES AND ASSOCIATES
09/19/19	40363	JONES AND ASSOCIATES	08/31/19	Utility Maps - Storm Drain	5440312	315.00	JONES AND ASSOCIATES
09/19/19	40363	JONES AND ASSOCIATES	08/31/19	Projects Maps	1058312	2,372.75	JONES AND ASSOCIATES
Total 40363:						43,742.25	
09/19/19	40364	KASTLE ROCK EXCAVATING INC	09/12/19	Culinary Water Leak Repair South Weber Drive	5140490	10,430.00	KASTLE ROCK EXCAVATING INC

Chk. Date	Check #	Payee	Inv. Date	Description	GL Account	G/L Amt	Merchant Name
Total 40364:						10,430.00	
09/12/19	40332	KEYES ADMINISTRATORS	09/01/19	HRA Fee - July 2019 - Sept. 2019	1043136	75.00	KEYES ADMINISTRATORS
Total 40332:						75.00	
09/06/19	40299	L N CURTIS	08/17/19	Structure Boots (1)	1057450	395.00	L N CURTIS
Total 40299:						395.00	
09/06/19	40300	Laprevote, Paul	08/30/19	Mileage Reimbursement - ULGT Meeting & Ban	1043230	45.82	Laprevote, Paul
09/06/19	40300	Laprevote, Paul	08/30/19	Mileage Reimbursement - Brigham City Caselle	1043230	83.52	Laprevote, Paul
Total 40300:						129.34	
09/26/19	40395	LEON POULSEN CONSTRUCTION CORP	09/09/19	2019 SR-60 Sidewalk Project Est#4	4560730	105,939.36	LEON POULSEN CONSTRUCTION CORP
Total 40395:						105,939.36	
09/19/19	40365	Lindsay Douglas Construction	09/17/19	Refund of Completion Bond SWC180530100	1021340	500.00	Lindsay Douglas Construction
Total 40365:						500.00	
09/19/19	40366	LOWES PROX	08/31/19	Ax and chemical sprayer	1060250	43.67	LOWES PROX
09/19/19	40366	LOWES PROX	08/31/19	Fire Pit for Posse Grounds	1070261	350.55	LOWES PROX
09/19/19	40366	LOWES PROX	08/31/19	Rake and parts	1070261	88.62	LOWES PROX
09/19/19	40366	LOWES PROX	08/31/19	40' Galv Pipe - Country Fair Days	1070261	158.40	LOWES PROX
09/19/19	40366	LOWES PROX	08/31/19	Case 2cycle oil and 2 push brooms	1060250	101.84	LOWES PROX
09/19/19	40366	LOWES PROX	08/31/19	Yellow Jacket traps - Country Fair Days	1070261	116.98	LOWES PROX
09/19/19	40366	LOWES PROX	08/31/19	Terminal Crimp, elec. cord and misc	1060250	72.66	LOWES PROX
Total 40366:						932.72	
09/19/19	40367	Lynn Coy and Judy Coy Revocable Trust	09/17/19	SR-60 Sidewalk Project Right of Way	4560730	3,285.15	Lynn Coy and Judy Coy Revocable Trust
Total 40367:						3,285.15	
09/06/19	40301	Mallory Safety & Supply LLC	08/30/19	Thermal Camera	1057250	74.84	Mallory Safety & Supply LLC

Chk. Date	Check #	Payee	Inv. Date	Description	GL Account	G/L Amt	Merchant Name
Total 40301:						74.84	
09/06/19	40302	MATTHEW BENDER & CO INC.	09/05/19	2019 UT Code Unannotated Full Set	1042210	518.61	MATTHEW BENDER & CO INC.
Total 40302:						518.61	
09/12/19	40333	Memcott, Bryan	09/09/19	Hours of Judicial services on 09/05/2019	1042313	93.75	Memcott, Bryan
Total 40333:						93.75	
09/19/19	40368	Miller Jacobsen Construction	09/17/19	Refund of Completion Bond SWC190626103	1021340	200.00	Miller Jacobsen Construction
Total 40368:						200.00	
09/12/19	40334	Miller, Jared or Jacqueline	09/11/19	Refund on Final Bill Acct: 11226505	0111750	260.00	Miller, Jared or Jacqueline
Total 40334:						260.00	
09/19/19	40369	Mitel	09/01/19	Telephone service October 2019	1043280	888.36	Mitel
Total 40369:						888.36	
09/12/19	40335	NATIONAL BATTERY SALES	09/04/19	Battery for truck#4	5140250	145.23	NATIONAL BATTERY SALES
Total 40335:						145.23	
09/12/19	40336	NILSON HOMES	09/05/19	Refund of Completion Bond SWC190325050	1021340	500.00	NILSON HOMES
Total 40336:						500.00	
09/19/19	40370	NILSON HOMES	09/17/19	Refund of Completion Bond SWC190408060	1021340	500.00	NILSON HOMES
Total 40370:						500.00	
09/06/19	40303	OFFICE DEPOT	08/17/19	Folders	1043240	24.15	OFFICE DEPOT
09/06/19	40303	OFFICE DEPOT	08/19/19	Toner	1043240	52.97	OFFICE DEPOT
09/06/19	40303	OFFICE DEPOT	08/19/19	Receipt Paper	1043240	8.83	OFFICE DEPOT

Chk. Date	Check #	Payee	Inv. Date	Description	GL Account	G/L Amt	Merchant Name
Total 40303:						85.95	
09/19/19	40371	OFFICE DEPOT	09/11/19	Post it notes	1043240	6.69	OFFICE DEPOT
Total 40371:						6.69	
09/26/19	40396	OFFICE DEPOT	09/18/19	Copy Paper	1043240	60.12	OFFICE DEPOT
Total 40396:						60.12	
09/06/19	40304	OREILLY AUTOMOTIVE, INC.	08/30/19	A1 Maintenance	1057250	14.98	OREILLY AUTOMOTIVE, INC.
09/06/19	40304	OREILLY AUTOMOTIVE, INC.	08/30/19	E1 Maintenance	1057250	18.98	OREILLY AUTOMOTIVE, INC.
Total 40304:						33.96	
09/19/19	40372	Ovation Development	09/17/19	Refund of Completion Bond SWC180417074	1021340	500.00	Ovation Development
Total 40372:						500.00	
09/06/19	40305	PEHP LTD PAYMENTS	08/19/19	LTD Premium - 08/19/2019 - 09/01/2019	1043135	154.95	PEHP LTD PAYMENTS
Total 40305:						154.95	
09/19/19	40373	PETERSEN, NIKKI	09/17/19	Refund of Completion Bond SWC180417076	1021340	500.00	PETERSEN, NIKKI
09/19/19	40373	PETERSEN, NIKKI	09/17/19	Refund of Completion Bond SWC190205015	1021340	500.00	PETERSEN, NIKKI
Total 40373:						1,000.00	
09/12/19	40337	PITNEY BOWES CREDIT CORP	09/10/19	qtrly maint. contract - postage machine	1043250	176.97	PITNEY BOWES CREDIT CORP
Total 40337:						176.97	
09/06/19	40306	PRAXAIR	08/21/19	Medical Oxygen	1057450	118.96	PRAXAIR
09/06/19	40306	PRAXAIR	09/01/19	Medical Oxygen	1057450	211.91	PRAXAIR
09/06/19	40306	PRAXAIR	09/01/19	Medical Oxygen	1057450	119.55	PRAXAIR
Total 40306:						450.42	
09/06/19	40307	PROTECT YOUTH SPORTS	08/31/19	Employee Background Checks (3) - Crossing G	1060137	53.85	PROTECT YOUTH SPORTS

Chk. Date	Check #	Payee	Inv. Date	Description	GL Account	G/L Amt	Merchant Name
09/06/19	40307	PROTECT YOUTH SPORTS	08/31/19	Employee Background Check (2)	1057137	35.90	PROTECT YOUTH SPORTS
09/06/19	40307	PROTECT YOUTH SPORTS	08/31/19	Employee Background Checks (2)	2071137	35.90	PROTECT YOUTH SPORTS
Total 40307:						125.65	
09/24/19	40161	Provost, Jared	V 07/22/19	Cash Bail Refund for Case #195400343	1021350	195.00	Provost, Jared
Total 40161:						195.00	
09/26/19	40397	Provost, Jared	07/22/19	Cash Bail Refund for Case #195400343	1021350	195.00	Provost, Jared
Total 40397:						195.00	
09/06/19	40308	Pure Water Partners	08/07/19	Ice Machine Lease - August 2019	1057260	300.90	Pure Water Partners
Total 40308:						300.90	
09/30/19	20190903	QUESTAR GAS COMPANY	09/25/19	Gas - Rec Shed, 1327 E	2071270	10.44	QUESTAR GAS COMPANY
09/30/19	20190903	QUESTAR GAS COMPANY	09/25/19	Gas - Pump Stn., 1591 E.	5140270	7.16	QUESTAR GAS COMPANY
09/30/19	20190903	QUESTAR GAS COMPANY	09/25/19	Gas - City Hall, 1600 E.	1043270	11.54	QUESTAR GAS COMPANY
09/30/19	20190903	QUESTAR GAS COMPANY	09/25/19	Gas - Shop, 1721 E.	1060271	29.17	QUESTAR GAS COMPANY
09/30/19	20190903	QUESTAR GAS COMPANY	09/25/19	Gas - Pump, 2701 E.	5140270	7.16	QUESTAR GAS COMPANY
09/30/19	20190903	QUESTAR GAS COMPANY	09/25/19	Gas - Fire Station, 7355 S	1057270	30.63	QUESTAR GAS COMPANY
Total 20190903:						96.10	
09/06/19	40309	RDJ SPECIALTIES INC	08/30/19	Fire Prevention Night - Pens (500)	1057240	542.42	RDJ SPECIALTIES INC
Total 40309:						542.42	
09/19/19	40374	Revco Leasing Company	09/10/19	Plotter Lease - September 2019	1058250	260.37	Revco Leasing Company
Total 40374:						260.37	
09/12/19	40338	ROBINSON WASTE SERVICES INC	09/01/19	Park & Ride Collection - September 2019	1070626	43.31	ROBINSON WASTE SERVICES INC
Total 40338:						43.31	
09/19/19	40375	ROBINSON WASTE SERVICES INC	08/31/19	Garbage Collection - August 2019	5340492	10,266.18	ROBINSON WASTE SERVICES INC

Chk. Date	Check #	Payee	Inv. Date	Description	GL Account	G/L Amt	Merchant Name
Total 40375:						10,266.18	
09/12/19	40339	ROCKY MOUNTAIN POWER	08/05/19		1070261	100.60	ROCKY MOUNTAIN POWER
Total 40339:						100.60	
09/30/19	20190904	ROCKY MOUNTAIN POWER	09/25/19	Power - #36 Street Light	1060271	24.00	ROCKY MOUNTAIN POWER
09/30/19	20190904	ROCKY MOUNTAIN POWER	09/25/19	Power - #39 Street Light	1060271	8.60	ROCKY MOUNTAIN POWER
09/30/19	20190904	ROCKY MOUNTAIN POWER	09/25/19	Power - #40 Street Light	1060271	22.54	ROCKY MOUNTAIN POWER
09/30/19	20190904	ROCKY MOUNTAIN POWER	09/25/19	Power - #41 Sprinkler	1070270	11.24	ROCKY MOUNTAIN POWER
09/30/19	20190904	ROCKY MOUNTAIN POWER	09/25/19	Power - #42 Digital Marque	1060271	123.87	ROCKY MOUNTAIN POWER
09/30/19	20190904	ROCKY MOUNTAIN POWER	09/25/19	Power - #1 VM Shop	1060271	156.54	ROCKY MOUNTAIN POWER
09/30/19	20190904	ROCKY MOUNTAIN POWER	09/25/19	Power - #2 City Hall	1043270	314.27	ROCKY MOUNTAIN POWER
09/30/19	20190904	ROCKY MOUNTAIN POWER	09/25/19	Power - #3 School Crossing	1060271	10.86	ROCKY MOUNTAIN POWER
09/30/19	20190904	ROCKY MOUNTAIN POWER	09/25/19	Power - #4 School Crossing	1060271	10.86	ROCKY MOUNTAIN POWER
09/30/19	20190904	ROCKY MOUNTAIN POWER	09/25/19	Power - #5 Cherry Farms Sprnklr	1070270	14.67	ROCKY MOUNTAIN POWER
09/30/19	20190904	ROCKY MOUNTAIN POWER	09/25/19	Power - #6 Cedar Loop Park	1070270	11.51	ROCKY MOUNTAIN POWER
09/30/19	20190904	ROCKY MOUNTAIN POWER	09/25/19	Power - #7 Sewer Lift Station	5240270	38.45	ROCKY MOUNTAIN POWER
09/30/19	20190904	ROCKY MOUNTAIN POWER	09/25/19	Power - #8 Cherry Farms Park	1070270	72.13	ROCKY MOUNTAIN POWER
09/30/19	20190904	ROCKY MOUNTAIN POWER	09/25/19	Power - #10 Hwy 89 Pump	5140270	500.49	ROCKY MOUNTAIN POWER
09/30/19	20190904	ROCKY MOUNTAIN POWER	09/25/19	Power - #11 Loock Park	1070270	11.51	ROCKY MOUNTAIN POWER
09/30/19	20190904	ROCKY MOUNTAIN POWER	09/25/19	Power - #12 Civic Center	1043270	211.36	ROCKY MOUNTAIN POWER
09/30/19	20190904	ROCKY MOUNTAIN POWER	09/25/19	Power - #13 Rec Shed	2071270	12.26	ROCKY MOUNTAIN POWER
09/30/19	20190904	ROCKY MOUNTAIN POWER	09/25/19	Power - #14 Street Lights	1060271	13.84	ROCKY MOUNTAIN POWER
09/30/19	20190904	ROCKY MOUNTAIN POWER	09/25/19	Power - #15 Street Lights	1060271	1,572.99	ROCKY MOUNTAIN POWER
09/30/19	20190904	ROCKY MOUNTAIN POWER	09/25/19	Power - #16 Street Lights	1060271	203.83	ROCKY MOUNTAIN POWER
09/30/19	20190904	ROCKY MOUNTAIN POWER	09/25/19	Power - #17 Street Lights	1060271	29.31	ROCKY MOUNTAIN POWER
09/30/19	20190904	ROCKY MOUNTAIN POWER	09/25/19	Power - #18 Street Lights	1060271	67.69	ROCKY MOUNTAIN POWER
09/30/19	20190904	ROCKY MOUNTAIN POWER	09/25/19	Power - #19 Street Lights	1060271	335.90	ROCKY MOUNTAIN POWER
09/30/19	20190904	ROCKY MOUNTAIN POWER	09/25/19	Power - #20 Street Lights	1060271	142.14	ROCKY MOUNTAIN POWER
09/30/19	20190904	ROCKY MOUNTAIN POWER	09/25/19	Power - #21 East End Wtr Tank	5140270	12.12	ROCKY MOUNTAIN POWER
09/30/19	20190904	ROCKY MOUNTAIN POWER	09/25/19	Power - #22 2020 E Hldng Pond	1070270	11.51	ROCKY MOUNTAIN POWER
09/30/19	20190904	ROCKY MOUNTAIN POWER	09/25/19	Power - #24 Cedar Cove Park	1070270	20.01	ROCKY MOUNTAIN POWER
09/30/19	20190904	ROCKY MOUNTAIN POWER	09/25/19	Power - # 31 City Well	5140270	185.81	ROCKY MOUNTAIN POWER
09/30/19	20190904	ROCKY MOUNTAIN POWER	09/25/19	Power - #26 Fire Station	1057270	452.58	ROCKY MOUNTAIN POWER
09/30/19	20190904	ROCKY MOUNTAIN POWER	09/25/19	Power - #27 Bowery	1070270	15.44	ROCKY MOUNTAIN POWER
09/30/19	20190904	ROCKY MOUNTAIN POWER	09/25/19	Power - #28 Cedar Cove Park	1070270	134.54	ROCKY MOUNTAIN POWER
09/30/19	20190904	ROCKY MOUNTAIN POWER	09/25/19	Power - #29 Byram Park	1070270	40.61	ROCKY MOUNTAIN POWER
09/30/19	20190904	ROCKY MOUNTAIN POWER	09/25/19	Power - Easton Pond	1070270	101.29	ROCKY MOUNTAIN POWER

Chk. Date	Check #	Payee	Inv. Date	Description	GL Account	G/L Amt	Merchant Name
09/30/19	20190904	ROCKY MOUNTAIN POWER	09/25/19	Power - Layton Pumpstation	5140270	411.94	ROCKY MOUNTAIN POWER
09/30/19	20190904	ROCKY MOUNTAIN POWER	09/25/19	Power - Old Fort Sprnklr	1070270	11.10	ROCKY MOUNTAIN POWER
Total 20190904:						5,317.81	
09/12/19	40340	SOUTH WEBER FIREFIGHTERS ASSOC	09/11/19	Remit Donations received for Cody Brotherson	1021355	175.26	SOUTH WEBER FIREFIGHTERS ASSOC
Total 40340:						175.26	
09/06/19	40310	STAKER PARSON MATERIALS AND CONS	08/05/19	Baseball Diamond Sand - Central Park	1070261	132.50	STAKER PARSON MATERIALS AND CONSTRUCT
09/06/19	40310	STAKER PARSON MATERIALS AND CONS	08/22/19	water leak Cedar Loop	5140490	145.12	STAKER PARSON MATERIALS AND CONSTRUCT
09/06/19	40310	STAKER PARSON MATERIALS AND CONS	08/23/19	water leak Cedar Loop	5140490	76.69	STAKER PARSON MATERIALS AND CONSTRUCT
Total 40310:						354.31	
09/12/19	40341	STAKER PARSON MATERIALS AND CONS	09/05/19	Rock for water leak 1160 E	5140490	702.18	STAKER PARSON MATERIALS AND CONSTRUCT
Total 40341:						702.18	
09/19/19	40376	STAKER PARSON MATERIALS AND CONS	09/04/19	South Bench Drive Phase 1 Est. #5	4560730	402,959.73	STAKER PARSON MATERIALS AND CONSTRUCT
09/19/19	40376	STAKER PARSON MATERIALS AND CONS	09/12/19	Storm drain repair 1200 E	5440493	103.72	STAKER PARSON MATERIALS AND CONSTRUCT
Total 40376:						403,063.45	
09/26/19	40398	STAKER PARSON MATERIALS AND CONS	09/16/19	2019 Street Maintenance Projects - Final	5676730	80,765.75	STAKER PARSON MATERIALS AND CONSTRUCT
Total 40398:						80,765.75	
09/19/19	40377	STANDARD EXAMINER	08/31/19	Truth in Taxation Notice	1043220	1,466.00	STANDARD EXAMINER
Total 40377:						1,466.00	
09/19/19	40378	Steve Austin Homes	09/18/19	Refund of Plan Check Fee Overpayment	1032290	200.00	Steve Austin Homes
Total 40378:						200.00	
09/06/19	40311	Tremea, Chris	09/02/19	Code Enforcement Shirts	1043140	63.71	Tremea, Chris
Total 40311:						63.71	

Chk. Date	Check #	Payee	Inv. Date	Description	GL Account	G/L Amt	Merchant Name
09/06/19	40312	UNIFIRST CORPORATION	08/23/19	Towels for FAC	2071241	34.65	UNIFIRST CORPORATION
Total 40312:						34.65	
09/12/19	40342	UNIFIRST CORPORATION	08/30/19	Towels for FAC	2071241	17.10	UNIFIRST CORPORATION
09/12/19	40342	UNIFIRST CORPORATION	09/06/19	Towels & Rugs for FAC	2071241	72.92	UNIFIRST CORPORATION
Total 40342:						90.02	
09/12/19	40343	UPPERCASE PRINTING INK	08/30/19	Newsletter - August 2019	5140370	90.95	UPPERCASE PRINTING INK
09/12/19	40343	UPPERCASE PRINTING INK	08/30/19	Newsletter - August 2019	5240370	64.67	UPPERCASE PRINTING INK
09/12/19	40343	UPPERCASE PRINTING INK	08/30/19	Newsletter - August 2019	5340370	20.21	UPPERCASE PRINTING INK
09/12/19	40343	UPPERCASE PRINTING INK	08/30/19	Newsletter - August 2019	5440370	14.15	UPPERCASE PRINTING INK
Total 40343:						189.98	
09/26/19	40399	UPPERCASE PRINTING INK	09/11/19	Newsletter - September 2019	5140370	602.92	UPPERCASE PRINTING INK
09/26/19	40399	UPPERCASE PRINTING INK	09/11/19	Newsletter - September 2019	5240370	428.75	UPPERCASE PRINTING INK
09/26/19	40399	UPPERCASE PRINTING INK	09/11/19	Newsletter - September 2019	5340370	133.98	UPPERCASE PRINTING INK
09/26/19	40399	UPPERCASE PRINTING INK	09/11/19	Newsletter - September 2019	5440370	93.79	UPPERCASE PRINTING INK
Total 40399:						1,259.44	
09/30/19	10803234	US BANK-VISA PAYMENT	09/30/19	Ink for Copier	2071240	81.78	Walmart
09/30/19	10803234	US BANK-VISA PAYMENT	09/30/19	Ink for Copier	2071610	135.64	SAMS CLUB/SYNCHRONY BANK
09/30/19	10803234	US BANK-VISA PAYMENT	09/30/19	Gifts for Senior Lunch	2071486	30.08	Dilly Dallys
09/30/19	10803234	US BANK-VISA PAYMENT	09/30/19	Salad for Senior Lunch	2071486	13.34	WINEGAR'S
09/30/19	10803234	US BANK-VISA PAYMENT	09/30/19	Food for Senior Lunch	2071486	23.52	Walmart
09/30/19	10803234	US BANK-VISA PAYMENT	09/30/19	Food for Davis County Crews	1057450	139.10	MCDONALD'S
09/30/19	10803234	US BANK-VISA PAYMENT	09/30/19	ULCT Annual Convention	1041230	215.00	UTAH LEAGUE OF CITIES & TOWNS
09/30/19	10803234	US BANK-VISA PAYMENT	09/30/19	Office Supplies - Conference Room	1043240	78.42	COSTCO WHOLESALE
09/30/19	10803234	US BANK-VISA PAYMENT	09/30/19	Staff Lunch	1043329	34.33	LITTLE CAESAR'S PIZZA
09/30/19	10803234	US BANK-VISA PAYMENT	09/30/19	Staff Appreciation Lunch	1043329	165.00	GENERIC TRAVEL RESTAURANT
09/30/19	10803234	US BANK-VISA PAYMENT	09/30/19	City Holiday Even Reservation	1041620	100.00	GENERIC TRAVEL RESTAURANT
09/30/19	10803234	US BANK-VISA PAYMENT	09/30/19	UCMA Fall Conference Registration	1043230	30.00	UCMA
09/30/19	10803234	US BANK-VISA PAYMENT	09/30/19	Country Fair Days Thank You	1043329	81.40	Bowman's Market
09/30/19	10803234	US BANK-VISA PAYMENT	09/30/19	City Email List	1043308	48.22	Generic Visa Purchase
09/30/19	10803234	US BANK-VISA PAYMENT	09/30/19	Silent Alarm - Court	1042740	873.61	Generic Visa Purchase
09/30/19	10803234	US BANK-VISA PAYMENT	09/30/19	Network Cables & Speakers	1043240	175.10	Best Buy
09/30/19	10803234	US BANK-VISA PAYMENT	09/30/19	Retractable Belt Stanchions - Court	1042740	273.90	Generic Visa Purchase

Chk. Date	Check #	Payee	Inv. Date	Description	GL Account	G/L Amt	Merchant Name
09/30/19	10803234	US BANK-VISA PAYMENT	09/30/19	Adobe Acrobat Pro	1058350	192.74	Generic Visa Purchase
09/30/19	10803234	US BANK-VISA PAYMENT	09/30/19	Rechargable Batteries	1043240	24.71	Best Buy
09/30/19	10803234	US BANK-VISA PAYMENT	09/30/19	Antifreeze	1057250	37.98	OREILLY AUTOMOTIVE, INC.
09/30/19	10803234	US BANK-VISA PAYMENT	09/30/19	Amazon Prime Membership	1058210	13.92	Amazon.com
09/30/19	10803234	US BANK-VISA PAYMENT	09/30/19	Jobcorps Drinks	1060250	4.12	Maverik
09/30/19	10803234	US BANK-VISA PAYMENT	09/30/19	Jobcorps Drinks	1060250	4.12	Maverik
09/30/19	10803234	US BANK-VISA PAYMENT	09/30/19	Mailboxes	1058250	7,200.00	Generic Visa Purchase
09/30/19	10803234	US BANK-VISA PAYMENT	09/30/19	West Water Tank Project	5140490	16.06	Generic Visa Purchase
09/30/19	10803234	US BANK-VISA PAYMENT	09/30/19	Amazon Prime Membership	1058210	13.93	Amazon.com
Total 108032343:						10,006.02	
09/06/19	40313	UTAH LOCAL GOVERNMENTS TRUST	08/12/19	Workers Comp Monthly Premium	1022250	1,150.99	UTAH LOCAL GOVERNMENTS TRUST
Total 40313:						1,150.99	
09/26/19	40400	UTAH LOCAL GOVERNMENTS TRUST	09/10/19	Workers Comp Monthly Premium	1022250	1,150.99	UTAH LOCAL GOVERNMENTS TRUST
Total 40400:						1,150.99	
09/06/19	40314	UTAH STATE TREASURER	09/04/19	Court Surcharge Remittance - August 2019	1035100	2,948.82	UTAH STATE TREASURER
Total 40314:						2,948.82	
09/12/19	40344	VALLEY NURSERY	08/30/19	Grass seed and topsoil	1070261	78.00	VALLEY NURSERY
Total 40344:						78.00	
09/26/19	40401	VALLEY NURSERY	09/16/19	Bark for storm sewer	5440493	200.00	VALLEY NURSERY
Total 40401:						200.00	
09/06/19	40315	VANGUARD CLEANING SYSTEMS OF U	09/01/19	Janitorial service - September 2019	1043262	280.00	VANGUARD CLEANING SYSTEMS OF U
Total 40315:						280.00	
09/19/19	40379	VERIZON WIRELESS	08/31/19	Public Works Air Card - August 2019	5140480	40.01	VERIZON WIRELESS
Total 40379:						40.01	

Chk. Date	Check #	Payee	Inv. Date	Description	GL Account	G/L Amt	Merchant Name
09/19/19	40380	WASATCH INTEGRATED WASTE MGMT	08/01/19	Garbage Collection - August 2019	5340492	20,779.20	WASATCH INTEGRATED WASTE MGMT
Total 40380:						20,779.20	
09/19/19	40381	WHITEHEAD ELECTRIC INC	09/06/19	Canyon Meadow Park 24V Relay	1070261	24.02	WHITEHEAD ELECTRIC INC
Total 40381:						24.02	
09/12/19	40345	WILKINSON SUPPLY	09/04/19	Trimmer Head	1070261	71.30	WILKINSON SUPPLY
Total 40345:						71.30	
09/19/19	40382	WILKINSON SUPPLY	09/12/19	Tires for mower	1070250	158.79	WILKINSON SUPPLY
Total 40382:						158.79	
09/06/19	40316	Wooden, Wes or Megan	08/22/19	Overpayment on Final Bill Acct 10004303	0111750	78.74	WOODEN, MEGAN
Total 40316:						78.74	
09/26/19	40402	WORKFORCE QA	08/31/19	Drug Test (2)	1057137	76.00	WORKFORCE QA
09/26/19	40402	WORKFORCE QA	08/31/19	Drug Test (3)	1060137	114.00	WORKFORCE QA
09/26/19	40402	WORKFORCE QA	08/31/19	Drug Test (2)	2071137	76.00	WORKFORCE QA
Total 40402:						266.00	
09/30/19	20190905	XPRESS BILL PAY	09/25/19	Online Payment Charges	5140370	348.16	XPRESS BILL PAY
09/30/19	20190905	XPRESS BILL PAY	09/25/19	Online Payment Charges	5240370	242.20	XPRESS BILL PAY
09/30/19	20190905	XPRESS BILL PAY	09/25/19	Online Payment Charges	5340370	113.53	XPRESS BILL PAY
09/30/19	20190905	XPRESS BILL PAY	09/25/19	Online Payment Charges	5440370	52.97	XPRESS BILL PAY
Total 20190905:						756.86	
09/06/19	40317	Yesco LLC	09/01/19	City LED Entrance Sign Repair	1043250	758.75	Yesco LLC
Total 40317:						758.75	
09/30/19	20190906	ZIONS BANK-SVS&TRANSACTION FEE	09/25/19	Banking Fees	1042550	20.13	ZIONS BANK-SVS&TRANSACTION FEE
09/30/19	20190906	ZIONS BANK-SVS&TRANSACTION FEE	09/25/19	Banking Fees	1043550	20.13	ZIONS BANK-SVS&TRANSACTION FEE
09/30/19	20190906	ZIONS BANK-SVS&TRANSACTION FEE	09/25/19	Banking Fees	1057550	20.13	ZIONS BANK-SVS&TRANSACTION FEE

Chk. Date	Check #	Payee	Inv. Date	Description	GL Account	G/L Amt	Merchant Name
09/30/19	20190906	ZIONS BANK-SVS&TRANSACTION FEE	09/25/19	Banking Fees	1060550	20.13	ZIONS BANK-SVS&TRANSACTION FEE
09/30/19	20190906	ZIONS BANK-SVS&TRANSACTION FEE	09/25/19	Banking Fees	1070550	20.13	ZIONS BANK-SVS&TRANSACTION FEE
09/30/19	20190906	ZIONS BANK-SVS&TRANSACTION FEE	09/25/19	Banking Fees	2071550	20.13	ZIONS BANK-SVS&TRANSACTION FEE
09/30/19	20190906	ZIONS BANK-SVS&TRANSACTION FEE	09/25/19	Banking Fees	5140550	140.90	ZIONS BANK-SVS&TRANSACTION FEE
09/30/19	20190906	ZIONS BANK-SVS&TRANSACTION FEE	09/25/19	Banking Fees	5240550	80.51	ZIONS BANK-SVS&TRANSACTION FEE
09/30/19	20190906	ZIONS BANK-SVS&TRANSACTION FEE	09/25/19	Banking Fees	5340550	40.24	ZIONS BANK-SVS&TRANSACTION FEE
09/30/19	20190906	ZIONS BANK-SVS&TRANSACTION FEE	09/25/19	Banking Fees	5440550	20.13	ZIONS BANK-SVS&TRANSACTION FEE
Total 20190906:						402.56	
Grand Totals:						897,929.98	

Approval Date: _____

Mayor _____

City Recorder: _____

Report Criteria:

Report type: GL detail

Chk. Date	Check #	Payee	Inv. Date	Description	GL Account	G/L Amt	Merchant Name	
10/31/19	40544	A-1 KEY SERVICE INC.	10/25/19	Keys for court office	1043262	31.50	A-1 KEY SERVICE INC.	
	Total 40544:						31.50	
10/17/19	40450	Adam or Heather Decaria	10/07/19	Overpayment on Final Bill Acct: 7032201	0111750	69.92	Adam or Heather Decaria	
	Total 40450:						69.92	
10/24/19	40519	ADAMS AVENUE PARKWAY	10/22/19	Tollbooth Acct	1057230	200.00	ADAMS AVENUE PARKWAY	
	Total 40519:						200.00	
10/17/19	40451	Ahlstrom, Douglas J.	09/30/19	Legal Services - September 2019	1043313	637.50	Ahlstrom, Douglas J.	
	Total 40451:						637.50	
10/17/19	40452	ALLRED, CHRISTOPHER F	09/30/19	Prosecution Services - September 2019	1042313	600.00	CHRISTOPHER F ALLRED	
	Total 40452:						600.00	
10/31/19	40545	ALPHAGRAPHS	10/14/19	2020 Budget (12)	1043240	465.54	ALPHAGRAPHS	
	Total 40545:						465.54	
10/17/19	40453	Amy Dickson	10/07/19	Overpayment on Final Bill Acct: 7002202	0111750	148.41	Amy Dickson	
	Total 40453:						148.41	
10/03/19	40405	Anixter Inc	09/17/19	Street Light Pendant Fixtures (22)	4560730	37,100.80	Anixter Inc	
	Total 40405:						37,100.80	
10/31/19	40546	Anixter Inc	10/23/19	Street Light Pole & base (22)	4560730	45,985.50	Anixter Inc	
	Total 40546:						45,985.50	
10/01/19	39620	APCO INC.	V 02/28/19	SCADA System - Maintenance	5140490	202.50	APCO INC.	

M = Manual Check, V = Void Check

Chk. Date	Check #	Payee	Inv. Date	Description	GL Account	G/L Amt	Merchant Name
Total 39620:						202.50	
10/03/19	40406	APCO INC.	02/28/19	SCADA System - Maintenance	5140490	202.50	APCO INC.
Total 40406:						202.50	
10/17/19	40454	AT&T MOBILITY	10/02/19	Telecom Service - September 2019	1057280	339.45	AT&T MOBILITY
10/17/19	40454	AT&T MOBILITY	10/02/19	Telecom Service - September 2019	1058250	13.24	AT&T MOBILITY
10/17/19	40454	AT&T MOBILITY	10/02/19	Telecom Service - September 2019	1060250	36.48	AT&T MOBILITY
10/17/19	40454	AT&T MOBILITY	10/02/19	Telecom Service - September 2019	1070250	13.24	AT&T MOBILITY
10/17/19	40454	AT&T MOBILITY	10/02/19	Telecom Service - September 2019	5140490	58.84	AT&T MOBILITY
10/17/19	40454	AT&T MOBILITY	10/02/19	Telecom Service - September 2019	5240490	13.24	AT&T MOBILITY
10/17/19	40454	AT&T MOBILITY	10/02/19	Telecom Service - September 2019	5340492	13.24	AT&T MOBILITY
Total 40454:						487.73	
10/31/19	40547	Barrett Business Services, Inc	10/25/19	Temporary Employment Services	1043120	80.54	Barrett Business Services, Inc
Total 40547:						80.54	
10/17/19	40455	BELL JANITORIAL SUPPLY	10/15/19		1070261	156.54	BELL JANITORIAL SUPPLY
Total 40455:						156.54	
10/17/19	40456	Big State Industrial Supply	09/26/19	Safety Glasses (24)	1060250	214.80	Big State Industrial Supply
Total 40456:						214.80	
10/03/19	40407	Birt, Parks	09/25/19	Referee	2071483	40.00	Birt, Parks
Total 40407:						40.00	
10/17/19	40457	Birt, Parks	10/01/19	Referee	2071483	48.00	Birt, Parks
10/17/19	40457	Birt, Parks	10/01/19	Referee	2071488	64.00	Birt, Parks
Total 40457:						112.00	
10/31/19	40548	Birt, Parks	10/22/19	Referee	2071488	80.00	Birt, Parks

Chk. Date	Check #	Payee	Inv. Date	Description	GL Account	G/L Amt	Merchant Name
Total 40548:						80.00	
10/03/19	40408	BLOMQUIST HALE CONSULTING INC.	09/02/19	EAP Service - September 2019	1043135	185.00	BLOMQUIST HALE CONSULTING INC.
10/03/19	40408	BLOMQUIST HALE CONSULTING INC.	10/01/19	EAP Services - October 2019	1043135	185.00	BLOMQUIST HALE CONSULTING INC.
Total 40408:						370.00	
10/17/19	40458	Blue Raven Solar	10/02/19	Refund of Completion Bond SWC190904143	1021340	200.00	Blue Raven Solar
Total 40458:						200.00	
10/03/19	40409	BLUE STAKES OF UTAH	09/30/19	Blue Stakes - September 2019	5140250	121.83	BLUE STAKES OF UTAH
Total 40409:						121.83	
10/17/19	40459	BOLT AND NUT SUPPLY	10/09/19	Roof repair at shop	1060260	331.30	BOLT AND NUT SUPPLY
10/17/19	40459	BOLT AND NUT SUPPLY	10/10/19	Parts for roof repair at shop	5140260	3.43	BOLT AND NUT SUPPLY
Total 40459:						327.87	
10/24/19	40520	BOLT AND NUT SUPPLY	10/17/19	Water Curb Markers	5140480	29.97	BOLT AND NUT SUPPLY
10/24/19	40520	BOLT AND NUT SUPPLY	10/18/19	Curb pins	5140480	59.93	BOLT AND NUT SUPPLY
Total 40520:						89.90	
10/17/19	40460	BROWN, CURTIS	10/16/19	Reimbursement for Senior Luncheon at Peterse	2071486	125.00	BROWN, CURTIS
Total 40460:						125.00	
10/17/19	40461	Burton, Barry	09/30/19	Planner Services - September 2019	1058310	1,715.00	Barry Burton
Total 40461:						1,715.00	
10/03/19	40410	CAL RANCH STORES	09/18/19	Credit for Gate Hardware Kit	5140490	32.01	CAL RANCH STORES
10/03/19	40410	CAL RANCH STORES	09/19/19	Gate for central park.	1070261	119.99	CAL RANCH STORES
Total 40410:						87.98	
10/17/19	40462	CAL RANCH STORES	09/18/19	Tube Gates (3) and Hardware for road to water	5140730	563.94	CAL RANCH STORES

Chk. Date	Check #	Payee	Inv. Date	Description	GL Account	G/L Amt	Merchant Name
10/17/19	40462	CAL RANCH STORES	10/02/19	Weed Spray	1070261	159.98	CAL RANCH STORES
Total 40462:						723.92	
10/24/19	40521	CASELLE INC	10/17/19	Check On Demand Module pmt 2 of 2	1043350	335.00	CASELLE INC
10/24/19	40521	CASELLE INC	10/17/19	Check On Demand Module pmt 2 of 2	5140350	335.00	CASELLE INC
10/24/19	40521	CASELLE INC	10/17/19	Check-on-Demand Module pmt 2 of 2	5240350	335.00	CASELLE INC
Total 40521:						1,005.00	
10/17/19	40463	CENTRAL WEBER SEWER IMPR DIST.	10/12/19	Third Quarter Impact Fees	5221365	47,900.00	CENTRAL WEBER SEWER IMPR DIST.
Total 40463:						47,900.00	
10/03/19	40411	CenturyLink	09/30/19	Safe Sidewalk Project 1725 E to 1550 E Final P	4560730	4,279.39	CenturyLink
Total 40411:						4,279.39	
10/24/19	40522	CENTURYLINK	10/01/19	SCADA Data Line - October 2019	5140490	59.12	CENTURYLINK
Total 40522:						59.12	
10/17/19	40464	CINTAS CORPORATION	10/08/19	Eye Wash Station - Shops October 2019	5140250	21.01	CINTAS CORPORATION
Total 40464:						21.01	
10/03/19	40412	CINTAS CORPORATION LOC 180	09/25/19	MATS/TOWELS - 09/25/2019	1060250	13.20	CINTAS CORPORATION LOC 180
10/03/19	40412	CINTAS CORPORATION LOC 180	09/25/19	PW Uniforms - 09/25/2019	5240140	7.24	CINTAS CORPORATION LOC 180
10/03/19	40412	CINTAS CORPORATION LOC 180	09/25/19	PW Uniforms - 09/25/2019	5140140	14.50	CINTAS CORPORATION LOC 180
10/03/19	40412	CINTAS CORPORATION LOC 180	09/25/19	PW Uniforms - 09/25/2019	5440140	7.24	CINTAS CORPORATION LOC 180
10/03/19	40412	CINTAS CORPORATION LOC 180	09/25/19	PW Uniforms - 09/25/2019	1060140	14.50	CINTAS CORPORATION LOC 180
10/03/19	40412	CINTAS CORPORATION LOC 180	09/25/19	PW Uniforms - 09/25/2019	1070140	28.98	CINTAS CORPORATION LOC 180
10/03/19	40412	CINTAS CORPORATION LOC 180	09/25/19	PW Uniforms - 09/25/2019	1058140	14.50	CINTAS CORPORATION LOC 180
Total 40412:						100.16	
10/17/19	40465	CINTAS CORPORATION LOC 180	10/02/19	MATS/TOWELS - 10/02/2019	1060250	13.20	CINTAS CORPORATION LOC 180
10/17/19	40465	CINTAS CORPORATION LOC 180	10/02/19	PW Uniforms - 10/02/2019	5240140	7.24	CINTAS CORPORATION LOC 180
10/17/19	40465	CINTAS CORPORATION LOC 180	10/02/19	PW Uniforms - 10/02/2019	5140140	14.50	CINTAS CORPORATION LOC 180
10/17/19	40465	CINTAS CORPORATION LOC 180	10/02/19	PW Uniforms - 10/02/2019	5440140	7.24	CINTAS CORPORATION LOC 180

Chk. Date	Check #	Payee	Inv. Date	Description	GL Account	G/L Amt	Merchant Name
10/17/19	40465	CINTAS CORPORATION LOC 180	10/02/19	PW Uniforms - 10/02/2019	1060140	14.50	CINTAS CORPORATION LOC 180
10/17/19	40465	CINTAS CORPORATION LOC 180	10/02/19	PW Uniforms - 10/02/2019	1070140	28.98	CINTAS CORPORATION LOC 180
10/17/19	40465	CINTAS CORPORATION LOC 180	10/02/19	PW Uniforms - 10/02/2019	1058140	14.50	CINTAS CORPORATION LOC 180
10/17/19	40465	CINTAS CORPORATION LOC 180	10/09/19	MATS/TOWELS - 10/09/2019	1060250	13.20	CINTAS CORPORATION LOC 180
10/17/19	40465	CINTAS CORPORATION LOC 180	10/09/19	PW Uniforms - 10/09/2019	5240140	7.24	CINTAS CORPORATION LOC 180
10/17/19	40465	CINTAS CORPORATION LOC 180	10/09/19	PW Uniforms - 10/09/2019	5140140	14.50	CINTAS CORPORATION LOC 180
10/17/19	40465	CINTAS CORPORATION LOC 180	10/09/19	PW Uniforms - 10/09/2019	5440140	7.24	CINTAS CORPORATION LOC 180
10/17/19	40465	CINTAS CORPORATION LOC 180	10/09/19	PW Uniforms - 10/09/2019	1060140	14.50	CINTAS CORPORATION LOC 180
10/17/19	40465	CINTAS CORPORATION LOC 180	10/09/19	PW Uniforms - 10/09/2019	1070140	28.98	CINTAS CORPORATION LOC 180
10/17/19	40465	CINTAS CORPORATION LOC 180	10/09/19	PW Uniforms - 10/09/2019	1058140	14.50	CINTAS CORPORATION LOC 180
10/17/19	40465	CINTAS CORPORATION LOC 180	10/16/19	MATS/TOWELS - 10/16/2019	1060250	13.20	CINTAS CORPORATION LOC 180
10/17/19	40465	CINTAS CORPORATION LOC 180	10/16/19	PW Uniforms - 10/16/2019	5240140	7.24	CINTAS CORPORATION LOC 180
10/17/19	40465	CINTAS CORPORATION LOC 180	10/16/19	PW Uniforms - 10/16/2019	5140140	14.50	CINTAS CORPORATION LOC 180
10/17/19	40465	CINTAS CORPORATION LOC 180	10/16/19	PW Uniforms - 10/16/2019	5440140	7.24	CINTAS CORPORATION LOC 180
10/17/19	40465	CINTAS CORPORATION LOC 180	10/16/19	PW Uniforms - 10/16/2019	1060140	14.50	CINTAS CORPORATION LOC 180
10/17/19	40465	CINTAS CORPORATION LOC 180	10/16/19	PW Uniforms - 10/16/2019	1070140	28.98	CINTAS CORPORATION LOC 180
10/17/19	40465	CINTAS CORPORATION LOC 180	10/16/19	PW Uniforms - 10/16/2019	1058140	14.50	CINTAS CORPORATION LOC 180
Total 40465:						300.48	
10/31/19	40549	CINTAS CORPORATION LOC 180	10/23/19	MATS/TOWELS - 10/23/2019	1060250	13.20	CINTAS CORPORATION LOC 180
10/31/19	40549	CINTAS CORPORATION LOC 180	10/23/19	PW Uniforms - 10/23/2019	5240140	9.88	CINTAS CORPORATION LOC 180
10/31/19	40549	CINTAS CORPORATION LOC 180	10/23/19	PW Uniforms - 10/23/2019	5140140	19.77	CINTAS CORPORATION LOC 180
10/31/19	40549	CINTAS CORPORATION LOC 180	10/23/19	PW Uniforms - 10/23/2019	5440140	9.88	CINTAS CORPORATION LOC 180
10/31/19	40549	CINTAS CORPORATION LOC 180	10/23/19	PW Uniforms - 10/23/2019	1060140	19.77	CINTAS CORPORATION LOC 180
10/31/19	40549	CINTAS CORPORATION LOC 180	10/23/19	PW Uniforms - 10/23/2019	1070140	39.52	CINTAS CORPORATION LOC 180
10/31/19	40549	CINTAS CORPORATION LOC 180	10/23/19	PW Uniforms - 10/23/2019	1058140	19.75	CINTAS CORPORATION LOC 180
Total 40549:						131.77	
10/03/19	40413	COLONIAL FLAG SPECIALTY CO INC	09/27/19	Flag Rotation - Memorial Park September 2019	1070261	117.52	COLONIAL FLAG SPECIALTY CO INC
Total 40413:						117.52	
10/17/19	40466	COLONIAL FLAG SPECIALTY CO INC	10/03/19	Flag Replacement - September 2019	1043262	31.20	COLONIAL FLAG SPECIALTY CO INC
10/17/19	40466	COLONIAL FLAG SPECIALTY CO INC	10/04/19	Flag Rotation - City Hall September 2019	1043262	37.00	COLONIAL FLAG SPECIALTY CO INC
10/17/19	40466	COLONIAL FLAG SPECIALTY CO INC	10/08/19	Flag Replacement - October 2019	1043262	31.20	COLONIAL FLAG SPECIALTY CO INC
Total 40466:						99.40	

Chk. Date	Check #	Payee	Inv. Date	Description	GL Account	G/L Amt	Merchant Name
10/03/19	40414	Core and Main	09/13/19	Pipe and repair seal for storm drain on 1200 E	5440493	346.41	Core and Main
10/03/19	40414	Core and Main	09/20/19	Water leak repair clamps.	5140490	430.96	Core and Main
Total 40414:						777.37	
10/31/19	40550	Core and Main	10/23/19	Water meters (154)	5140495	39,886.00	Core and Main
10/31/19	40550	Core and Main	10/23/19	Water meters (12)	5140480	3,540.00	Core and Main
10/31/19	40550	Core and Main	10/23/19	Water meters (12)	5140480	2,796.60	Core and Main
Total 40550:						40,629.40	
10/17/19	40467	CROWN TROPHY	10/02/19	Medals for Soccor (44)	2071482	140.36	CROWN TROPHY
10/17/19	40467	CROWN TROPHY	10/16/19	Name Plate for Judge Memmott	1042240	8.50	CROWN TROPHY
Total 40467:						148.86	
10/17/19	40468	DAVIS COUNTY GOVERNMENT	09/30/19	REDIWeb Activity	1058370	4.20	DAVIS COUNTY GOVERNMENT
10/17/19	40468	DAVIS COUNTY GOVERNMENT	09/30/19	Animal Control Services - September 2019	1054311	1,615.08	DAVIS COUNTY GOVERNMENT
10/17/19	40468	DAVIS COUNTY GOVERNMENT	09/30/19	Law Enforcement Services - September 2019	1054310	18,490.00	DAVIS COUNTY GOVERNMENT
10/17/19	40468	DAVIS COUNTY GOVERNMENT	10/02/19	Dispatch Fees - September 2019	1057370	652.58	DAVIS COUNTY GOVERNMENT
10/17/19	40468	DAVIS COUNTY GOVERNMENT	10/02/19	Bailiff Services - September 2019	1042317	389.50	DAVIS COUNTY GOVERNMENT
Total 40468:						21,151.36	
10/03/19	40415	DAVIS SCHOOL DISTRICT	09/18/19	Utilities - FAC Summer 2019	2071270	5,624.00	DAVIS SCHOOL DISTRICT
Total 40415:						5,624.00	
10/24/19	40523	DE LAGE LANDEN	11/15/19	COPIER MAINT AGREEMENT - SHARP	1042240	21.47	DE LAGE LANDEN
10/24/19	40523	DE LAGE LANDEN	11/15/19	COPIER MAINT AGREEMENT - SHARP	1043240	50.10	DE LAGE LANDEN
10/24/19	40523	DE LAGE LANDEN	11/15/19	COPIER MAINT AGREEMENT - SHARP	5140240	35.78	DE LAGE LANDEN
10/24/19	40523	DE LAGE LANDEN	11/15/19	COPIER MAINT AGREEMENT - SHARP	5240240	35.78	DE LAGE LANDEN
Total 40523:						143.13	
10/17/19	40469	Deep Blue Pools & Spas Inc.	10/02/19	Refund of Completion Bond SWC190116003	1021340	200.00	Deep Blue Pools & Spas Inc.
Total 40469:						200.00	
10/24/19	40524	DE'S KEY SERVICE	10/01/19	KEYS	5140480	26.75	DE'S KEY SERVICE

Chk. Date	Check #	Payee	Inv. Date	Description	GL Account	G/L Amt	Merchant Name
Total 40524:						26.75	
10/17/19	40470	DN Tanks	10/01/19	Westside Reservoir Rehabilitation Project Estim	5140730	134,976.00	DN Tanks
Total 40470:						134,976.00	
10/31/19	40551	DR. SUMMER GRACE DO	10/21/19	Medical Director Contract (June 2019 - August	1057370	1,000.00	DR. SUMMER GRACE DO
10/31/19	40551	DR. SUMMER GRACE DO	10/28/19	DEA License	1057370	731.00	DR. SUMMER GRACE DO
Total 40551:						1,731.00	
10/03/19	40416	DURKS PLUMBING	09/16/19	SPRINKLER PARTS - Detention Basin	5440493	8.18	DURKS PLUMBING
10/03/19	40416	DURKS PLUMBING	09/27/19	SPRINKLER PARTS	1070261	86.23	DURKS PLUMBING
10/03/19	40416	DURKS PLUMBING	09/30/19	SPRINKLER PARTS	1070261	120.91	DURKS PLUMBING
Total 40416:						215.32	
10/17/19	40471	DURKS PLUMBING	10/09/19	Parts for water PRV	5140480	7.76	DURKS PLUMBING
Total 40471:						7.76	
10/17/19	40472	ENERGY SAVERS	10/02/19	Refund of Completion Bond SWC190619098	1021340	200.00	ENERGY SAVERS
Total 40472:						200.00	
10/03/19	40417	EXECUTECH	09/19/19	Upgrade Network Wiring	1043740	1,842.00	EXECUTECH
10/03/19	40417	EXECUTECH	09/26/19	Replace hard drive	1043250	64.99	EXECUTECH
Total 40417:						1,906.99	
10/17/19	40473	EXECUTECH	09/30/19	Antivirus, Backup, Email - Sept 2019	1043350	1,010.97	EXECUTECH
10/17/19	40473	EXECUTECH	09/30/19	IT Services for September 2019	1043308	720.50	EXECUTECH
10/17/19	40473	EXECUTECH	09/30/19	Additional onsite services for last quarter	1043308	540.00	EXECUTECH
Total 40473:						2,271.47	
10/17/19	40474	FREEDOM MAILING SERVICES INC.	09/30/19	Utility Billing - September 2019	5140370	519.60	FREEDOM MAILING SERVICES INC.
10/17/19	40474	FREEDOM MAILING SERVICES INC.	09/30/19	Utility Billing - September 2019	5240370	361.46	FREEDOM MAILING SERVICES INC.
10/17/19	40474	FREEDOM MAILING SERVICES INC.	09/30/19	Utility Billing - September 2019	5340370	169.44	FREEDOM MAILING SERVICES INC.

Chk. Date	Check #	Payee	Inv. Date	Description	GL Account	G/L Amt	Merchant Name
10/17/19	40474	FREEDOM MAILING SERVICES INC.	09/30/19	Utility Billing - September 2019	5440370	79.07	FREEDOM MAILING SERVICES INC.
10/17/19	40474	FREEDOM MAILING SERVICES INC.	10/04/19	General Plan Survey Letter from Mayor	1058620	1,170.09	FREEDOM MAILING SERVICES INC.
Total 40474:						2,299.66	
10/17/19	40475	Fruit Heights City	09/30/19	Davis County Storm Coalition Annual Dues	5440331	1,155.00	Fruit Heights City
Total 40475:						1,155.00	
10/17/19	40476	GREAT BASIN TURF PRODUCTS	10/07/19	FERTILIZER	1070261	1,473.35	GREAT BASIN TURF PRODUCTS
Total 40476:						1,473.35	
10/17/19	40477	HANSEN & ASSOCIATES	10/08/19	Surveying - South Bench Drive	4560730	2,915.48	HANSEN & ASSOCIATES
10/17/19	40477	HANSEN & ASSOCIATES	10/08/19	Surveying - South Weber Trails	1070312	2,150.00	HANSEN & ASSOCIATES
Total 40477:						5,065.48	
10/03/19	40418	Henry Schein, Inc.	09/09/19	Medical Supplies - Gloves	1057450	416.32	Henry Schein, Inc.
Total 40418:						416.32	
10/31/19	40552	Henry Schein, Inc.	10/01/19	Medical Supplies	1057450	39.56	Henry Schein, Inc.
10/31/19	40552	Henry Schein, Inc.	10/01/19	Medical Supplies	1057450	87.72	Henry Schein, Inc.
10/31/19	40552	Henry Schein, Inc.	10/04/19	Glucagen Diagnostic Kits	1057450	399.98	Henry Schein, Inc.
Total 40552:						527.26	
10/03/19	40419	HERRICK INDUSTRIAL SUPPLY	09/18/19	Drill bits	5140490	148.31	HERRICK INDUSTRIAL SUPPLY
Total 40419:						148.31	
10/17/19	40478	HERRICK INDUSTRIAL SUPPLY	10/10/19	Tape measure for staff	5140480	56.00	HERRICK INDUSTRIAL SUPPLY
Total 40478:						56.00	
10/31/19	40553	HERRICK INDUSTRIAL SUPPLY	10/09/19	Building repair (lift roof back on)	1057260	884.51	HERRICK INDUSTRIAL SUPPLY
Total 40553:						884.51	

Chk. Date	Check #	Payee	Inv. Date	Description	GL Account	G/L Amt	Merchant Name
10/17/19	40479	IIMC	10/07/19	CMC Certification Admission Application Fee for	1042210	125.00	IIMC
	Total 40479:					125.00	
10/17/19	40480	INFOBYTES, INC.	10/09/19	Domain Name Renewal	1043308	50.00	INFOBYTES, INC.
	Total 40480:					50.00	
10/31/19	40554	INFOBYTES, INC.	10/25/19	Website Hosting - October 2019	1043308	234.14	INFOBYTES, INC.
	Total 40554:					234.14	
10/31/19	40555	INTERMOUNTAIN GYM REPAIR	10/23/19	Replace damaged handles	2071250	85.50	INTERMOUNTAIN GYM REPAIR
	Total 40555:					85.50	
10/17/19	40481	INTERMOUNTAIN TESTING SERVICES	10/05/19	Soil Testing - South Bench Drive	4560730	409.20	INTERMOUNTAIN TESTING SERVICES
	Total 40481:					409.20	
10/17/19	40482	Intermountain Workmed	09/19/19	1 DOT Physical	1058137	65.00	Intermountain Workmed
	Total 40482:					65.00	
10/03/19	40420	Interstate Barricades, LLC	09/19/19	STREET SIGNS	1060250	89.00	Interstate Barricades, LLC
	Total 40420:					89.00	
10/03/19	40421	JACKSON SPORTS	09/11/19	Volleyball Jerseys (47)	2071484	341.00	JACKSON SPORTS
10/03/19	40421	JACKSON SPORTS	09/11/19	Flag Football Jerseys (117)	2071483	1,063.00	JACKSON SPORTS
	Total 40421:					1,404.00	
10/03/19	40422	JOHNSON ELECTRIC	09/25/19	Pump Repair CM park	1070250	210.95	JOHNSON ELECTRIC
	Total 40422:					210.95	
10/17/19	40483	JOHNSON ELECTRIC	09/05/19	Pump Repair at CM park	1070250	148.00	JOHNSON ELECTRIC
10/17/19	40483	JOHNSON ELECTRIC	09/23/19	Street Light Repair	1060271	448.09	JOHNSON ELECTRIC

Chk. Date	Check #	Payee	Inv. Date	Description	GL Account	G/L Amt	Merchant Name
Total 40483:						596.09	
10/24/19	40525	JOHNSON ELECTRIC	10/17/19	Houma Electric Sewer Pump - Lift Station	5240490	4,100.00	JOHNSON ELECTRIC
Total 40525:						4,100.00	
10/17/19	40484	JONES AND ASSOCIATES	09/30/19	Potential Revisions to City Code	1058312	178.00	JONES AND ASSOCIATES
10/17/19	40484	JONES AND ASSOCIATES	09/30/19	General Engineering Assistance	1058312	1,130.50	JONES AND ASSOCIATES
10/17/19	40484	JONES AND ASSOCIATES	09/30/19	General City Council Meeting - Planning and Att	1058312	297.50	JONES AND ASSOCIATES
10/17/19	40484	JONES AND ASSOCIATES	09/30/19	Project Review Meetings	1058312	773.50	JONES AND ASSOCIATES
10/17/19	40484	JONES AND ASSOCIATES	09/30/19	City Standards Update	1058312	34.50	JONES AND ASSOCIATES
10/17/19	40484	JONES AND ASSOCIATES	09/30/19	Weber Basin Aqueduct - Relocation Project	5140312	59.50	JONES AND ASSOCIATES
10/17/19	40484	JONES AND ASSOCIATES	09/30/19	Development Checklist	1058312	118.00	JONES AND ASSOCIATES
10/17/19	40484	JONES AND ASSOCIATES	09/30/19	2019 General Plan Update - General	1058312	821.75	JONES AND ASSOCIATES
10/17/19	40484	JONES AND ASSOCIATES	09/30/19	CofO - Canyon Meadows Subdivision	1058312	45.50	JONES AND ASSOCIATES
10/17/19	40484	JONES AND ASSOCIATES	09/30/19	CofO - Ray Creek Estates	1058312	45.50	JONES AND ASSOCIATES
10/17/19	40484	JONES AND ASSOCIATES	09/30/19	CofO - Old Maple Farms Phases 1 & 2	1058312	136.50	JONES AND ASSOCIATES
10/17/19	40484	JONES AND ASSOCIATES	09/30/19	US-89 Farmington to I-84 (UDOT)	1060312	119.00	JONES AND ASSOCIATES
10/17/19	40484	JONES AND ASSOCIATES	09/30/19	South Bench Drive - Construction Management	4560730	16,422.00	JONES AND ASSOCIATES
10/17/19	40484	JONES AND ASSOCIATES	09/30/19	UDOT SR-60 Mill & Overlay Project	1060312	327.25	JONES AND ASSOCIATES
10/17/19	40484	JONES AND ASSOCIATES	09/30/19	2019 SR-60 Sidewalk Project (by Skyhaven Co	4560730	73.50	JONES AND ASSOCIATES
10/17/19	40484	JONES AND ASSOCIATES	09/30/19	2019 SR-60 Sidewalk Project (by 475 E)	4560730	1,597.75	JONES AND ASSOCIATES
10/17/19	40484	JONES AND ASSOCIATES	09/30/19	2019 Street Maintenance Projects	5676730	944.25	JONES AND ASSOCIATES
10/17/19	40484	JONES AND ASSOCIATES	09/30/19	2019 Safety Sidewalk Application	1060312	1,257.75	JONES AND ASSOCIATES
10/17/19	40484	JONES AND ASSOCIATES	09/30/19	Division of Drinking Water Compliance	5140312	373.25	JONES AND ASSOCIATES
10/17/19	40484	JONES AND ASSOCIATES	09/30/19	WRRP - General	5140730	110.00	JONES AND ASSOCIATES
10/17/19	40484	JONES AND ASSOCIATES	09/30/19	WRRP - Tank Rehabilitation and Slite Improvem	5140730	1,393.50	JONES AND ASSOCIATES
10/17/19	40484	JONES AND ASSOCIATES	09/30/19	EBRWR - Design	5140730	763.75	JONES AND ASSOCIATES
10/17/19	40484	JONES AND ASSOCIATES	09/30/19	Davis County Storm Water Coalition	5440312	147.00	JONES AND ASSOCIATES
10/17/19	40484	JONES AND ASSOCIATES	09/30/19	2019 Capital Facilities Plan - Storm Water	5440312	2,766.75	JONES AND ASSOCIATES
10/17/19	40484	JONES AND ASSOCIATES	09/30/19	Canyon Meadows Park - Wetlands	1070312	1,745.75	JONES AND ASSOCIATES
10/17/19	40484	JONES AND ASSOCIATES	09/30/19	View Drive Trail	1070312	164.50	JONES AND ASSOCIATES
10/17/19	40484	JONES AND ASSOCIATES	09/30/19	Bowman Old Farm Estates Subdivision	1058319	227.50	JONES AND ASSOCIATES
10/17/19	40484	JONES AND ASSOCIATES	09/30/19	Old Maple Farms Subdivision - Phases 1 & 2	1058319	59.50	JONES AND ASSOCIATES
10/17/19	40484	JONES AND ASSOCIATES	09/30/19	Old Maple Farms Subdivision - Phase 3	1058319	45.50	JONES AND ASSOCIATES
10/17/19	40484	JONES AND ASSOCIATES	09/30/19	Freedom Landing Townhomes - General	1058319	59.50	JONES AND ASSOCIATES
10/17/19	40484	JONES AND ASSOCIATES	09/30/19	Freedom Landing Phase 3	1058319	136.50	JONES AND ASSOCIATES
10/17/19	40484	JONES AND ASSOCIATES	09/30/19	Harvest Park Subdivision - Phase 1	1058319	598.50	JONES AND ASSOCIATES
10/17/19	40484	JONES AND ASSOCIATES	09/30/19	Harvest Park Subdivision - Phase 2	1058319	148.75	JONES AND ASSOCIATES

Chk. Date	Check #	Payee	Inv. Date	Description	GL Account	G/L Amt	Merchant Name
10/17/19	40484	JONES AND ASSOCIATES	09/30/19	Sun Rays Subdivision	1058319	378.00	JONES AND ASSOCIATES
10/17/19	40484	JONES AND ASSOCIATES	09/30/19	Riverside RV Park Resort	1058319	941.25	JONES AND ASSOCIATES
10/17/19	40484	JONES AND ASSOCIATES	09/30/19	The Knolls at Valley View	1058319	743.75	JONES AND ASSOCIATES
10/17/19	40484	JONES AND ASSOCIATES	09/30/19	Base Map and Database Management	1058312	79.00	JONES AND ASSOCIATES
10/17/19	40484	JONES AND ASSOCIATES	09/30/19	General Plan Maps	1058312	892.00	JONES AND ASSOCIATES
10/17/19	40484	JONES AND ASSOCIATES	09/30/19	Streets Map	1060312	276.50	JONES AND ASSOCIATES
10/17/19	40484	JONES AND ASSOCIATES	09/30/19	Utility Maps - General	5140312	202.00	JONES AND ASSOCIATES
10/17/19	40484	JONES AND ASSOCIATES	09/30/19	Utility Maps - Culinary Water	5140312	130.00	JONES AND ASSOCIATES
10/17/19	40484	JONES AND ASSOCIATES	09/30/19	Projects Map	1060312	214.75	JONES AND ASSOCIATES
Total 40484:						36,979.75	
10/24/19	40526	JONES AND ASSOCIATES	10/22/19	South Bench Drive - ROW Acquisition Past Due	4560730	1,505.00	JONES AND ASSOCIATES
Total 40526:						1,505.00	
10/31/19	40556	KASTLE ROCK EXCAVATING INC	10/22/19	Curb & Gutter repair - Easton Village	5140490	850.00	KASTLE ROCK EXCAVATING INC
Total 40556:						850.00	
10/17/19	40485	Keyes, Cameron D.	10/01/19	Referee	2071488	22.50	Keyes, Cameron D.
Total 40485:						22.50	
10/03/19	40423	L N CURTIS	09/09/19	Foam, Gloves, Hoods	1057450	2,749.00	L N CURTIS
10/03/19	40423	L N CURTIS	09/30/19	Turnouts	1057450	385.83	L N CURTIS
Total 40423:						3,134.83	
10/03/19	40424	Laprevote, Paul	10/02/19	Caselle Conference Las Vegas	1043230	181.50	Laprevote, Paul
Total 40424:						181.50	
10/17/19	40486	Laprevote, Paul	10/16/19	Caselle Conference Las Vegas Reimbursement	1043210	594.81	Laprevote, Paul
Total 40486:						594.81	
10/31/19	40557	Laprevote, Paul	10/29/19	Mileage Reimbursement	1043230	98.02	Laprevote, Paul

Chk. Date	Check #	Payee	Inv. Date	Description	GL Account	G/L Amt	Merchant Name
Total 40557:						98.02	
10/31/19	40558	LAYTON CITY CORPORATION	10/02/19	Paramedics from Layton	1057375	486.00	LAYTON CITY CORPORATION
Total 40558:						486.00	
10/03/19	40425	Leading Edge Supply Solution LLC	09/23/19	Hard Hats (10)	5140490	170.05	Leading Edge Supply Solution LLC
Total 40425:						170.05	
10/31/19	40559	Leading Edge Supply Solution LLC	10/17/19	Safety green coats(4)	5140480	345.55	Leading Edge Supply Solution LLC
Total 40559:						345.55	
10/24/19	40527	LES OLSON COMPANY	10/15/19	Quarterly Copier Maintenance	1043250	405.92	LES OLSON COMPANY
Total 40527:						405.92	
10/03/19	40426	LES SCHWAB TIRE CENTER	09/25/19	Tire repair on farm tractor.	1070250	62.74	LES SCHWAB TIRE CENTER
Total 40426:						62.74	
10/24/19	40528	LES SCHWAB TIRE CENTER	10/17/19	Backhoe Tire repair	5140250	249.99	LES SCHWAB TIRE CENTER
Total 40528:						249.99	
10/04/19	40443	Martinez, James	09/23/19	Batteries	1057240	8.56	Martinez, James
Total 40443:						8.56	
10/24/19	40529	Meagan Goodson	10/21/19	Cash Bail Refund Case 161400016	1021350	1,070.00	Meagan Goodson
Total 40529:						1,070.00	
10/04/19	40444	Memcott, Bryan	09/20/19	3 hours of Judicial Service 09/19/2019	1042313	225.00	Memcott, Bryan
Total 40444:						225.00	
10/17/19	40487	Mitel	10/01/19	Telephone service - Nov 2019	1043280	888.36	Mitel

Chk. Date	Check #	Payee	Inv. Date	Description	GL Account	G/L Amt	Merchant Name
Total 40487:						888.36	
10/17/19	40488	MOUNT OLYMPUS	10/05/19	Water Cooler for City Hall	1043262	44.58	MOUNT OLYMPUS WATER
Total 40488:						44.58	
10/17/19	40489	Murray Builders	10/02/19	Refund of Completion Bond SWC180206015	1021340	500.00	Murray Builders
Total 40489:						500.00	
10/17/19	40490	NILSON HOMES	10/02/19	Refund of Completion Bond SWC190408061	1021340	500.00	NILSON HOMES
10/17/19	40490	NILSON HOMES	10/02/19	Refund of Completion Bond SWC190501080	1021340	500.00	NILSON HOMES
10/17/19	40490	NILSON HOMES	10/10/19	Refund of Completion Bond SWC190115002	1021340	500.00	NILSON HOMES
Total 40490:						1,500.00	
10/24/19	40530	OFFICE DEPOT	10/11/19	Paper, Stamps	1043240	101.52	OFFICE DEPOT
10/24/19	40530	OFFICE DEPOT	10/12/19	Scanned Stamp	1043240	6.01	OFFICE DEPOT
10/24/19	40530	OFFICE DEPOT	10/15/19	Wall File Holder for Kim	1043240	8.83	OFFICE DEPOT
Total 40530:						116.36	
10/03/19	40427	OREILLY AUTOMOTIVE, INC.	09/24/19	5-20 oil	1070250	39.98	OREILLY AUTOMOTIVE, INC.
Total 40427:						39.98	
10/17/19	40491	OREILLY AUTOMOTIVE, INC.	10/11/19	Seafoam - Winterize Equipment	1070250	35.96	OREILLY AUTOMOTIVE, INC.
Total 40491:						35.96	
10/31/19	40560	OREILLY AUTOMOTIVE, INC.	10/26/19	Car Wash Supplies	1057250	15.48	OREILLY AUTOMOTIVE, INC.
10/31/19	40560	OREILLY AUTOMOTIVE, INC.	10/26/19	Key Chains (2)	1057250	7.98	OREILLY AUTOMOTIVE, INC.
Total 40560:						23.46	
10/17/19	40492	Ovation Development	10/02/19	Refund of Completion Bond SWC190117006	1021340	500.00	Ovation Development
10/17/19	40492	Ovation Development	10/07/19	Refund of Completion Bond SWC190117005	1021340	500.00	Ovation Development
10/17/19	40492	Ovation Development	10/07/19	Refund of Completion Bond SWC190117009	1021340	500.00	Ovation Development
10/17/19	40492	Ovation Development	10/09/19	Refund of Completion Bond SWC190117008	1021340	500.00	Ovation Development

Chk. Date	Check #	Payee	Inv. Date	Description	GL Account	G/L Amt	Merchant Name
Total 40492:						2,000.00	
10/24/19	40531	Ovation Development	10/17/19	Refund of Completion Bond SWC190225024	1021340	500.00	Ovation Development
Total 40531:						500.00	
10/31/19	40561	Ovation Development	10/29/19	Refund of Completion Bond SWC190225025	1021340	500.00	Ovation Development
10/31/19	40561	Ovation Development	10/29/19	Refund of Completion Bond SWC190225026	1021340	500.00	Ovation Development
10/31/19	40561	Ovation Development	10/29/19	Refund of Completion Bond SWC190225027	1021340	500.00	Ovation Development
10/31/19	40561	Ovation Development	10/29/19	Refund of Completion Bond SWC190225028	1021340	500.00	Ovation Development
Total 40561:						2,000.00	
10/04/19	40445	PEHP LTD PAYMENTS	09/02/19	LTD Premium - 09/02/2019 - 09/15/2019	1043135	153.76	PEHP LTD PAYMENTS
Total 40445:						153.76	
10/17/19	40493	PEHP LTD PAYMENTS	09/16/19	LTD Premium - 09/16/2019 - 09/29/2019	1043135	151.96	PEHP LTD PAYMENTS
Total 40493:						151.96	
10/31/19	40562	PEHP LTD PAYMENTS	10/01/19	LTD Premium-09/30/2019 - 10/13/2019	1043135	149.52	PEHP LTD PAYMENTS
Total 40562:						149.52	
10/31/19	40563	Pellegrini, Morgan	10/25/19	Referee	2071331	27.00	Pellegrini, Morgan
10/31/19	40563	Pellegrini, Morgan	10/25/19	Referee	2071488	36.00	Pellegrini, Morgan
Total 40563:						63.00	
10/17/19	40494	PERRY HOMES	10/02/19	Refund of Completion Bond SWC191018161	1021340	500.00	PERRY HOMES
Total 40494:						500.00	
10/17/19	40495	PIONEER RESEARCH CORPORATION	09/30/19	LIFT STATION DEGREASER	5240250	245.40	PIONEER RESEARCH CORPORATION
Total 40495:						245.40	
10/03/19	40428	PITNEY BOWES PURCHASE POWER	09/30/19	Postage for court	1042240	82.65	PITNEY BOWES PURCHASE POWER

Chk. Date	Check #	Payee	Inv. Date	Description	GL Account	G/L Amt	Merchant Name
10/03/19	40428	PITNEY BOWES PURCHASE POWER	09/30/19	Postage for Administration	1043240	192.85	PITNEY BOWES PURCHASE POWER
10/03/19	40428	PITNEY BOWES PURCHASE POWER	09/30/19	POSTAGE FOR UTILITIES	5140240	137.75	PITNEY BOWES PURCHASE POWER
10/03/19	40428	PITNEY BOWES PURCHASE POWER	09/30/19	POSTAGE FOR UTILITIES	5240240	137.75	PITNEY BOWES PURCHASE POWER
Total 40428:						551.00	
10/24/19	40532	Poll, Marci	10/22/19	Refund of Completion Bond SWC191001156	1021340	500.00	Poll, Marci
Total 40532:						500.00	
10/17/19	40496	POST ASPHALT & CONSTRUCTION	09/26/19	Water Leak - 1994 S Cedar Loop Dr	5140490	4,914.00	POST ASPHALT & CONSTRUCTION
10/17/19	40496	POST ASPHALT & CONSTRUCTION	09/26/19	Water Leak 1160 E 7473 S	5140490	2,178.75	POST ASPHALT & CONSTRUCTION
Total 40496:						7,092.75	
10/31/19	40564	PRAXAIR	10/01/19	Oxygen	1057450	120.21	PRAXAIR
Total 40564:						120.21	
10/03/19	40429	PROTECT YOUTH SPORTS	09/30/19	Employee Background Check	1057137	17.95	PROTECT YOUTH SPORTS
10/03/19	40429	PROTECT YOUTH SPORTS	09/30/19	Employee Background Check	2071137	17.95	PROTECT YOUTH SPORTS
Total 40429:						35.90	
10/07/19	40397	Provost, Jared	V 07/22/19	Cash Bail Refund for Case #195400343	1021350	195.00	Provost, Jared
Total 40397:						195.00	
10/07/19	40448	Provost, Jared	07/22/19	Cash Bail Refund for Case #195400343	1021350	195.00	Provost, Jared
Total 40448:						195.00	
10/17/19	40497	Psion Homes	10/02/19	Refund of Completion Bond SWC190227036	1021340	500.00	Psion Homes
Total 40497:						500.00	
10/24/19	40533	Pure Water Partners	10/01/19	Ice Machine Lease - September 2019	1057260	300.90	Pure Water Partners
Total 40533:						300.90	

Chk. Date	Check #	Payee	Inv. Date	Description	GL Account	G/L Amt	Merchant Name
10/31/19	40565	Pure Water Partners	10/09/19	Ice Machine Lease - October 2019	1057450	300.90	Pure Water Partners
Total 40565:						300.90	
10/03/19	40430	RDJ SPECIALTIES INC	09/03/19	Fire Prevention Night Plastic Hats	1057230	1,416.00	RDJ SPECIALTIES INC
Total 40430:						1,416.00	
10/17/19	40498	Revco Leasing Company	10/08/19	Plotter Lease - October 2019	1058250	260.37	Revco Leasing Company
Total 40498:						260.37	
10/17/19	40499	Rietbrock, Jaden	09/30/19	Referee	2071482	18.75	Rietbrock, Jaden
10/17/19	40499	Rietbrock, Jaden	09/30/19	Referee	2071483	52.50	Rietbrock, Jaden
10/17/19	40499	Rietbrock, Jaden	10/03/19	Referee	2071482	18.75	Rietbrock, Jaden
10/17/19	40499	Rietbrock, Jaden	10/03/19	Referee	2071483	15.00	Rietbrock, Jaden
10/17/19	40499	Rietbrock, Jaden	10/03/19	Referee	2071488	82.50	Rietbrock, Jaden
Total 40499:						187.50	
10/31/19	40566	Rietbrock, Jaden	10/21/19	Referee	2071480	22.50	Rietbrock, Jaden
10/31/19	40566	Rietbrock, Jaden	10/21/19	Referee	2071488	60.00	Rietbrock, Jaden
Total 40566:						82.50	
10/17/19	40500	ROBINSON WASTE SERVICES INC	09/30/19	Garbage Collection - September 2019	5340492	10,266.18	ROBINSON WASTE SERVICES INC
10/17/19	40500	ROBINSON WASTE SERVICES INC	10/01/19	Park & Ride Collection - October 2019	1070626	43.36	ROBINSON WASTE SERVICES INC
Total 40500:						10,309.54	
10/17/19	40501	ROCKY MOUNTAIN POWER	09/17/19	Pump - 310 S Kingston	5440270	30.98	ROCKY MOUNTAIN POWER
Total 40501:						30.98	
10/17/19	40502	Sargent, Jaden	09/12/19	Referee	2071482	71.25	Sargent, Jaden
10/17/19	40502	Sargent, Jaden	10/01/19	Referee	2071482	56.25	Sargent, Jaden
Total 40502:						127.50	
10/17/19	40503	SAV ON	09/05/19	Paint for marking Football fields	2071483	48.95	SAV ON

Chk. Date	Check #	Payee	Inv. Date	Description	GL Account	G/L Amt	Merchant Name
Total 40503:						48.95	
10/31/19	40567	Schenck, Kaden	10/21/19	Referee	2071480	41.25	Schenck, Kaden
Total 40567:						41.25	
10/24/19	40534	SHAFER, ANGELICA	10/17/19	Interpreter Service 10/17/2019 Case 19140002	1042610	39.80	SHAFER, ANGELICA
Total 40534:						39.80	
10/04/19	40446	Sjoblom, Jo	09/19/19	MATT Trip	1041230	89.47	Sjoblom, Jo
Total 40446:						89.47	
10/17/19	40504	SMASH ATHLETICS	09/23/19	Jerseys & Lettering for Soccer Season (60)	2071482	637.27	SMASH ATHLETICS
Total 40504:						637.27	
10/31/19	40568	SMITH AND EDWARDS COMPANY	10/30/19	Bibs(2)	1070140	210.87	SMITH AND EDWARDS COMPANY
Total 40568:						210.87	
10/17/19	40505	Smith, Lisa	10/04/19	Reimbursement for BCI TAC Conference and U	1042230	881.56	Smith, Lisa
Total 40505:						881.56	
10/24/19	40535	STAKER PARSON MATERIALS AND CONS	10/03/19	South Bench Drive Construction Phase 1 Estim	4560730	316,495.64	STAKER PARSON MATERIALS AND CONSTRU
Total 40535:						316,495.64	
10/24/19	40536	STANDARD EXAMINER	10/01/19	Public Hearing Notice - Sept 2019	1043220	81.25	STANDARD EXAMINER
Total 40536:						81.25	
10/03/19	40431	STATE OF UTAH GASCARD	09/02/19	PW2 - Mark J.	5140256	629.39	STATE OF UTAH GASCARD
10/03/19	40431	STATE OF UTAH GASCARD	09/02/19	PW3 - Bryan	5140256	248.38	STATE OF UTAH GASCARD
10/03/19	40431	STATE OF UTAH GASCARD	09/02/19	PW1- Zach	1070256	244.78	STATE OF UTAH GASCARD
10/03/19	40431	STATE OF UTAH GASCARD	09/02/19	PW1- Zach	1060256	163.19	STATE OF UTAH GASCARD
10/03/19	40431	STATE OF UTAH GASCARD	09/02/19	PW4 - 2014 Dodge	1070256	159.98	STATE OF UTAH GASCARD

Chk. Date	Check #	Payee	Inv. Date	Description	GL Account	G/L Amt	Merchant Name
10/03/19	40431	STATE OF UTAH GASCARD	09/02/19	PW4 - 2014 Dodge	1060256	106.65	STATE OF UTAH GASCARD
10/03/19	40431	STATE OF UTAH GASCARD	09/02/19	PW6 - Ranger	2071256	76.74	STATE OF UTAH GASCARD
10/03/19	40431	STATE OF UTAH GASCARD	09/02/19	PW9 - 2017 F550	1060256	174.71	STATE OF UTAH GASCARD
10/03/19	40431	STATE OF UTAH GASCARD	09/02/19	PW8 - 2016 Dump	5140256	134.54	STATE OF UTAH GASCARD
10/03/19	40431	STATE OF UTAH GASCARD	09/02/19	E1 Fuel	1057256	191.70	STATE OF UTAH GASCARD
10/03/19	40431	STATE OF UTAH GASCARD	09/02/19	E2 Fuel	1057256	50.30	STATE OF UTAH GASCARD
10/03/19	40431	STATE OF UTAH GASCARD	09/02/19	Brush2	1057256	24.49	STATE OF UTAH GASCARD
10/03/19	40431	STATE OF UTAH GASCARD	09/02/19	Amb-1 - Fuel	1057256	175.32	STATE OF UTAH GASCARD
Total 40431:						2,380.17	
10/17/19	40506	STATE OF UTAH-D.O.P.L.	10/05/19	Second Quarter State Surcharge Fees	1058370	585.90	STATE OF UTAH-D.O.P.L.
Total 40506:						585.90	
10/03/19	40432	SUNSTATE EQUIPMENT COMPANY	09/12/19	Mini Excavator Rental	5440493	527.00	SUNSTATE EQUIPMENT COMPANY
Total 40432:						527.00	
10/04/19	40447	SWEEP N UTAH	09/16/19	Street Sweep - 9/05/2019	1060410	280.00	SWEEP N UTAH
Total 40447:						280.00	
10/03/19	40433	ULINE	09/19/19	Bollards for Parking Lot - Court Security	1042740	577.54	ULINE
Total 40433:						577.54	
10/03/19	40434	UNIFIRST CORPORATION	09/20/19	Towels for FAC	2071241	34.65	UNIFIRST CORPORATION
Total 40434:						34.65	
10/17/19	40507	UNIFIRST CORPORATION	10/04/19	Towels & Rugs for FAC	2071241	72.92	UNIFIRST CORPORATION
Total 40507:						72.92	
10/17/19	40508	UPPERCASE PRINTING INK	10/09/19	Newsletter - October 2019	5140370	91.39	UPPERCASE PRINTING INK
10/17/19	40508	UPPERCASE PRINTING INK	10/09/19	Newsletter - October 2019	5240370	64.99	UPPERCASE PRINTING INK
10/17/19	40508	UPPERCASE PRINTING INK	10/09/19	Newsletter - October 2019	5340370	20.31	UPPERCASE PRINTING INK
10/17/19	40508	UPPERCASE PRINTING INK	10/09/19	Newsletter - October 2019	5440370	14.21	UPPERCASE PRINTING INK

Chk. Date	Check #	Payee	Inv. Date	Description	GL Account	G/L Amt	Merchant Name
Total 40508:						190.90	
10/31/19	40569	UPPERCASE PRINTING INK	10/09/19	General Plan Letter	1058620	311.25	UPPERCASE PRINTING INK
Total 40569:						311.25	
10/17/19	40509	US BANK	09/25/19	Admin Fee - Bond	5140490	1,650.00	US BANK
Total 40509:						1,650.00	
10/24/19	40537	UTAH LOCAL GOVERNMENTS TRUST	10/11/19	Workers Comp Monthly Premium	1022250	1,150.99	UTAH LOCAL GOVERNMENTS TRUST
Total 40537:						1,150.99	
10/03/19	40435	UTAH STATE DEQ	09/17/19	State Storm Water Permit (annual)	5440493	1,250.00	UTAH STATE DEQ
Total 40435:						1,250.00	
10/03/19	40436	UTAH STATE TREASURER	10/02/19	Court Surcharge Remittance - September 2019	1035100	2,727.52	UTAH STATE TREASURER
Total 40436:						2,727.52	
10/03/19	40437	VANGUARD CLEANING SYSTEMS OF U	10/01/19	Janitorial service - October 2019	1043262	280.00	VANGUARD CLEANING SYSTEMS OF U
Total 40437:						280.00	
10/24/19	40538	VERIZON WIRELESS	10/01/19	Public Works Air Card - October 2019	5140280	40.01	VERIZON WIRELESS
Total 40538:						40.01	
10/31/19	40570	Wasatch Front Regional Council	06/30/19	Payment Match for Weber River Trail Design	1070430	3,500.00	Wasatch Front Regional Council
Total 40570:						3,500.00	
10/03/19	40438	WASATCH INTEGRATED WASTE MGMT	09/30/19	Public Works Dump Drop off	5340492	20.16	WASATCH INTEGRATED WASTE MGMT
Total 40438:						20.16	
10/17/19	40510	WASATCH INTEGRATED WASTE MGMT	09/01/19	Garbage Disposal - September 2019	5340492	20,829.60	WASATCH INTEGRATED WASTE MGMT

Chk. Date	Check #	Payee	Inv. Date	Description	GL Account	G/L Amt	Merchant Name
Total 40510:						20,829.60	
10/17/19	40511	WEBER BASIN WATER	10/12/19	Third Quarter Impact fees - 20 permits	5121357	87,260.00	WEBER BASIN WATER
Total 40511:						87,260.00	
10/03/19	40439	WHITEHEAD ELECTRIC INC	09/18/19	cord for welder.	5140250	57.80	WHITEHEAD ELECTRIC INC
Total 40439:						57.80	
10/03/19	40440	WILKINSON SUPPLY	09/24/19	Mower repair.	1070250	1,431.76	WILKINSON SUPPLY
Total 40440:						1,431.76	
10/17/19	40512	WILKINSON SUPPLY	10/01/19	Mulch kit for mowers.	1070261	300.92	WILKINSON SUPPLY
Total 40512:						300.92	
10/03/19	40441	Williams, Dallin	09/30/19	Referee	2071482	78.75	Williams, Dallin
10/03/19	40441	Williams, Dallin	09/30/19	Referee	2071483	56.25	Williams, Dallin
Total 40441:						135.00	
10/17/19	40513	Williams, Dallin	10/10/19	Referee	2071482	22.50	Williams, Dallin
Total 40513:						22.50	
10/24/19	40539	Williams, Dallin	10/01/19	Referee	2071482	37.50	Williams, Dallin
10/24/19	40539	Williams, Dallin	10/01/19	Referee	2071483	48.75	Williams, Dallin
Total 40539:						86.25	
10/03/19	40442	Woodscape of Utah	09/30/19	Playground chips for central park.	1070261	3,600.00	Woodscape of Utah
Total 40442:						3,600.00	
10/24/19	40540	WORKFORCE QA	10/01/19	Drug Test	1058137	50.00	WORKFORCE QA
10/24/19	40540	WORKFORCE QA	10/01/19	Drug Test	1057137	38.00	WORKFORCE QA
10/24/19	40540	WORKFORCE QA	10/01/19	Drug Test	2071137	38.00	WORKFORCE QA

Chk. Date	Check #	Payee	Inv. Date	Description	GL Account	G/L Amt	Merchant Name
Total 40540:						126.00	
10/17/19	40514	Wright, Nathan	10/04/19	Overpayment on Final Bill Acct: 4022005	1021340	125.00	Wright, Nathan
Total 40514:						125.00	
10/17/19	40515	YOUNG AUTOMOTIVE GROUP	10/01/19	Repairs on Mark J. Truck	5140250	645.51	YOUNG AUTOMOTIVE GROUP
Total 40515:						645.51	
Grand Totals:						900,229.33	

Approval Date: _____

Mayor _____

City Recorder: _____

RECOMMENDATION OF APPROVAL

To: South Weber City

From: Dana Q. Shuler, P.E. *Dana Q. Shuler*
City Engineer's Office
Jones & Associates Consulting Engineers

**RE: RECOMMENDATION OF APPROVAL
CHANGE ORDER #1
WESTSIDE RESERVOIR (EXTERIOR) IMPROVEMENTS PROJECT**

Date: November 21, 2019

GENERAL

During project coordination meetings with City staff and Jones & Associates, the new Division of Drinking Water (DDW) water use reporting requirements were discussed. These new requirements require the capability of measuring water use more precisely than in the past. Due to this new requirement, master meters need to be placed at key location in the water system. One of these locations is on the feed line to the Westside Reservoir.

Ormond Construction was previously awarded the contract for the Westside Reservoir Improvements Project in the amount of \$106,569.74. Due to this new metering requirement and Ormond's familiarity with the site and piping, Jones and Associates designed a meter vault and requested change order pricing from Ormond. No meter will be installed at this time. This work will provide the needed vault and piping for the installation of a future meter.

BUDGET

While this change order is under the Westside Reservoir Improvements Project contract, the cost of the work to be performed should be attributed to metering. The 2019-2020 budget contains a project for SCADA and metering. After this change order, the remaining balance for upgrading the SCADA and installing the remaining meter infrastructure is \$215, 383. A summary is as follows:

	Estimate	Actual
2019-2020 Project Budget	\$ 250,000	\$ 250,000
SCADA	\$ 150,000	TBD
Metering	\$ 100,000	TBD
Change Order 1 – Meter Vault		\$ 34,617
Balance*	\$ 0	\$ 215,383

*Does not include engineering or contingencies

APPROVAL RECOMMENDATION

We have reviewed the change order pricing and feel it is reasonable. Due to the lead time on the vault, the contract time will need to be extended for 35 days.

Overall, we recommend that the Council approve Change Order #1 in amount of **\$34,617.48**.

Attachment: Proposed Change Order #1

Change Order No. 1

Project: Westside Reservoir Improvements Project
Owner: South Weber City
Contractor: Ormond Construction

Notice to Proceed: 9/30/2019
Substantial Completion: 12/14/2019
Original Contract Price: \$106,569.74

SUMMARY OF CHANGE ORDER

Description of Change(s): addition of butterfly valve and meter vault for future meter installation

Total Amount of Change: \$34,617.48
Total # of Days: 35

***Revised Contract Price:** \$141,187.22
***Revised Substantial Completion:** 1/18/2020

Attachments: Cost Breakdown, change request proposal from contractor

_____ Recommended for Approval by Engineer	_____ Date
_____ Approved by Director of Public Works	_____ Date
_____ Approved by City Manager	_____ Date
_____ Received by Contractor	_____ Date

*APPROVED CHANGES TO DATE	(additional days)
CO #1: \$ -	-
CO #2: -	-
CO #3: -	-
CO #4: -	-
CO #5: -	-
Total Changes: \$ -	- days



**Cost Breakdown
Change Order No. 1**

No.	Description	Quantity		Unit Price	Total Price
101	Furnish and install meter vault complete with fittings (no meter)	1	LS	\$ 27,561.41	\$ 27,561.41
102	Pothole existing water line	7	HRS	345.00	2,415.00
103	Furnish and install 12" butterfly valve on feed line	1	EA	4,641.07	4,641.07
					-
					-
					-
					-

Total Change in Contract Price: \$ 34,617.48

Additional Time Required

T1	Additional time for lead time for materials and work		35	days

Total Change in Contract Time: 35

ORMOND CONSTRUCTION INC.

P/O Box 598
 Willard, Utah 84340-0598
 Phone 435 723 3531
 Fax 435 723 2910

CLIENT **South Weber City**
Westside Reservoir Improvements Project

* Change Order *

Changes effecting work and/or materials are required to be performed by Ormond Construction Inc.

JOB NAME: Westside reservoir Improvements Project
 ??
 ENGINEER: Jones and Assocaites (Dana Shuler)
 WORK DISCRIPTION: Addition of a meter vault
 PHONE: 435-723-3531
 PRINT DATE: 11/20/2019

The following items will be made part of the original agreement and will be processed accordingly. Payments will be made according to the prices listed and the original agreement amended to include the following:

JOB DESCRIPTION-ORMOND CONSTRUCTION INC. Will complete the following for the cost listed:									
#	ITEM DESCRIPTION	QUANTITY	Unit type	Material	Tax 6.85%	Labor	Overhead 15%	UNIT PRICE	LINE TOTAL
	Meter Vault complete with fittings (no meter as a spool was called out until the city adds the meter at a later date) **LEAD TIME ON METER VAULT IS 3 - 3.5 WEEKS** (Fittings on this cover 12" main to 10" through the meter vault, as per discussion 11-14-19 on site)	1	L.S.	\$ 15,279.85	\$ 1,046.67	\$ 7,639.93	\$ 3,594.97	\$ 27,561.41	\$ 27,561.41
	Potholing/utility investigation for the meter vault	7	Hours		\$ 0.00	\$ 300.00	\$ 45.00	\$ 345.00	\$ 2,415.00
	Cut in valve (in preperation for the meter vault)	1	L.S.	\$ 2,232.77	\$ 152.94	\$ 1,650.00	\$ 605.36	\$ 4,641.07	\$ 4,641.07

Contract time compensation to complete this work: + **35 Days**

Quotes are based on standard 40 hour work weeks excluding overtime compensation.	\$ 34,617.48
TOTAL AGREEMENT PRICE CHANGE:	

WE PROPOSE hereby to furnish material and labor as noted in accordance with these specification for the sum of: **\$ 34,617.48**

thirty-four thousand six hundred seventeen DOLLARS forty eight CENTS

Authorized Signature _____ This proposal may be withdrawn by us if not accepted within ____10____ days.

David L. Ormond

ACCEPTANCE OF PROPOSAL- The prices, specification and conditions are satisfactory and hereby accepted.
 You are authorized to do the work as specified.. Payments will be made as outlined above.

Signature _____ DATE: _____

METER VAULT NOTES:

- A1. PENETRATION WALLS NEED TO BE ADEQUATELY DESIGNED STRUCTURALLY FOR ANTICIPATED THRUST.
- A2. THE PRECAST VAULT MANUFACTURER IS RESPONSIBLE FOR DESIGN RELATED TO TRAFFIC LOADING AND THRUST. VERIFICATION OF PROPER DESIGN MUST BE PROVIDED TO THE CITY BY THE CONTRACTOR OR SUPPLIER AS THE CASE MAY BE.

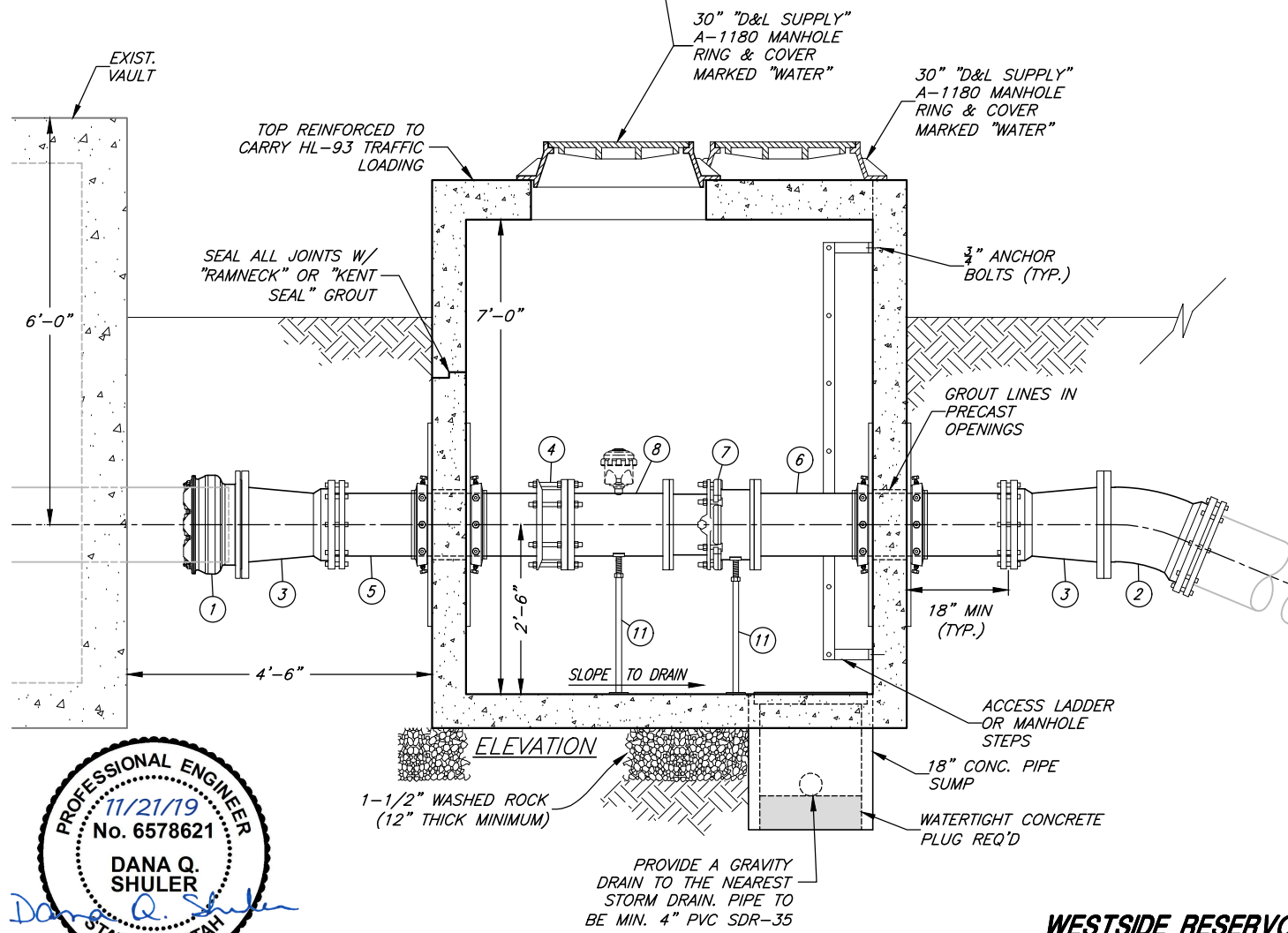
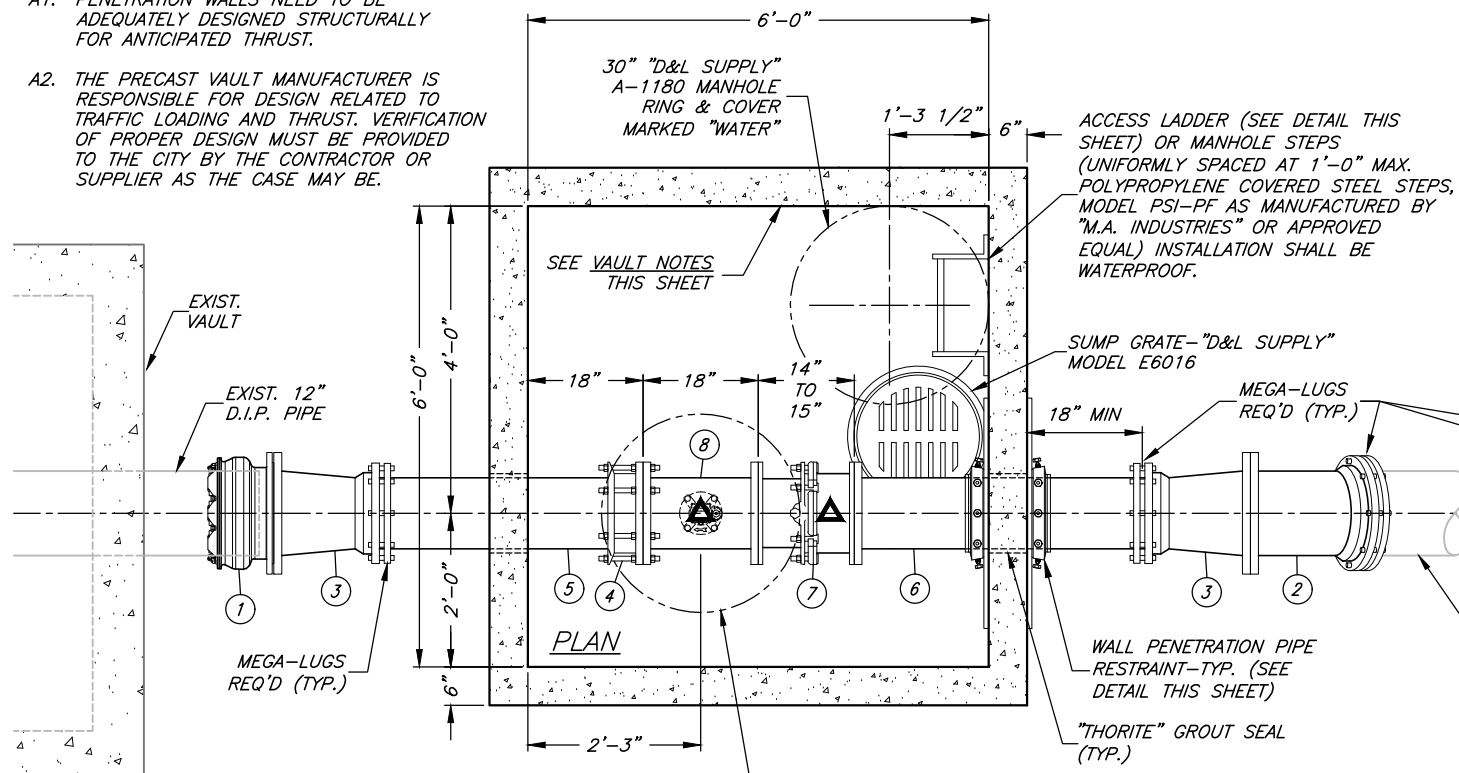

PIPE & FITTING SCHEDULE				
NO.	DESCRIPTION	JOINT TYPE	SIZE	QUANTITY
1	"ROMAC" ALPHA FC RESTRAINED FLANGE COUPLING ADAPTER	FL	12"	1
2	22.5° BEND	FLxMJ	12"	1
3	D.I. REDUCER	FLxMJ	12"x10"	2
4	"ROMAC" FCA501 FLANGE COUPLING ADAPTER OR APPROVED EQUAL	FL	10"	1
5	3'-6" D.I. PIPE SECTION	PE	10"	1
6	4'-0" D.I. NIPPLE PIECE	FLxPE	10"	1
7	"ROMAC" DJ405 DISMANTLING JOINT	FL	10"	1
8	18" D.I. SPOOL PIECE (FUTURE METER LOCATION)	FL	10"	1
9	11.25° BEND	MJxMJ	12"	1
10	BUTTERFLY VALVE W/ BURIED OPERATOR	MJxMJ	12"	1
11	ADJUSTABLE PIPE SUPPORT (2 REQ'D.)			

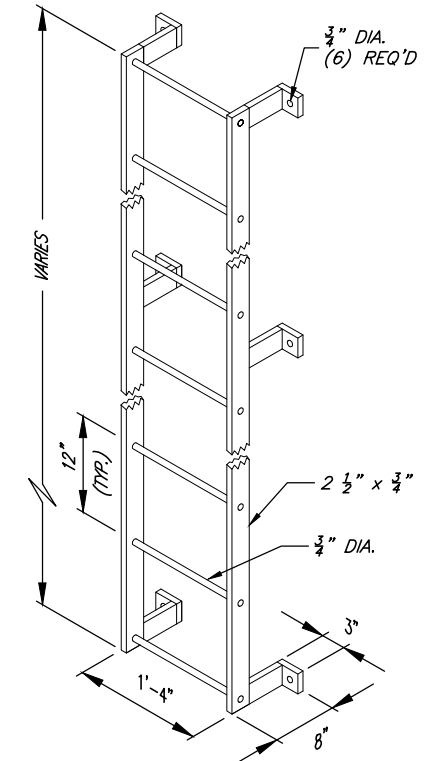

GENERAL NOTES:

- A. "BLUE" BOLTS AND NUTS ARE REQUIRED BY THE CITY.
- B. ALL FITTINGS OUTSIDE OF THE VAULT ARE TO BE DUCTILE IRON MJ WITH THRUST RESTRAINT RETAINER GLANDS ("ROMAC", MJRG, OR APPROVED EQUAL).
- C. ALL FITTINGS SHALL BE AWWA C-110 WITH 125 LB. FLANGES. ALL PIPING SHALL BE DUCTILE IRON PIPE CLASS 350 P.S.I. MIN.

LID MUST SPECIFY "WATER", EAST JORDAN IRON WORKS 6800 VALVE BOX COVER OR APPROVED EQUAL

THE ANCHOR PINS OF THE RESTRAINING GLAND MUST POINT AWAY FROM THE VAULT WALL AS SHOWN.

STEEL PLATE DIMENSIONS:
 10"Ø PIPE OR LESS = 24"x24" PLATE
 12"Ø-18"Ø PIPE = 36"x36" PLATE
 20"Ø PIPE OR GREATER = AS DIRECTED BY CITY ENGINEER

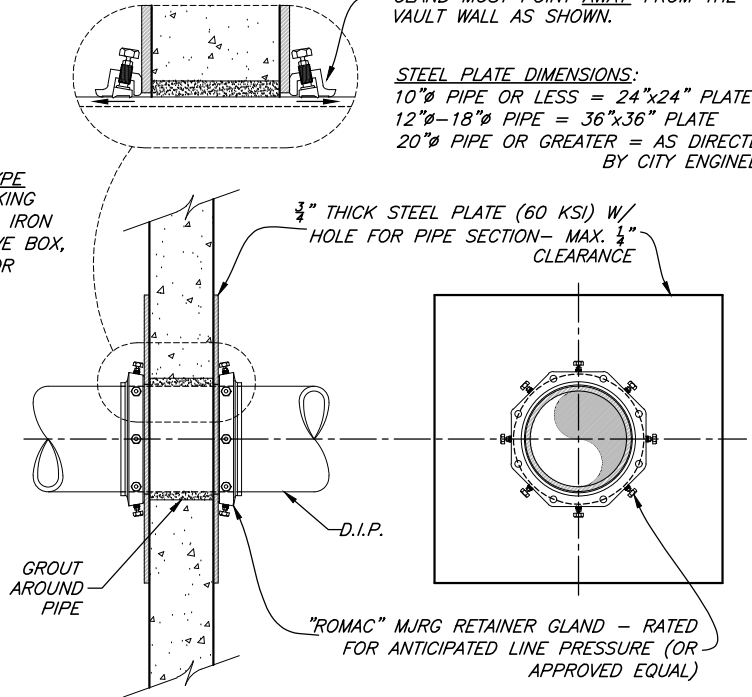

WALL PENETRATION DETAIL
FOR PRECAST VAULT (TYP)

WESTSIDE RESERVOIR METER STATION

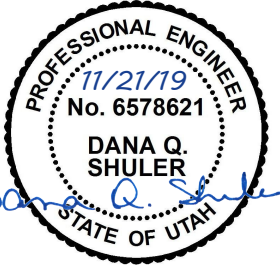

CONSULTING ENGINEERS
JONES & ASSOCIATES
 6080 Fashion Point Drive
 South Ogden, Utah 84403
 (801) 476-9767 www.jonescivil.com

SOUTH WEBER CITY CORPORATION
 DIVISION OF DRINKING WATER COMPLIANCE PROJECT
WESTSIDE RESERVOIR METER STATION

DESIGNED	DRAWN	CHECKED	DATE	APPR.
DQS	BEB	DQS		
SCALE: 24"x36" NONE	SCALE: 11"x17" NONE			
SHEET: 1				
OF 1 SHEETS				

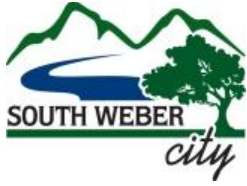

Council Meeting Date: November 26, 2019

Name: Lisa

Agenda Item: Ordinance 19-16 amend high density housing zoning district

Objective: Define what is high density housing for South Weber City

Background: Limiting growth was discussed at the joint meeting of PC and CC on October 22, 2019. Planning Commission was directed to come up with a recommended density less than the current 13 units and a name change which would reflect more accurately what is allowed. Planning Commission met on November 14, 2019 and are recommending 7 units per acre and a rename of the zone to (R-7). They would also like to recommend a moratorium until all zoning codes are reviewed. In keeping consistency in the zone, staff is recommending the name be changed to Residential Multi-Family (R-7)

Summary: Review PC recommendations and amend the high-density zone.

Committee Recommendation: n/a

Planning Commission Recommendation: amend the code

Staff Recommendation: n/a

Attachments: Barry's memo, redline changes, PC minutes, staff emails, Ordinance 19-16

Budget Amendment: n/a

R-H ZONE AMENDMENTS MEMO
By Barry Burton 11.8.19

Purpose:

The reason this proposal is before the Planning Commission is two-fold. One is to give the zone a new name; one that will be more descriptive of what the zone allows and one that is less controversial than “*high density*.” Many cities name their zones based on the minimum lot size allowed; R-1-10 for a zone allowing one dwelling per lot and requiring a minimum of 10,000 sq. ft. etc. Those cities have a lot size-based ordinance. Our ordinance is density based. That is to say, the minimum lot size allowed in any zone is far less than the average lot size must be achieved in order to meet the maximum density. For instance; The minimum lot size in the R-M zone is 9,000 sq. ft. while the maximum density is 2.8 dwellings per acre. In order to meet that density requirement, the average lot size would be closer to 12,000 sq. ft. So, naming the zone R-1-9 would be somewhat confusing.

Another option would be to name the zone based on the maximum density; R-1-2.8 instead of R-M. Or, R-M-13 instead of R-H. In this instance the M stands for multi-family and 13 the density. We could also simplify all the zones to something like R-1, R-2, R-3, where the number simply designates a different residential zone and has nothing to do with the lot size allowed or the type of residential units allowed.

The other purpose in amending the R-H zone is to designate a density that is less than the 13 dwelling units per acre now allowed. We can recommend any number you choose. I will have visual examples of various residential densities for you to consider at the meeting.

SOUTH WEBER CITY PLANNING COMMISSION MEETING Excerpt

DATE OF MEETING: 14 November 2019

TIME COMMENCED: 6:00 p.m.

LOCATION: South Weber City Office at 1600 East South Weber Drive, South Weber, UT

Commissioner Grubb moved to open the public hearing for ORDINANCE 19-16 Amending South Weber City Code Title 10 Chapter 5 Article C: (R-H) Residential High-Density Zone . Commissioner Johnson seconded the motion. Commissioners Grubb, Pitts, Osborne, Walton, and Johnson voted aye. The motion carried.

***** PUBLIC HEARING *****

Public Hearing & Action on ORDINANCE 19-16 Amending South Weber City Code Title 10 Chapter 5 Article C: (R-H) Residential High-Density Zone: City Planner, Barry Burton stated the reason this proposal is before the Planning Commission is two-fold. First, to give the zone a new name that will be more descriptive of what the zone allows and is less controversial than “high density.” He pointed out many cities name their zones based on the minimum lot size allowed; R-1-10 for a zone allowing one dwelling per lot and requiring a minimum of 10,000 sq. ft. etc. Those cities have a lot size-based ordinance. South Weber City’s ordinance is density based. Meaning, the minimum lot size allowed in any zone is far less than the average lot size must be achieved in order to meet the maximum density. For instance, the minimum lot size in the R-M zone is 9,000 sq. ft. while the maximum density is 2.8 dwellings per acre. In order to meet that density requirement, the average lot size would be closer to 12,000 sq. ft. As a result, naming the zone R-1-9 would be somewhat confusing.

Barry explained another option would be to name the zone based on the maximum density; R-1-2.8 instead of RM. Or, R-M-13 instead of R-H. In this instance the M stands for multi-family and 13 the density. We could also simplify all the zones to something like R-1, R-2, R-3, where the number simply designates a different residential zone and has nothing to do with the lot size allowed or the type of residential units allowed. The other purpose in amending the R-H zone is to designate a density that is less than the 13 dwelling units per acre now allowed.

Barry presented visual examples of various residential densities to consider. Cambridge Crossing in South Weber City is 13 units per acre. Briar Ridge in South Ogden is 10.9 units per acre. Freedom Landing Townhomes in South Weber City is 10.6 units per acre. Seasons at the Ridge in South Ogden is 8.7 units per acre with a total of 106 units. Riverside Place in South Weber City is 4.2 units per acre.

Commissioner Osborne asked if there was any public comment.

Julie Losee, 2541 E. 8200 S., voiced 13 units, such as Cambridge Crossing, is a maximum number that the city needs.

Kathy Devino, 2480 E. 8300 S., asked about the density for the Lofts. Barry stated this won't affect the Lofts Subdivision.

Hayley Alberts, 7560 S. 1740 E., suggested the maximum number of units to be 4 to 5 units per acre. She feels South Weber needs to have more open space with a country feel. She feels larger lots can be what this city has to offer individuals looking for that.

Commissioner Grubb moved to close the public hearing for ORDINANCE 19-16 Amending South Weber City Code Title 10 Chapter 5 Article C: (R-H) Residential High-Density Zone. Commissioner Walton seconded the motion. Commissioners Grubb, Pitts, Osborne, Walton, and Johnson voted aye. The motion carried.

***** PUBLIC HEARING CLOSED *****

Barry explained the proposal is to amend the existing R-H Zone by name and density. Commissioner Grubb asked about the effects of renaming, property already zoned, etc. Commissioner Osborne pointed out the R-H Zone allowed Petersen Farms to happen, but also allowed other developments that the city doesn't particularly like. Barry commented the City Council did direct the Planning Commission to look at the number or density. Commissioner Walton pointed out the slide examples are evidence of closed off neighborhoods. He is hoping with the zone there can be more open space reserved. Commissioner Osborne doesn't feel the city has enough large parcels in the city. Commissioner Walton disagreed. Barry explained most of the examples are PUD's. Commissioner Grubb pointed out the minimum lot size goes against minimum unit clustering. Commissioner Walton feels the general plan needs to identify areas the city wants to preserve as open space. Councilman Halverson discussed the bigger picture of this being a whole new philosophy for the city. Commissioner Osborne understands this decision will move us into looking at other areas. Commissioner Grubb believes in open space and feels the R-H Zone is good for multi-family units, but if the city needs to take it from 13 units down, he would suggest a number of 6 to 8 units per acre. He doesn't know if the details of all the high density need to be considered at this point. Commissioner Osborne and Johnson suggest 6 units. Commissioner Pitts and Grubb suggested 8 units. Commissioner Walton suggested 8 to 10 units. Commissioner Walton feels it is more important to define a vision for the zone verses the density.

Commissioner Johnson moved to amend ORDINANCE 19-16 Amending South Weber City Code Title 10 Chapter 5 Article C: (R-H) Residential High-Density Zone to no more than 6 units per acre. Motion died due to lack of a second.

Commissioner Grubb moved to amend ORDINANCE 19-16 Amending South Weber City Code Title 10 Chapter 5 Article C: (R-H) Residential High-Density Zone to no more than 8 units per acre. Commissioner Pitts seconded the motion. Commissioners Grubb, and Pitts voted aye. Commissioner Walton, Osborne, and Johnson voted no. The motion died 3 to 2.

Commissioner Walton voted no because he feels it is more than just defining a number but a bigger picture of the zone. Commissioner Osborne would like to establish this so that it can be

talked about with the general plan. It was stated this is a larger discussion as it relates to the general plan. The Planning Commission suggested a possible moratorium during this period of review.

Commissioner Johnson moved to amend ORDINANCE 19-16 Amending South Weber City Code Title 10 Chapter 5 Article C: (R-H) Residential High-Density Zone to no more 7 than units per acre and title it R-U-7. Motion died due to lack of a second.

Commissioner Grubb moved to recommend to the City Council amend ORDINANCE 19-16 Amending South Weber City Code Title 10 Chapter 5 Article C: (R-H) Residential High-Density Zone to no more 7 than units per acre and title it the R-7 Zone with the recommendation no property be rezoned or developed during the moratorium period. Commissioner Walton seconded the motion. Commissioner Johnson, Pitts, Walton, Grubb, and Osborne voted aye. The motion carried.

DRAFT

From: Douglas Ahlstrom <djahlstrom83@gmail.com>

Sent: Tuesday, November 19, 2019 4:55 PM

To: Kim Guill <kguill@southwebercity.com>; Lisa Smith <lsmith@southwebercity.com>; David J. Larson <dlarson@southwebercity.com>; Barry Burton <bburton@southwebercity.com>; Brandon Jones <brandonj@jonescivil.com>; Mark Larsen <mlarsen@southwebercity.com>

Subject: Re: Temporary Land Use Ordinance - R-H Zone

All, based on David's comment to change the name of R-H, I did a search of the code and found several other sections which referenced R-H and would need to be changed also. Attached is a draft which attempts to make all the changes. I'm struggling with what to name the R-7; it needs a name in addition to the R-7 reference. All zones have a full name in addition to their abbreviation.

Doug



David J. Larson

To: Douglas Ahlstrom; Kim Guill; Lisa Smith; Barry Burton; Brandon Jones; Mark Larsen



Tue 11/19/2019 5:27 PM

Thanks Doug,

What does everyone think about Residential Multi-Family as a name?

David

David J. Larson

City Manager | South Weber City

o 801-479-3177 x207 | f 801-479-0066

dlarson@southwebercity.com



Barry Burton

To: David J. Larson; Douglas Ahlstrom; Kim Guill; Lisa Smith; Brandon Jones; Mark Larsen



Tue 11/19/2019 5:29 F

That is exactly what I would have suggested.

ORDINANCE 19-16

AN ORDINANCE OF THE SOUTH WEBER CITY COUNCIL AMENDING THE RESIDENTIAL HIGH-DENSITY (R-H) ZONING DISTRICT TO RESIDENTIAL MULTI-FAMILY (R-7)

WHEREAS, the Residential High Density (R-H) zoning district exists to provide for neighborhoods of varying degrees of density, to promote an intensively developed residential environment suitable primarily for adult living, and to provide alternate forms of residential living ranging from single-family to twelve-family dwellings and necessary public services; and

WHEREAS, the Planning Commission held a public hearing on November 14, 2019 on the issue of amending the R-H zoning district to reduce the density from 13 units per acre to seven, and to change the name to Residential Multi-Family (R-7) and has recommended to the Council that the amendment be made; and

WHEREAS, the Council finds and determines that amending the R-H Zoning District to limit its density to seven units per acre is in the best interest of the City and will provide for the health and welfare and good order of its citizens;

NOW, THEREFORE, BE IT ORDAINED by the City Council of South Weber City, State of Utah:

Section 1. Title Amended: TITLE 10 CHAPTER 5: ZONING DISTRICTS ARTICLE C. RESIDENTIAL HIGH-DENSITY ZONE (R-H) shall now be TITLE 10 CHAPTER 5: ZONING DISTRICTS ARTICLE C. RESIDENTIAL MULTI-FAMILY SEVEN ZONE (R-7)

Section 2. Section Amended: Section 10-5C-5 of the Residential High-Density Zone (R-H) of the South Weber City Code is hereby amended to read:

10-5C-5: BUILDING LOT REQUIREMENTS:

- A. Density: There shall be no more than seven dwelling units per acre contained within the boundaries of each phase of every development; except when previously completed phases of the same development have sufficiently low density so that the average is still seven dwelling units per acre or less.
- B. Lot Area:
 - 1. There shall be a minimum of twelve thousand (12,000) square feet in each lot on which a single-family or two-family dwelling is built.
 - 2. There is no minimum lot area for other dwelling types, but the density requirement listed above must be adhered to in all cases.
- C. Lot Width: Each lot shall have a minimum width of one hundred feet (100').

Section 3: Section Amended: Section 10-5C-10: SPECIAL CONDITIONS of the Residential High-Density Zone (R-H) of the South Weber City Code is hereby amended to read:

10-5C-10: SPECIAL CONDITIONS:

Due to the higher residential densities permitted by this article, the following conditions are required in order to assure a quality livable environment:

- A. Minimum and Maximum Area: The minimum area that may be zoned R-7 shall be two (2) acres and the maximum area which may be zoned R-7 in any zone district shall be nine point five (9.5) acres.
- B. Open Space: Multi-family dwellings shall provide usable functional open space for outdoor leisure in the following amounts:
 - 1. Eight hundred (800) square feet per unit for one- and two-family dwellings;
 - 2. Six hundred (600) square feet per unit for three- and four-family dwellings; and
 - 3. An additional four hundred (400) square feet per dwelling unit for each additional unit over four (4).
- C. Outdoor Storage Space: Three-family, four-family and multi-family dwellings shall provide enclosed outside storage space of at least thirty (30) square feet for each dwelling unit. (Ord 2000-9, 7-11-2000)

Section 4: Section amended: Section 10-5C-11: LANDSCAPING REQUIREMENTS of the Residential High-Density Zone (R-H) of the South Weber City Code is hereby amended to read:

Section 10-5C-11: LANDSCAPING REQUIRMENTS:

- A. General Landscaping: At least fifteen percent (15%) of the total site shall be thoroughly landscaped, including an irrigation system to maintain such landscaping. Landscaping shall meet the requirements of chapter 15 of this title. For use of exceptional design and materials, as determined by the Planning Commission, the landscaping may be reduced to ten percent (10%) of the total site.
- B. Fencing: A six-foot (6') tall solid screening fence shall be required between the Residential Multi-Family (R-7) Zone and all lower density residential zones. (Ord 18-05, 8-14-2018)

Section 5: Section amended: Section 10-5C-115 of the South Weber City Code is hereby amended to read:

10-15-2: GENERAL REQUIREMENTS:

- A. Required: All land approved for development in the city shall be constructed as required by city ordinances and the planning commission or city council. In order to control the potential for adverse conditions resulting from dust, mud and erosion, land remaining on developed sites that is not covered with structures or impervious surfaces such as

ORD 19- 16 R-H Zone

driveways, walks, courts, landscape features (sculptures, boulders, etc.), shall be landscaped in accordance with this chapter and when applicable irrigated with an appropriate system to maintain plants in a healthy, growing condition, compatible with the general neighborhood appearance.

B. Residential Front, Side, And Back Yard Areas: Landscaping shall be installed in all residential front yards, side yards, and back yards in residential low-moderate (R-LM), residential moderate (R-M), and Residential Multi-Family (R-7) zones. Front and side yard landscaping shall be completed within eighteen (18) months of occupancy. Back yards shall be landscaped within twenty-four (24) months of occupancy. Landscaping of a residential site shall include an irrigation system sufficient to maintain the health and beauty of the landscaping. Residents who fail to abide by these landscaping regulations are subject to penalties as set forth in section [10-15-8](#) of this chapter.

Section 5. General Repealer. Ordinances in conflict with this ordinance are hereby repealed to the extent of such conflict.

Section 6. Effective Date. The City Council of South Weber City, State of Utah, has determined that the public health, safety and welfare requires that this ordinance take effect immediately. Therefore, this ordinance shall become effective immediately upon passage and publication as required by law.

PASSED AND ADOPTED by the City Council of South Weber, Davis County, on the 26th day of November 2019.

MAYOR: Jo Sjoblom

ATTEST: City Recorder, Lisa Smith

Roll call vote is as follows:		
Council Member Halverson	FOR	AGAINST
Council Member Hyer	FOR	AGAINST
Council Member Petty	FOR	AGAINST
Council Member Taylor	FOR	AGAINST
Council Member Winsor	FOR	AGAINST

CERTIFICATE OF POSTING

I hereby certify that Ordinance 19-16 was passed and adopted the 26th day of November 2019 and that complete copies of the ordinance were posted in the following locations within the City this 27th day of November 2019.

1. South Weber Elementary, 1285 E. Lester Drive
2. South Weber Family Activity Center, 1181 E. Lester Drive
3. South Weber City Building, 1600 E. South Weber Drive

Lisa Smith, City Recorder

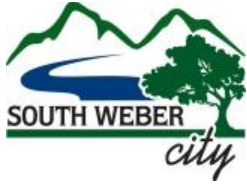

Council Meeting Date: November 26, 2019

Name: Lisa

Agenda Item: Ordinance 19-17 amending condition use permit requirements

Objective: Amend conditional use permit code to include a timeline for reapplication after revocation

Background: The recent concerns with a short-term rental conditional use permit (CUP) has necessitated a look at the CUP revocation process. The City wants to address any permittee re-applying for the same purpose which was revoked without having adequate time to address the problems which caused the revocation in the first place. On Nov 20, 2019 Planning Commission reviewed the proposed ordinance and recommends approval. They would like the Council to consider a clause to allow discretion in the timeline if a property is sold.

Summary: Ordinance 19-17 amends City Code 10-7-2 to require 2 years following a CUP revocation prior to allowing a CUP application at the same address, for the same applicant, or for the same purpose.

Committee Recommendation: n/a

Planning Commission Recommendation: Approve ORD 19-17

Staff Recommendation: Approve ORD 19-17

Attachments: Code redline, PC minutes, Ordinance 19-17

Budget Amendment: n/a

10-7-2: CONDITIONAL USE PERMIT REQUIRED; REVOCATION:

A. A conditional use permit shall be required for all uses listed as conditional ~~uses~~ in the ~~zoneland use~~ regulations.

B. A conditional use permit may be revoked by the city council after a review and recommendation by the planning commission, upon failure to comply with the conditions imposed with the original approval of the permit.

C. An application for a conditional use permit is prohibited for two years following the revocation of a conditional use permit at the same address, for the same applicant, or for the same purpose.

SOUTH WEBER CITY PLANNING COMMISSION SPECIAL MEETING

DATE OF MEETING: 20 November 2019

TIME COMMENCED: 6:00 p.m.

LOCATION: South Weber City Office at 1600 East South Weber Drive, South Weber, UT

PRESENT: COMMISSIONERS:

Tim Grubb (arrived 6:03)
Debi Pitts
Rob Osborne
Wes Johnson
Taylor Walton

DEVELOPMENT COORDINATOR: Kimberli Guill

Transcriber: Minutes transcribed by Michelle Clark

ATTENDEES: Hayley Alberts, Paul Sturm, Sandra Layland, Lara Wright, and Tom Wright.

PLEDGE OF ALLEGIANCE: Commissioner Johnson

Commissioner Walton moved to open the public hearing for Ordinance 19-17: Amending City Code 10-7-2 Regarding Conditional Use Permit Requirements. Commissioner Johnson seconded the motion. Commissioners Grubb, Pitts, Osborne, Walton, and Johnson voted aye. The motion carried.

***** PUBLIC HEARING *****

Public Hearing & Action on Ordinance 19-17: Amending City Code 10-7-2 Regarding Conditional Use Permit Requirements: The Planning Commission has considered a proposal to prohibit applications for conditional use permits for two years following the revocation of a conditional use permit at the same address, for the same applicant, or for the same purpose.

Commissioner Osborne asked if there was any public comment. There was none.

Commissioner Grubb queried if the City Council will be flexible with the two year revocation of the conditional use permit. Development Coordinator, Kim Guill stated she will ask the City Manager or City Attorney. Discussion took place regarding what happens to the conditional use permit if a property is sold. Commissioner Grubb pointed out the realtor is required by law to disclose this information.

Commissioner Taylor moved to close the public hearing for Ordinance 19-17: Amending City Code 10-7-2 Regarding Conditional Use Permit Requirements. Commissioner Pitts

Johnson seconded the motion. Commissioners Grubb, Pitts, Osborne, Walton, and Johnson voted aye. The motion carried.

***** PUBLIC HEARING CLOSED *****

Commissioner Grubb moved to approve Ordinance 19-17: Amending City Code 10-7-2 Regarding Conditional Use Permit Requirements. Commissioner Pitts seconded the motion. Commissioners Grubb, Pitts, Osborne, Walton, and Johnson voted aye. The motion carried.

PLANNING COMMISSION ITEMS: (None)

ADJOURNED: Commissioner Grubb moved to adjourn the Planning Commission meeting at 6:12 p.m. Commissioner Walton seconded the motion. Commissioners Grubb, Pitts, Osborne, Walton, and Johnson voted aye. The motion carried.

APPROVED: _____ Date

Chairperson: Rob Osborne

Transcriber: Michelle Clark

Attest: Development Coordinator: Kimberli Guill

ORDINANCE 19-17

AN ORDINANCE OF THE SOUTH WEBER CITY COUNCIL AMENDING CITY CODE 10-7-2 REGARDING CONDITIONAL USE PERMIT REQUIREMENTS

WHEREAS, Utah Code Ann. 10-9a-507(1)(a) provides that a municipality may adopt a land use ordinance that includes conditional uses and provisions for conditional uses that require compliance with standards set forth in an applicable ordinance; and

WHEREAS, the Planning Commission has considered a proposal to prohibit applications for conditional use permits for two years following the revocation of a conditional use permit at the same address, for the same applicant, or for the same purpose, and has recommended to the Council that the same be adopted; and

WHEREAS, the Council finds it is in the best interest of the City to amend City Code 10-7-2 to include such a provision, and to make additional technical amendments to such section;

NOW, THEREFORE, BE IT ORDAINED by the City Council of South Weber City, State of Utah:

Section 1. Section Amended. South Weber City Code Section 10-7-2 is hereby amended to read:

10-7-2: CONDITIONAL USE PERMIT REQUIRED; REVOCATION:

- A. A conditional use permit shall be required for all uses listed as conditional in the land use regulations.
- B. A conditional use permit may be revoked by the City Council after a review and recommendation by the Planning Commission, upon failure to comply with the conditions imposed with the original approval of the permit.
- C. An application for a conditional use permit is prohibited for two years following the revocation of a conditional use permit at the same address, for the same applicant, or for the same purpose.

Section 2. General Repealer. Ordinances in conflict with this ordinance are hereby repealed to the extent of such conflict.

Section 3. Effective Date. The City Council of South Weber City, State of Utah, has determined that the public health, safety and welfare requires that this ordinance take effect immediately. Therefore, this ordinance shall become effective immediately upon passage and publication as required by law.

PASSED AND ADOPTED by the City Council of South Weber, Davis County, on the 26th day of November 2019.

MAYOR: Jo Sjoblom

ATTEST: City Recorder, Lisa Smith

Roll call vote is as follows:		
Council Member Halverson	FOR	AGAINST
Council Member Hyer	FOR	AGAINST
Council Member Petty	FOR	AGAINST
Council Member Taylor	FOR	AGAINST
Council Member Winsor	FOR	AGAINST

CERTIFICATE OF POSTING

I hereby certify that Ordinance 19-17 was passed and adopted the 26th day of November 2019 and that complete copies of the ordinance were posted in the following locations within the City this 27th day of November 2019.

1. South Weber Elementary, 1285 E. Lester Drive
2. South Weber Family Activity Center, 1181 E. Lester Drive
3. South Weber City Building, 1600 E. South Weber Drive

Lisa Smith, City Recorder

From: [Chris Tremea](#)
To: [Lisa Smith](#)
Subject: Summary Template.dotx
Date: Monday, November 18, 2019 10:12:28 AM
Attachments: [Summary Template.dotx](#)
[ATT00001.txt](#)

Background

The Cobblestone resort is located in a large single family dwelling located at 1923 E Canyon Drive. This short term rental is owned and operated by Wanai Miller and her son Dustin Shiotzti.

The City has been heavily involved in this occupancy due to the amount of complaints from local residents. The Code Enforcement Officer was heavily involved in assisting and educating the operators of the business to understand and abide by the local codes and ordinances of the city.

When communication broke down and the education was not working as effectively as it was hoped for enforcement of the code became necessary. I am still working to obtain all the nuisance complaints from the local citizens as they come in and presented to me.

Chris Tremea

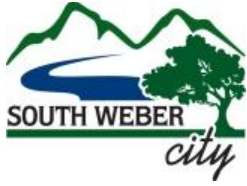

Council Meeting Date: November 26, 2019

Name: David

Agenda Item: Consider Revocation: Conditional Use Permit #STR 19-03 at 1923 E Canyon Drive

Objective: Revoke CUP #STR 19-03

Background: The Planning Commission held a Public Hearing on October 23, 2019, reviewing the incidents that have taken place at the short-term rental named Cobblestone Resort, located at 1923 E Canyon Drive. They recommend a revocation of CUP #STR 19-03.

Summary: Following numerous incidents related to the property known as Cobblestone Resort, the Council may revoke the conditional use permit to operate a short-term rental on the property.

Committee Recommendation: n/a

Planning Commission Recommendation: Revoke CUP

Staff Recommendation: n/a

Attachments: CUP Application, CUP #STR 19-03, Strike 1, Strike 2, Strike 3, PC Minutes 10.23.19

Budget Amendment: n/a

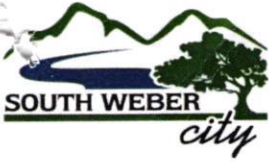

APPLICATION PROCESS: Please submit all requested items and answer all questions as completely as possible, omissions may delay processing. If there are any questions, contact the City Office at (801) 479-3177 4:30

Wm

Application with fees (fees listed on Conditional Use Application) (cash or check)

Wm

Copy of the recorded plat showing subject property (clearly marked) and all properties within 300 feet (front, back and sides). This information is available at the Davis County Recorder's Office.

Wm

One set of labels with names and mailing addresses of all property owners within 300 feet of the outer boundary of subject property. Including "Or current resident" is recommended. Names are available at Davis County Assessor's Office. Allow 2 days for processing. The Assessor can also provide the labels for an additional fee.

Wm

A list of the above names and addresses.

Wm

Register Business with the State of Utah (provide # on Business License Application)

Wm

Obtain a Utah State Sales Tax Id Number (provide # on Business License Application)

Wm

Completed South Weber City Business License Application (License will be issued after Conditional Use Permit is granted).

Wm

Agree to ensure that no more than one short-term or vacation rental agreement per Dwelling unit is in use at any one time.

(19)

Office Use Only

CU: _____

Max Occupancy: _____ Approved or Denied (circle one) Date: _____

Fire Inspection Completion Date: _____ Approved or Denied (circle one)

[Conditional Use Fee: \$200] [Business License Fee: \$50] [Fire Inspection Fee: \$40]

Total Fee: \$290 Receipt# 10.026073 Date Paid: 6/17/2019

Short Term Rental

Conditional Use Application

Property Owner: Won Ae Mui / Shiozaki ^{Dustin} Owner Email: Woloken@yahoo.com

Full Mailing Address: 13606 S. 2200 W. Riverton, VT 84065

Daytime Phone: 801-706-1225 Nighttime Phone: 801-706-1225

Property Address: 1923 E. Canyon Dr. S. Weber, VT. 84405

Is Property to be Owner Occupied: NO {If "NO" fill out Local Responsible Party Lines Below}

Local Responsible Party: Won Ae Mui Local Party Email: Woloken@yahoo.com

Local Responsible Party Mailing Address: 13606 S. 2200 W. Riverton, VT 84065

Local Party Daytime Phone: 801-706-1225 Nighttime Phone: 801-706-1225

Proposed Use: Short Term Rental Parcel Number(s): 13-184-0030

Total Acres: 1.74 Current Zone: Residential Surrounding Land Uses: None

Business Name (if applicable): Cobblestone Resort

Anticipated # of Employees: 4 Anticipated # of Customers (Daily): it varies daily

Hours of Operation: 40 hrs / wk Days of Operation: 7 days / wk

of Bedrooms: 4 # of Parking Stalls: 8 # of Smoke Detectors: 4

of Carbon Monoxide Detectors: 1 # of Fire Extinguishers: 1

APPLICANT'S AFFIDAVIT

State of Utah)
County of _____)

I, Won Ae Mier, the sole owner or Authorized Agent of the Owner of the property involved in this application, swear the statements and answers contained herein, in the attached plans, and other exhibits, and that the statements and information above referred to are in all respects true and correct to the best of my knowledge and belief. By signing below, I am agreeing to abide by ALL terms and conditions set forth in: **South Weber City Code Chapter 10.18 Enacting Regulations Pertaining to Short-Term or Vacation Rentals.**

I do also hereby give permission to South Weber City to place a city "public notice" sign on the property contained in this application for public notification of the conditional use application and to enter the property to conduct any inspections related to this application.

Date 5/24/2019 Owner or Agent's Signature Won Ae Mier

Subscribed and sworn to before me on May 24, 2019

State of Utah
County of Davis
On this 24 day of May, 2019, Won Ae Mier personally appeared before me,
 who is personally known to me,
 whose identity I verified on the basis of Utah Driver License
_____ whose identity I verified on the oath/affirmation of _____ a credible witness.
to be the signer of the foregoing document, and he/she acknowledged that he/she signed it.
Suzanne D. Wright Notary Public
My Commission Expires: 10-16-2019

Notary Public Suzanne D. Wright

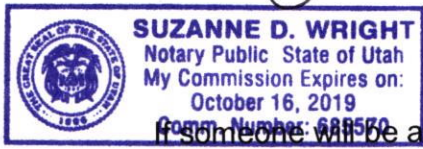

If someone will be acting on behalf of the owner, fill out the information below.

AGENT AUTHORIZATION

State of Utah)
County of _____)

I, _____, the sole owner(s) of the real property in this application hereby appoint _____ as my agent with regard to this application and authorize said agent to appear on my behalf before any city commission, board or council considering this application.

Date _____ Owner's Signature _____

Subscribed and sworn to before me on _____

Notary Public _____

For Office Use Only

Application/License #: _____
Approved By: _____ Date: _____
License Fee: \$ _____ Receipt #: _____
Fire Inspection Fee: \$ _____ Receipt #: _____
Initial Fire Inspection: _____ Next: Annually Every 3 years

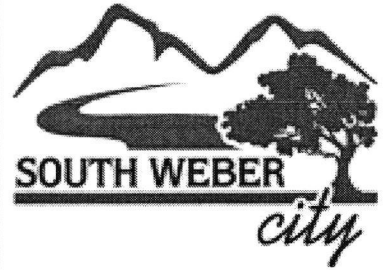

BUSINESS LICENSE APPLICATION

Type of Business: (Check One)
 Home Occupation with Onsite Patrons/Employees
 Home Occupation without Onsite Patrons/Employees
 Construction
 Group Home
 Commercial
 Mobile
 Temporary From: _____ To: _____
(Not to exceed 90 days)
 Occupation Not Expressly Identified

Alcoholic Beverage License Type: NA

Applicant

Name: Won Ae L. Mier
Mailing Address: 13606 S. 2200 W.
City/State/Zip: Riverton, UT 84065
Phone: 801-706-1225
Email: woloken@yahoo.com

Best Way/Preferred Method of Contact:

Email Phone Fax Mail

Business

Name: Cobblestone Resort, LLC
Brief Description: We will be operating Airbnb out of our home
Owner's Name: Won Ae L. Mier
State License #: 83-1811200
Entity #: 10975492-0163
State Sales & Use Tax #: 20-8421151
Federal ID#: 529-92-9428
Address: 1923 E. Canyon Dr.
City/State/Zip: S. Weber, UT 84405
Parcel #: 13-184-0030 Zone: _____

Phone: 801-706-1225 Fax: _____
Email: woloken@yahoo.com
Emergency Contact: Dustin Shozaki ⁴³⁵⁻⁸²⁸⁻ 2292
Name Phone

Home Occupations Only:

Does this business require a Conditional Use Permit? Yes No If yes, date of approval: _____

Square Footage of Business: 3,000 Total Square Footage of Residence (if applicable): 3,000
home occupation cannot exceed 15% of residence, storage cannot exceed 50% of business

Will this business include a part-time employee (other than applicant)? Yes No

- If yes, is the employee a bona fide resident of the dwelling? Yes No
 - If no, Planning Commission approval required

➤ Number of hours part-time employee will work: 10 hrs/week

Will a sign be used to advertise business? Yes No
(If yes, attach sketch showing design, size, and location of sign, see Ordinance 10-9-4B)

To be completed and signed by Applicant

APPLICANT AFFIDAVIT

State of Utah)
County of SLC)

I (We) Won Ae Mer, being duly sworn, depose and say I (we) am (are) the sole owner(s)/
Property Owner(s) or Agent
agent of the owner(s), of the property involved in this application, to wit, 1923 E. Canyon Dr,
Property Address S. Weber 84405

South Weber, Utah, and that the statements and answers contained herein, in the attached plans, and other exhibits, thoroughly and to the best of my ability, present the argument in behalf of the application. Also, all statements and information are in all respects true and correct, to the best of my knowledge and belief; and in consideration of obtaining this permit, I have read and agree to all conditions set forth in Title 3, Business & License Regulations, of the South Weber City Code.

Dated this 24th day of May, 2019.

Signed: Won Ae Mer Applicant (Property Owner or Agent) _____ Applicant (Property Owner or Agent)

Subscribed and Sworn before me this 24 day of May, 2019.



Notary Public: Megan J. Millet

To be completed and signed by Property Owner if not Applicant

AGENT AUTHORIZATION

State of Utah)
County of _____)

I (We) _____, the sole owner(s) of the real property located at
Property Owner(s)
_____, South Weber City, Utah, do hereby appoint _____,
Property Address

as my (our) agent to represent me (us) with regard to this application affecting the above described real property, and to appear on my (our) behalf before any city boards considering this application.

Dated this _____ day of _____, _____.

Signed: _____ Property Owner _____ Property Owner

Subscribed and Sworn before me this _____ day of _____, 20____.

Notary Public: _____

NOTE: If a secondary agent authorization is needed, such as an apartment manager, two agent authorizations will be required. You may copy this page for this purpose or obtain another form at the City office.

Return to South Weber City with Application

ASSESSOR'S USE ONLY

DIST _____ ACCOUNT # _____ PARCEL _____ AREA _____

DAVIS COUNTY ASSESSOR
NEW BUSINESS INFORMATION RECORD
PHONE (801)451-3249 FAX (801)451-3134

BUSINESS NAME: Cobblestone Resort, LLC

MAILING ADDRESS 1923 E. Canyon Dr,
S. Weber, UT 84405

BUSINESS LOCATION: 1923 E. Canyon Dr,

BUSINESS LICENSE #: 83-181200 NATURE OF BUSINESS: Hospitality

FEDERAL TAX ID # (NO SOCIAL SECURITY #): _____

PHONE NUMBER: 801-706-1225 DATE OPENED: 10/2018

TYPE OF BUSINESS (CHECK ONE):

_____ SOLE PROP. _____ PARTNERSHIP _____ CORPORATION X L.L.C

STATE THE VALUE OF PERSONAL PROPERTY USED IN YOUR BUSINESS: \$ 550,000
(DO NOT INCLUDE INVENTORY FOR SALE)

OWNER OR REGISTERED AGENT: WomAe Mier, Dustin Shirozaki

OWNER/AGENT ADDRESS: 13606 S. 2200 W,
Riverton, UT 84065

STAMP

PLEASE RETURN THIS FORM WITHIN TEN DAYS TO:
DAVIS COUNTY ASSESSOR
PERSONAL PROPERTY DIVISION
P.O. BOX 618
FARMINGTON, UT 84025-0618

184

PLEASANT VALLEY PARK SUBDIVISION PLAT B
 LOCATED IN THE SW 1/4 SECTION 26, T5N, R1W, S1B and M.
 SOUTH WEBER CITY, DAVIS COUNTY, UTAH
 APRIL 1997

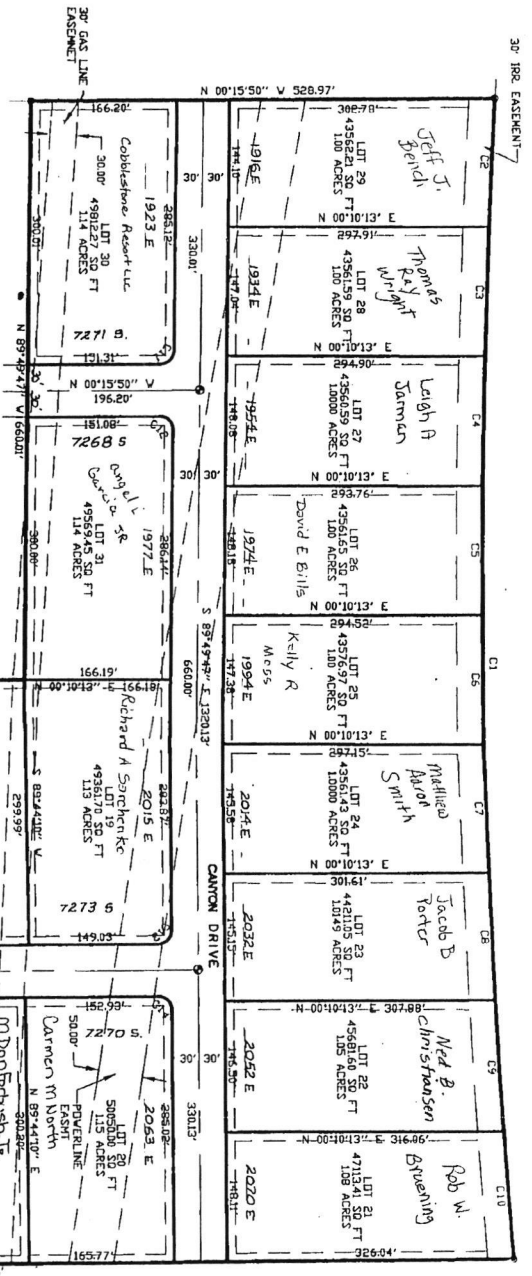

•CLARKE DATA•

NUMBER	DELTA	CHORD DIR.	RAD.	LENGTH	CHORD
C1	06°22'47"	N 89°09'37" E	11559.16	142.47	1320.01
C2	00°43'34"	S 87°55'46" E	11559.16	142.47	146.47
C3	00°43'34"	S 87°55'46" E	11559.16	142.47	147.08
C4	00°44'03"	S 89°23'19" E	11558.55	148.09	148.08
C5	00°44'03"	N 89°23'19" E	11558.55	148.18	148.18
C6	00°43'34"	N 89°09'37" E	11559.16	142.40	147.00
C7	00°43'34"	N 89°09'37" E	11559.16	142.40	146.29
C8	00°43'34"	N 87°41'00" E	11567.45	145.29	145.29
C9	00°43'38"	N 86°58'28" E	11559.16	146.72	146.72
C10	00°43'22"	N 86°14'52" E	11559.16	145.84	145.84
C11	89°33'57"	S 45°02'49" E	15.00	23.45	21.13
C12	90°26'03"	N 44°57'11" E	15.00	23.45	21.29
C13	89°33'57"	S 45°02'49" E	15.00	23.45	21.13
C14	90°26'03"	N 44°57'11" E	15.00	23.45	21.29
C15	90°26'03"	N 44°57'11" E	15.00	23.45	21.29
C16	89°33'57"	S 45°02'49" E	15.00	23.45	21.13

NOTES:
 -PUBLIC UTILITY EASEMENTS ARE SHOWN BY DASHED LINES.
 -FRONT LOT LINES--100'
 -REAR LOT LINES--100'
 -LOT 20 IS LABELED WITH AN R WHICH INDICATES NO BUILDING UPON THIS LOT UNTIL FUTURE EASEMENT IS ABANDONED.

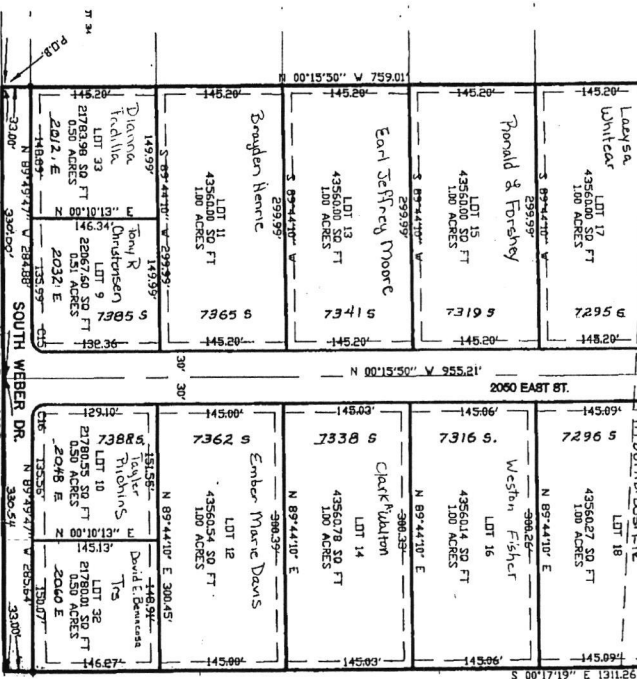
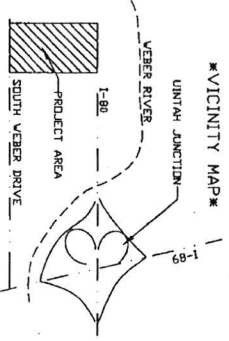

LANDMARK SURVEYING
 A COMPLETE SURVEYING SERVICE
 2485 GRAND AVENUE SUITE 318 CORNHILL, UTAH 84401
 PHONE 827-4014

0=SET 5/8" X 24" LENGTH REBAR
 W/CAP STAMPED 167594
 6=SET MONUMENT

SW 1/4 SECTION 26 T5N R1W
 SALT LAKE MERIDIAN
 DAVIS COUNTY UTAH

SUBDIVISION: PLEASANT VALLEY PARK PLAT B
 CITY: SOUTH WEBER LOTS: 9-33

SCALE:
 1" = 1100'

PREFIX
 13-184
 LAST #

R 8-28-97

parceltaxi	ownername	mailadd1	mailcity
133430002	RAY CREEK LLC	11148 ZEALAND AVE N	CHAMPLI
133430017	RAY CREEK LLC	11148 ZEALAND AVE N	CHAMPLI
130120075	B & N PROPERTIES LLC	825 EAST HWY 193	LAYTON
130120076	PETERSEN, MATTHEW R - TRUSTEE	1820 EAST SOUTH WEBER DR	SOUTH W
131790001	SIMPSON, CLAY R & TRUDI B	7343 SOUTH 1950 EAST	SOUTH W
131790002	GLENDENING, WILLIAM E & SHERRY	7321 SOUTH 1950 EAST	SOUTH W
131790003	HADLOCK, M BRYAN & BRIDGETTE I	7297 SOUTH 1950 EAST	SOUTH W
131790006	LUK, ALAN W L AND CHAN, MIRANDA MANCHEE	7340 SOUTH 1950 EAST	SOUTH W
131790007	HANSEN, CHRISTIAN M & MARY K	7318 SOUTH 1950 EAST	SOUTH W
131790008	LAYLAND, TRENT S & SANDRA J	7294 SOUTH 1950 EAST	SOUTH W
131840025	MOSS, KELLY R	1994 EAST CANYON DR	SOUTH W
131840026	BILLS, DAVID E & CRICKET M	1974 EAST CANYON DR	SOUTH W
131840027	JARMAN, LEIGH A & LINCOLN P	1954 EAST CANYON DRIVE	SOUTH W
131840028	WRIGHT, THOMAS RAY & LARA LYNN	1934 EAST CANYON DRIVE	SOUTH W
131840029	BENCH, JEFF J & HILARY H	1916 EAST CANYON DRIVE	SOUTH W
131840030	COBBLESTONE RESORT LLC	1923 EAST CANYON DR	SOUTH W
131840031	GARCIA, ANGEL L JR	5374 WEST 5100 SOUTH	HOOPER
133430016	RAY CREEK LLC	11148 ZEALAND AVE N	CHAMPLI
133430001	RAY CREEK LLC	11148 ZEALAND AVE N	CHAMPLI
133430003	MCCLUNE, MARLEY ANN AND BRADSHAW, TAYLOR WAYNE	697 WEST 2400 NORTH	LAYTON
133430004	RAY CREEK LLC	11148 ZEALAND AVE N	CHAMPLI
133430005	RAY CREEK LLC	11148 ZEALAND AVE N	CHAMPLI
133430006	RAY CREEK LLC	11148 ZEALAND AVE N	CHAMPLI
133430007	RAY CREEK LLC	11148 ZEALAND AVE N	CHAMPLI
133430008	RAY CREEK LLC	11148 ZEALAND AVE N	CHAMPLI
133430009	BRUDERER, JOSEPH & MORGAN M	1649 NORTH 2400 WEST	CLINTON
133430010	RAY CREEK LLC	11148 ZEALAND AVE N	CHAMPLI
133430011	RAY CREEK LLC	11148 ZEALAND AVE N	CHAMPLI
133430012	RAY CREEK LLC	11148 ZEALAND AVE N	CHAMPLI
133430013	RAY CREEK LLC	11148 ZEALAND AVE N	CHAMPLI
133430014	RAY CREEK LLC	11148 ZEALAND AVE N	CHAMPLI
133430015	RAY CREEK LLC	11148 ZEALAND AVE N	CHAMPLI

mailstate mailzipcod

MN 55316
MN 55316
UT 84041
R UT 84405
R UT 84405
R UT 84405
R UT 84405
R UT 84405
R UT 84405
R UT 84405
R UT 84405
R UT 84405
R UT 84405
R UT 84405
R UT 84405
R UT 84405
UT 84315
MN 55316
MN 55316
UT 84041
MN 55316
MN 55316
MN 55316
MN 55316
MN 55316
UT 84015
MN 55316
MN 55316
MN 55316
MN 55316
MN 55316
MN 55316

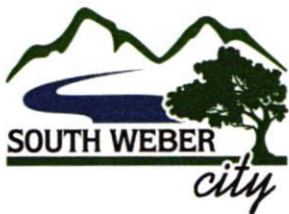

1600 E. South Weber Drive
South Weber, UT 84405

www.southwebercity.com

801-479-3177
FAX 801-479-0066

Short Term Rental Conditional Use Permit # STR 19-03

Applicant: Cobblestone Resort

Proposed Use: SHORT TERM RENTAL

Address: 1923 E Canyon Drive South Weber UT, 84405

Along with compliance to all applicable state and city code, the conditional use for the above applicant at the property listed and the use proposed has been approved by the **Planning Commission on (August 8, 2019)** with the following conditions:

- 1- Comply with ALL portions of ORD 19-12: Regulations pertaining to Short-Term or Vacation Rentals.
- 2- ALL Tenants MUST use off street Parking
- 3- Maximum of 18 Occupants
- 4- Conditional Use Permit Review Yearly

Note: City Staff shall have the right to inspect and enforce conditions. Any non-compliance will be subject to cancellation of this permit. Any requests for change must be made in writing and approved by the Planning Commission in a public meeting.

Applicant: Wonae Mier Owner STR

Planning Commission: Rob Osborne, Chair 

Fire Department: Approval: 

Code Enforcement: Approval: 

Attest: Kimberli Guill, Development Coordinator 

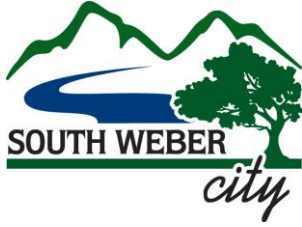

1600 E. South Weber Drive
South Weber, UT 84405

www.southwebercity.com

801-479-3177
FAX 801-479-0066

Violation Notification

****Please note that your Short-Term Rental is in violation of one or more of the below listed conditions regarding your Short-Term Rental Conditional Use Permit. You have been verbally notified of the violation and this is your written warning****

STRIKE 1

Numerous parking related complaints on multiple documented occasions

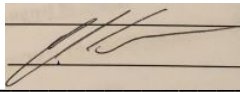
Code Enforcement:  Date: 9/10/2019

Date Mailed: September 26, 2019

Short Term Rental Conditional Use Permit # STR 19-03

Applicant: Cobblestone Resort

Proposed Use: SHORT TERM RENTAL

Address: 1923 E Canyon Drive South Weber UT, 84405

Along with compliance to all applicable state and city code, the conditional use for the above applicant at the property listed and the use proposed has been approved by the **Planning Commission on (August 8, 2019)** with the following conditions:

- 1- Comply with ALL portions of ORD 19-12: Regulations pertaining to Short-Term or Vacation Rentals.
- 2- ALL Tenants MUST use off street Parking
- 3- Maximum of 18 Occupants
- 4- Conditional Use Permit Review Yearly

Note: City Staff shall have the right to inspect and enforce conditions. Any non-compliance will be subject to cancellation of this permit. Any requests for change must be made in writing and approved by the Planning Commission in a public meeting.

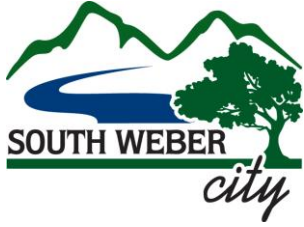

1600 E. South Weber Drive
South Weber, UT 84405

www.southwebercity.com

801-479-3177
FAX 801-479-0066

Violation Notification

****Please note that your Short-Term Rental is in violation of one or more of the below listed conditions regarding your Short-Term Rental Conditional Use Permit. You have been verbally notified of the violation and this is your written warning****

STRIKE 2

Additional parking violations; Noise afterhours; Pool use afterhours

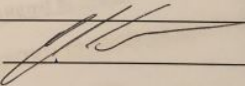
Code Enforcement:  Date: 9/19/2019

Date Mailed: September 26, 2019

Short Term Rental Conditional Use Permit # STR 19-03

Applicant: Cobblestone Resort

Proposed Use: SHORT TERM RENTAL

Address: 1923 E Canyon Drive South Weber UT, 84405

Along with compliance to all applicable state and city code, the conditional use for the above applicant at the property listed and the use proposed has been approved by the **Planning Commission on (August 8, 2019)** with the following conditions:

- 1- Comply with ALL portions of ORD 19-12: Regulations pertaining to Short-Term or Vacation Rentals.
- 2- ALL Tenants MUST use off street Parking
- 3- Maximum of 18 Occupants
- 4- Conditional Use Permit Review Yearly

Note: City Staff shall have the right to inspect and enforce conditions. Any non-compliance will be subject to cancellation of this permit. Any requests for change must be made in writing and approved by the Planning Commission in a public meeting.

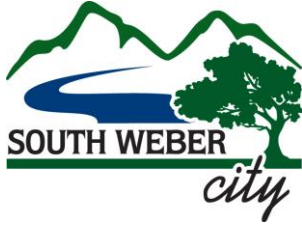

1600 E. South Weber Drive
South Weber, UT 84405

www.southwebercity.com

801-479-3177
FAX 801-479-0066

Violation Notification

****Please note that your Short-Term Rental is in violation of one or more of the below listed conditions regarding your Short-Term Rental Conditional Use Permit. You have been verbally notified of the violation and this is your written warning****

STRIKE 3

Operation of a Sexually Oriented Business

Your Presence is REQUIRED at the Special Planning Commission meeting/public (show-cause) hearing on October 23, 2019 to discuss revocation of your STR Conditional Use Permit.

Code Enforcement:  Date: 10/03/2019

Date Mailed: 10/12/2019

Short Term Rental Conditional Use Permit # STR 19-03

Applicant: Cobblestone Resort

Proposed Use: SHORT TERM RENTAL

Address: 1923 E Canyon Drive South Weber UT, 84405

Along with compliance to all applicable state and city code, the conditional use for the above applicant at the property listed and the use proposed has been approved by the **Planning Commission on (August 8, 2019)** with the following conditions:

- 1- Comply with ALL portions of ORD 19-12: Regulations pertaining to Short-Term or Vacation Rentals.
- 2- ALL Tenants MUST use off street Parking
- 3- Maximum of 18 Occupants
- 4- Conditional Use Permit Review Yearly

Note: City Staff shall have the right to inspect and enforce conditions. Any non-compliance will be subject to cancellation of this permit. Any requests for change must be made in writing and approved by the Planning Commission in a public meeting.

SOUTH WEBER CITY PLANNING COMMISSION MEETING

DATE OF MEETING: 23 October 2019

TIME COMMENCED: 6:00 p.m.

LOCATION: South Weber City Office at 1600 East South Weber Drive, South Weber, UT

PRESENT: COMMISSIONERS:

Tim Grubb
Debi Pitts
Rob Osborne
Wes Johnson
Taylor Walton (excused)

CODE ENFORCER:

Chris Tremea

CITY PLANNER:

Barry Burton

CITY ENGINEER:

Brandon Jones

DEVELOPMENT COORDINATOR:

Kimberli Guill

Transcriber: Minutes transcribed by Michelle Clark

ATTENDEES: Clay Simpson, Corinne Johnson, Bridgette Hadlock, Tom Wright, Hilary Bench, Kathy Devino, Joan Turner, Bill Turner, Blair Halverson, Sandra Layland, Haley Alberts, Paul Sturm, Kathryn Hansen, Chris Hansen, Matt Smith, Chris Pope, Ember Davis, Mike Sampson, Michael Grant, Misti Lopez, Tammy Long, Mindi Smith, Jeff Bench, Jan Ukena, Amy Mitchell, Linda Marvel, Natalie Layland, WonAe Mier & Dustin Shiozaki.

PLEDGE OF ALLEGIANCE: Commissioner Pitts

Commissioner Johnson moved to open the public hearing for action on Short Term Rental Conditional Use Permit Revocation: Cobblestone Resort located at 1923 E Canyon Drive South Weber UT 84405 (Parcel ID# 13-184-0030) 1.14 acres. Commissioner Pitts seconded the motion. Commissioners Grubb, Pitts, Osborne, and Johnson voted aye. The motion carried.

***** **PUBLIC HEARING** *****

Public Hearing (show-cause) and Action on Short Term Rental Conditional Use Permit Revocation: Cobblestone Resort located at 1923 E Canyon Drive South Weber UT 84405 (Parcel ID# 13-184-0030) 1.14 Acres: Tanner Clagett, attorney in Bountiful, explained he was contacted this week by Dustin Shiozaki to represent him. Commissioner Osborne explained recently the City passed an ordinance allowing for short term rentals within the City with the

approval of a conditional use permit. This property owner has received three strikes. Tanner voiced he has received copies of the three strikes and has expressed to Dustin it is within his interest to comply with the city code. He understands this. One of the reasons he hired Tanner is to get in compliance and make sure he is doing what he needs to do. Tanner has spoken to Dustin about Strike #3. He understands Dustin is involved in a boudoir business. He informed him that somewhere along the line the property address came to be on that website. He said that has been removed and there is no operation of a business that falls under a sexually oriented business by the city's definition. He understands there has been off street parking. He said Dustin tries very hard to inform renters of the parking restrictions. Tanner explained Dustin has expressed an interest to comply and work with the City.

Chris Tremea, Code Enforcer, discussed the short-term rental committee who helped draft the short-term rental ordinance which was adopted on 8 August 2019. Prior to August, Chris communicated with Dustin because he received a lot of normal nuisance complaints, even outside of the short-term rental. He reported parking in the street and on the grass has been an issue as well as there were several noise complaints. During this process the upstairs was being used with the downstairs being under construction. The conditional use permit allowed for either upstairs or downstairs being rented but not both. He pointed out there have been times when as many as 50 vehicles are at this short-term rental with vehicles blocking resident's driveways. He said all these complaints have been discussed with Dustin. He said there have been times when the Davis County Sheriff's Department has been contacted. He voiced there have been numerous warnings given and nuisance violations.

Chris explained Strike #2 included parking violations; noise afterhours, and pool use afterhours. He described a time where there were 36 people going in and out over a weekend time frame. He then discussed Strike #3. He said there was an incident in late June or early July in which a blue tarp was put up around the pool. There was someone taking pictures of a topless lady in the pool. This was seen by a resident. Chris did talk to a renter who said a photo shoot was going on. He explained a resident texted him concerning information received on the internet concerning a boudoir business that was being advertised at the short-term rental. He and a deputy reviewed information received, and it was obvious this business was operating as a sexually oriented business.

Chris discussed the events of a couple of weekends ago in which the Davis County Sheriff's Department was involved with and has documentation. Chris said he did not give a Strike #4. He said attempt for compliance has been deceitful, and non-compliant by both the property owner and the business owner. He knows there are a lot of citizens who are extremely concerned for their property. Tanner asked about one floor only being used. Chris said there is only one rental agreement with one party up to 18 people. Commissioner Osborne said the number 18 came from the Planning Commission and discussion with the owner concerning what would be a fair number. He explained the Planning Commission looks at number of square footages, parking, and number of beds to come up with the occupancy number. Tanner commented he hopes that by him being here is evidence that Dustin is trying to address some of these issues. He said Dustin has provided a memo of what his obligations are to be. He did discuss the boudoir photography with Dustin and there is no longer photography going on. Chris explained he asked Dustin specific questions about the photography and he said they were not aware of the photography. He feels there was deceit.

Commissioner Osborne asked if there was any public comment.

Jeff Bench, 1916 East Canyon Drive, wishes no ill-will on anyone, but the situation has not improved. He expressed his frustration after last weekend he had to clean up beer bottle and cans from his yard. He doesn't see that anything will adjust and change. He doesn't see any positive to the City of South Weber, neighbors, or community for this to continue. He encouraged the Planning Commission to revoke the license.

Thomas Wright, 1934 East Canyon Drive, stated there is a lot of documentation over the problems at this property. He expressed this is similar to a cancer invading your life. He pointed out if this was in front of your house you would do everything you could to get rid of it.

Misti Lopez, 1191 East Canyon Drive, explained there are other VRBO's in the City that don't have these issues. She knows they can be run respectfully. She commented just because there is something happening in one, doesn't mean that is happening everywhere. She expressed there are ways to run a business and be successful.

Sandra Layland, 7294 S. 1950 E., understands there are well ran VRBO's in the City. She has attended meetings when they were granted, and she wished they were next to her home verses the existing short-term rental next to her home. She has attended many City Council and Planning Commission meetings. She has proof that Dustin has information on the Air B&B website and VRBO that advertises a lower level apartment. She also has reviews from someone who rented the basement while there was someone else renting the upstairs. She explained how difficult it is for the neighbors who live in this area. She said there is also a new subdivision going in next to this short-term rental. She feels the owners have had enough chances. She said we have reported violations and presented information to the City. She asked for the Planning Commission to revoke the conditional use permit because their pattern of behavior is not to be honored. **(SEE ATTACHED)**

Paul Sturm, 2527 Deer Run Drive, explained when the application for conditional use permit for this short-term rental was being discussed at the Planning Commission meeting on 8 August 2019, there were also other applicants for short term rentals on the same agenda. He feels the Planning Commission treated each one of them fairly.

Commissioner Grubb moved to close the public hearing for action on Short Term Rental Conditional Use Permit Revocation: Cobblestone Resort located at 1923 E Canyon Drive South Weber UT 84405 (Parcel ID# 13-184-0030) 1.14 acres. Commissioner Johnson seconded the motion. Commissioners Grubb, Pitts, Osborne, and Johnson voted aye. The motion carried.

***** **PUBLIC HEARING CLOSED** *****

Sergeant Pope, of Davis County Sheriff's Department, reported the following activity at the Cobblestone Resort:

April 25th unknown guest with argument back and forth with owners and contractors
June 8 lewdness – topless in pool
June 27th vandalism to pool
Sept 23rd victim was burglarized
Sept 25th request for extra patrol
Oct 3 agency assist
Oct 12 multiple police vehicles arrived for underage drinking/ 11 citations were given for illegal consumption/21 offenders/ 10 officers responded

Commissioner Grubb moved to revoke immediately the Short Term Rental Conditional Use Permit for Cobblestone Resort located at 1923 E Canyon Drive South Weber UT 84405 (Parcel ID# 13-184-0030) 1.14 acres based on non-compliance of the conditional use permit issued on 8 August 2019, namely parking, occupancy, multiple unlicensed businesses & contracts, activity not appropriate with a business in a residential neighborhood, and continued lack of effort to comply or conform with the South Weber City ordinances. Commissioner Pitts seconded the motion. Commissioners Grubb, Pitts, Osborne, and Johnson voted aye. The motion carried.

Commissioner Johnson recommended the City staff send a letter to Air B&B stating the conditional use permit has been revoked. Commissioner Grubb stated the property owner can always reapply for another conditional use permit, but if they continue use, it will become a civil matter.

PLANNING COMMISSION ITEMS:

Commissioner Grubb: pointed out last night's meeting was nice. He attended a nice workshop today. Hopefully, Wasatch Front and UDOT listened to what we said.

Commissioner Johnson: thanked the citizens who showed up at last night's meeting.

Commissioner Osborne: discussed how much he appreciates the communities help with this agenda item.

Chris Tremea: appreciates the patience the citizens have had in this process and he thanked them for being able to work with them.

Sergeant Cope: thanked the citizens for not taking it into their own hands. He appreciated the community coming together and their patience.

A joint City Council and Planning Commission meeting will be held on 12 November 2019.

ADJOURNED: Commissioner Grubb moved to adjourn the Planning Commission meeting at 6:58 p.m. Commissioner Pitts seconded the motion. Commissioners Grubb, Pitts, Osborne, and Johnson voted aye. The motion carried.

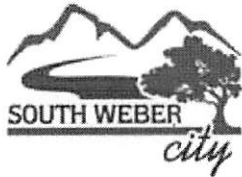

South Weber City

City Council Agenda Application

1600 East South Weber Drive • South Weber, Utah 84405 • Phone: (801) 479-3177 • Fax: (801) 479-0066

City Council meetings are held the second, third and fourth Tuesdays of each month beginning at 6:00 p.m. This application must be submitted by 5:00 p.m. eight (8) days prior to the meeting.

=====
 Name: Brent Poll
 Address: 7605 S. 1375 E.
So. Weber, UT 84405
 Phone: (801) 479-3786
 E-mail: brent_poll@hotmail.com
 =====

Date of City Council Meeting you request to be placed on: ASAP
 =====

PURPOSE/REASON TO BE ON CITY COUNCIL AGENDA:

The plume maps (pollution) and the City's land-use decisions predicated largely upon them, are extremely inaccurate

WHAT IS YOUR RECOMMENDATION?

Correct them to coincide with the Phase III environmental audits and RODs (and Federal environmental laws) which essentially

CITY DEPARTMENT INPUT:

show the entire western part of our City as polluted.

SIGNATURE:  DATE: 11/5/19

This application allows you to be placed on the City Council agenda for items of **discussion** only, no official action will be taken.

South Weber Coalition

Director:
Brent Poll

Technical Adviser
Dr. John Carter



2 November 2019

City Council and Planning Commission
City of South Weber
1600 East South Weber Drive
South Weber, Utah 84405

Subject: General Plan - Sensitive Lands

Dear Council and Planning Commission,

Federal environmental law (CERCLA) establishes, in 42 USC Chapter 103 subchapters 9601 and 9607, that: (1) every owner of property where “a hazardous substance has come to be located” thereby owns a “facility;” and that (2) “owners (both current and former)” and “operators” of such facilities are deemed to be “Potential Responsible Parties (PPPs)” regarding the pollution at issue. CERCLA is particularly harsh towards such owners and operators who profess ignorance of their situations.

This ignorance of affected polluted-property owners in our City has been greatly exacerbated by the diminutive and grossly inaccurate sensitive-land maps (regarding where hazardous substances have ‘come to be located’) within the City’s General Plan. Those affected property owners could well argue that they had cause to rely on their elected and appointed City officials on such a complex and technical matter. All officials swear to promote and safeguard the health and welfare of present and future residents. Moreover, City ordinances authorize our Planning Commissioners to do whatever ‘it takes’ to measure up to the high standards of their official positions.

However, a review of the City’s written and oral records on the subject of HAFB pollution, shows that most of our City officials (present and relatively-recent past) have not even read or otherwise reached a comprehensive appreciation of even the most basic aspects of the Superfund/NPL-level threats relating to our valley. The diminutive plume maps in our General Plan currently and proposed for continuation in our next one, are prime examples of this critical deficiency. Those are collectively many times smaller than defined by the Air Force, EPA and the State of Utah just for the Operable Unit One (OU1) plume as shown on page 1-1 (item 1.0.0.6.) in their 1998 ROD. This plume, much like the one described by the Army Corps of Engineers a decade earlier, showed virtually the entire western portion of our City as where “hazardous substances have come to be located.”

The mystery is: How did our City ever create a General Plan with diminutive plume maps which so radically contradict the relatively huge affected land mass defined by the polluter, EPA and the State of Utah? Did the City conjure those tiny maps from thin air, or did it rely on some source still willing to validate this controversial conclusion? Does the City contend that the remedial plan, enacted through the 1998 ROD, worked as promised to restore our valley to its pre-polluted condition by 2010? However, studies since 2010 show that the remediation promised in 1998 failed. New projections predicted that full remediation was not probable “until some uncertain time in the

2040s.” After the failure of the 1998 ROD, did HAFB/EPA/UDEQ or any other entity solicit (and share with the City) another environmental audit to ascertain whether any significant portion of the polluted area in our City (in accord with the plume described above in 1998 ROD) had, in fact, been restored from the existence and/or continue threat of pollution migrating from HAFB? If so, please share it with everyone. If such a study had been undertaken, we would have likely participated in it as most of the pollution at issue passes first through our properties on its way to pollute others.

While CERCLA faults passive and willful ignorance of owners and operators of facilities, none of them swore and oath to safeguard their present and future neighbors. Each of you should shoulder much of their blame. They had cause to trust you to perform your sworn duties and responsibilities. Your actions and inactions (see recent letter to RAB copied to the City) created hundreds and potentially thousands of more human receptors of the Base’s pollution with all the risks inherent to such exposures. You further helped create, with the developers, hundreds of new PPPs with all the potential legal liabilities this entails. Unfortunately, even if you had the will and inclination to reverse your past legislative recklessness (and you should try), much of the potential damage has already been established through your increases in human density within the polluted areas of our City.

The only thing that our Coalition can do at this stage (after trying unsuccessfully for decades to compel genuine remediation) is to warn those the City has been complicit in endangering both with Superfund/NPL-level pollution and its associated potential legal liability. As PPPs ourselves, our advisers claim that we have an obligation to warn those downgrade about the problems cited above. We have done some of this in the past, but the City’s large and yet anticipated influx of new threatened subdivisions means that we still have much more such work ahead of us.

Include this letter with the documentation being collected in conjunction with preparation/approval of the updated General Plan. Also, consider this as a formal request to discuss this topic (for up to 10 minutes) in future meetings with both the Commission and the Council where the updated General Plan is a primary topic on the agenda. Please let me know if you have questions or observations concerning this letter.

Brent Poll
Executive Director

South Weber Coalition

Director:
Brent Poll

Technical Adviser
Dr. John Carter



22 Oct 2019

Restoration Advisory Board
C/O Barbara Fisher
75th Air Base Wing – Public Affairs
Hill Air Force Base, Utah

Subject: Potential Responsible Parties (PPP)

Dear RAB Members,

My brother was the first, almost 60 years ago, to identify pollution leaking from HAFB into the South Weber valley. Our family and the South Weber Coalition have been working for decades since then to promote proactive remediation of this problem; and to educate the affected public regarding this threat. I first served on the Base's initial Technical Review Committee (TRC), and then for years as a charter member of your Restoration Advisory Board (RAB) which later replaced the TRC. Throughout this and subsequently through reviews of most of your meeting minutes, there seems to have been an avoidance of the subject referenced above. This letter is a request for the RAB to remedy this, and then to hopefully help educate those you represent with the results of your review.

Our attorneys warned us from the outset that we should expect to share responsibility for the pollution migrating through our properties on its way to pollute others within the valley. Federal Environmental laws (CERCLA) in 42 USC Chapter 103, Subchapter 9601 (9) (B) defined all such tainted properties as a 'facility' because "a hazardous substance has come to be located" there. The liability for being thus polluted is defined in 42 USC Chapter 103 Subchapter 9607 (a) (1). 'Owners' and operators' (including current and former ones) of a 'facility,' are deemed to be "Potential Responsible Parties (PPPs)." The 1998 ROD for Operable Unit One (OU1), Page1-1, item 1.0.0.6., shows that the "plume associated with the on-Base Source Area disposal sites has migrated approximately 2200 feet north/northeast of the Base property boundary." This description essentially echoed the conclusions of the Army's Corps of Engineers which mapped the same plume a decade earlier. It found further that this migration ultimately reached the Weber River and virtually the entire western part of the City of South Weber. The Corps findings were shared with the Base, State officials and residents in a well-attended meeting in the City's elementary school. This scope/extent of contamination has not been amended subsequently. Therefore, every current and former 'owner' (since contamination) of a 'facility' within the plume so identified above, is a Potential Responsible Party, as expressly defined in specific Federal statutes.

There is a large amount of reliable readily-available legal requirements, reviews, opinions and case histories relating to potential liabilities for PPPs. One can learn much from simply 'googling' CERCLA then checking sub-categories of Potential Responsible Parties, ignorance, strict liability, joint liability, property transfers, potential-lender liability; etc. A few of many germane indisputable conclusions

such an exercise will produce include: (1) CERCLA “makes passive, willful and other forms of ignorance a liability and rewards informed responsible action.” (2) There is a “duty to disclose (facility) contamination before transfer” if not “such a defendant shall be treated as liable under section 9607 (a) (1) with no defense under Section 9607(b) (3) shall be available to the defendant.” (3) “Did the owner/operator act reasonably to avoid or mitigate harm?” This inquiry is viewed under a “strict liability” standard for all PPPs.

A wealth of PPP-related knowledge can be gained simply, as cited above, but our family felt this was too serious and technical just for self-reliance. We accordingly hired three lawyers over the years to study this issue and to provide advice regarding how we should address the HAFB pollution located upon and still threatening our properties plus others near our own. They advised us mainly concerning: (a) what we could and shouldn't raise/grow on our contaminated properties, (b) that we should proactively push for genuine remediation of the pollution at issue, (c) to do nothing which could compromise or promote the migration of the pollution towards others and (d) to warn those near and downgrade from us that pollution had flowed (and continues to flow) through and under ours to pollute their properties, and (e) to suggest they study all the implications relating to this.

However, a basic concern our attorneys volunteered in addition was their united opinion that we, and other polluted-property landowners, might well be the primary targets regarding any potential successful litigation for damages relating to the Base's migrating pollution. They argued that such litigation against HAFB was protected under the Federal Tort Claims Act (FTCA). This means, under the Doctrine of Sovereign Immunity, that the Federal Government cannot be sued without its express permission. Any claimant would have to establish that 'negligence' was the causal factor for the alleged injury at issue. Ignorance and certainly thoughtlessness were factors for the Base's dumping of its pollution “all along the hillside” above our valley. However, interviews showed that those doing this disposal were generally uninformed regarding the substances being dumped. Moreover, there is not a shred of evidence that anyone disposing of the Base's pollution knew beforehand that their actions would cause the severe risks ultimately found to warrant the Base's Superfund Site/National Priority Listing (NPL) designations. Therefore, a charge of 'negligence' seems inappropriate.

We later learned that 'owners' of 'facilities' were further hurt by Congressional action which provided military polluters (including HAFB) with a 'Discretionary Function Exception (DFE).' This made actual remediation of the Base's pollution a discretionary rather than a mandatory requirement. This exception was upheld when challenged in Federal District Court (see *Waverly View Investors, LLC vs. USA*, Civil # CCB-14-1527, 13 Jan 2015). Feedback from other oversight entities shows no example where a military polluter has exercised its 'discretion' to fully remediate the pollution it has generated. Furthermore, most of them are charged with manipulating statistics and studies to imply promising remedial enhancements although without much measurable substance. A common means for this is to provide diminutive plume maps which can then be readily but inaccurately construed as 'amendments' to ROD-defined-pollution-plume maps.

Local newspapers (still available for review) documented admissions, after Hill AFB was declared a Superfund site, that it too had been “less than candid” when dealing with the public. Part of this was its continued public insistence that the springs on our hillside were absolutely safe for drinking. Documents later acquired through a FOIA request, however, proved that the Base's own sponsored

research showed indisputably that, the spring-water at issue, was “not fit for human or animal consumption.” One of those springs was once the source of culinary water for an elementary school, several homes and countless other men, women and children for over a century. The dates of the FOIA-provided-proof showed that the Base knew of this ‘unfit’ condition throughout its many years of contrary denials.

Because of their Congressionally-allowed Discretionary Function Exception and the widespread inaction and misdirection that it enabled; military polluters can no longer be taken seriously regarding any supposed future efforts to genuinely remediate their pollution. Genuine remediation, if possible at HAFB, which is debatable, is very expensive. The HAFB 1998 ROD for OU1 shows that it would cost almost \$306 million to affect timely and effective remediation of just that one operable unit. However, the Base chose an extremely cheaper remedial alternative which was to restore our valley to its pre-polluted condition by 2010 if it worked as advertised. But it failed. The premise for the cheap remedial choice was faulty. Rather than working diligently to create a better premise without such overwhelming flaws, the Base/EPA/UDEQ mainly doubled down on their failed plan by primarily saying more time (until some uncertain time in the 2040s.) was needed for their failed alternative to finally work its magic. Meanwhile, residents of our City are still at imminent risk from a Superfund/NPL site which was not remediated as promised.

After this failure, the Base/polluter should have sought to acquire the development rights to every potential development in the area described by the OU1 ROD and earlier by the Army Corps of Engineers. Those acquisitions could have been either continuous or conditional with an ending to equate with actual/verifiable remediation of the pollution at issue. However, it failed to so act. What has been done remedial since is seemingly little of real substance. Certainly nothing that will fully remediate this pollution problem in the foreseeable future (or “some uncertain time” projected to be in the 2040s).

How can valley residents cope with such failures and uncertainties? How should City Officials address them? State law and City ordinances mandate that Cities promote and protect the health and general welfare of “present and future residents.” This is their most fundamental land-use responsibility. There is next to nothing it can do to help remediate the Base’s pollution. However, all PPPs (which includes the City of South Weber) share the basic responsibility of conforming to the requirements cited in Federal statutes for protecting the public from hazardous materials which “have come to be located” on their ‘facilities.’

Creating higher human density in the OU1 polluted areas, which were mostly rural when the 1998 ROD was finalized, undoubtedly creates more risk for exposures. Exposures require human receptors. Without them, there is obviously no chance of exposures. The pollution still exists. The various pathways, mainly provided by Mother Nature to potentially expose human receptors, still exist. However, until the City started creating numerous new subdivisions (against our strong objections), the risks were limited to the significant but relative few residents who already lived there at the time of the plumes creation. New and currently proposed/contemplated subdivisions could potentially increase the potential number of new human receptors to roughly 10 to 20 times higher than the amount of potential receptors living in the area in 1998.

As stated above, besides putting themselves and their families at risk as potential human receptors, each new owner (and potentially any lenders financing the acquisitions) assumed a level of legal jeopardy as a Potential Responsible Party (PPP) due to his/her new ownership of a property where hazardous materials “have come to be located.” Since ignorance of any kind is not well tolerated under CERCLA regarding PPPs; how should it be treated when at least comparable ignorance of pertinent facts is displayed in the oral and written records of a City Council and Planning Commission? Those officials, without doubt, have been the primary contributor for the increase in risk posed by the Base’s pollution since the 1998 ROD was finalized. This is not to infer that those individuals are not generally well-intended and otherwise sometimes commendable for their public service. However, there is no conceivable excuse for them directly causing so much greater NPL-level risks for our present and future population, rather than striving to protect everyone from such risks.

Much like our military polluter, City officials also enjoy protections that might save them from legal jeopardy. Although they’ve made gross errors in preparations/judgments/decision-making which adversely affect the populations they have sworn to serve, they seem now to possibly be less at risk than all the hundreds of new PPPs they have placed in jeopardy because of their lack of proper preparation relating to the pollution matters at issue.

In summary, the status quo is a mess. The City and the polluter (with EPA and UDEQ participation) caused a huge problem. Rather than fewer potential human receptors of the Base’s pollution and fewer PPPs facing legal jeopardy from the pollution on their properties, we now have more of both with many more still on the way. Failure has consequences. HAFB/EPA/UDEQ failed to produce the results (e.g.; resolution by about 2010) promised in their 1998 ROD. The Base’s pollution sources still leak and all three concur that (even if their plans eventually work), full remediation is still decades away. Nevertheless, the City wrongly moved ahead as if the pollution issue was actually resolved. Both wrongdoers seem protected from most negative factors stemming from their misjudgments by various laws/regulations. Who serves those the wrongdoers needlessly placed at continued risk?

Protection, especially for the most vulnerable (old folks, pregnant women, young children), is a matter that hopefully the RAB can address. Moreover, while ignorance is frowned upon by CERCLA, it seems that the hundreds of new lot owners/PPP’s are small fish compared to the City and the Base. Those bigger fish showed far worse judgment than the smaller fish. The largest mistake the smaller fish made seems to have been in giving undue credence to the misjudgments of the bigger fish. Hopefully, the RAB can address this imbalance too. Please let me know if you have questions.

Sincerely,
Brent Poll
Executive Director



New Administrative Record

- **Transitioning to web based repository**
 - <http://afcec.publicadmin-record.us.af.mil/>
 - **Contains documents through early 2011**
 - **Working on uploading documents since 2011**
 - **Priority 1 – Decision Documents**
 - **Priority 2 – Documents after July, 2014**
 - **Priority 3 – Documents between 2011 and July, 2014**



Login Screen

The screenshot shows a web browser window with the URL <http://afcec.publicadmin-record.us.af.mil/>. The page title is "AF Administrative Record". The header includes the "U.S. Air Force Civil Engineer Center" logo and the "U.S. AIR FORCE" logo. The main content area is blue and contains the following text:

AF Administrative Record Version: 1.0.3

The AFCEC CERCLA Administrative Record Search website provides a means to search and review public documents regarding environmental testing and sampling conducted at Air Force installations in compliance with the federal Comprehensive Environmental Response, Compensation, and Liability Act (CERCLA). These documents form the basis for environmental response actions and demonstrate the public's opportunity to participate in and comment on the selection of the response action. AFCEC continuously updates the Administrative record for each installation until the remedy selection documentation is complete.

AFCEC provides integrated engineering and environmental management, execution, and technical services that optimize Air Force and Joint capabilities through sustainable installations. AFCEC is the DoD leader in worldwide engineering and environmental services – enabling sustainable Air Force and Joint installations to project global air, space, and cyber power.

For consistency and ease of access, documents are stored and presented in standard PDF format. A PDF viewer is required to view the documents. Adobe Reader is available as a free download from Adobe software.

[Continue to site](#)

The Official Web Site of the Air Force Administrative Record USA.gov Accessibility/Section 508



Finding Documents, cont.

AF Administrative Record Version: 1.0.3 [?](#) Help

Active Duty
 Air National Guard
 BRAC

Installation List

- Fort Eustis, VA
- Fort Richardson, AK
- Fort Sam Houston, TX
- Fort Yukon AFS, AK
- Galena AFS, AK
- Goldwater AFR, AZ
- Goodfellow AFB, TX
- Grand Forks AFB, ND
- Granite Mountain RRS, AK
- Grisson ARB, IN
- Gulfport AFRH, MS
- Hanscom AFB, MA
- Hill AFB, UT**
- Holloman AFB, NM
- Homestead ARB, FL
- Hurlburt Field AFB, FL
- Indian Mountain LRRS, AK
- Johnston Atoll BR, HI
- Kaala AFS, HI
- Kaena Point STS, HI
- Kalakaket Creek RRS, AK
- Keesler AFB, MS
- King Salmon AFS, AK
- Kingsley Field AFB, OR
- Kirtland AFB, NM

Hill AFB, UT

Subject or Title:

Full Metadata Search:

Full Document Search:

Author: Author Affil:

Recipient: Recipient Affil:

Sites

- AOC N-051 UTTR Area of Concern
- AOC N-052 UTTR Area of Concern (N
- AOC XS-208 UTTR Area of Concern (
- AST A00036.1 AST A00036.1
- AST A00519.0 AST A00519.0
- AST A00570.1 AST A00570.1
- AST A00758.1 AST A00758.1
- AST A00783.0 AST A00783.0
- AST A00925.1 AST A00925.1
- AST A01214.1 AST A01214.1

OUs

- OU 1 LF001
- OU 1 LF001
- OU 3 ST004, WP005
- OU 5 SS017, SS091
- OU 6 ST022, OT026
- OU A Little Mountain
- OU NR-1 WP025
- OU1 FT009
- OU10 SS109
- OU11 OT097

RODs

- ROD_1061 Final Record of Decision
- ROD_1119 Record of Decision Oper
- ROD_1231 Record of Decision for O
- ROD_129 U.S. Air Force Installation
- ROD_1297 Record of Decision for an
- ROD_1348 Final Record of Decision
- ROD_1393 Decision Document for IF
- ROD_1412 Building 786 No Further I
- ROD_1432 Pond 7 Area No Further I
- ROD_1739 Decision Document for IF

Documents After: Documents Before:

Records returned: 6

KBs	View	Subject or Title	Author / Author Affiliation	Document Date	AR #
4,410		FINAL Record of Decision for Operable Unit 12	MWH	09/23/2008	2761
96		Basewide Sampling and UST Monitoring and Maintenance, Cost Reimbursable Request # 1 - UST Site 914 2009 Groundwater Elevation and Free Product Monitoring	Anne Parry / CH2M HILL	04/08/2008	3293
2,885		FINAL Remedial Action Report for Post-ROD Activities at Operable Unit 5	MWH	09/30/2007	2554
3,347		Final Record of Decision for Operable Unit 5	MWH Americas, Inc.	07/01/2006	1061
4,642		Final Record of Decision for Operable Unit 8	Environmental Management Directorate, Hill Air Force Base	03/01/2005	1348
1,674		FINAL Record of Decision for Operable Unit 3		09/30/1995	692



Finding Documents, cont.

- **Select “Hill AFB, UT” in the Installation List**
- **Click “Search” to see a list of all documents for Hill AFB**
- **Type key words in “Full Metadata Search” or “Full Document Search”, then click “Search” to find specific documents**
- **Click on the magnifying glass next to the document to open and view**